

DURAVANE II

Submittal

JDV3 10LI / JDV4 10LI
DuraVane II Architectural
Copper/Aluminum and
Steel Elements

Specification

JDV3 Slip Jointed Enclosure

ENCLOSURE:

STYLE: DuraVane Front Louvered Inlet
OUTLET: Extruded Aluminum
Pencil Proof

LENGTHS: 2' thru 8' in 6" Increments
MAT'L: 16 Ga. CRS STD.

14 Ga. CRS (Opt'l)
FINISH Baked Enamel Std.
 16 Ga. Stainless Steel (Opt'l)
 14 Ga. Stainless Steel (Opt'l)
 14 Ga. Aluminum (Opt'l)
 12 Ga. Aluminum (Opt'l)

FLOOR ANGLE:

Ext. Al (Clear Anodized)
 1" x 1" CRS B.E. finish (Opt'l)

ACCESSORIES:

JDV Overlapping Type

JDV4 Slip Jointed Enclosure

BACKPLATE:

TYPE: Partial B/P
LENGTHS: 8' Only
MAT'L: 20 Ga. Prepainted Std.
 18 Ga. Galvannealed (Opt'l)
 Full Ht. B/P (Opt'l)
2' thru 8' in 6" increments
 20 Ga. Galvannealed (Opt'l)
 18 Ga. Painted (Opt'l)

AIRSEAL:

1/8" x 3/8" Closed Cell (Opt'l)

BRACKETS:

B.B. Hgr. Wall Mtd. 3
 B.B. Hgr. Wall Mtd. 4

JDV3 10LI

ELEMENT TUBE SIZE	CRADLE NO.	A
3/4 COPPER	2	5 13/16
1" COPPER	2	6"
1 1/4 COPPER	1	5 7/16
1 1/4 STEEL	1	5 5/8

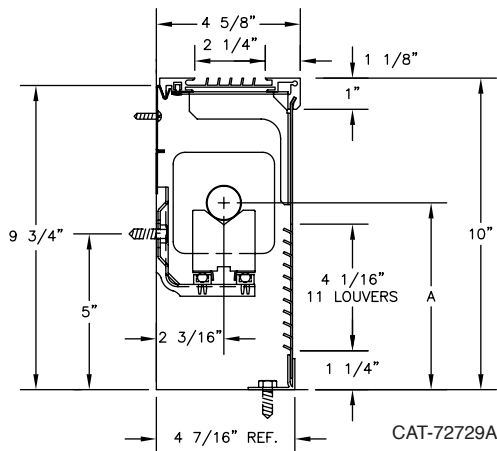

JDV4 10LI

ELEMENT TUBE SIZE	CRADLE NO.	A MAX.
3/4 COPPER	2	5 13/16
1" COPPER	2	6
1 1/4 COPPER	2	6 1/8
1 1/4 STEEL	2	6 5/16
2" STEEL	1	6 1/16

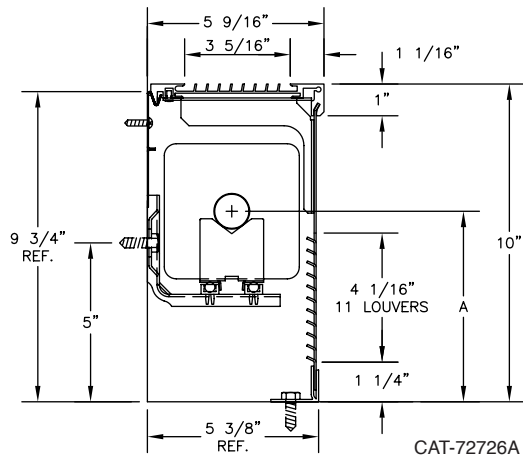

260 North Elm St., Westfield, MA 01085
(413) 568-9571 Fax: (413) 564-5661
www.vulcanrad.com



11/2018

PROJECT: _____ DATE: _____

LOCATION: _____

ARCHITECT: _____

ENGINEER: _____

CONTRACTOR: _____

PO NUMBER: _____

STYLES JDV3 & JDV4 10LI DURAVANE II LOUVERED INLET

COPPER/ALUMINUM ELEMENT					ENCLOSURE DEPTH IN INCHES	ENCLOSURE HEIGHT IN INCHES	TIERS AND CENTERS IN INCHES	MTG. HEIGHT IN INCHES	STEAM 215° FACTOR	Hot Water (AVG.)						
TUBE SIZE	CATALOG DESIGNATION	FIN SIZE IN INCHES	FIN/FT	FIN THICKNESS						1.00	200°	190°	180°	170°	160°	150°
											Factor					
3/4"	VC3/4-34	3-1/4" SQ.	40	0.020"	4-5/8	10	1	10	950	820	740	655	580	510	430	
3/4"	VC3/4-35	3-1/4" SQ.	50	0.020"	4-5/8	"	"	"	960	830	750	670	590	510	430	
1"	VC33	3-1/4" SQ.	32	0.020"	4-5/8	"	"	"	800	690	620	550	490	430	360	
1"	VC34	3-1/4" SQ.	40	0.020"	4-5/8	"	"	"	920	790	720	640	560	490	420	
1"	VC35	3-1/4" SQ.	50	0.020"	4-5/8	"	"	"	930	800	720	650	570	500	420	
1-1/4"	VC133	3-1/4" SQ.	32	0.020"	4-5/8	"	"	"	770	670	600	530	470	410	340	
1-1/4"	VC134	3-1/4" SQ.	40	0.020"	4-5/8	"	"	"	880	760	700	610	540	470	400	
1-1/4"	VC135	3-1/4" SQ.	50	0.020"	4-5/8	"	"	"	890	770	710	620	540	480	400	
3/4"	VC3/4-434	4-1/4 x 3-5/8	40	0.020"	5-9/16	"	"	"	1180	1020	920	820	720	630	530	
3/4"	VC3/4-435	4-1/4 x 3-5/8	50	0.020"	5-9/16	"	"	"	1255	1090	980	870	770	670	560	
1"	VC433	4-1/4 x 3-5/8	32	0.020"	5-9/16	"	"	"	1090	940	860	750	670	580	500	
1"	VC434	4-1/4 x 3-5/8	40	0.020"	5-9/16	"	"	"	1200	1030	930	830	730	640	540	
1"	VC435	4-1/4 x 3-5/8	50	0.020"	5-9/16	"	"	"	1290	1120	1010	900	790	690	580	
1-1/4"	VC1433	4-1/4 x 3-5/8	32	0.020"	5-9/16	"	"	"	1070	920	830	730	650	560	480	
1-1/4"	VC1434	4-1/4 x 3-5/8	40	0.020"	5-9/16	"	"	"	1180	1020	920	820	720	630	530	
1-1/4"	VC1435	4-1/4 x 3-5/8	50	0.020"	5-9/16	"	"	"	1270	1090	990	880	770	670	570	
1"	VC43	4-1/4" SQ.	32	0.020"	5-9/16	"	"	"	1200	1030	930	830	730	640	540	
1"	VC44	4-1/4" SQ.	40	0.020"	5-9/16	"	"	"	1320	1140	1030	910	810	710	600	
1"	VC45	4-1/4" SQ.	50	0.020"	5-9/16	"	"	"	1340	1150	1050	920	820	720	600	
1-1/4"	VC143	4-1/4" SQ.	32	0.020"	5-9/16	"	"	"	1170	1010	910	810	710	620	530	
1-1/4"	VC144	4-1/4" SQ.	40	0.020"	5-9/16	"	"	"	1300	1120	1020	900	800	700	590	
1-1/4"	VC145	4-1/4" SQ.	50	0.020"	5-9/16	"	"	"	1320	1030	1030	920	810	710	600	

STYLES JDV3 & JDV4 10LI DURAVANE II LOUVERED INLET

STEEL ELEMENT					ENCLOSURE DEPTH IN INCHES	ENCLOSURE HEIGHT IN INCHES	TIERS AND CENTERS IN INCHES	MTG. HEIGHT IN INCHES	STEAM 215° FACTOR	Hot Water (AVG.)						
I.P.S. SIZE	CATALOG DESIGNATION	FIN SIZE IN INCHES	FIN/FT	FIN THICKNESS						1.00	200°	190°	180°	170°	160°	150°
											Factor					
1-1/4"	†VS133	3-1/4" SQ.	32	0.032"	4-5/8	10	1	10	730	630	570	510	450	390	330	
1-1/4"	†VS134	3-1/4" SQ.	40	0.032"	4-5/8	"	"	"	825	720	650	570	510	440	370	
1-1/4"	†VS143	4-1/4" SQ.	32	0.032"	5-9/16	"	"	"	1035	900	810	720	630	550	470	
1-1/4"	†VS144	4-1/4" SQ.	40	0.032"	5-9/16	"	"	"	1150	990	900	790	710	610	520	
2"	†VS242	4-1/4" SQ.	25	0.032"	5-9/16	"	"	"	905	780	710	630	550	480	410	
2"	†VS243	4-1/4" SQ.	32	0.032"	5-9/16	"	"	"	1075	840	840	740	660	570	490	

†NPT threads furnished on steel elements. Please use domestic fittings for proper installation.