

LINOVECTOR II

LV2-S8 11 14
Copper/Aluminum and
Steel Element Ratings

Submittal

Specification

LV2 Slip Jointed Enclosure

ENCLOSURE:

STYLE: Slope Top, Slope Outlet
OUTLET: Stamped Louvers
Pencil Proof

LENGTHS: 2'0" thru 8'0" in 6" Increments

MAT'L: 18 Ga. CRS (Std)
 16 Ga. CRS (Opt'l)
 14 Ga. CRS (Opt'l)
 18 Ga. Stainless Steel (Opt'l)
 16 Ga. Stainless Steel (Opt'l)
 14 Ga. Stainless Steel (Opt'l)
 16 Ga. Aluminum (Opt'l)
 14 Ga. Aluminum (Opt'l)
 12 Ga. Aluminum (Opt'l)

HEIGHT: 8"
 11"
 14"

FINISH: Baked Powder (Std)
 Baked Metallic (Opt'l)

ELEMENT:

TYPE: Cu/AL (Mechanically Expanded)
LENGTHS: 2'0" thru 12'6" in 1" Increments for 1" & 1-1/4" Cu.
2'0" thru 8'0" in 1" Increments for 3/4" Cu.

One End Flared (Std)

TYPE: IPS Steel (Mechanically Expanded)
LENGTHS: 2'0" thru 12'6" in 1" Increments
 NPT Thread both Ends (Std)
 Beveled Ends for Field Weld

See Catalog for Working Pressures

BACKPLATE:

TYPE: Partial B/P
LENGTHS: 8'0" Only
MAT'L: 20 Ga. Prepainted (Std)
 18 Ga. Galvannealed (Opt'l)

TYPE: Full Ht. B/P (Opt'l)
LENGTHS: 2'0" thru 8'0" in 6" Increments
MAT'L: 20 Ga. Galvannealed (Opt'l)
 20 Ga. Painted (Opt'l)
 18 Ga. Painted (Opt'l)

AIRSEAL:

1/8" x 3/8" Closed Cell (Opt'l)

BRACKETS:

Water Brkt w/B.B.
 Wall Mtd Hngr for 2nd Tier

DAMPER:

Damper Blades Factory Installed
 Knob Damper (Opt'l)
 Tamper Resistant (Opt'l)

ACCESSORIES:

LV Overlapping Type

All accessories return to the wall at the bottom and have pre-punched holes for fastening to the wall.

LV2-S8

ELEMENT TUBE SIZE	FIN SIZE HEIGHT x WIDTH	CRADLE NUMBER	A
* 3/4 COPPER	2 1/2 x 2 1/4	1	4 5/16
* 3/4 COPPER	2 1/2 x 2 3/4	1	5"
* 3/4 COPPER	3 3/4 x 2 3/4	2	4 1/2
* 1" COPPER	2 1/2 x 2 3/4	1	5 3/16
* 1" COPPER	3 3/4 x 2 3/4	2	5 5/16
* 1 1/4 COPPER	3 3/4 x 2 3/4	2	5 5/16
* 1" STEEL	3 3/4 x 2 3/4	2	5 15/16

* Damper available with these elements only.

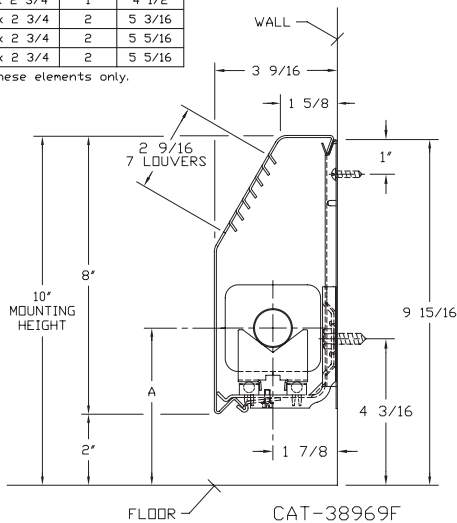

LV2-S11 14

ELEMENT TUBE SIZE	FIN SIZE HEIGHT x WIDTH	CRADLE NUMBER	A
* 3/4 COPPER	2 1/2 x 2 1/4	1	4 5/16
* 3/4 COPPER	2 1/2 x 2 3/4	1	5"
* 3/4 COPPER	3 3/4 x 2 3/4	2	4 1/2
* 1" COPPER	2 1/2 x 2 3/4	1	5 3/16
* 1" COPPER	3 3/4 x 2 3/4	2	5 5/16
* 1" COPPER	5" x 2 3/4	3A	5 1/2
1 1/4 COPPER	3 3/4 x 2 3/4	2	5 5/16
1 1/4 COPPER	5" x 2 3/4	3A	5 11/16
1" STEEL	3 3/4 x 2 3/4	2	5 5/16
1" STEEL	5" x 2 3/4	3A	5 11/16
1 1/4 STEEL	3 3/4 x 2 3/4	2	5 1/2
1 1/4 STEEL	5" x 2 3/4	3A	5 15/16

* 2 tier with damper available in 14" height with these elements only.

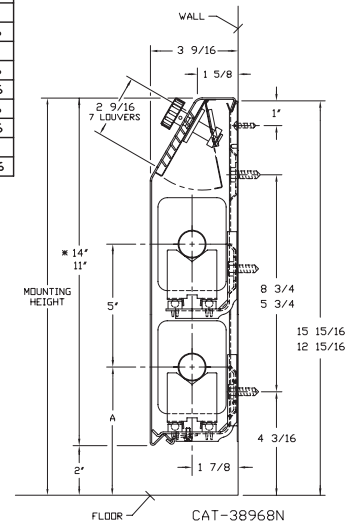

Not recommended for steam applications, consult factory.

Vulcan

RADIATOR

260 North Elm St., Westfield, MA 01085
(413) 568-9571 Fax: (413) 564-5661
www.vulcanrad.com

PROJECT: _____ DATE: _____
LOCATION: _____
ARCHITECT: _____
ENGINEER: _____
CONTRACTOR: _____
PO NUMBER: _____

STYLE "LV2-S8 11 14" LINOVECTOR II

COPPER/ALUMINUM ELEMENTS

ALL RATINGS ARE IN BTU/HR/LIN FT AND BASED ON 3 FPS VELOCITY, 65° EAT

TUBE SIZE	CATALOG DESIGNATION	FIN SIZE HEIGHT X WIDTH	FINS PER FT.	FIN THICKNESS IN INCHES	ENCL HEIGHT IN INCHES	TIERS AND CENTERS IN INCHES	MOUNTING HEIGHT IN INCHES	STEAM 215° FACTOR	HOT WATER (AVG.)								
									200°	190°	180°	170°	160°	150°	140°	130°	120°
									CORRECTION FACTORS FOR AVERAGE WATER TEMPERATURES								
3/4"	VR01	2-1/2" x 2-1/4"	50	.011	8*	1	10	820	710	640	570	500	430	370	330	270	210
					11	1	13	890	770	690	610	540	470	400	360	290	230
					14	1	16	960	830	750	660	590	510	430	380	320	250
					14*	2-5 CL	16	1300	1120	1010	900	790	690	590	520	430	340
3/4"	VR02	2-1/2" x 2-3/4"	60	.010	8*	1	10	950	820	740	660	580	500	430	380	310	250
					11	1	13	1080	930	840	750	660	570	490	430	360	280
					14	1	16	1150	990	900	790	700	610	520	460	380	300
					14*	2-5 CL	16	1650	1420	1290	1140	1010	870	740	660	540	430
1"	VR03	2-1/2" x 2-3/4"	55	.011	8*	1	10	980	840	760	680	600	520	440	390	320	250
					11	1	13	1050	900	820	720	640	560	470	420	350	270
					14	1	16	1180	1010	920	810	720	630	530	470	390	310
					14*	2-5 CL	16	1660	1430	1290	1150	1010	880	750	660	550	430
3/4"	VR04	3-3/4" x 2-3/4"	50	.014	8*	1	10	1010	870	790	700	620	540	450	400	330	260
					11	1	13	1110	950	870	770	680	590	500	440	370	290
					14	1	16	1200	1030	940	830	730	640	540	480	400	310
					14*	2-5 CL	16	1680	1440	1310	1160	1020	890	760	670	550	440
1"	VR05	3-3/4" x 2-3/4"	50	.011	8*	1	10	1020	880	800	700	620	540	460	410	340	270
					11	1	13	1120	960	870	770	680	590	500	450	370	290
					14	1	16	1220	1050	950	840	740	650	550	490	400	320
					14*	2-5 CL	16	1670	1440	1300	1150	1020	890	750	670	550	430
1-1/4"	VR08	3-3/4" x 2-3/4"	50	.020	8*	1	10	1040	890	810	720	630	550	470	420	340	270
					11	1	13	1140	980	890	790	700	600	510	460	380	300
					14	1	16	1200	1030	940	830	730	640	540	480	400	310
					14*	2-5 CL	16	1600	1380	1250	1100	980	850	720	640	530	420
1"	VR07	5" x 2-3/4"	50	.020	11	1	13	1220	1050	950	840	740	650	550	490	400	320
					14	1	16	1290	1110	1010	890	790	680	580	520	430	340
1-1/4"	VR10	5" x 2-3/4"	50	.020	11	1	13	1190	1020	930	820	730	630	540	480	390	310
					14	1	16	1260	1080	980	870	770	670	570	500	420	330

*Not recommended for steam applications, consult factory.

Note: Copper tube furnished flared one end standard.

STEEL ELEMENTS

ALL RATINGS ARE IN BTU/HR/LIN FT AND BASED ON 3 FPS VELOCITY, 65° EAT

TUBE SIZE	CATALOG DESIGNATION	FIN SIZE HEIGHT X WIDTH	FINS PER FT.	FIN THICKNESS IN INCHES	ENCL HEIGHT IN INCHES	TIERS AND CENTERS IN INCHES	MOUNTING HEIGHT IN INCHES	STEAM 215° FACTOR	HOT WATER (AVG.)								
									200°	190°	180°	170°	160°	150°	140°	130°	120°
									CORRECTION FACTORS FOR AVERAGE WATER TEMPERATURES								
1"	VR11	3-3/4" x 2-3/4"	40	.024	8*	1	10	920	790	720	630	560	490	410	370	300	240
					11	1	13	1020	880	800	700	620	540	460	410	340	270
					14	1	16	1100	950	860	760	670	580	500	440	360	290
					14*	2-5 CL	16	1520	1310	1190	1050	930	810	680	610	500	400
1"	VR15	5" x 2-3/4"	50	.024	11	1	13	1170	1010	910	810	710	620	530	470	390	300
					14	1	16	1170	1010	910	810	710	620	530	470	390	300
1-1/4"	VR16	5" x 2-3/4"	50	.024	11	1	13	1190	1020	930	820	730	630	540	480	390	310
					14	1	16	1190	1020	930	820	730	630	540	480	390	310

*Not recommended for steam applications, consult factory.

Notes: 1) Steel fin furnished as .024 thick, painted black.

2) NPT threads furnished on steel elements. Please use domestic fittings for proper installation.

3) The ends can be provided chamfered for field welded fittings when specified.

Design Data

Correction Factor Chart for Non-Standard Mounting Heights

MOUNTING HEIGHT (Inches)	ENCLOSURE STYLE						
	BARE FIN ALL SIZES	FRONT OUTLET	FT (FRONT & TOP)		SLOPE		
			3 1/4" FINS	4 1/4" FINS	2 3/4" FINS	3 1/4" FINS	4 1/4" FINS
40 or more	1.000	1.000	1.000	1.000	1.000	1.000	1.000
38	1.000	1.000	1.000	1.000	1.000	1.000	1.003
36	1.000	1.004	1.005	1.005	1.006	1.007	1.009
34	1.010	1.014	1.011	1.010	1.012	1.013	1.016
32	1.020	1.024	1.017	1.015	1.019	1.020	1.025
30	1.030	1.039	1.029	1.024	1.031	1.033	1.039
29	1.040	1.049	1.035	1.029	1.038	1.040	1.045
28	1.050	1.059	1.041	1.034	1.045	1.047	1.052
27	1.060	1.069	1.046	1.039	1.051	1.053	1.059
26	1.070	1.079	1.052	1.044	1.058	1.060	1.065
25	1.080	1.089	1.058	1.049	1.065	1.067	1.072
24	1.090	1.099	1.064	1.054	1.071	1.073	1.079
23	1.100	1.109	1.070	1.059	1.078	1.080	1.085
22	1.110	1.119	1.076	1.064	1.085	1.087	1.092
21	1.120	1.129	1.082	1.069	1.091	1.093	1.099
20	1.130	1.139	1.088	1.074	1.098	1.100	1.100
19	1.140	1.149	1.089	1.075	1.100	1.100	1.100
18 or less	1.150	1.150	1.089	1.075	1.100	1.100	1.100

TOP OUTLET "T" IS NOT AFFECTED.

The AHRI Ratings cataloged include the factor shown for the recommended mounting height.

If the unit is to be installed at a different height than that recommended, the AHRI Rating (except for Top Outlet) must be adjusted as follows: AHRI Rating multiplied by

$$\frac{\text{Factor from Table Above for actual mounting height}}{\text{Factor from Table Above for recommended mounting height}}$$

FORMULA:

$$\text{Catalog Rating} \times \frac{\text{Factor at 30" Height}}{\text{Factor at 18" Height}}$$

$$\text{SOLUTION: } 1950 \times \frac{1.039}{1.150} = 1760 \text{ BTU/Hr.}$$

DYNAMIC FORMULAS

$$\text{BTU} = \text{GPM} \times 500 \times \text{TD}$$

$$\text{GPM} = \left(\frac{\text{BTU}}{500} \right) \div \text{TD}$$

$$\text{TD} = \left(\frac{\text{BTU}}{500} \right) \div \text{GPM}$$

Design Data

COMMERCIAL FINNED TUBE RATING CORRECTION CHARTS

CATALOG FINNED TUBE RATINGS ARE BASED UPON THE FOLLOWING CONDITIONS:

- 215°F AVERAGE WATER OR STEAM TEMPERATURE
- 65°F ENTERING AIR TEMPERATURE
- 3 FEET PER SECOND WATER FLOW RATE
- CATALOG MOUNTING HEIGHT

USE THE FOLLOWING CALCULATION WITH CORRECTION FACTORS FOR JOB CONDITIONS TO DETERMINE CORRECTED RATING:

$$\text{CORRECTED RATING} = (\text{215°F CATALOG RATING}) \times \left(\frac{\text{CORRECTION FACTOR FOR STEAM OR WATER AND AVERAGE AIR TEMP.}}{\text{CORRECTION FACTOR FOR MOUNTING HTG.-SEE CATALOG RATING}} \right) \times \left(\frac{\text{CORRECTION FACTOR FOR FLOW RATE}}{\text{CORRECTION FACTOR FOR MOUNTING HTG.-SEE CATALOG RATING}} \right)$$

USE THE FOLLOWING CHARTS TO SELECT CORRECTION FACTORS

CHART/WATER VEL./CORR. FACTOR / PRESS. DROP/TOTAL BTU.

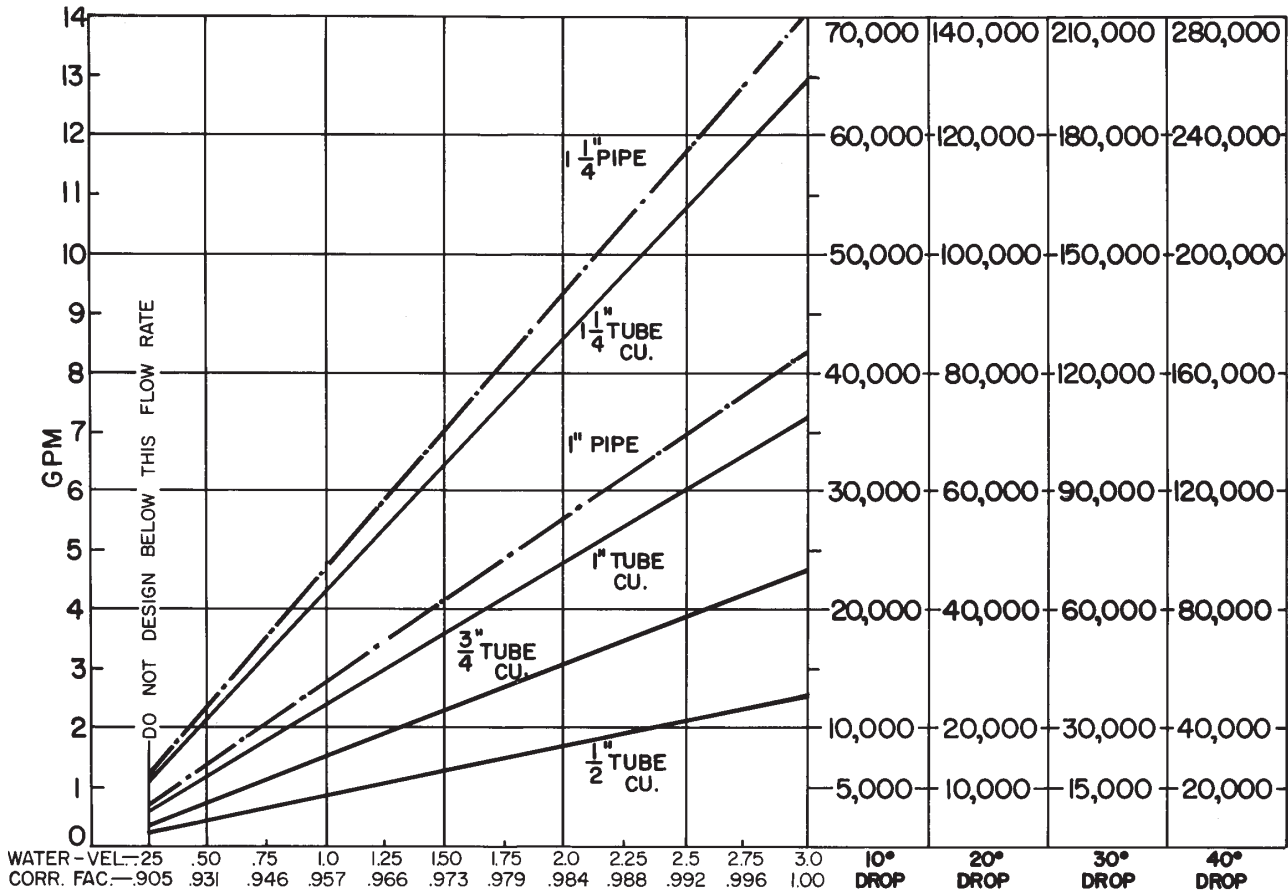

1/2" COP. ALUM.	.180	.233	.333	.533	.916											
3/4" COP. ALUM.	.5	1.5	3.16	5.4	6.25											
1" COP. ALUM.	.233	.41	.83	1.45	2.16	2.83	3.66									
1" PIPE	.37	.79	1.3	2.00	2.70	3.70	4.80									
1 1/4" COP. ALUM.	.16	.33	.55	.79	1.08	1.33	1.8	2.25	2.26	2.91	3.3					
1 1/4" PIPE	.09	.18	.31	.5	.70	1.0	1.1	1.3	1.6	1.8	2.58	2.3	3.3			

PRESSURE DROP PER 100 LINEAR FT., IN FEET OF HEAD

Design Data

INLET AIR CORRECTION FACTOR

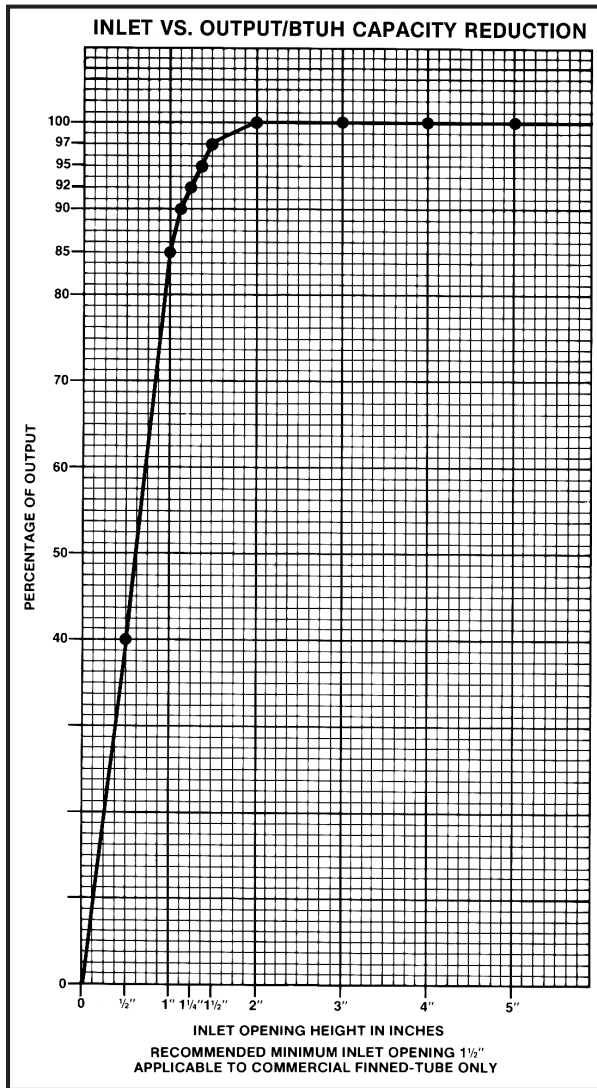

GUARANTEED WORKING PRESSURES

- 1" IPS — 780 AT TEMPERATURES UP TO 650°F.
 - 1 1/4" IPS — 660 AT TEMPERATURES UP TO 650°F.
 - 2" IPS — 405 AT TEMPERATURES UP TO 650°F.
 - 1 1/4" CU — 194 AT TEMPERATURES UP TO 300°F.
 - 1" CU — 204 AT TEMPERATURES UP TO 300°F.
 - 3/4" CU — 218 PSI AT TEMPERATURES UP TO 300°F.
- MAXIMUM PRESSURES AT OTHER TEMPERATURES ARE AVAILABLE UPON REQUEST.

RATE OF PITCH FOR STEAM 1/2" DROP OVER 20 FT. RUN.

PIPE WATER CAPACITIES AND QUANTITIES CIRCULATED AT VELOCITY OF 3* FEET PER SECOND			
Pipe Size	Gals. Per Linear Ft.	Gals./Min. @ 3' Sec. Vel.*	Lbs./Hr. @ 3' Sec. Vel.*
1/2"	.016	2.88	1440
3/4"	.023	4.14	2070
1"	.040	7.20	3600
1 1/4"	.063	11.34	5660
1 1/2"	.102	18.36	9160
2"	.170	30.60	15300
2 1/2"	.275	49.50	24850
3"	.390	70.20	35000

*3 Ft./Sec. Velocity is Basic for Hot Water Rating Factors Shown on this Page.

$$\text{VELOCITY FT./SEC.} = \frac{\text{LBS. PER HOUR}}{(\text{GALS. PER FT.}) (3600) (8.3)}$$

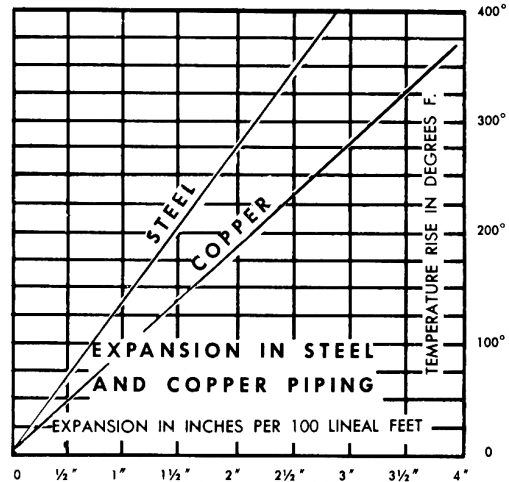

GLYCOL CORRECTION FACTORS

Fluid Temperature 200°F

% Solution	Ethylene Glycol	Propylene Glycol
20	.952	.988
30	.921	.968
40	.888	.943
50	.852	.912

Fluid Temperature 180°F

% Solution	Ethylene Glycol	Propylene Glycol
20	.946	.982
30	.913	.961
40	.879	.934
50	.842	.902

Fluid Temperature 140°F

% Solution	Ethylene Glycol	Propylene Glycol
20	.934	.97
30	.898	.946
40	.861	.916
50	.821	.881

ALTITUDE FACTORS

Approximate factors for convective heat value at varying altitudes

Altitude	Ferrous Units	Copper Alum. Units
Sea Level	1.000	1.000
1,000 ft.	.984	.969
2,000 ft.	.968	.938
3,000 ft.	.952	.908
4,000 ft.	.936	.878
5,000 ft.	.920	.850
6,000 ft.	.904	.822
7,000 ft.	.889	.795
8,000 ft.	.874	.768
9,000 ft.	.859	.743
10,000 ft.	.844	.718
15,000 ft.	.771	.603
20,000 ft.	.703	.502

Design Data

CORRECTION FACTORS FOR STEAM PRESSURES AND AIR TEMPERATURES OTHER THAN STANDARD

STEAM		ENTERING AIR TEMPERATURE, °F														
Pressure		Temp.			STD											
Gauge	Abs. Psi	°F	45	55	65	70	75	80	85	90	100	110	120	130	140	150
(Vac) 15" Hg	7.32	178.9	0.90	0.80	0.70	0.65	0.60	0.56	0.51	0.45	0.39	0.32	0.25	0.18	0.13	0.08
(Vac) 10"	9.78	192.2	1.02	0.91	0.81	0.76	0.71	0.66	0.62	0.55	0.48	0.40	0.33	0.26	0.20	0.14
(Vac) 5"	12.25	202.9	1.11	1.00	0.90	0.85	0.79	0.75	0.70	0.63	0.56	0.48	0.40	0.33	0.27	0.20
(Vac) 0 Psi	14.696	212.0	1.19	1.09	0.97	0.92	0.87	0.82	0.77	0.70	0.63	0.54	0.46	0.38	0.31	0.25
▶ .899	15.595	215.0	1.22	1.11	1.00	0.95	0.90	0.84	0.80	0.75	0.65	0.57	0.48	0.40	0.33	0.26
5	19.70	227.1	1.34	1.22	1.11	1.05	1.00	0.95	0.90	0.81	0.75	0.66	0.57	0.49	0.41	0.34
10	24.70	239.4	1.45	1.33	1.22	1.17	1.11	1.05	1.00	0.91	0.85	0.75	0.66	0.58	0.50	0.42
15	29.70	249.8	1.55	1.43	1.31	1.26	1.20	1.14	1.09	1.00	0.94	0.84	0.75	0.66	0.57	0.49
20	34.70	258.8	1.63	1.52	1.40	1.33	1.28	1.23	1.17	1.07	1.02	0.92	0.82	0.73	0.64	0.55
25	39.70	266.8	1.71	1.59	1.47	1.41	1.36	1.30	1.25	1.15	1.09	0.98	0.89	0.80	0.71	0.62
30	44.70	274.0	1.78	1.66	1.54	1.48	1.42	1.37	1.31	1.21	1.15	1.05	0.95	0.85	0.76	0.68
40	54.70	286.7	1.91	1.79	1.66	1.61	1.54	1.49	1.43	1.32	1.27	1.16	1.06	0.97	0.87	0.78
50	64.70	297.7	2.02	1.90	1.77	1.71	1.65	1.60	1.54	1.42	1.37	1.26	1.16	1.06	0.96	0.87
60	74.70	307.3	2.10	2.00	1.87	1.81	1.75	1.69	1.63	1.51	1.47	1.35	1.25	1.15	1.05	0.95
70	84.70	316.0	2.20	2.09	1.95	1.89	1.83	1.77	1.71	1.59	1.55	1.44	1.33	1.23	1.12	1.03
80	94.70	323.9	2.27	2.17	2.03	1.97	1.91	1.85	1.80	1.69	1.63	1.52	1.41	1.31	1.20	1.10
90	104.70	331.2	2.36	2.24	2.11	2.05	1.98	1.93	1.87	1.74	1.70	1.59	1.48	1.38	1.28	1.17
100	114.70	337.9	2.43	2.31	2.18	2.11	2.05	2.00	1.94	1.81	1.77	1.65	1.54	1.44	1.33	1.23
125	139.70	352.9	2.59	2.47	2.33	2.27	2.21	2.16	2.10	1.96	1.92	1.80	1.69	1.59	1.48	1.38
150	164.70	365.9	2.73	2.62	2.47	2.43	2.35	2.29	2.23	2.08	2.05	1.94	1.82	1.72	1.61	1.51
175	189.70	377.4	2.86	2.74	2.60	2.54	2.47	2.41	2.35	2.21	2.17	2.05	1.95	1.85	1.73	1.63
200	214.70	387.8	2.95	2.85	2.71	2.63	2.58	2.52	2.47	2.31	2.29	2.17	2.06	1.96	1.84	1.75

From Keenan and Keyes — Linear Interpolation.

Note: Gauge pressure should be corrected for altitude.

CORRECTION FACTORS FOR WATER TEMPERATURES AND AIR TEMPERATURES OTHER THAN STANDARD

AVERAGE WATER TEMP. °F	ENTERING AIR TEMPERATURE, °F														
	45	55	STD	70	75	80	85	90	95	100	110	120	130	140	150
90	.19	.13	.11	.06											
100	.25	.19	.15	.11	.08	.06									
110	.31	.25	.20	.16	.13	.11	.08	.06							
120	.38	.31	.26	.21	.19	.16	.13	.11	.08	.06					
130	.45	.38	.33	.28	.25	.21	.19	.16	.13	.11	.06				
140	.53	.45	.40	.34	.31	.28	.25	.21	.19	.16	.11	.06			
150	.61	.53	.45	.41	.38	.34	.31	.28	.25	.21	.16	.11	.06		
160	.69	.61	.53	.49	.45	.41	.38	.34	.31	.28	.21	.16	.11	.06	
170	.77	.69	.61	.57	.53	.49	.45	.41	.38	.34	.28	.21	.16	.11	.06
180	.86	.77	.69	.65	.61	.57	.53	.49	.45	.41	.34	.28	.21	.16	.11
190	.95	.86	.78	.73	.69	.65	.61	.57	.53	.49	.41	.34	.28	.21	.16
200	1.05	.95	.86	.82	.77	.73	.69	.65	.61	.57	.49	.41	.34	.28	.21
210	1.14	1.05	.95	.91	.86	.82	.77	.73	.69	.65	.57	.49	.41	.34	.28
▶ 215 (STD.)	1.19	1.09	1.00	.95	.91	.86	.82	.77	.73	.69	.61	.53	.45	.38	.31
220	1.24	1.14	1.05	1.00	.95	.91	.86	.82	.77	.73	.65	.57	.49	.41	.34
230	1.34	1.24	1.14	1.09	1.05	1.00	.95	.91	.86	.82	.73	.65	.57	.49	.41
240	1.44	1.34	1.25	1.19	1.14	1.09	1.05	1.00	.95	.91	.82	.73	.65	.57	.49
250	1.55	1.44	1.34	1.29	1.24	1.19	1.14	1.09	1.05	1.00	.91	.82	.73	.65	.57
260	1.66	1.55	1.44	1.39	1.34	1.29	1.24	1.19	1.14	1.09	1.00	.91	.82	.73	.65
270	1.76	1.66	1.55	1.50	1.44	1.39	1.34	1.29	1.24	1.19	1.09	1.00	.91	.82	.73
280	1.87	1.76	1.66	1.60	1.55	1.50	1.44	1.39	1.34	1.29	1.19	1.09	1.00	.91	.82
290	1.99	1.87	1.76	1.71	1.66	1.60	1.55	1.50	1.44	1.39	1.29	1.19	1.09	1.00	.91
300	2.10	1.99	1.87	1.82	1.76	1.71	1.66	1.60	1.55	1.50	1.39	1.29	1.19	1.09	1.00