

LV4 Slip Jointed Enclosure

Specification

ENCLOSURE:

- STYLE: Flat Top, Rounded Outlet
 OUTLET: Stamped Louvers
 Pencil Proof
 LENGTHS: 2'0" thru 8'0" in 6" Increments
 MAT'L: 16 Ga. CRS (Std)
 14 Ga. Aluminum (Opt'l)
 HEIGHT: 14"
 20"
 24"
 30"
 36"
 FINISH: Baked Powder (Std)
 Baked Enamel (Opt'l)

ACCESSORIES:

LV Overlapping Type
 All accessories return to the wall at the bottom and have pre-punched holes for fastening to the wall.

ELEMENT:

- TYPE: Cu/Al (Mechanically Expanded)
 LENGTHS: 2'0" thru 12'6" in 1" Increments for 1" & 1-1/4" Cu.
 2'0" thru 8'0" in 1" Increments for 3/4" Cu.
 One End Flared (Std)
 See Catalog for Working Pressures

DAMPER:

- Damper Blades Factory Installed
 Knob Damper (Opt'l)
 Tamper Resistant (Opt'l)

BACKPLATE:

- TYPE: Partial B/P
 LENGTHS: 8'0" Only
 MAT'L: 20 Ga. Prepainted (Std)
 18 Ga. Galvannealed (Opt'l)
 TYPE: Full Ht. B/P (Opt'l)
 LENGTHS: 2'0" thru 8'0" in 6" Increments
 MAT'L: 20 Ga. Galvannealed (Opt'l)
 20 Ga. Painted (Opt'l)
 18 Ga. Painted (Opt'l)

AIRSEAL:

- 1/8" x 3/8" Closed Cell (Opt'l)

BRACKETS:

- Water Bracket (with Stand-Off)
 Stand-Off not required with 14", 20" & 24"

- B.B. Hanger, Bracket Mtd
 B.B. Hanger, Wall Mtd
 Wall Mtd B.B. Hanger required for 3rd Tier Element

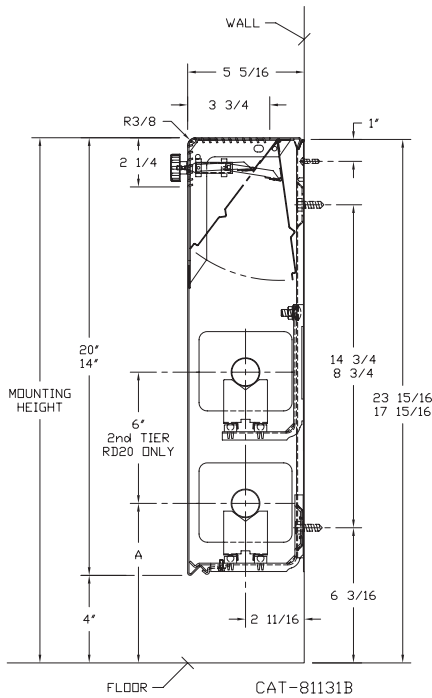

ELEMENT TUBE SIZE	ELEMENT FIN SIZE HEIGHT x WIDTH	CRADLE	A
3/4" COPPER	3 5/8 x 4 1/4	2	7"
3/4" COPPER	4 1/4 x 4 1/4	3A	7 3/8"

- LV4-R 14
 LV4-R 20

- LV4-R 24
 LV4-R 30
 LV4-R 36

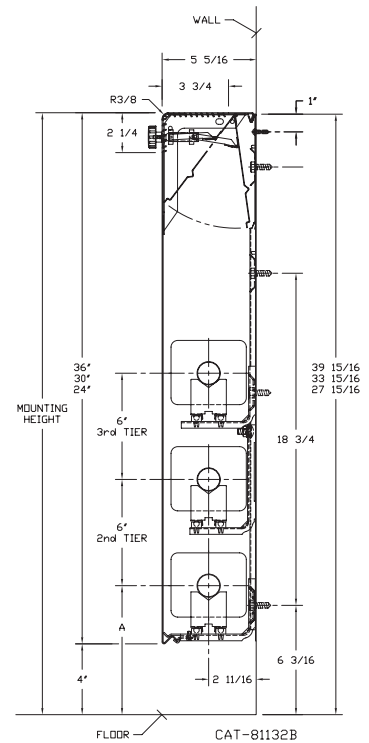

260 North Elm St., Westfield, MA 01085
 (413) 568-9571 Fax: (413) 564-5661
 www.vulcanrad.com



PROJECT: _____ DATE: _____
 LOCATION: _____
 ARCHITECT: _____
 ENGINEER: _____
 CONTRACTOR: _____
 PO NUMBER: _____

LV4-R Style "R" Flat Top Enclosures

Copper/Aluminum Elements

ALL RATINGS ARE BASED ON 3 FPS WATER VELOCITY, 65°EAT

TUBE SIZE	CATALOG DESIGNATION	FIN SIZE HEIGHT X WIDTH	FIN PER FT.	FIN THICKNESS IN INCHES	ENCL DEPTH AND HEIGHT IN INCHES	TIERS AND CENTERS IN INCHES	MTG. HEIGHT IN INCHES	STEAM 215°F FACTOR	HOT WATER (AVG.)										
									200°F	190°F	180°F	170°F	160°F	150°F	140°F	130°F	120°F	110°F	100°F
									0.86	0.78	0.69	0.61	0.53	0.45	.40	.33	.26	.20	.15
3/4"	VC3/4-433	3-5/8" x 4-1/4"	32	.020	14B	1	18	1470	1260	1150	1010	900	780	660	590	490	380	290	220
					20B	1	24	1530	1320	1190	1060	930	810	690	610	500	400	310	230
					20B	2-6 CL	24	2290	1970	1790	1580	1400	1210	1030	920	760	600	460	340
					24B	1	28	1620	1390	1260	1120	990	860	730	650	530	420	320	240
					24B	2-6 CL	28	2410	2070	1880	1660	1470	1280	1080	960	800	630	480	360
					24B	3-6 CL	28	2770	2380	2160	1910	1690	1470	1250	1110	910	720	550	420
					30B	1	34	1710	1470	1330	1180	1040	910	770	680	560	440	340	260
					30B	2-6 CL	34	2470	2120	1930	1700	1510	1310	1110	990	820	640	490	370
					30B	3-6 CL	34	2840	2440	2220	1960	1730	1510	1280	1140	940	740	570	430
					36B	1	40	1800	1550	1400	1240	1100	950	810	720	590	470	360	270
					36B	2-6 CL	40	2550	2190	1990	1760	1560	1350	1150	1020	840	660	510	380
					36B	3-6 CL	40	2930	2520	2290	2020	1790	1550	1320	1170	970	760	590	440
3/4"	VC3/4-434	3-5/8" x 4-1/4"	40	.020	14B	1	18	1690	1450	1320	1170	1030	900	760	680	560	440	340	250
					20B	1	24	1790	1540	1400	1240	1090	950	810	720	590	470	360	270
					20B	2-6 CL	24	2490	2140	1940	1720	1520	1320	1120	1000	820	650	500	370
					24B	1	28	1870	1610	1460	1290	1140	990	840	750	620	490	370	280
					24B	2-6 CL	28	2590	2230	2020	1790	1580	1370	1170	1040	850	670	520	390
					24B	3-6 CL	28	2950	2540	2300	2040	1800	1560	1330	1180	970	770	590	440
					30B	1	34	2000	1720	1560	1380	1220	1060	900	800	660	520	400	300
					30B	2-6 CL	34	2780	2390	2170	1920	1700	1470	1250	1110	920	720	560	420
					30B	3-6 CL	34	3170	2730	2470	2190	1930	1680	1430	1270	1050	820	630	480
					36B	1	40	2130	1830	1660	1470	1300	1130	960	850	700	550	430	320
					36B	2-6 CL	40	2900	2490	2260	2000	1770	1540	1310	1160	960	750	580	440
					36B	3-6 CL	40	3310	2850	2580	2280	2020	1750	1490	1320	1090	860	660	500
3/4"	VC3/4-435	3-5/8" x 4-1/4"	50	.020	14B	1	18	1930	1660	1510	1330	1180	1020	870	770	640	500	390	290
					20B	1	24	2110	1810	1650	1460	1290	1120	950	840	700	550	420	320
					20B	2-6 CL	24	2640	2270	2060	1820	1610	1400	1190	1060	870	690	530	400
					24B	1	28	2210	1900	1720	1520	1350	1170	990	880	730	570	440	330
					24B	2-6 CL	28	2820	2430	2200	1950	1720	1490	1270	1130	930	730	560	420
					24B	3-6 CL	28	3190	2740	2490	2200	1950	1690	1440	1280	1050	830	640	480
					30B	1	34	2410	2070	1880	1660	1470	1280	1080	960	800	630	480	360
					30B	2-6 CL	34	3090	2660	2410	2130	1880	1640	1390	1240	1020	800	620	460
					30B	3-6 CL	34	3490	3000	2720	2410	2130	1850	1570	1400	1150	910	700	520
					36B	1	40	2540	2180	1980	1750	1550	1350	1140	1020	840	660	510	380
					36B	2-6 CL	40	3200	2750	2500	2210	1950	1700	1440	1280	1060	830	640	480
					36B	3-6 CL	40	3620	3110	2820	2500	2210	1920	1630	1450	1190	940	720	540
3/4"	VC3/4-43	4-1/4" SQ.	32	.020	14B	1	18	1690	1450	1320	1170	1030	900	760	680	560	440	340	250
					20B	1	24	1780	1530	1390	1230	1090	940	800	710	590	460	360	270
					20B	2-6 CL	24	2650	2280	2070	1830	1620	1400	1190	1060	870	690	530	400
					24B	1	28	1870	1610	1460	1290	1140	990	840	750	620	490	370	280
					24B	2-6 CL	28	2740	2360	2140	1890	1670	1450	1230	1100	900	710	550	410
					24B	3-6 CL	28	3200	2750	2500	2210	1950	1700	1440	1280	1060	830	640	480
					30B	1	34	1960	1690	1530	1350	1200	1040	880	780	650	510	390	290
					30B	2-6 CL	34	2820	2430	2200	1950	1720	1490	1270	1130	930	730	560	420
					30B	3-6 CL	34	3240	2790	2530	2240	1980	1720	1460	1300	1070	840	650	490
					36B	1	40	2090	1800	1630	1440	1270	1110	940	840	690	540	420	310
					36B	2-6 CL	40	2930	2520	2290	2020	1790	1550	1320	1170	970	760	590	440
					36B	3-6 CL	40	3370	2900	2630	2330	2060	1790	1520	1350	1110	860	670	510
3/4"	VC3/4-44	4-1/4" SQ.	40	.020	14B	1	18	2100	1810	1640	1450	1280	1110	950	840	690	550	420	320
					20B	1	24	2250	1940	1760	1550	1370	1190	1010	900	740	590	450	340
					20B	2-6 CL	24	3180	2730	2480	2190	1940	1690	1430	1270	1050	830	640	480
					24B	1	28	2350	2020	1830	1620	1430	1250	1060	940	780	610	470	350
					24B	2-6 CL	28	3270	2810	2550	2260	1990	1730	1470	1310	1080	850	650	490
					24B	3-6 CL	28	3730	3210	2910	2570	2280	1980	1680	1490	1230	970	750	560
					30B	1	34	2490	2140	1940	1720	1520	1320	1120	1000	820	650	500	370
					30B	2-6 CL	34	3380	2910	2640	2330	2060	1790	1520	1350	1120	880	680	510
					30B	3-6 CL	34	3850	3310	3000	2660	2350	2040	1730	1540	1270	1000	770	580
					36B	1	40	2630	2260	2050	1810	1600	1390	1180	1050	870	680	530	390
					36B	2-6 CL	40	3510	3020	2740	2420	2140	1860	1580	1400	1160	910	700	530
					36B	3-6 CL	40	4000	3440	3120	2760	2440	2120	1800	1600	1320	1040	800	600
3/4"	VC3/4-45	4-1/4" SQ.	50	.020	14B	1	18	2210	1900	1720	1520	1350	1170	990	880	730	570	440	330
					20B	1	24	2420	2080	1890	1670	1480	1280	1090	970	800	630	480	360
					20B	2-6 CL	24	3200	2750	2500	2210	1950	1700	1440	1280	1060	830	640	480
					24B	1	28	2550	2190	1990	1760	1560	1350	1150	1020	840	660	510	380
					24B	2-6 CL	28	3380	2910	2640	2330	2060	1790	1520	1350	1120	880	680	510
					24B	3-6 CL	28	3820	3290	2980	2640	2330	2020	1720	1530	1260	990	760	570
					30B	1	34	2760	2370	2150	1900	1680	1460	1240	1100	910	720	550	410
					30B	2-6 CL	34	3570	3070	2780	2460	2180	1890	1610	1430	1180	930	710	540
					30B	3-6 CL	34	4030	3470	3140	2780	2460	2140	1810	1610	1330	1050	810	600
					36B	1	40	2970	2550	2320	2050	1810	1570	1340	1190	980	770	590	450
					36B	2-6 CL	40	3760	3230	2930	2590	2290	1990	1690	1500	1240	980	750	560
					36B	3-6 CL	40	4250	3660	3320	2930	2590	2250	1910	1700	1400	1110	850	640

Design Data

CORRECTION FACTOR CHART for Non-Standard Mounting Heights

MOUNTING HEIGHT (Inches)	ENCLOSURE STYLE						
	BARE FIN ALL SIZES	FRONT OUTLET	FT (FRONT & TOP)		SLOPE		
			3 1/4" FINS	4 1/4" FINS	2 3/4" FINS	3 1/4" FINS	4 1/4" FINS
40 or more	1.000	1.000	1.000	1.000	1.000	1.000	1.000
38	1.000	1.000	1.000	1.000	1.000	1.000	1.003
36	1.000	1.004	1.005	1.005	1.006	1.007	1.009
34	1.010	1.014	1.011	1.010	1.012	1.013	1.016
32	1.020	1.024	1.017	1.015	1.019	1.020	1.025
30	1.030	1.039	1.029	1.024	1.031	1.033	1.039
29	1.040	1.049	1.035	1.029	1.038	1.040	1.045
28	1.050	1.059	1.041	1.034	1.045	1.047	1.052
27	1.060	1.069	1.046	1.039	1.051	1.053	1.059
26	1.070	1.079	1.052	1.044	1.058	1.060	1.065
25	1.080	1.089	1.058	1.049	1.065	1.067	1.072
24	1.090	1.099	1.064	1.054	1.071	1.073	1.079
23	1.100	1.109	1.070	1.059	1.078	1.080	1.085
22	1.110	1.119	1.076	1.064	1.085	1.087	1.092
21	1.120	1.129	1.082	1.069	1.091	1.093	1.099
20	1.130	1.139	1.088	1.074	1.098	1.100	1.100
19	1.140	1.149	1.089	1.075	1.100	1.100	1.100
18 or less	1.150	1.150	1.089	1.075	1.100	1.100	1.100

TOP OUTLET "T" IS NOT AFFECTED.

The AHRI Ratings cataloged include the factor shown for the recommended mounting height.

If the unit is to be installed at a different height than that recommended, the AHRI Rating (except for Top Outlet) must be adjusted as follows: AHRI Rating multiplied by

**Factor from Table Above
for actual mounting height**

**Factor from Table Above
for recommended mounting height**

EXAMPLE: Corrected steam rating for 1 row C3/4-45 element in JVB-F14 (14" high enclosures) mounted 30" above floor in lieu of the 18" recommended.

FORMULA:

Catalog Rating x $\frac{\text{Factor at 30" Height}}{\text{Factor at 18" Height}}$

SOLUTION: $1950 \times \frac{1.039}{1.150} = 1760 \text{ BTU/Hr.}$

DYNAMIC FORMULAS

$$\text{BTU} = \text{GPM} \times 500 \times \text{TD}$$

$$\text{GPM} = \left(\frac{\text{BTU}}{500} \right) \div \text{TD}$$

$$\text{TD} = \left(\frac{\text{BTU}}{500} \right) \div \text{GPM}$$

Design Data

COMMERCIAL FINNED TUBE RATING CORRECTION CHARTS

CATALOG FINNED TUBE RATINGS ARE BASED UPON THE FOLLOWING CONDITIONS:

- 215°F AVERAGE WATER OR STEAM TEMPERATURE
- 65°F ENTERING AIR TEMPERATURE
- 3 FEET PER SECOND WATER FLOW RATE
- CATALOG MOUNTING HEIGHT

USE THE FOLLOWING CALCULATION WITH CORRECTION FACTORS FOR JOB CONDITIONS TO DETERMINE CORRECTED RATING:

$$\text{CORRECTED RATING} = (215^\circ\text{F CATALOG RATING}) \times \left(\frac{\text{CORRECTION FACTOR FOR STEAM OR WATER AND AVERAGE AIR TEMP.}}{\quad} \right) \times \left(\frac{\text{CORRECTION FACTOR FOR FLOW RATE}}{\quad} \right) \times \left(\frac{\text{CORRECTION FOR MOUNTING HTG.-SEE CATALOG RATING}}{\quad} \right)$$

USE THE FOLLOWING CHARTS TO SELECT CORRECTION FACTORS

CHART/WATER VEL./CORR. FACTOR / PRESS. DROP/TOTAL BTU.

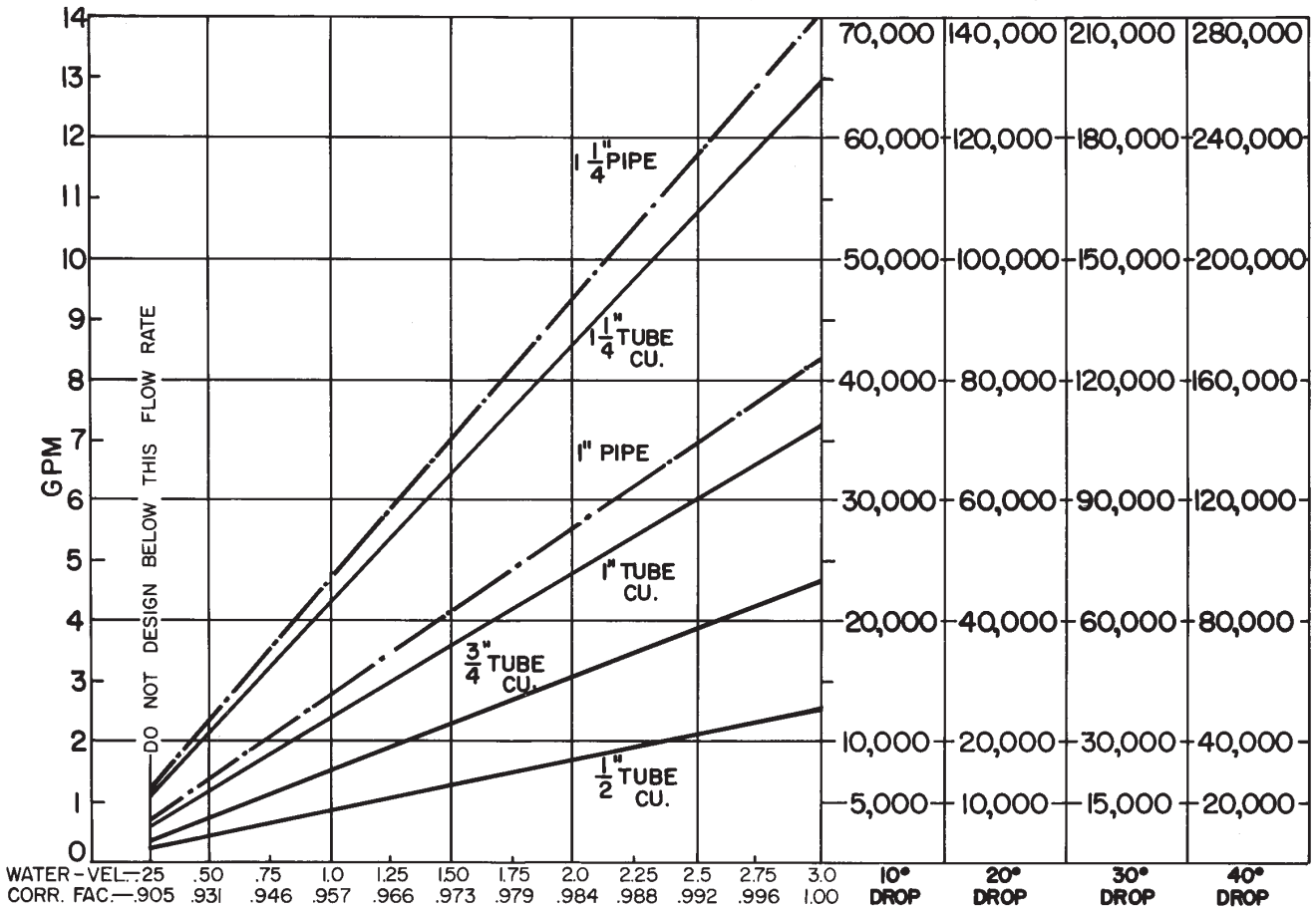

1/2" COP ALUM.	.180	.233	.333	.533	.916											
3/4" COP ALUM.	.5	1.5	3.16	5.4	6.25											
1" COP ALUM.	.233	.41	.83	1.45	2.16	2.83	3.66									
1" PIPE	.37	.79	1.3	2.00	2.70	3.70	4.80									
1 1/4" COP ALUM.	.16	.33	.55	.79	1.08	1.33	1.8	2.25	2.26	2.91	3.3					
1 1/4" PIPE	.09	.18	.31	.5	.70	1.0	1.1	1.3	1.6	1.8	2.58	2.3	3.3			

PRESSURE DROP PER 100 LINEAR FT., IN FEET OF HEAD

Design Data

INLET AIR CORRECTION FACTOR

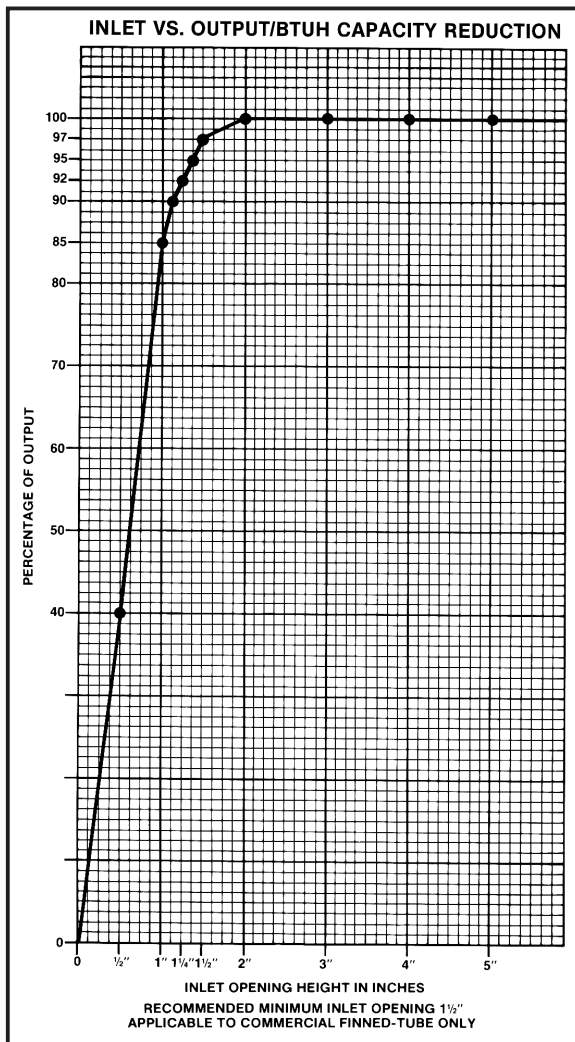

GUARANTEED WORKING PRESSURES

1" IPS — 780 AT TEMPERATURES UP TO 650°F.
 1 1/4" IPS — 660 AT TEMPERATURES UP TO 650°F.
 2" IPS — 405 AT TEMPERATURES UP TO 650°F.
 1 1/4" CU — 194 AT TEMPERATURES UP TO 300°F.
 1" CU — 204 AT TEMPERATURES UP TO 300°F.
 3/4" CU — 218 PSI AT TEMPERATURES UP TO 300°F.
 MAXIMUM PRESSURES AT OTHER TEMPERATURES ARE AVAILABLE UPON REQUEST.

RATE OF PITCH FOR STEAM 1/2" DROP OVER 20 FT. RUN.

PIPE WATER CAPACITIES AND QUANTITIES CIRCULATED AT VELOCITY OF 3* FEET PER SECOND			
Pipe Size	Gals. Per Linear Ft.	Gals./Min. @ 3' Sec. Vel.*	Lbs./Hr. @ 3' Sec. Vel.*
1/2"	.016	2.88	1440
3/4"	.023	4.14	2070
1"	.040	7.20	3600
1 1/4"	.063	11.34	5660
1 1/2"	.102	18.36	9160
2"	.170	30.60	15300
2 1/2"	.275	49.50	24850
3"	.390	70.20	35000

*3 Ft./Sec. Velocity is Basic for Hot Water Rating Factors Shown on this Page.

$$\text{VELOCITY FT./SEC.} = \frac{\text{LBS. PER HOUR}}{(\text{GALS. PER FT.}) (3600) (8.3)}$$

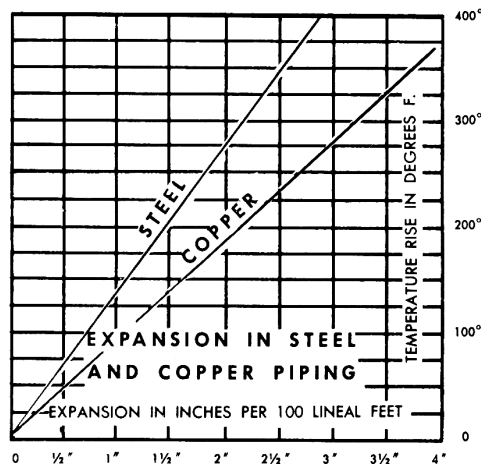

CORRECTIONS WHEN USING GLYCOL SOLUTION IN SYSTEM†

		Ethylene Glycol	
		Ethylene Glycol	Propylene Glycol
1. Heat transfer @ 180°F, with no increase in flow rate	20% Solution	.946*	.982*
	30% Solution	.913*	.961*
	40% Solution	.879*	.934*
	50% Solution	.842*	.902*
2. GPM req'd. @ 180°F, (no correction to pump curve)	20°Δt	114%*	110%*
3. Pump head req'd. @ 180°F, with increase in GPM		123%*	123%*
4. Freezing Point	50% by volume	-37°F	-28°F
	40%	-14°F	-13°F
	30%	+ 2°F	+ 4°F
	20%	+15°F	+17°F

*Compared To Water.

ALTITUDE FACTORS

Approximate factors for convective heat value at varying altitudes

Altitude	Ferrous Units	Copper Alum. Units
Sea Level	1.000	1.000
1,000 ft.	.984	.969
2,000 ft.	.968	.938
3,000 ft.	.952	.908
4,000 ft.	.936	.878
5,000 ft.	.920	.850
6,000 ft.	.904	.822
7,000 ft.	.889	.795
8,000 ft.	.874	.768
9,000 ft.	.859	.743
10,000 ft.	.844	.718
15,000 ft.	.771	.603
20,000 ft.	.703	.502

† Note: The heat output of standard heat distributing units is not affected enough to be considered in sizing the units, when the flow rate has been increased as shown at left. If not increased, apply appropriate heat transfer correction factor indicated.

Design Data

CORRECTION FACTORS FOR STEAM PRESSURES AND AIR TEMPERATURES OTHER THAN STANDARD

STEAM		ENTERING AIR TEMPERATURE, °F														
Pressure		Temp.	STD													
Gauge	Abs. Psi	°F	45	55	65	70	75	80	85	90	100	110	120	130	140	150
(Vac) 15 Hg	7.32	178.9	0.90	0.80	0.70	0.65	0.60	0.56	0.51	0.45	0.39	0.32	0.25	0.18	0.13	0.08
(Vac) 10	9.78	192.2	1.02	0.91	0.81	0.76	0.71	0.66	0.62	0.55	0.48	0.40	0.33	0.26	0.20	0.14
(Vac) 5	12.25	202.9	1.11	1.00	0.90	0.85	0.79	0.75	0.70	0.63	0.56	0.48	0.40	0.33	0.27	0.20
(Vac) 0 Psi	14.696	212.0	1.19	1.09	0.97	0.92	0.87	0.82	0.77	0.70	0.63	0.54	0.46	0.38	0.31	0.25
▶ .899	15.595	215.0	1.22	1.11	1.00	0.95	0.90	0.84	0.80	0.75	0.65	0.57	0.48	0.40	0.33	0.26
5	19.70	227.1	1.34	1.22	1.11	1.05	1.00	0.95	0.90	0.81	0.75	0.66	0.57	0.49	0.41	0.34
10	24.70	239.4	1.45	1.33	1.22	1.17	1.11	1.05	1.00	0.91	0.85	0.75	0.66	0.58	0.50	0.42
15	29.70	249.8	1.55	1.43	1.31	1.26	1.20	1.14	1.09	1.00	0.94	0.84	0.75	0.66	0.57	0.49
20	34.70	258.8	1.63	1.52	1.40	1.33	1.28	1.23	1.17	1.07	1.02	0.92	0.82	0.73	0.64	0.55
2530	39.70	266.8	1.71	1.59	1.47	1.41	1.36	1.30	1.25	1.15	1.09	0.98	0.89	0.80	0.71	0.62
40	44.70	274.0	1.78	1.66	1.54	1.48	1.42	1.37	1.31	1.21	1.15	1.05	0.95	0.85	0.76	0.68
50	54.70	286.7	1.91	1.79	1.66	1.61	1.54	1.49	1.43	1.32	1.27	1.16	1.06	0.97	0.87	0.78
60	64.70	297.7	2.02	1.90	1.77	1.71	1.65	1.60	1.54	1.42	1.37	1.26	1.16	1.06	0.96	0.87
70	74.70	307.3	2.10	2.00	1.87	1.81	1.75	1.69	1.63	1.51	1.47	1.35	1.25	1.15	1.05	0.95
80	84.70	316.0	2.20	2.09	1.95	1.89	1.83	1.77	1.71	1.59	1.55	1.44	1.33	1.23	1.12	1.03
90	94.70	323.9	2.27	2.17	2.03	1.97	1.91	1.85	1.80	1.69	1.63	1.52	1.41	1.31	1.20	1.10
100	104.70	331.2	2.36	2.24	2.11	2.05	1.98	1.93	1.87	1.74	1.70	1.59	1.48	1.38	1.28	1.17
125	114.70	337.9	2.43	2.31	2.18	2.11	2.05	2.00	1.94	1.81	1.77	1.65	1.54	1.44	1.33	1.23
150	139.70	352.9	2.59	2.47	2.33	2.27	2.21	2.16	2.10	1.96	1.92	1.80	1.69	1.59	1.48	1.38
175	164.70	365.9	2.73	2.62	2.47	2.43	2.35	2.29	2.23	2.08	2.05	1.94	1.82	1.72	1.61	1.51
200	189.70	377.4	2.86	2.74	2.60	2.54	2.47	2.41	2.35	2.21	2.17	2.05	1.95	1.85	1.73	1.63
	214.70	387.8	2.95	2.85	2.71	2.63	2.58	2.52	2.47	2.31	2.29	2.17	2.06	1.96	1.84	1.75

From Keenan and Keyes — Linear Interpolation. NOTE: Gauge pressure should be corrected for altitude.

CORRECTION FACTORS FOR WATER TEMPERATURES AND AIR TEMPERATURES OTHER THAN STANDARD

AVERAGE WATER TEMP. °F	ENTERING AIR TEMPERATURE, °F														
	45	55	STD	70	75	80	85	90	95	100	110	120	130	140	150
90	.19	.13	.11	.06											
100	.25	.19	.15	.11	.08	.06									
110	.31	.25	.20	.16	.13	.11	.08	.06							
120	.38	.31	.26	.21	.19	.16	.13	.11	.08	.06					
130	.45	.38	.33	.28	.25	.21	.19	.16	.13	.11	.06				
140	.53	.45	.40	.34	.31	.28	.25	.21	.19	.16	.11	.06			
150	.61	.53	.45	.41	.38	.34	.31	.28	.25	.21	.16	.11	.06		
160	.69	.61	.53	.49	.45	.41	.38	.34	.31	.28	.21	.16	.11	.06	
170	.77	.69	.61	.57	.53	.49	.45	.41	.38	.34	.28	.21	.16	.11	.06
180	.86	.77	.69	.65	.61	.57	.53	.49	.45	.41	.34	.28	.21	.16	.11
190	.95	.86	.78	.73	.69	.65	.61	.57	.53	.49	.41	.34	.28	.21	.16
200	1.05	.95	.86	.82	.77	.73	.69	.65	.61	.57	.49	.41	.34	.28	.21
210	1.14	1.05	.95	.91	.86	.82	.77	.73	.69	.65	.57	.49	.41	.34	.28
▶ 215 (STD.)	1.19	1.09	1.00	.95	.91	.86	.82	.77	.73	.69	.61	.53	.45	.38	.31
220	1.24	1.14	1.05	1.00	.95	.91	.86	.82	.77	.73	.65	.57	.49	.41	.34
230	1.34	1.24	1.14	1.09	1.05	1.00	.95	.91	.86	.82	.73	.65	.57	.49	.41
240	1.44	1.34	1.25	1.19	1.14	1.09	1.05	1.00	.95	.91	.82	.73	.65	.57	.49
250	1.55	1.44	1.34	1.29	1.24	1.19	1.14	1.09	1.05	1.00	.91	.82	.73	.65	.57
260	1.66	1.55	1.44	1.39	1.34	1.29	1.24	1.19	1.14	1.09	1.00	.91	.82	.73	.65
270	1.76	1.66	1.55	1.50	1.44	1.39	1.34	1.29	1.24	1.19	1.09	1.00	.91	.82	.73
280	1.87	1.76	1.66	1.60	1.55	1.50	1.44	1.39	1.34	1.29	1.19	1.09	1.00	.91	.82
290	1.99	1.87	1.76	1.71	1.66	1.60	1.55	1.50	1.44	1.39	1.29	1.19	1.09	1.00	.91
300	2.10	1.99	1.87	1.82	1.76	1.71	1.66	1.60	1.55	1.50	1.39	1.29	1.19	1.09	1.00