

# CONVECTOR

FS-A / FSG-A  
Flat Top Cabinet  
Wall/Floor Mtd.

## Submittal

### Specification

FS-A Arched Inlet

**FRONT and LINER:**

STYLE: Front Outlet  
OUTLET: Stamped Louvers  
Pencil Proof

LENGTHS: 20" thru 64" in 4" Increments

MAT'L: Cabinet Front and Liner  
 18 Ga./20 Ga. CRS STD.  
 18 Ga./18 Ga. CRS (Opt'l)  
 16 Ga./20 Ga. CRS (Opt'l)  
 16 Ga./18 Ga. CRS (Opt'l)  
 16 Ga./16 Ga. CRS (Opt'l)  
 14 Ga./20 Ga. CRS (Opt'l)  
 14 Ga./18 Ga. CRS (Opt'l)  
 14 Ga./16 Ga. CRS (Opt'l)  
 14 Ga./14 Ga. CRS (Opt'l)

FINISH:  Prime Finish Std.  
 Baked Enamel (Opt'l).

**ELEMENT:**

COIL: Bronze Header 3/4" NPT  
w/Copper Tube/Alum Fins  
(Mechanically Expanded).

**HEADER CONNECTIONS:**

Single Header Both Ends Std.  
 Single Inlet 1 End / Dual Inlet  
 1 End (Opt'l)  
 Dual Inlet Both Ends (Opt'l)

FSG-A Louvered Inlet

**OPTIONAL ACCESSORIES:**

DAMPER: Damper Blades Factory Installed  
 Knob Damper (Opt'l)  
 Tamper Resistant (Opt'l)

**ACCESS DOORS:**

(Opt'l)

**INSULATION:**

Back Only (Opt'l)  
 Back, Sides, Top (Opt'l)

**PIPING KNOCKOUT:**

(Opt'l)

**4" END POCKETS:**

LH (Opt'l)  
 RH (Opt'l)  
 Both Ends (Opt'l)

**PERFORATED FRONT: Consult Factory**

16 Ga. (Opt'l)  
 14 Ga. (Opt'l)

FS-A Arched Inlet

FSG-A Louvered Inlet

**TYPE FS-A / FSG-A**

| MODEL  | D     | L         | H  | B     | J |
|--------|-------|-----------|----|-------|---|
| 4xx-18 | 4-1/4 | 20,24,28, | 18 | 2-1/8 | 2 |
| 4xx-20 |       | 32,36,40, | 20 |       |   |
| 4xx-24 |       | 44,48,52, | 24 |       |   |
| 4xx-26 |       | 56,60,64, | 26 |       |   |
| 4xx-32 |       |           | 32 |       |   |
| 6xx-18 | 6-1/4 | 20,24,28, | 18 | 3-1/8 | 4 |
| 6xx-20 |       | 32,36,40, | 20 |       |   |
| 6xx-24 |       | 44,48,52, | 24 |       |   |
| 6xx-26 |       | 56,60,64, | 26 |       |   |
| 6xx-32 |       |           | 32 |       |   |
| 8xx-18 | 8-1/4 | 20,24,28, | 18 | 4-1/8 | 6 |
| 8xx-20 |       | 32,36,40, | 20 |       |   |
| 8xx-24 |       | 44,48,52, | 24 |       |   |
| 8xx-26 |       | 56,60,64, | 26 |       |   |
| 8xx-32 |       |           | 32 |       |   |

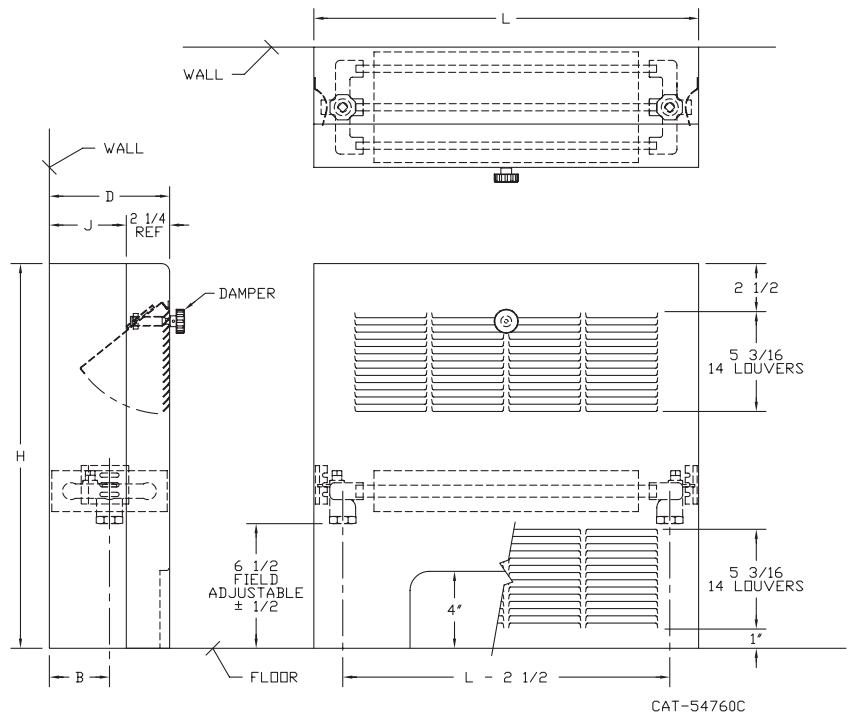

**NOTE: When adding end pockets, liner and front length increase.**



260 North Elm St., Westfield, MA 01085  
 (800) 762-5005 Fax: (413) 572-3764  
 www.turbonicsinc.com



PROJECT: \_\_\_\_\_ DATE: \_\_\_\_\_  
 LOCATION: \_\_\_\_\_  
 ARCHITECT: \_\_\_\_\_  
 ENGINEER: \_\_\_\_\_  
 CONTRACTOR: \_\_\_\_\_  
 PO NUMBER: \_\_\_\_\_

## STEAM RATINGS IN BTU/H (215°F at 65°F EAT)

| DEPTH<br>IN<br>INCHES | LENGTH<br>IN<br>INCHES | FRONT OUTLET, NOMINAL LINER HEIGHT<br>*TYPE FS-A |       |       |       |       |
|-----------------------|------------------------|--|-------|-------|-------|-------|
|                       |                        | 18"  | 20"   | 24"   | 26"   | 32"   |
| <b>4</b>              | 20                     | 2230   | 2495  | 2830  | 2930  | 3120  |
|                       | 24                     | 2760   | 3145  | 3625  | 3720  | 3985  |
|                       | 28                     | 3310   | 3815  | 4345  | 4465  | 4775  |
|                       | 32                     | 3865   | 4490  | 5110  | 5255  | 5665  |
|                       | 36                     | 4370   | 5160  | 5880  | 6025  | 6505  |
|                       | 40                     | 4895   | 5810  | 6600  | 6790  | 7320  |
|                       | 44                     | 5425   | 6480  | 7390  | 7560  | 8160  |
|                       | 48                     | 5950   | 7105  | 8110  | 8350  | 8975  |
|                       | 52                     | 6550   | 7800  | 8855  | 9070  | 9745  |
|                       | 56                     | 7030   | 8450  | 9625  | 9865  | 10630 |
|                       | 60                     | 7655   | 9120  | 10345 | 10610 | 11400 |
|                       | 64                     | 8135   | 9790  | 11135 | 11400 | 12290 |
| <b>6</b>              | 20                     | 3240   | 3625  | 4250  | 4390  | 4850  |
|                       | 24                     | 4030   | 4560  | 5375  | 5570  | 6170  |
|                       | 28                     | 4850   | 5520  | 6480  | 6670  | 7370  |
|                       | 32                     | 5615   | 6480  | 7610  | 7870  | 8690  |
|                       | 36                     | 6430   | 7390  | 8690  | 9025  | 9935  |
|                       | 40                     | 7250   | 8375  | 9815  | 10200 | 11230 |
|                       | 44                     | 8065   | 9290  | 10920 | 11350 | 12480 |
|                       | 48                     | 8880   | 10250 | 12025 | 12455 | 13705 |
|                       | 52                     | 9745   | 11185 | 13105 | 13535 | 14905 |
|                       | 56                     | 10510  | 12145 | 14230 | 14735 | 16225 |
|                       | 60                     | 11400  | 13055 | 15310 | 15840 | 17425 |
|                       | 64                     | 12190  | 14040 | 16440 | 17065 | 18770 |
| <b>8</b>              | 20                     | 4030   | 4535  | 5040  | 5135  | 5570  |
|                       | 24                     | 5110   | 5760  | 6360  | 6575  | 7105  |
|                       | 28                     | 6385   | 6960  | 7680  | 7895  | 8520  |
|                       | 32                     | 7560   | 8185  | 9025  | 9310  | 10055 |
|                       | 36                     | 8710   | 9385  | 10390 | 10705 | 11545 |
|                       | 40                     | 9865   | 10630 | 11760 | 12070 | 13055 |
|                       | 44                     | 11040  | 11830 | 13055 | 13440 | 14545 |
|                       | 48                     | 11950  | 12935 | 14400 | 14810 | 16080 |
|                       | 52                     | 13465  | 14230 | 15670 | 16105 | 17425 |
|                       | 56                     | 14615  | 15505 | 17090 | 17570 | 19010 |
|                       | 60                     | 15770  | 16655 | 18335 | 18840 | 20375 |
|                       | 64                     | 16775  | 17880 | 19750 | 20330 | 21960 |

\* Correction factors for BTU performance from Table 7 must be applied to all units with louvered Inlet.

Correction factors for BTU performance at different Average Water Temperatures, use correction factors from Table 3 of the Correction Factors page.

For other applicable correction factors see the Correction Factors page.

# CONVECTOR BTU CORRECTION FACTORS

**Table 3**

| <b>CONVECTOR CORRECTION FACTORS</b><br>Based on Section 35.4 ASHRAE HVAC Systems and Equipment |                               |      |      |      |      |
|--|-------------------------------|------|------|------|------|
| AVERAGE WATER TEMPERATURE (°F)   | ENTERING AIR TEMPERATURE (°F) |      |      |      |      |
|  | (STD)                         |      |      |      |      |
|  | 55°                           | 60°  | 65°  | 70°  | 75°  |
| 100°   | 0.17                          | 0.14 | 0.12 | 0.09 | 0.07 |
| 110°   | 0.23                          | 0.20 | 0.17 | 0.14 | 0.12 |
| 120°   | 0.29                          | 0.26 | 0.23 | 0.20 | 0.17 |
| 130°   | 0.35                          | 0.32 | 0.29 | 0.26 | 0.23 |
| 140°   | 0.43                          | 0.39 | 0.35 | 0.32 | 0.29 |
| 150°   | 0.50                          | 0.46 | 0.43 | 0.39 | 0.35 |
| 160°   | 0.58                          | 0.54 | 0.51 | 0.47 | 0.43 |
| 170°   | 0.67                          | 0.63 | 0.58 | 0.54 | 0.51 |
| 180°   | 0.76                          | 0.71 | 0.67 | 0.63 | 0.58 |
| 190°   | 0.85                          | 0.81 | 0.76 | 0.71 | 0.67 |
| 200°   | 0.95                          | 0.90 | 0.85 | 0.81 | 0.76 |
| 210°   | 1.05                          | 1.00 | 0.95 | 0.90 | 0.85 |
| 215° (STD)   | 1.10                          | 1.05 | 1.00 | 0.95 | 0.90 |
| 220°   | 1.15                          | 1.10 | 1.05 | 1.00 | 0.95 |
| 230°   | 1.26                          | 1.20 | 1.15 | 1.10 | 1.05 |
| 240°   | 1.37                          | 1.32 | 1.26 | 1.21 | 1.15 |
| 250°   | 1.47                          | 1.43 | 1.37 | 1.32 | 1.27 |

**Table 4**

| <b>CORRECTION FACTORS FOR STEAM PRESSURES OTHER THAN 1 PSI GAUGE*</b>      |                    |      |      |      |      |      |
|--|--------------------|------|------|------|------|------|
|  | PRESSURE PSI GAUGE |      |      |      |      |      |
|  | 5                  | 10   | 15   | 20   | 25   | 50   |
| <b>FACTOR</b>  | 1.12               | 1.25 | 1.36 | 1.46 | 1.56 | 1.93 |
| *Apply factors shown above to the ratings shown on the 215°F ratings page. |                    |      |      |      |      |      |

Note: Max Recommended operating pressure 150 PSIG, (365.9°F).  
For conversion from steam to hot water, use correction factors shown in table 3.

**Table 5**

| <b>CORRECTION FACTORS FOR ACCESS DOORS</b> |   |       |        |       |   |       |        |       |
|--|---|-------|--------|-------|---|-------|--------|-------|
| Length                                     | Free Standing, Non-Recessed<br>Non-Standard Access Door Locations |       |        |       | Semi-Recessed or Fully Recessed<br>Non-Standard Access Door Locations |       |        |       |
|  | 3 or 4  | 3 & 4 | 5 or 6 | 5 & 6 | 3 or 4  | 3 & 4 | 5 or 6 | 5 & 6 |
|  | 20"   | 0.940 | 0.880  | 0.820 | 0.650   | 0.975 | 0.950  | 0.925 |
| 24"  | 0.950   | 0.910 | 0.860  | 0.720 | 0.980   | 0.960 | 0.940  | 0.880 |
| 28"  | 0.960   | 0.920 | 0.890  | 0.770 | 0.982   | 0.968 | 0.948  | 0.902 |
| 32"  | 0.970   | 0.940 | 0.890  | 0.800 | 0.985   | 0.972 | 0.955  | 0.918 |
| 36"  | 0.970   | 0.940 | 0.920  | 0.830 | 0.988   | 0.975 | 0.962  | 0.925 |
| 40"  | 0.970   | 0.950 | 0.920  | 0.850 | 0.990   | 0.978 | 0.970  | 0.932 |
| 44"  | 0.980   | 0.950 | 0.930  | 0.860 | 0.990   | 0.980 | 0.970  | 0.940 |
| 48"  | 0.980   | 0.960 | 0.940  | 0.880 | 0.990   | 0.982 | 0.970  | 0.948 |
| 52"  | 0.980   | 0.960 | 0.950  | 0.890 | 0.992   | 0.985 | 0.978  | 0.955 |
| 56"  | 0.980   | 0.960 | 0.950  | 0.890 | 0.992   | 0.985 | 0.978  | 0.955 |
| 60"  | 0.980   | 0.970 | 0.950  | 0.900 | 0.992   | 0.985 | 0.978  | 0.955 |
| 64"  | 0.980   | 0.970 | 0.950  | 0.910 | 0.992   | 0.988 | 0.978  | 0.962 |

Note: Derating factors do not apply to units with end pockets.

**Table 6**

| WATER FLOW IN G.P.M. | PRESSURE LOSS IN FEET OF WATER |               |               |
|----------------------|--------------------------------|---------------|---------------|
|                      | 4 INCH MODELS                  | 6 INCH MODELS | 8 INCH MODELS |
| .25                  | 0.044                          | —             | —             |
| .50                  | 0.160                          | 0.070         | 0.046         |
| 1                    | 0.597                          | 0.270         | 0.167         |
| 2                    | 2.220                          | 1.047         | 0.616         |
| 3                    | —                              | 2.260         | 1.367         |
| 4                    | —                              | 3.793         | 2.380         |
| 5                    | —                              | —             | 3.673         |

Charted figures showing pressure drop through Convectors with forced hot water. Used for determining pressure head requirement. Based on 64" length units, but applicable to shorter units, as most loss is due to headers.

**Table 7**

| <b>CORRECTION FACTORS FOR INLET GRILLES</b><br>TYPES: FSG-A, SRG-A, RFG-A, FWG-A, PWG-A, SFG-A |               |               |               |
|--|---------------|---------------|---------------|
| DEPTH  | HEIGHT        |               |               |
|  | 16", 18", 20" | 22", 24", 26" | 28", 30", 32" |
| 4"   | 0.97          | 0.98          | 0.99          |
| 6"   | 0.94          | 0.95          | 0.98          |
| 8"   | 0.91          | 0.93          | 0.97          |

Due to the restriction to air flow, the correction factor should be multiplied to the BTU output when inlet grilles are specified.

**ADDITIONAL CORRECTION FACTORS ON NEXT PAGE**

# CONVECTOR BTU CORRECTION FACTORS

## GALLONS PER MINUTE OF HOT WATER REQUIRED

Table 8

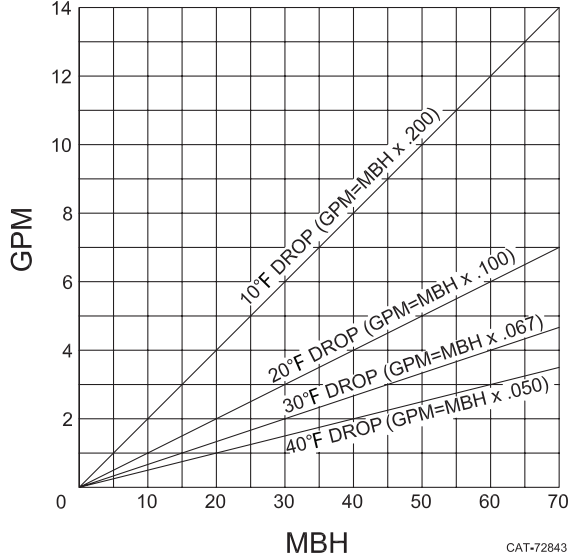

## OUTPUT-FLOW RATE CORRECTIONS

Table 9

| Convactor Depth | Tubes per Element | Min. Flow Rate (0.25 Ft./Sec.) GPM | MBH Based on T.D. & Min. Flow Rate |       |       |       |
|-----------------|-------------------|------------------------------------|------------------------------------|-------|-------|-------|
|                 |                   |                                    | 10TD                               | 20TD  | 30TD  | 40TD  |
| 4"              | 2                 | .15                                | 0.750                              | 1,500 | 2,250 | 3,000 |
| 6"              | 3                 | .225                               | 1.125                              | 2,250 | 3,375 | 4,500 |
| 8"              | 4                 | .30                                | 1.500                              | 3,000 | 4,500 | 6,000 |

NOTE: Table 9 shows MBH which result at specific water temperature drops and minimum water flow rates which are required to maintain turbulent flow within element tubes.

## CONVECTOR COIL

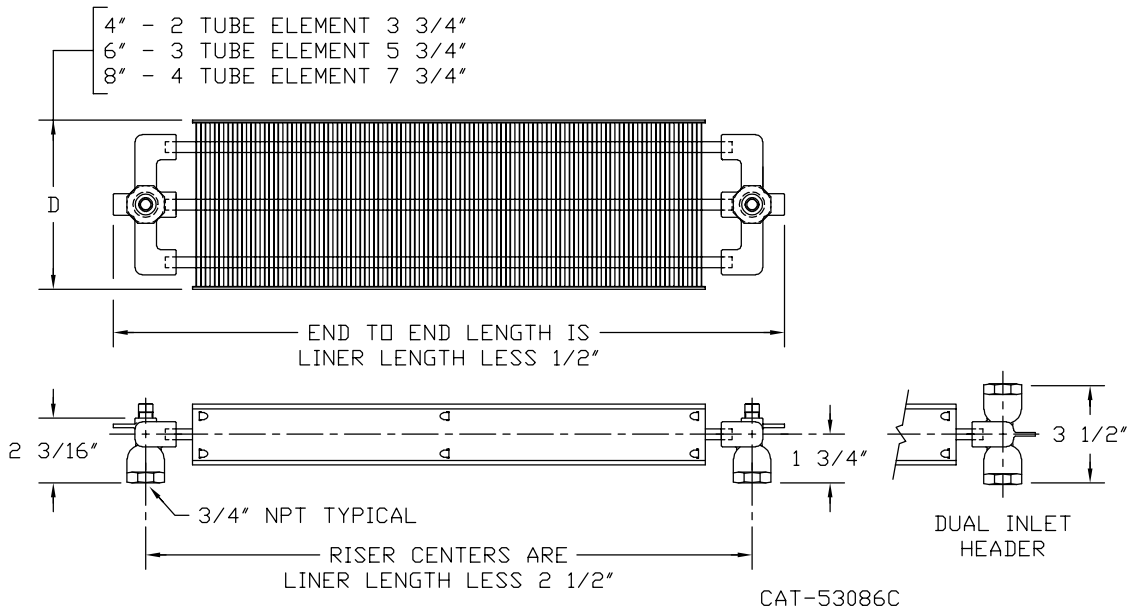

NOTE: When ordering convectors with end pockets always refer to the standard unit length. The overall physical length will increase by 4" for each end pocket. The coil length will remain the standard size. Coil fins are 2-1/2" high by width shown above and are mechanically bonded to copper tube at 6 fins per inch.

