

# TIR Indirect Fired Gas Heating Systems

Technical Guide for:

Outdoor Rooftop Mounted Units To 46,000 CFM And 4,000 MBH Output

Temprite

Keeps You

Warm



# : Indirect Fired : Heating Systems : Technical Guide



In the business of industrial heating, efficient and low-cost operation is essential. Temprite keeps you warm for less.

Since 1963, Temprite has been providing cost-effective, reliable heating solutions. Our proven Indirect Fired Heating Systems adds warm clean air to your work environment, but without the products of combustion in the airstream.

This Technical Guide will help you choose a Temprite Indirect Fired Gas Heating System to provide efficient, cost-effective heating and ventilation for your facility.

The Guide covers:

- Technical Specifications — Configure the right system components (e.g., motors, drive, filter, options, etc.) to meet your needs.
- Installation Information — Plan details of on-site installation.

If you have questions, please contact Temprite's Customer Service Department at 214-638-6010. We'll be glad to help.

**Temprite**

**Keeps You**

**Warm**

# : Table of Contents



Engineering Data .....	4-5
Air Delivery Tables (Heating Only Units) .....	6-9
Dimensional Data – Base Unit and Accessories .....	10
Dimensional Data – Roof Curbs .....	11
Air Delivery Tables (Cooling Units) .....	12
Unit Weights .....	12
Dimensional Data – Cooling Coil Section .....	13
DX Coil Data .....	14
CW Coil Data .....	15
Amp Draw Table .....	16
Typical Gas Piping Layout .....	17
Guide Specifications .....	18-19

# Engineering Data

<b>Capacity and Internal Data</b>						
	<b>Model Size</b>	<b>25</b>	<b>35</b>	<b>40</b>	<b>50</b>	<b>55</b>
SIZE & CAPACITY	Input MBH	312	437	500	625	687
	Output MBH(A)	250	350	400	500	550
FIRING RATE & MANFOLD SIZE	Natural Gas @ 1,000 B.T.U./C.F.	312	437	500	625	687
	Gas Connection @ 7" W.C. (Natural Gas)	¾"	¾"	1"	1"	1"
	Gas Connection @ 14" W.C. (Natural Gas)	¾"	¾"	¾"	¾"	1"
EQUIPMENT DATA	Combustion Air Required (C.F.M.)	80	110	130	160	180
	Exhauster Model	12	12	12	12	12
	Exhauster H.P.	⅓	⅓	⅓	⅓	⅓
	Burner H.P.	⅓	⅓	⅓	⅓	⅓
	Recommended Min. Stack Size – Dia.	8"	8"	8"	8"	8"
	<b>Model Size</b>	<b>65</b>	<b>75</b>	<b>85</b>	<b>100</b>	<b>125</b>
SIZE & CAPACITY	Input MBH	812	987	1,062	1,250	1,562
	Output MBH(A)	650	750	850	1,000	1,250
FIRING RATE & MANFOLD SIZE	Natural Gas @ 1,000 B.T.U./C.F.	812	987	1,062	1,250	1,562
	Gas Connection @ 7" W.C. (Natural Gas)	1¼"	1¼"	1¼"	1½"	1½"
	Gas Connection @ 14" W.C. (Natural Gas)	1"	1"	1"	1"	1¼"
EQUIPMENT DATA	Combustion Air Required (C.F.M.)	210	240	275	325	400
	Exhauster Model	12	12	12	12	18
	Exhauster H.P.	⅓	⅓	½	½	¾
	Burner H.P.	⅓	⅓	⅓	⅓	½
	Recommended Min. Stack Size – Dia.	10"	10"	10"	10"	12"

(A) Based on 80% operating efficiency.

# Engineering Data

Capacity and Internal Data					
	Model Size	150	175	200	250
SIZE & CAPACITY	Input MBH	1,875	2,187	2,500	3,125
	Output MBH(A)	1,500	1,750	2,000	2,500
FIRING RATE & MANFOLD SIZE	Natural Gas @ 1,000 B.T.U./C.F.	1,875	2,187	2,500	3,125
	Gas Connection @ 7" W.C. (Natural Gas)	2"	2"	2"	2"
	Gas Connection @ 14" W.C. (Natural Gas)	1½"	1½"	1½"	2"
EQUIPMENT DATA	Combustion Air Required (C.F.M.)	480	560	650	800
	Exhauster Model	18	18	18	18
	Exhauster H.P.	¾	1½	1½	2
	Burner H.P.	½	½	½	1
	Recommended Min. Stack Size – Dia.	12"	12"	12"	12"
	Model Size	275	300	350	400
SIZE & CAPACITY	Input MBH	3,438	3,750	4,375	5,000
	Output MBH(A)	2,750	3,000	3,500	4,000
FIRING RATE & MANFOLD SIZE	Natural Gas @ 1,000 B.T.U./C.F.	3,438	3,750	4,375	5,000
	Gas Connection @ 7" W.C. (Natural Gas)	2½"	2½"	3"	3"
	Gas Connection @ 14" W.C. (Natural Gas)	2"	2"	2"	2½"
EQUIPMENT DATA	Combustion Air Required (C.F.M.)	880	960	1,120	1,300
	Exhauster Model	18	21	21	21
	Exhauster H.P.	3	3	3	3
	Burner H.P.	1	1	1½	2
	Recommended Min. Stack Size – Dia.	14"	14"	14"	14"

(A) Based on 80% operating efficiency.

# Air Delivery Table

Heating Only Units										
TIR Model No.	Blowers	SCFM	Total External Static Pressure (W.C.)							
			¼"	½"	¾"	1"	1¼"	1½"		
			HP	HP	HP	HP	HP	HP		
25-35	2) 12" x 9"	2300	½	¾	1	1	1½	1½		
		2450	½	¾	1	1	1½	1½		
		2575	¾	¾	1	1	1½	1½		
		2725	¾	1	1	1	1½	1½		
		2900	¾	1	1	1½	1½	1½		
		3250	¾	1	1	1½	1½	2		
		3400	¾	1	1	1½	1½	2		
		3600	1	1	1½	1½	2	2		
		3800	1	1½	1½	2	2	2		
		4050	1	1½	1½	2	2	3		
55/25-35	2) 12" x 12"	3700	¾	1	1½	1½	2	2		
		3900	1	1	1½	1½	2	2		
		4100	1	1½	1½	2	2	3		
		4350	1	1½	1½	2	2	3		
		4600	1½	1½	2	2	3	3		
		4875	1½	1½	2	3	3	3		
		5100	1½	2	2	3	3	3		
		5450	2	2	3	3	3	5		
		5775	2	3	3	3	5	5		
		6000	3	3	3	5	5	5		
		6350	3	3	5	5	5	5		
		75/25-35	2) 15" x 15"	6000	1½	2	3	3	5	5
				6350	2	3	3	3	5	5
6675	2			3	3	5	5	5		
7075	3			3	3	5	5	5		
7300	3			3	5	5	5	5		
7525	3			3	5	5	5	7½		
7700	3			5	5	5	5	7½		
8175	5			5	5	5	7½	7½		
8675	5			5	5	7½	7½	7½		
40-55	2) 12" x 12"			3700	¾	1	1½	1½	2	2
		3900	1	1	1½	1½	2	2		
		4100	1	1½	1½	2	2	3		
		4350	1	1½	1½	2	2	3		
		4600	1½	1½	2	2	3	3		
		4875	1½	1½	2	3	3	3		
		5100	1½	2	2	3	3	3		
		5450	2	2	3	3	3	5		
		5775	2	3	3	3	5	5		
		6000	3	3	3	5	5	5		
		6350	3	3	5	5	5	5		
		75/40-55	2) 15" x 15"	6000	1½	2	3	3	5	5
				6350	2	3	3	3	5	5
6675	2			3	3	5	5	5		
7075	3			3	3	5	5	5		
7300	3			3	5	5	5	5		
7525	3			3	5	5	5	7½		
7700	3			5	5	5	5	7½		
8175	5			5	5	5	7½	7½		
8675	5			5	5	7½	7½	7½		

**NOTES:**

1. The horsepower selections are based on system total external static pressure. To determine total external static pressure, add system duct loss plus all applicable accessory pressure drops listed below:

- A. Fresh Air Inlet Hood & Birdscreen .10" W.C.
- B. Motor Operated Inlet Damper .18" W.C.
- C. V-Bank Filter Section .25" W.C.

2. Select unit size and motor horsepower from above table.

**EXPLANATION OF MODEL NUMBERS:**

**DASH MODEL NUMBERS** – A dash in the model number indicates the BTU range on the heat exchanger.

Example: Model 25-35 has a heat exchanger rating of 250,000-350,000 BTU output.

**SLASH MODEL NUMBERS** – A slash in the model number indicates the use of a larger blower section with a smaller heat exchanger, normally used for low temperature applications. Example: Model 75/25-35 has a 75 size blower section, which offers airflow up to 8675 CFM, with a heat exchanger rating of 250,000-350,000 BTU output.

# Air Delivery Table

Heating Only Units								
TIR Model No.	Blowers	SCFM	Total External Static Pressure (W.C.)					
			¼"	½"	¾"	1"	1¼"	1½"
			HP	HP	HP	HP	HP	HP
100/40-55	2) 18" x 18"	7875	3	5	5	5	7½	7½
		8275	5	5	5	7½	7½	
		8775	5	5	7½	7½	10	
		9250	5	7½	7½	7½	10	
		9750	7½	7½	7½	10	10	
		10,275	7½	7½	7½	10	10	
		10,900	7½	10	10	10	15	
		11,575	10	10	10	15	15	
65-75	2) 15" x 15"	6000	1½	2	3	3	5	5
		6350	2	3	3	3	5	
		6675	2	3	3	5	5	
		7075	3	3	3	5	5	
		7300	3	3	5	5	5	
		7525	3	3	5	5	5	
		7700	3	5	5	5	5	
		8175	5	5	5	5	7½	
8675	5	5	5	7½	7½			
100/65-75	2) 18" x 18"	7875	3	5	5	5	7½	7½
		8275	5	5	5	7½	7½	
		8775	5	5	7½	7½	7½	
		9250	5	7½	7½	7½	10	
		9750	7½	7½	7½	10	10	
		10,275	7½	7½	7½	10	10	
		10,900	7½	10	10	10	15	
		11,575	10	10	10	15	15	
175/65-75	3) 18" x 13"	11,575	5	5	7½	7½	7½	7½
		12,150	5	5	7½	7½	7½	
		12,850	5	7½	7½	7½	10	
		13,600	7½	7½	7½	10	10	
		14,500	7½	10	10	10	10	
		15,400	10	10	10	15	15	
		16,000	10	10	15	15	15	
		17,000	15	15	15	15	15	
		18,000	15	15	15	15	20	
		19,000	15	15	20	20	20	
		20,250	20	20	20	25	25	
85-100	2) 18" x 18"	7875	3	5	5	5	7½	7½
		8275	5	5	5	7½	7½	
		8775	5	5	7½	7½	7½	
		9250	5	7½	7½	7½	10	
		9750	7½	7½	7½	10	10	
		10,275	7½	7½	7½	10	10	
		10,900	7½	10	10	10	15	
		11,575	10	10	10	15	15	

**NOTES:**

1. The horsepower selections are based on system total external static pressure. To determine total external static pressure, add system duct loss plus all applicable accessory pressure drops listed below:

- A. Fresh Air Inlet Hood & Birdscreen .10" W.C.
- B. Motor Operated Inlet Damper .18" W.C.
- C. V-Bank Filter Section .25" W.C.

2. Select unit size and motor horsepower from above table.

**EXPLANATION OF MODEL NUMBERS:**

**DASH MODEL NUMBERS** – A dash in the model number indicates the BTU range on the heat exchanger.

Example: Model 25-35 has a heat exchanger rating of 250,000-350,000 BTU output.

**SLASH MODEL NUMBERS** – A slash in the model number indicates the use of a larger blower section with a smaller heat exchanger, normally used for low temperature applications. Example: Model 75/25-35 has a 75 size blower section, which offers airflow up to 8675 CFM, with a heat exchanger rating of 250,000-350,000 BTU output.

# Air Delivery Table

Heating Only Units								
TIR Model No.	Blowers	SCFM	Total External Static Pressure (W.C.)					
			¼"	½"	¾"	1"	1¼"	1½"
			HP	HP	HP	HP	HP	HP
175/85-100	3) 18" x 13"	11,575	5	5	7½	7½	7½	7½
		12,150	5	5	7½	7½	7½	10
		12,850	5	7½	7½	7½	10	10
		13,600	7½	7½	7½	10	10	10
		14,500	7½	10	10	10	10	15
		15,400	10	10	10	15	15	15
		16,000	10	10	15	15	15	15
		17,000	15	15	15	15	15	15
		18,000	15	15	15	15	20	20
		19,000	15	15	20	20	20	20
		20,250	20	20	20	25	25	25
250/85-100	3) 18" x 18"	18,500	7½	10	10	15	15	15
		19,500	10	10	15	15	15	15
		20,575	15	15	15	15	20	20
		21,775	15	15	15	20	20	20
		23,150	15	20	20	20	20	25
		24,350	20	20	20	25	25	25
		25,725	20	25	25	25	25	30
		27,725	25	25	30	30	30	40
		28,925	30	30	30	40	40	40
		125-175	3) 18" x 13"	11,575	5	5	7½	7½
12,150	5			5	7½	7½	7½	10
12,850	5			7½	7½	7½	10	10
13,600	7½			7½	7½	10	10	10
14,500	7½			10	10	10	10	15
15,400	10			10	10	15	15	15
16,000	10			10	15	15	15	15
17,000	15			15	15	15	15	15
18,000	15			15	15	15	20	20
19,000	15			15	20	20	20	20
20,250	20			20	20	25	25	25
250/125-175	3) 18" x 18"	18,500	7½	10	10	15	15	15
		19,500	10	10	15	15	15	15
		20,575	15	15	15	15	20	20
		21,775	15	15	15	20	20	20
		23,150	15	20	20	20	20	25
		24,350	20	20	20	25	25	25
		25,725	20	25	25	25	25	30
		27,725	25	25	30	30	30	40
		28,925	30	30	30	40	40	40
		275/125-175	3) 20" x 20"	25,450	10	15	15	15
26,800	15			15	15	20	20	20
28,300	15			15	20	20	20	25
29,950	20			20	20	25	25	25
31,825	20			25	25	25	30	30

**NOTES:**

1. The horsepower selections are based on system total external static pressure. To determine total external static pressure, add system duct loss plus all applicable accessory pressure drops listed below:

- A. Fresh Air Inlet Hood & Birdscreen .10" W.C.
- B. Motor Operated Inlet Damper .18" W.C.
- C. V-Bank Filter Section .25" W.C.

2. Select unit size and motor horsepower from above table.

**EXPLANATION OF MODEL NUMBERS:**

**DASH MODEL NUMBERS** – A dash in the model number indicates the BTU range on the heat exchanger.

Example: Model 25-35 has a heat exchanger rating of 250,000-350,000 BTU output.

**SLASH MODEL NUMBERS** – A slash in the model number indicates the use of a larger blower section with a smaller heat exchanger, normally used for low temperature applications. Example: Model 75/25-35 has a 75 size blower section, which offers airflow up to 8675 CFM, with a heat exchanger rating of 250,000-350,000 BTU output.



# Air Delivery Table

Heating Only Units									
TIR Model No.	Blowers	SCFM	Total External Static Pressure (W.C.)						
			¼"	½"	¾"	1"	1¼"	1½"	
			HP	HP	HP	HP	HP	HP	
200-250	3) 18" x 18"	18,500	7½	10	10	15	15	15	15
		19,500	10	10	15	15	15	15	15
		20,575	15	15	15	15	20	20	20
		21,775	15	15	15	20	20	20	20
		23,150	15	20	20	20	20	25	25
		24,350	20	20	20	25	25	25	25
		25,725	20	25	25	25	25	30	30
		27,725	25	25	30	30	30	40	40
		28,925	30	30	30	40	40	40	40
275/200-250	3) 20" x 20"	25,450	10	15	15	15	20	20	20
		26,800	15	15	15	20	20	20	20
		28,300	15	15	20	20	20	25	25
		29,950	20	20	20	25	25	25	25
		31,825	20	25	25	25	30	30	30
400/200-250	3) 22" x 22"	27,775	15	15	20	20	25	25	25
		29,250	15	20	20	25	25	30	30
		30,850	20	20	25	25	30	30	30
		32,500	20	25	25	30	30	30	30
		34,100	25	25	30	30	40	40	40
		36,000	30	30	40	40	40	40	40
		38,125	40	40	40	40	40	50	50
		40,500	40	40	50	50	50	50	50
		41,150	40	50	50	50	50	50	50
		43,575	50	50	50	60	60	60	60
46,300	60	60	60	60	75	75	75		
275	3) 20" x 20"	25,450	10	15	15	15	20	20	20
		26,800	15	15	15	20	20	20	20
		28,300	15	15	20	20	20	25	25
		29,950	20	20	20	25	25	25	25
		31,825	20	25	25	25	30	30	30
400/275	3) 22" x 22"	27,775	15	15	20	20	25	25	25
		29,250	15	20	20	25	25	30	30
		30,850	20	20	25	25	30	30	30
		32,500	20	25	25	30	30	30	30
		34,100	25	25	30	30	40	40	40
		36,000	30	30	40	40	40	40	40
		38,125	40	40	40	40	40	50	50
		40,500	40	40	50	50	50	50	50
		41,150	40	50	50	50	50	50	50
		43,575	50	50	50	60	60	60	60
46,300	60	60	60	60	75	75	75		
325-400	3) 22" x 22"	27,775	15	15	20	20	25	25	25
		29,250	15	20	20	25	25	30	30
		30,850	20	20	25	25	30	30	30
		32,500	20	25	25	30	30	30	30
		34,100	25	25	30	30	40	40	40
		36,000	30	30	40	40	40	40	40
		38,125	40	40	40	40	40	50	50
		40,500	40	40	50	50	50	50	50
		41,150	40	50	50	50	50	50	50
		43,575	50	50	50	60	60	60	60
46,300	60	60	60	60	75	75	75		

**NOTES:**

1. The horsepower selections are based on system total external static pressure. To determine total external static pressure, add system duct loss plus all applicable accessory pressure drops listed below:

- A. Fresh Air Inlet Hood & Birdscreen .10" W.C.
- B. Motor Operated Inlet Damper .18" W.C.
- C. V-Bank Filter Section .25" W.C.

2. Select unit size and motor horsepower from above table.

**EXPLANATION OF MODEL NUMBERS:**

**DASH MODEL NUMBERS** – A dash in the model number indicates the BTU range on the heat exchanger.

Example: Model 25-35 has a heat exchanger rating of 250,000-350,000 BTU output.

**SLASH MODEL NUMBERS** – A slash in the model number indicates the use of a larger blower section with a smaller heat exchanger, normally used for low temperature applications. Example: Model 75/25-35 has a 75 size blower section, which offers airflow up to 8675 CFM, with a heat exchanger rating of 250,000-350,000 BTU output.

# Dimensions

## TIR Models

C000523

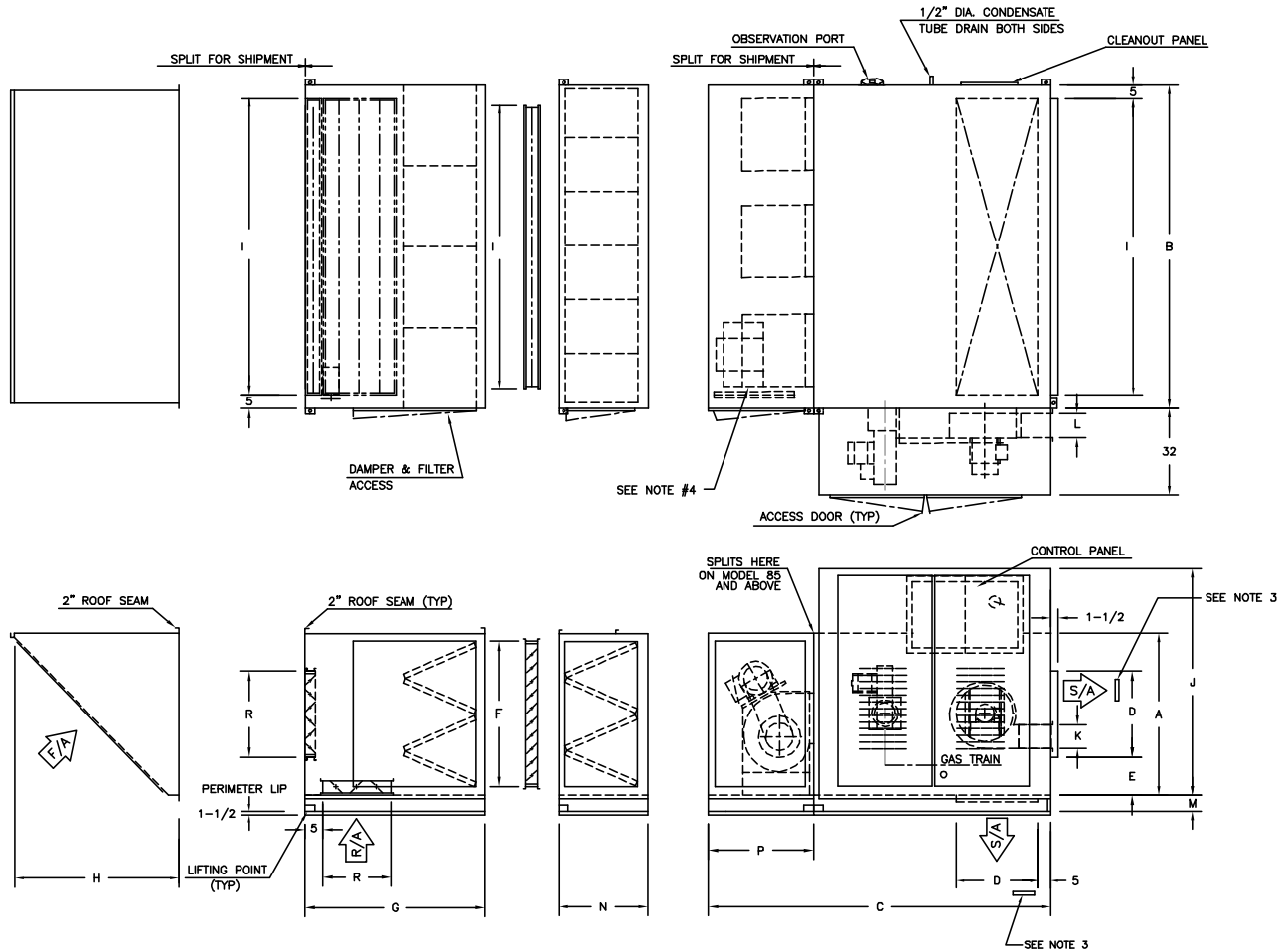

### NOTES:

1. \*Denotes an item shipped loose for installation by others.
2. This unit to be assembled and tested in the shop, then split as noted for shipping. Any field assembly required for installation of this equipment is the responsibility of the installation contractor.
3. Mount S/A discharge air sensor (3SEN) in duct a minimum of 3'0" from unit by others.
4. Models 25-35 through 85-100 will have two (2) blowers.  
Models 125-175 through 300-400 will have three (3) blowers.

TIR Model No.	DIMENSIONS																Filters Qty. Size
	A	B	C	D	E	F	G	H	I	J	K	L	M	N	P	R	
25-35	38	48	98	18	10	34	48	42	38	54	6¼	6⅝	4	23	—	18	4) 20 x 20 x 2
40-55	38	60	98	18	10	34	48	42	50	54	6¼	6⅝	4	23	—	18	6) 20 x 20 x 2
65-75	38	80	98	18	10	34	48	42	70	54	6¼	6⅝	4	23	—	18	8) 20 x 20 x 2
85-100	48	80	110	18	15	44	48	52	70	58	6¼	6⅝	4	23	42	18	12) 20 x 20 x 2
125-175	54	100	121	24	15	50	54	55	90	66	9	9⅝	6	23	42	24	15) 20 x 20 x 2
200-250	60	120	130	30	15	56	62	61	110	70	9	9⅝	6	25	42	30	24) 20 x 20 x 2
275	65	140	137	30	17½	61	62	66	130	75	10⅝	11⅞	6	25	45	30	28) 20 x 20 x 2
300-400	70	160	151	30	20	66	60	71	150	80	10⅝	11⅞	8	23	45	30	32) 20 x 20 x 2

# Dimensions

## TIR Roof Curb

C000525

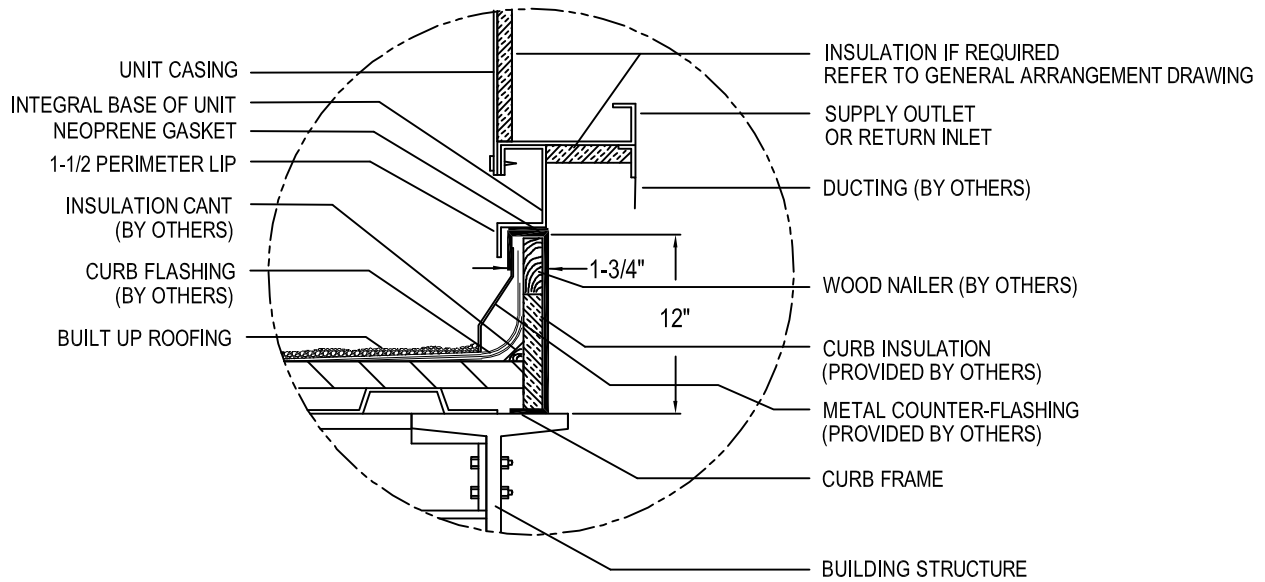
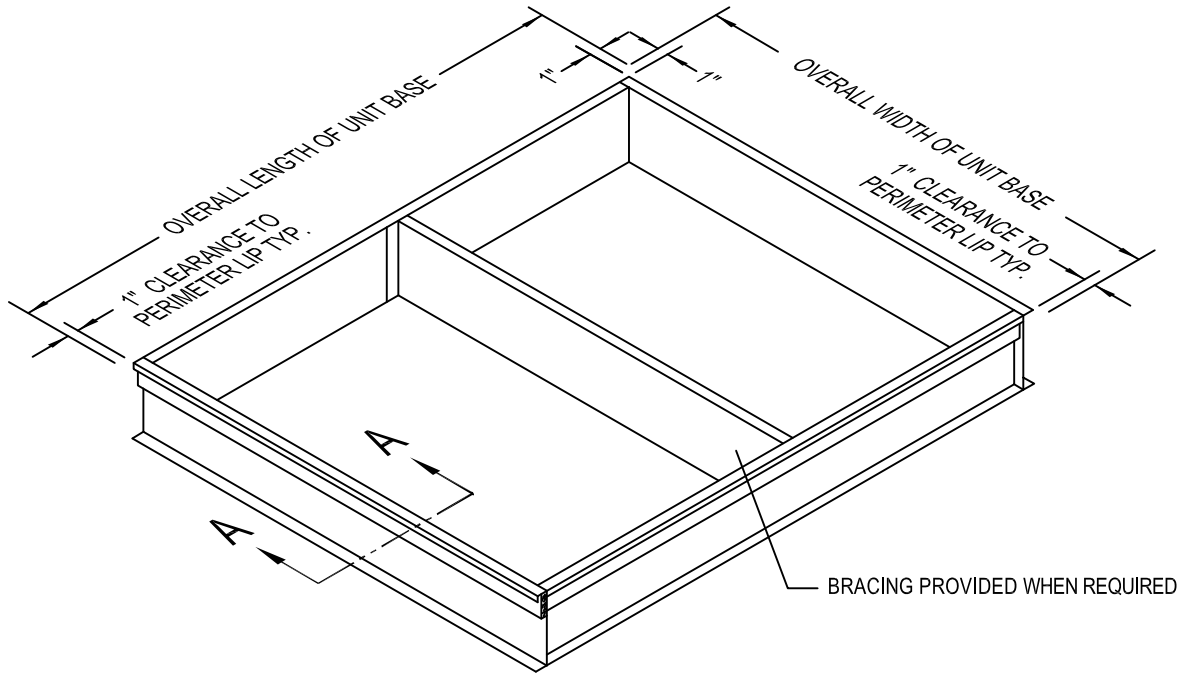

ROOF CURB DETAIL

# Air Delivery Table

Cooling Units								
TIR Model No.	Blowers	SCFM	Total External Static Pressure (W.C.)					
			¼"	½"	¾"	1"	1¼"	1½"
			HP	HP	HP	HP	HP	HP
25-35	2) 12" x 9"	2300	½	¾	1	1	1½	1½
		2450	½	¾	1	1	1½	1½
		2575	¾	¾	1	1	1½	1½
		2725	¾	1	1	1	1½	1½
		2900	¾	1	1	1½	1½	1½
		3250	¾	1	1	1½	1½	2
40-55	2) 12" x 12"	3700	¾	1	1½	1½	2	2
		3900	1	1	1½	1½	2	2
		4100	1	1½	1½	2	2	3
		4350	1	1½	1½	2	2	3
		4600	1½	1½	2	2	3	3
65-75	2) 15" x 15"	6000	1½	2	3	3	5	5
		6350	2	3	3	3	5	5
		6675	2	3	3	5	5	5
85-100	2) 18" x 18"	7875	3	5	5	5	7½	7½
		8275	5	5	5	7½	7½	7½
		8775	5	5	7½	7½	7½	10
		9250	5	7½	7½	7½	10	10
125-175	3) 18" x 13"	11,575	5	5	7½	7½	7½	7½
		12,150	5	5	7½	7½	7½	10
		12,850	5	7½	7½	7½	10	10
		13,600	7½	7½	7½	10	10	10
200-250	3) 18" x 18"	18,500	7½	10	10	15	15	15
300-400	3) 22" x 22"	27,775	15	15	20	20	25	25
		29,250	15	20	20	25	25	30
		30,850	20	20	25	25	30	30

**NOTES:**

1. The horsepower selections are based on system total external static pressure. To determine total external static pressure, add system duct loss plus all applicable accessory pressure drops listed below:

- A. Fresh Air Inlet Hood & Birdscreen .10" W.C.
- B. Motor Operated Inlet Damper .18" W.C.
- C. V-Bank Filter Section .25" W.C.
- D. Cooling Coil See page 14 or 15

2. Select unit size and motor horsepower from above table.

**EXPLANATION OF MODEL NUMBERS:**

DASH MODEL NUMBERS – A dash in the model number indicates the BTU range on the heat exchanger.

Example: Model 25-35 has a heat exchanger rating of 250,000-350,000 BTU output.

SLASH MODEL NUMBERS – A slash in the model number indicates the use of a larger blower section with a smaller heat exchanger, normally used for low temperature applications. Example: Model 75/25-35 has a 75 size blower section, which offers airflow up to 6675 CFM, with a heat exchanger rating of 250,000-350,000 BTU output.

Unit Weights (Approximate)							C000526
<p style="text-align: center;">PLAN VIEW</p>							
Model	Blower and Heat Exchanger Section	Inlet Hood	Inlet Damper	Combination V-Bank Filter Mixing Box	V-Bank Filter	Cooling Coil Section (with 6 Row Coil)	
25-35	2515	100	85	410	120	720	
40-55	2830	110	105	475	135	815	
65-75	3535	135	140	610	175	1015	
85-100	4400	275	175	705	225	1120	
125-175	5890	400	245	875	310	1455	
200-250	7305	510	340	1160	385	1695	
275	10,050	600	425	1435	405	NA	
300-400	12,800	690	545	1645	570	2885	

APPROXIMATE WEIGHT (LBS.)

# Dimensions

## TIR Models with Cooling Coil Section

C000524

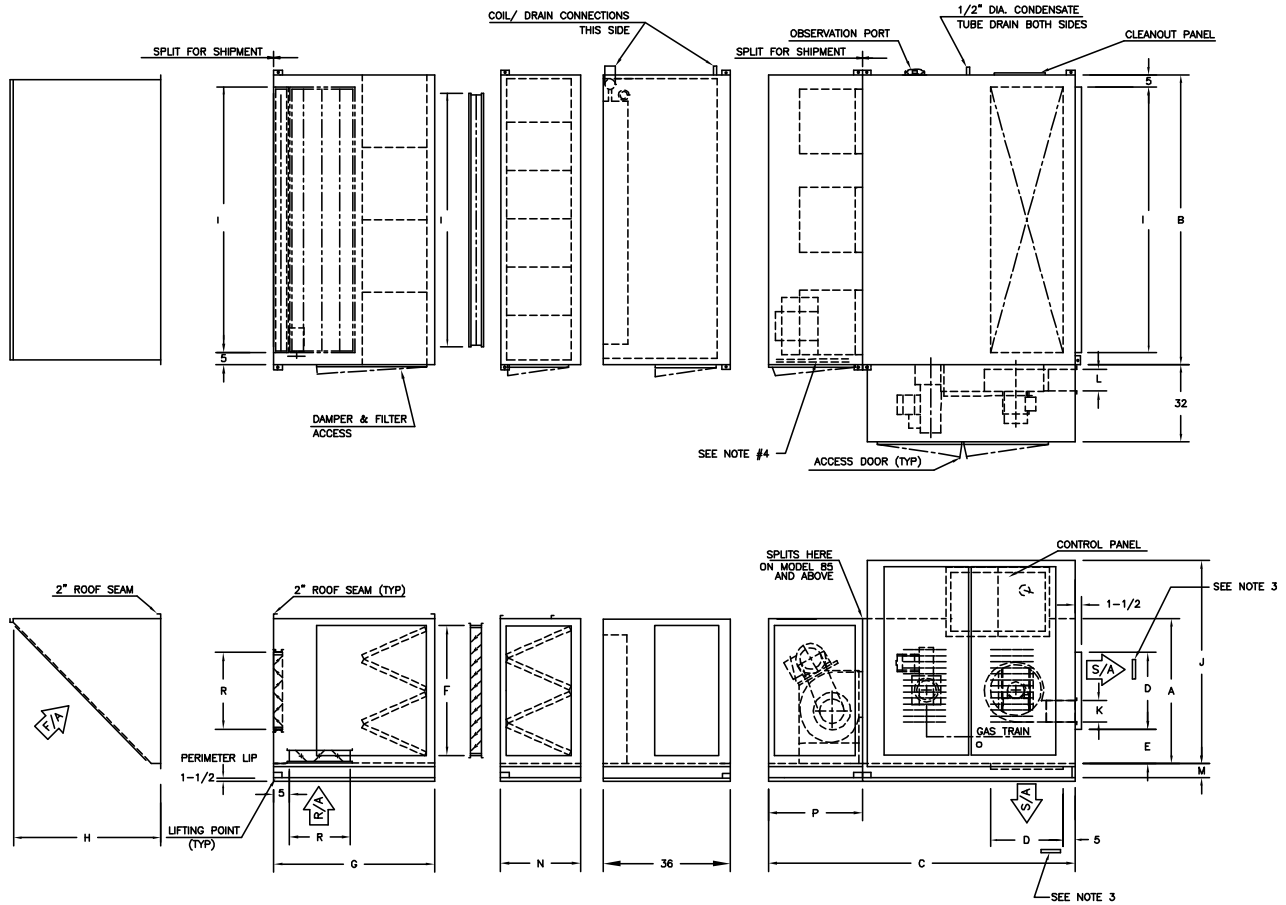

**NOTES:**

1. \*Denotes an item shipped loose for installation by others.
2. This unit to be assembled and tested in the shop, then split as noted for shipping. Any field assembly required for installation of this equipment is the responsibility of the installation contractor.
3. Mount S/A discharge air sensor (3SEN) in duct a minimum of 3'0" from unit by others.
4. Models 25-35 through 85-100 will have two (2) blowers.  
Models 125-175 through 300-400 will have three (3) blowers.

TIR Model No.	DIMENSIONS																Filters Qty. Size
	A	B	C	D	E	F	G	H	I	J	K	L	M	N	P	R	
25-35	38	48	98	18	10	34	48	42	38	54	6¼	6¾	4	23	—	18	4) 20 x 20 x 2
40-55	38	60	98	18	10	34	48	42	50	54	6¼	6¾	4	23	—	18	6) 20 x 20 x 2
65-75	38	80	98	18	10	34	48	42	70	54	6¼	6¾	4	23	—	18	8) 20 x 20 x 2
85-100	48	80	110	18	15	44	48	52	70	58	6¼	6¾	4	23	42	18	12) 20 x 20 x 2
125-175	54	100	121	24	15	50	54	55	90	66	9	9¾	6	23	42	24	15) 20 x 20 x 2
200-250	60	120	130	30	15	56	62	67	110	70	9	9¾	6	25	42	30	24) 20 x 20 x 2
300-400	70	160	151	30	20	66	60	71	150	80	10¾	11¼	8	23	45	30	32) 20 x 20 x 2

# Performance Table

DX Coil Data									
TIR Model No.	Coil Face Area Sq.Ft. (FH x FL)	SCFM	Face Velocity (FPM)	4 Row DX					
				80/67° EAT			95/77° EAT		
				Total MBH	LAT	Air P.D.	Total MBH	LAT	Air P.D.
25-35	6.46 1 (30" x 31")	2,300	356	63.21	60.0/58.6	0.26	142.64	62.1/60.4	0.26
		2,450	379	66.67	60.2/58.7	0.29	149.26	62.5/60.8	0.29
		2,575	399	69.25	60.4/58.8	0.31	154.65	62.9/61.1	0.31
		2,725	422	72.69	60.5/58.9	0.34	160.94	63.3/61.4	0.34
		2,900	449	76.37	60.7/59.0	0.38	154.88	65.2/63.1	0.38
		3,250	503	83.41	61.0/59.2	0.46	168.37	65.9/63.6	0.46
40-55	8.96 1 (30" x 43")	3,700	413	109.58	59.4/57.9	0.33	216.54	63.4/61.5	0.33
		3,900	435	113.89	59.6/58.0	0.36	224.88	63.8/61.8	0.36
		4,100	458	118.18	59.8/58.1	0.39	233.00	64.1/62.1	0.39
		4,350	486	123.86	60.0/58.3	0.43	242.79	64.5/62.4	0.43
		4,600	513	128.99	60.2/58.4	0.48	252.29	64.9/62.7	0.48
		6,000	457	194.40	58.6/56.9	0.39	352.62	63.5/61.5	0.39
65-75	13.13 1 (30" x 63")	6,350	484	168.64	60.7/58.9	0.43	366.65	63.9/61.8	0.43
		6,675	509	174.96	60.9/59.0	0.47	379.28	64.3/62.1	0.47
		7,875	444	259.22	58.4/56.7	0.37	475.31	62.9/61.0	0.37
85-100	17.72 1 (40 1/2" x 63")	8,275	467	268.31	58.6/56.9	0.41	468.75	64.2/62.1	0.41
		8,775	495	278.57	58.9/57.1	0.45	488.18	64.6/62.4	0.45
		9,250	522	289.02	59.1/57.3	0.49	506.32	65.0/62.7	0.49
		11,575	432	332.20	59.8/58.2	0.36	703.44	62.7/60.8	0.36
125-175	26.80 1 (46 1/2" x 83")	12,150	453	344.53	60.0/58.3	0.39	727.51	63.1/61.1	0.39
		12,850	479	360.11	60.2/58.4	0.42	755.96	63.5/61.4	0.42
		13,600	507	375.70	60.4/58.5	0.47	785.80	63.9/61.8	0.47
		18,500	523	575.78	59.2/57.4	0.49	1066.07	64.0/61.8	0.49
200-250	36.48 2 (25 1/2" x 103")	27,775	466	865.59	59.0/57.3	0.40	1587.81	64.0/62.0	0.40
		29,250	491	898.43	59.3/57.5	0.44	1649.25	64.4/62.2	0.44
		30,850	518	932.95	59.5/57.7	0.48	1711.84	64.7/62.5	0.48
TIR Model No.	Coil Face Area Sq.Ft.	SCFM	Face Velocity (FPM)	6 Row DX					
				80/67° EAT			95/77° EAT		
				Total MBH	LAT	Air P.D.	Total MBH	LAT	Air P.D.
25-35	6.46 1 (30" x 31")	2,300	356	84.99	55.9/55.3	0.39	173.22	56.5/55.9	0.39
		2,450	379	89.83	56.0/55.4	0.43	182.10	56.9/56.3	0.43
		2,575	399	93.75	56.1/55.5	0.47	162.36	60.8/60.1	0.47
		2,725	422	98.27	56.3/55.6	0.51	170.38	61.1/60.3	0.51
		2,900	449	103.30	56.5/55.8	0.57	179.50	61.3/60.5	0.57
		3,250	503	113.27	56.8/56.0	0.69	196.87	61.8/60.9	0.69
40-55	8.96 1 (30" x 43")	3,700	413	153.35	54.3/53.6	0.50	238.66	60.4/59.6	0.50
		3,900	435	159.56	54.5/53.8	0.54	253.88	60.2/59.4	0.54
		4,100	458	131.69	57.8/57.0	0.59	264.57	60.4/59.6	0.59
		4,350	486	138.37	57.9/57.1	0.65	277.64	60.7/59.8	0.65
		4,600	513	145.48	58.0/57.2	0.71	290.39	61.0/60.1	0.71
		6,000	457	218.44	56.2/55.5	0.59	376.79	61.0/60.2	0.59
65-75	13.13 1 (30" x 63")	6,350	484	228.81	56.4/55.6	0.65	394.59	61.3/60.4	0.65
		6,675	509	238.11	56.6/55.8	0.70	418.73	61.1/60.2	0.70
		7,875	444	288.04	56.1/55.4	0.56	510.22	60.3/59.5	0.56
85-100	17.72 1 (40 1/2" x 63")	8,275	467	300.12	56.3/55.5	0.61	529.86	60.6/59.8	0.61
		8,775	495	314.72	56.5/55.7	0.67	557.97	60.8/59.9	0.67
		9,250	522	328.14	56.6/55.8	0.73	581.03	61.1/60.2	0.73
		11,575	432	479.40	54.3/53.7	0.53	834.58	57.8/57.0	0.53
125-175	26.80 1 (46 1/2" x 83")	12,150	453	497.57	54.5/53.8	0.58	867.48	58.1/57.3	0.58
		12,850	479	519.11	54.8/54.0	0.64	906.13	58.4/57.6	0.64
		13,600	507	541.52	55.0/54.3	0.70	946.43	58.8/57.9	0.70
		18,500	523	639.06	55.9/55.1	0.73	1255.19	59.4/58.5	0.73
200-250	36.48 2 (25 1/2" x 103")	27,775	466	1084.56	55.3/54.5	0.61	1989.94	58.0/57.2	0.61
		29,250	491	1129.02	55.5/54.7	0.66	2071.23	58.3/57.5	0.66
		30,850	518	1176.81	55.7/54.9	0.72	2158.29	58.7/57.8	0.72
300-400	59.58 2 (30" x 143")	27,775	466	1084.56	55.3/54.5	0.61	1989.94	58.0/57.2	0.61
		29,250	491	1129.02	55.5/54.7	0.66	2071.23	58.3/57.5	0.66
		30,850	518	1176.81	55.7/54.9	0.72	2158.29	58.7/57.8	0.72

**NOTE:** Coil capacity based on R410A with 45° suction temperature. All coils have 5/8" tubes and 8 FPI.

# Performance Table

CW Coil Data													
TIR Model No.	Coil Face Area Sq.Ft. (FH x FL)	SCFM	Face Velocity (FPM)	4 Row CW									
				80/67° EAT					95/77° EAT				
				Total MBH	LAT	Air P.D.	GPM	FPD (ft)	Total MBH	LAT	Air P.D.	GPM	FPD (ft)
25-35	6.46 1 (30" x 31")	2,300	356	70.36	59.0/57.5	0.26	14.0	1.39	140.43	62.4/60.7	0.26	28.0	4.71
		2,450	379	73.23	59.3/57.8	0.29	14.6	1.50	146.53	62.9/61.1	0.29	29.3	5.08
		2,575	399	75.55	59.5/58.0	0.31	15.1	1.58	151.28	63.3/61.5	0.31	30.2	5.38
		2,725	422	78.25	59.8/58.2	0.34	15.6	1.68	156.79	63.8/61.9	0.34	31.3	5.73
		2,900	449	81.29	60.1/58.4	0.38	16.2	1.80	161.06	64.5/62.5	0.38	32.2	6.00
		3,250	503	87.12	60.6/58.8	0.46	17.4	2.03	172.16	65.5/63.3	0.46	34.4	6.75
40-55	8.96 1 (30" x 43")	3,700	413	116.78	58.8/57.2	0.33	23.3	3.84	208.21	64.2/62.2	0.33	41.6	3.91
		3,900	435	120.68	59.0/57.4	0.36	24.1	4.06	214.63	64.6/62.6	0.36	42.9	4.12
		4,100	458	124.46	59.3/57.6	0.39	24.9	4.29	221.43	65.0/62.9	0.39	44.2	4.36
		4,350	486	129.03	59.6/57.9	0.43	25.8	4.57	229.58	65.5/63.3	0.43	45.8	4.65
		4,600	513	133.44	59.9/58.1	0.48	26.6	4.85	236.48	66.0/63.7	0.48	47.2	4.90
		6,000	457	196.43	58.4/56.8	0.39	39.2	11.33	332.10	64.6/62.5	0.39	66.3	5.15
65-75	13.13 1 (30" x 63")	6,350	484	203.45	58.8/57.0	0.43	40.6	12.05	342.58	65.1/63.0	0.43	68.4	5.44
		6,675	509	209.75	59.0/57.2	0.47	41.9	12.71	353.44	65.5/63.3	0.47	70.6	5.75
		7,875	444	222.69	60.0/58.3	0.37	44.5	1.49	440.69	64.4/62.3	0.37	88.0	4.99
85-100	17.72 1 (40 1/2" x 63")	8,275	467	229.49	60.2/58.5	0.41	45.8	1.57	454.13	64.8/62.7	0.41	90.7	5.27
		8,775	495	237.90	60.5/58.7	0.45	47.5	1.67	469.33	65.3/63.1	0.45	93.7	5.58
		9,250	522	245.45	60.8/58.9	0.49	49.0	1.77	483.16	65.8/63.5	0.49	96.5	5.88
		11,575	432	356.28	59.1/57.5	0.36	71.1	3.03	633.37	64.7/62.7	0.36	126.5	3.15
125-175	26.80 1 (46 1/2" x 83")	12,150	453	367.10	59.3/57.7	0.39	73.3	3.19	652.85	65.1/63.0	0.39	130.4	3.33
		12,850	479	379.86	59.6/57.9	0.42	75.9	3.39	675.60	65.6/63.4	0.42	134.9	3.54
		13,600	507	393.07	59.9/58.1	0.47	78.5	3.60	699.40	66.0/63.7	0.47	139.7	3.76
		200-250	36.48 2 (25 1/2" x 103")	18,500	523	554.30	59.6/57.7	0.49	110.7	6.59	987.66	65.4/63.1	0.49
300-400	59.58 2 (30" x 143")	27,775	466	856.58	59.1/57.4	0.40	171.1	4.44	1582.37	64.1/62.0	0.40	316.0	6.57
		29,250	491	884.04	59.4/57.7	0.44	176.5	4.70	1635.38	64.5/62.4	0.44	326.6	6.97
		30,850	518	912.89	59.7/57.9	0.48	182.3	4.97	1666.46	65.2/62.9	0.48	332.8	7.21

TIR Model No.	Coil Face Area Sq.Ft.	SCFM	Face Velocity (FPM)	6 Row CW									
				80/67° EAT					95/77° EAT				
				Total MBH	LAT	Air P.D.	GPM	FPD (ft)	Total MBH	LAT	Air P.D.	GPM	FPD (ft)
25-35	6.46 1 (30" x 31")	2,300	356	95.66	54.2/53.6	0.39	19.1	3.26	179.47	55.5/54.9	0.39	35.8	9.83
		2,450	379	99.94	54.5/53.9	0.43	20.0	3.52	188.46	56.0/55.3	0.43	37.6	10.71
		2,575	399	103.62	54.7/54.1	0.47	20.7	3.75	195.80	56.3/55.7	0.47	39.1	11.45
		2,725	422	107.98	55.0/54.3	0.51	21.6	4.03	203.99	56.8/56.1	0.51	40.7	12.30
		2,900	449	112.71	55.3/54.6	0.57	22.5	4.35	213.35	57.3/56.5	0.57	42.6	13.31
		3,250	503	121.43	55.9/55.1	0.69	24.2	4.95	231.65	58.2/57.3	0.69	46.3	15.38
40-55	8.96 1 (30" x 43")	3,700	413	145.20	55.1/54.5	0.50	29.0	2.76	261.10	58.3/57.6	0.50	52.1	3.80
		3,900	435	150.56	55.4/54.7	0.54	30.1	2.94	270.17	58.8/58.0	0.54	53.9	4.03
		4,100	458	155.81	55.6/54.9	0.59	31.1	3.12	280.33	59.1/58.3	0.59	56.0	4.30
		4,350	486	162.21	55.9/55.2	0.65	32.4	3.35	292.57	59.6/58.7	0.65	58.4	4.64
		4,600	513	167.95	56.3/55.5	0.71	33.5	3.56	303.84	60.0/59.1	0.71	60.7	4.96
		6,000	457	244.90	54.6/53.9	0.59	48.9	8.19	440.24	57.4/56.6	0.59	87.9	11.16
65-75	13.13 1 (30" x 63")	6,350	484	254.69	54.9/54.1	0.65	50.9	8.77	458.98	57.8/57.0	0.65	91.7	12.01
		6,675	509	263.55	55.2/54.4	0.70	52.6	9.32	475.26	58.2/57.4	0.70	94.9	12.77
		7,875	444	324.22	54.4/53.8	0.56	64.7	7.92	582.04	57.2/56.4	0.56	116.2	10.76
85-100	17.72 1 (40 1/2" x 63")	8,275	467	335.55	54.7/54.0	0.61	67.0	8.41	604.64	57.5/56.7	0.61	120.7	11.51
		8,775	495	349.39	55.0/54.3	0.67	69.8	9.02	629.79	58.0/57.2	0.67	125.8	12.36
		9,250	522	361.16	55.3/54.5	0.73	72.1	9.56	653.44	58.4/57.5	0.73	130.5	13.19
		11,575	432	498.56	53.7/53.0	0.53	99.6	15.26	846.81	57.4/56.7	0.53	169.1	6.83
125-175	26.80 1 (46 1/2" x 83")	12,150	453	517.15	53.9/53.2	0.58	103.3	16.27	878.16	57.8/57.0	0.58	175.4	7.29
		12,850	479	537.57	54.2/53.5	0.64	107.3	17.41	914.14	58.2/57.4	0.64	182.5	7.82
		13,600	507	559.01	54.5/53.8	0.70	111.6	18.64	941.39	58.9/58.0	0.70	188.0	8.24
		200-250	36.48 2 (25 1/2" x 103")	18,500	523	746.34	54.8/54.1	0.73	149.0	15.06	1320.71	58.2/57.3	0.73
300-400	59.58 2 (30" x 143")	27,775	466	1148.59	54.4/53.7	0.61	229.4	9.98	2004.45	57.8/57.0	0.61	400.3	7.55
		29,250	491	1086.32	56.0/55.2	0.66	216.9	2.55	2077.64	58.3/57.4	0.66	414.9	8.04
		30,850	518	1122.85	56.3/55.5	0.72	224.2	2.71	2155.67	58.7/57.8	0.72	430.5	8.59

**NOTE:** Coil capacity based on 45° EWT and 55° LWT. All coils have 5/8" tubes and 8 FPI.

# Electrical Data

Amp Draw Table										
Item A										
SOURCE	AMPS (2)	MOTOR HORSEPOWER								
		1/2	3/4	1	1 1/2	2	3	5	7 1/2	10
Blower Motor	208V 3 PH	2.4	3.5	4.6	6.6	7.5	10.6	16.7	24.2	30.8
	230V 3 PH	2.2	3.2	4.2	6.0	6.8	9.6	15.3	22.0	28.8
	460V 3 PH	1.1	1.6	2.1	3.0	3.4	4.8	7.6	11.0	14.4
	575V 3 PH	0.9	1.3	1.7	2.4	2.7	3.9	6.1	9.0	11.5
SOURCE	AMPS (2)	MOTOR HORSEPOWER								
		15	20	25	30	40	50	60	75	
Blower Motor	208V 3 PH	46.2	59.4	74.8	88.0	NA	NA	NA	NA	NA
	230V 3 PH	42.0	54.0	68.0	80.0	104	130	154	NA	NA
	460V 3 PH	21.0	27.0	34.0	40.0	52.0	65.0	77.0	96.0	96.0
	575V 3 PH	17.0	22.0	27.0	32.0	41.0	52.0	62.0	77.0	77.0
Item B										
SOURCE	AMPS (3)	BURNER SIZE								
		25	35	40	50	55	65			
Burner Motor HP (4)		1/4	1/4	1/4	1/4	1/4	1/3			
Induced Draft Fan Motor HP		1/3	1/3	1/3	1/3	1/3	1/2			
Amp Draw for Burner Motor, Induced Draft Motor, and Control Transformer	208V 3 PH	7.2	7.2	7.2	7.2	7.2	9.6			
	230V 3 PH	6.5	6.5	6.5	6.5	6.5	8.7			
	460V 3 PH	3.3	3.3	3.3	3.3	3.3	4.3			
	575V 3 PH	2.6	2.6	2.6	2.6	2.6	3.5			
SOURCE	AMPS (3)	BURNER SIZE								
		75	85	100	125	150	175			
Burner Motor HP (4)		1/3	1/3	1/3	1/3	1/3	1/3			
Induced Draft Fan Motor HP		1/2	1/2	1/2	2	2	2			
Amp Draw for Burner Motor, Induced Draft Motor, and Control Transformer	208V 3 PH	9.6	9.6	9.6	12.3	12.3	12.3			
	230V 3 PH	8.7	8.7	8.7	11.1	11.1	11.1			
	460V 3 PH	4.3	4.3	4.3	5.6	5.6	5.6			
	575V 3 PH	3.5	3.5	3.5	4.4	4.4	4.4			
SOURCE	AMPS (3)	BURNER SIZE								
		200	250	275	300	350	400			
Burner Motor HP (4)		3/4	1 1/2	1 1/2	1 1/2	3	3			
Induced Draft Fan Motor HP		2	5	5	5	5	5			
Amp Draw for Burner Motor, Induced Draft Motor, and Control Transformer	208V 3 PH	13.4	25.7	25.7	25.7	29.7	29.7			
	230V 3 PH	12.2	23.5	23.5	23.5	27.1	27.1			
	460V 3 PH	6.1	11.7	11.7	11.7	13.5	13.5			
	575V 3 PH	4.9	9.4	9.4	9.4	10.9	10.9			

NOTES: 1) NA = Not Available

- 2) Motor amps are based on 2011 edition of NEC.
- 3) Control circuit amps are based on standard controls.
- 4) Standard PowerFlame gas burner.

### Steps to Size Optional Disconnect Switch:

1. Find Blower Motor HP from tables on pages 6 -9 or page 12.
2. Find amp draw for Blower Motor HP from chart in Item A above.
3. Determine proper burner size required.
4. Find amps for Burner Motor, Induced Draft Motor, and Control Transformer from chart in Item B above.
5. Add amps from steps 2, and 4, then multiply by 1.25.



# Gas Piping Layout

## Schematic Component Diagrams

C000528

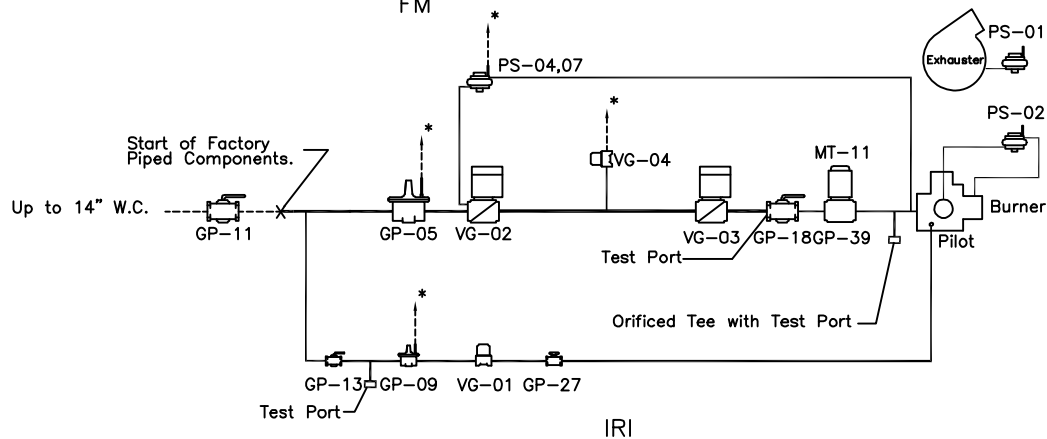
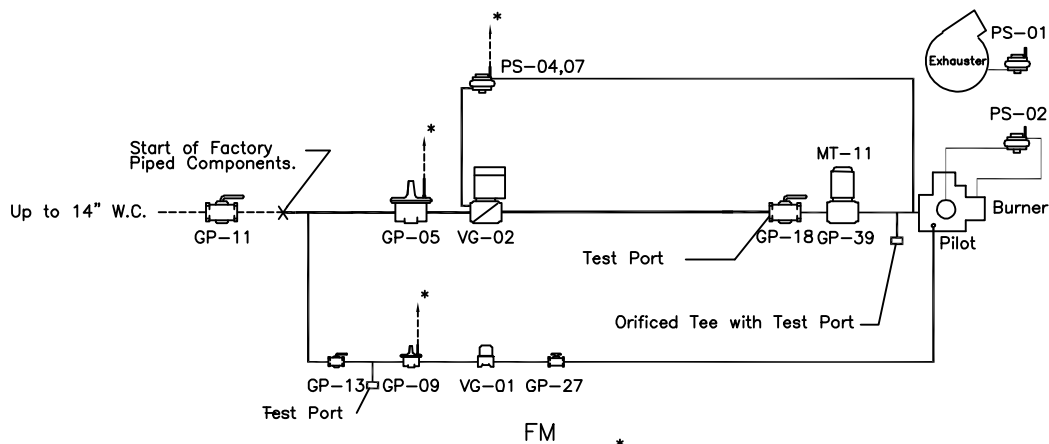
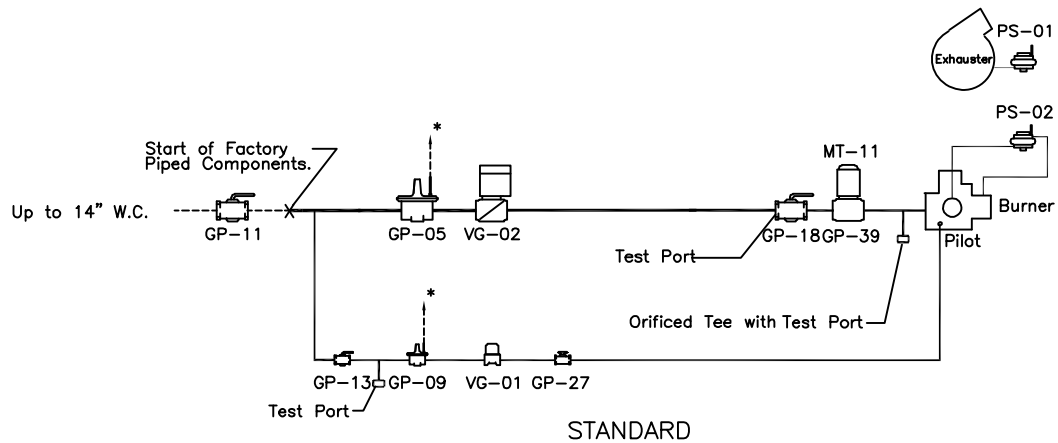

### COMPONENT IDENTIFICATION

GP-05 MAIN GAS PRESSURE REGULATOR  
 GP-09 PILOT GAS PRESSURE REGULATOR  
 GP-11 MAIN GAS SHUT-OFF VALVE  
 (SHIPPED LOOSE)  
 GP-13 PILOT GAS SHUT-OFF VALVE  
 GP-18 AUXILIARY GAS SHUT-OFF VALVE  
 GP-27 ORIFICED NEEDLE VALVE  
 GP-39 BUTTERFLY VALVE  
 (MODULATING BURNERS ONLY)

MT-11 BUTTERFLY VALVE OPERATOR  
 (MODULATING BURNERS ONLY)  
 PS-01 DRAFT PROVING SWITCH  
 PS-02 BURNER AIR FLOW SWITCH  
 PS-04 LOW GAS PRESSURE SWITCH  
 PS-07 HIGH GAS PRESSURE SWITCH  
 VG-01 PILOT GAS VALVE  
 VG-02 MAIN GAS VALVE  
 VG-03 AUXILIARY GAS VALVE  
 VG-04 N/O VENT VALVE

### NOTES:

1. Vent limiting devices provided wherever possible, when venting is required \* the venting to outside is by others on indoor units and furnished by factory on outdoor units.
2. All models require 7" W.C. minimum inlet pressure. Contact factory for inlet pressures below this minimum.
3. Standard manifold meets FM requirements for units less than or equal to 2000 MBH output for ETL listed units.
4. Standard manifold meets IRI requirements for ETL listed units.

# : Guide Specifications



Base Bid Temprite Model TIR \_\_\_\_\_ indirect fired heating and make-up air unit(s) designed for rooftop outdoor application. The unit shall be factory fabricated, assembled, wired and tested prior to shipment in accordance with the specification and equipment schedule. The unit will include all components herein and as shown on the drawings. Alternate equipment, equal in design, construction, performance and capacity to unit(s) specified, must be shown with price deduct/add, if any. Approval of alternate equipment will be subject to review of shop drawings. The unit shall be capable of delivering \_\_\_\_\_ SCFM at \_\_\_\_\_ ESP using a \_\_\_\_\_ horsepower (ODP) (TEFC) motor operating on (208)(230)(460)/3/60. The unit shall be ETL listed.

## CASING

The unit casing is to be panel construction from heavy gauge galvanized steel, suitably reinforced to ensure rigidity. All panels shall be factory sealed with caulking between mating panels. The casing enclosing the heat exchanger shall be of double wall construction with a galvanized steel inner wall serving as a radiation shield. Radiation and transmission losses shall not exceed 1½% of the rated output. This section shall be insulated with 1", 1½ lb. density insulation.

The unit shall have a weatherproof enclosure which is the full height of the unit. The enclosure will be complete with hinged access doors, fasteners and handles.

When split for shipping, the units splits will be framed with heavy structural angle to form flanges with drilled notch holes at 12" maximum spacing. Factory provided ½" thick gaskets for all flanges at all shipping splits. Will be shipped loose for field assembly.

Hinged access doors with cadmium plated piano type hinges shall be supplied to allow physical entry to all sections requiring inspections and periodic maintenance. Access doors shall be complete with 1" thick insulation, interior metal liner, fasteners, and handles.

The unit shall have an integral milled channel base complete with lifting lugs.

## BLOWER SECTION

Each unit shall be supplied with multiple centrifugal forward curve, DWDI blowers rated in accordance with AMCA standards. The blowers are to be mounted on a heavy duty, turned and ground and polished solid steel shaft designed for a maximum operating speed not to exceed 75% of its first critical speed.

The bearings are to be of the heavy-duty industrial pre-lubricated, self aligning type.

Drives shall have a capacity 25% greater than the motor horsepower. The motor sheave shall be of the adjustable pitch type for motors up to 7½ H.P.

The fan motor shall be mounted on an adjustable base and wired in flexible conduit to the control panel in the factory. The fan wheel, shaft, drives, and motor assembly shall be vibration balanced as a complete assembly in the factory.

## INDIRECT FIRED SECTION

The entire primary heat transfer surface and header shall be of 400 series stainless steel; the secondary heat transfer surface shall be (mild steel) (400 series stainless steel).

The heat exchanger design shall permit unrestricted lateral and peripheral expansion during the heating and cooling cycle. The flue gas travel shall be of four-pass design, with no internal baffles. The surface temperature of the heat exchanger shall not exceed 75% of its scaling temperature when operating at rated capacity. The heat exchanger shall be rated at a minimum of 80% efficiency at rated output. A pressure relief door complete with an observation window to view the complete flame and pilot shall be provided.

## DIRECT DRIVE INDUCED DRAFT FAN

An integrally mounted, heavy duty, non-clogging radial blade induced draft fan complete with direct drive motor shall be provided. The induced draft fan shall be adequately sized to insure proper draft conditions when operating at rated capacity and equipped with a "T" vent and manual damper complete with locking quadrant to ensure proper draft and extended heat exchanger performance.



### BURNER

The gas burner shall be of the power type, complete with integral combustion air blower and motor, combustion air proving switch, and removable pilot assembly. The combustion air damper shall be interlocked with the gas control valve to insure a proper gas/air mixture throughout the complete range of operation. Burner and controls shall be capable of delivering \_\_\_\_\_ MBH output firing on (natural gas) (propane) at an inlet pressure of \_\_\_\_\_ (inches water column) (PSIG) and in accordance with (manufacturer's standard) (FM) (IRI) requirements. Burner and controls shall be arranged for (High/Low/Off) (Full Modulation with low fire start and up to a 10:1 turndown ratio). The factory wired and piped valve train shall be mounted inside the unit weatherproof enclosure and be complete with:

- low pressure appliance regulator
- motorized gas control valve
- main manual test firing shut-off valve
- pilot manual shut-off valve
- pilot pressure regulator
- pilot automatic shut-off valve
- pilot manual test firing shut-off valve

### ELECTRICAL CONTROLS

A NEMA 1 control panel complete with hinged access door shall be mounted inside the weatherproof enclosure. All control components are to be labeled and individually wired to a numbered terminal strip to aid in servicing. All wiring shall be color coded and number tagged at each end to match the control diagram supplied. Full operating and maintenance instructions shall accompany each unit. All wiring between the controls and valves shall be run in flexible conduit. All electrical components shall bear the U.L. label. The control system shall include but not be limited to the following components required for automatic operation:

- control circuit transformer
- fan motor starters, overloads and sub-circuit fuses
- control circuit fuses
- control relays
- electronic flame relay complete with alarm contacts
- induced draft fan air proving differential switch
- high limit switch
- automatic/manual fan switch
- heavy duty ignition transformer

### OPTIONAL EQUIPMENT & CONTROLS

1. Motorized inlet air shut-off damper with a 16 gauge galvanized steel frame. Blades shall be rolled formed, triple V-groove 16 gauge galvanized steel, maximum 6" wide. Axles shall be 1/2" plated steel. The damper and damper motor shall be mounted inside the unit casing.
2. V-Bank filter section with nominal 2" thick (throwaway) (pleated) (cleanable) filters.
3. Combination filter/mixing section with nominal 2" thick (throwaway) (pleated) (cleanable) filters and motorized mixing dampers with a 16 gauge galvanized steel frame. Blades shall be rolled formed, triple V-groove 16 gauge galvanized steel, maximum 6" wide. Axles shall be 1/2" plated steel. The damper and damper motor shall be mounted inside the unit casing.
4. Cooling coil section complete with (Chilled Water) (DX) coil(s) with copper tubes, aluminum fins and galvanized steel casing. Headers to be non-ferrous with vents, drains and suitable for 200 psi working pressure. Maximum air velocity across the face of the coil shall not exceed 525 fpm. Cooling coil section shall have insulated casing and be a minimum of 36" deep in direction of airflow and located downstream of the filters and upstream of the fan section. Coils to slide into unit through a removable end panel. Provide 304 stainless steel drain pan under the cooling coil and downstream of the coil to collect all condensation. Provide a minimum of two drain pans where cooling coils are stacked complete with drain pipe between pans.
5. Inlet hood and birdscreen.
6. Perimeter roof curb.
7. Insulated (blower section) (filter section) (filter/mixing section).
8. Extended lube lines.
9. Internal blower/motor isolation.
10. Mild weather shutdown.
11. Clogged filter switch and indicating light.
12. Disconnect switch.
13. Painted galvanized casing.
14. High gas pressure regulator (shipped loose for inlet pressures over 1/2 PSIG).
15. Circuit analyzer.
16. Remote control panel.
17. Night set back thermostat.
18. 7 day time clock.

•  
•  
•  
•  
•  
•  
•

**TEMPRITE®**  
INDUSTRIES



## Efficient Indirect Fired Heating Systems

### Choose Temprite Indirect Gas Fired Systems

- Heat large spaces or warehouses without products of combustion in the supply air
- Mount units outdoors on the roof
- Low operating and maintenance costs
- Simple, inexpensive installation
- Temprite, a leader in research, engineering, and customer service since 1963

Temprite

[www.tempriteheating.com](http://www.tempriteheating.com)

4830 Transport Drive Dallas TX 75247

Telephone 214.638.6010