

# Temprite Air Turnover Systems

## Technical Guide for:

- **TAP** Standard Gas Heat Air Turnover
- **TAS** Non Gas Heat "Slave" Unit
- **TAC** Standard Cooling Only Air Turnover with Prop Fans
- **TAA** Standard Cooling Coil Plus Optional Gas Heat
- **TAJ** Standard Gas Heat With Cooling Coil Option For Small Buildings

Temprite

Keeps You

Warm

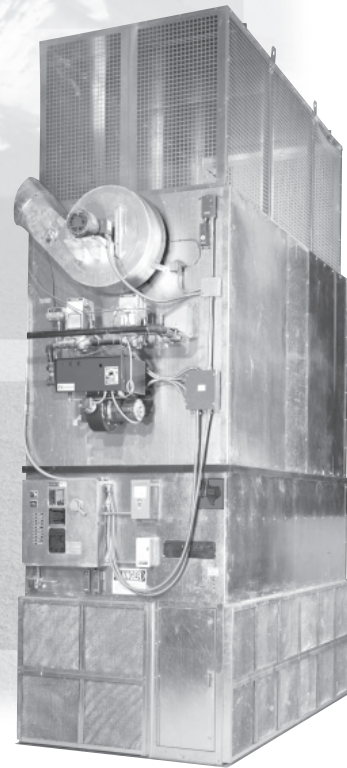

# : Air Turnover System : Application Guide



In the business of commercial warehouse and distribution, efficient and low-cost heating and cooling is essential. Temprite keeps you warm for less.

Since 1963, Temprite has been providing cost-effective, reliable heating solutions. Our Air Turnover System brings warm air down to your work environment for less than the operation and maintenance costs of unit heaters, radiant panels or overhead heating systems.

This Application Guide will help you choose a Temprite Air Turnover System to provide efficient, cost-effective heating and cooling for your warehouse or distribution operation. The Guide covers:

- Heating Needs — Identify heating needs for your specific facilities.
- Technical Specifications — Configure the right system components (e.g., motors, drive, filter, options, etc.) to meet your needs.
  - Model TAP – Standard Indirect Fired Air Turnover
  - Model TAS – “Slave” Unit, without Gas Heat
  - Model TAC – Standard Cooling Only Air Turnover with Prop Fans
  - Model TAA – Standard Cooling Air Turnover plus Optional Indirect Fired Gas Heat
  - Model TAJ – Smaller Indirect Fired Air Turnover with Optional Cooling Coil  
(TAJ unit not approved for installations in Canada)
- Installation Information — Plan details of on-site installation.

If you have questions, please contact Temprite’s Customer Service Department at 214-638-6010. We’ll be glad to help.

**Temprite**

**Keeps You**

**Warm**

# : Table of Contents



## Performance Tables

TAP Air Delivery Table .....	4-5
TAP Engineering Data .....	6-7
TAS Air Delivery Table .....	8
TAS Engineering Data .....	9
TAC Air Delivery Table and Engineering Data .....	10
TAA Air Delivery Table .....	11-14
TAA Engineering Data .....	15-18
TAC & TAA DX Coil Data .....	19
TAC & TAA CW Coil Data .....	20
TAJ Air Delivery Tables .....	21
TAJ Engineering Data .....	22
TAJ DX and CW Coil Data .....	23

## Dimensions

TAP Basic Unit .....	24-25
TAP Basic Unit with Outside Air and Return Air Dampers ...	26-27
TAP Basic Unit with Outside Air and Return Air Dampers and V-Bank Filter Section .....	28-29
TAS Basic Unit .....	30-31
TAS Basic Unit with Outside Air and Return Air Dampers ...	32-33
TAS Basic Unit with Outside Air and Return Air Dampers and V-Bank Filter Section .....	34-35
TAC Cooling Only .....	36
TAA Cooling Only .....	37
TAA Heating and Cooling .....	38
TAJ Heating Only .....	39
TAJ Heating and Cooling .....	40

Typical Gas Piping Layout .....	41
---------------------------------	----

Equipment Sizing .....	42
------------------------	----

## Guide Specifications

TAP .....	43-44
TAS .....	45
TAC .....	46-47
TAA .....	48-49
TAJ .....	50-51

# Performance Table

TAP Air Delivery Table									
TAP Model No. (1), (2)	SCFM	Fan No. and Size	Fan Motors - Qty. @ HP/Total Amp Draw (3)				High Fire Output (Minimum)	Air Temperature Rise (5)	
			Standard Arrangement		Alternate Arrangement		High Fire Output (Maximum) (4)		
			W/O Filters	W/ Filters	W/O Filters	W/V-Bank Filters			
75/40	6,600	1 - 30"	1@1.5/3.0	1@1.5/3.0	1@1.5/3.0	1@2.0/3.4	350,000	49	56
	7,400	2 - 30"	2@.5/2.2	2@.75/3.2	2@.75/3.2	2@1.0/4.2	400,000	44	50
	8,100		2@.5/2.2	2@1.0/4.2	2@.75/3.2	2@1.0/4.2		40	46
75/55	9,100	2 - 30"	2@.75/3.2	2@1.0/4.2	2@.75/3.2	2@1.5/6.0	450,000	46	56
	10,100		2@.75/3.2	2@1.5/6.0	2@1.0/4.2	2@1.5/6.0	550,000	41	50
	11,100		2@1.0/4.2	2@1.5/6.0	2@1.5/6.0	2@2.0/6.8		37	46
100/55	12,400	2 - 30"	2@1.0/4.2	2@1.5/6.0	2@1.5/6.0	2@2.0/6.8	450,000	33	41
	13,800		2@1.0/4.2	2@2.0/6.8	2@1.5/6.0	2@3.0/9.6	550,000	30	37
	15,200		2@1.5/6.0	2@2.0/6.8	2@1.5/6.0	2@3.0/9.6		27	33
100/75	12,400	2 - 30"	2@1.0/4.2	2@1.5/6.0	2@1.5/6.0	2@2.0/6.8	650,000	48	56
	13,800		2@1.0/4.2	2@2.0/6.8	2@1.5/6.0	2@3.0/9.6	750,000	43	50
	15,200		2@1.5/6.0	2@2.0/6.8	2@1.5/6.0	2@3.0/9.6		39	45
125/75	16,600	2 - 36"	2@1.5/6.0	2@2.0/6.8	2@2.0/6.8	2@3.0/9.6	650,000	36	42
	18,500		2@1.5/6.0	2@3.0/9.6	2@2.0/6.8	2@3.0/9.6	750,000	32	37
	20,400		2@1.5/6.0	2@3.0/9.6	2@2.0/6.8	2@5.0/15.2		29	34
125/100	16,600	2 - 36"	2@1.5/6.0	2@2.0/6.8	2@2.0/6.8	2@3.0/9.6	850,000	47	56
	18,500		2@1.5/6.0	2@3.0/9.6	2@2.0/6.8	2@3.0/9.6	1,000,000	42	50
	20,400		2@1.5/6.0	2@3.0/9.6	2@2.0/6.8	2@5.0/15.2		38	45
175/75	22,000	2 - 42"	2@1.5/6.0	2@3.0/9.6	2@2.0/6.8	2@3.0/9.6	650,000	27	31
	24,500		2@1.5/6.0	2@3.0/9.6	2@2.0/6.8	2@5.0/15.2	750,000	24	28
	27,000		2@2.0/6.8	2@3.0/9.6	2@3.0/9.6	2@5.0/15.2		22	26
175/100	22,000	2 - 42"	2@1.5/6.0	2@3.0/9.6	2@2.0/6.8	2@3.0/9.6	850,000	36	42
	24,500		2@1.5/6.0	2@3.0/9.6	2@2.0/6.8	2@5.0/15.2	1,000,000	32	38
	27,000		2@2.0/6.8	2@3.0/9.6	2@3.0/9.6	2@5.0/15.2		29	34
200/100	29,200	2 - 42"	2@2.0/6.8	2@3.0/9.6	2@3.0/9.6	2@5.0/15.2	850,000	27	32
	32,500		2@2.0/6.8	2@5.0/15.2	2@3.0/9.6	2@5.0/15.2	1,000,000	24	28
	35,800		2@3.0/9.6	2@5.0/15.2	2@5.0/15.2	2@5.0/15.2		22	26
200/175	29,200	2 - 42"	2@2.0/6.8	2@3.0/9.6	2@3.0/9.6	2@5.0/15.2	1,250,000	39	55
	32,500		2@2.0/6.8	2@5.0/15.2	2@3.0/9.6	2@5.0/15.2	1,750,000	35	50
	35,800		2@3.0/9.6	2@5.0/15.2	2@5.0/15.2	2@5.0/15.2		32	45
250/100	35,100	2 - 48"	2@3.0/9.6	2@5.0/15.2	2@3.0/9.6	2@5.0/15.2	850,000	22	26
	39,000		2@3.0/9.6	2@5.0/15.2	2@5.0/15.2	2@7.5/22.0	1,000,000	20	24
	42,900		2@3.0/9.6	2@5.0/15.2	2@5.0/15.2	2@7.5/22.0		18	21

- (1) Base unit priced by motor HP for each model.
- (2) For large spaces with low heat requirements, combine TAP and TAS Series Air Turnover units.
- (3) Typical amps shown are based on 460V power supply. For 230V power supply, multiply above amps x 2.0. For 208V power supply, multiply above amps x 2.2.
- (4) Upper number indicates lowest full output and bottom number indicates maximum full output available for each model.
- (5) Indicates temperature rise for outputs at CFM shown. Order stainless steel heat exchangers when 30% or more of winter outside air is introduced, or temperature rise at minimum firing rate is below 10°F.

# Performance Table

TAP Air Delivery Table									
TAP Model No. (1), (2)	SCFM	Fan No. and Size	Fan Motors - Qty. @ HP/Total Amp Draw (3)				High Fire Output (Minimum)	Air Temperature Rise (5)	
			Standard Arrangement		Alternate Arrangement		High Fire Output (Maximum) (4)		
			W/O Filters	W/ Filters	W/O Filters	W/V-Bank Filters			
250/175	35,100	2 - 48"	2@3.0/9.6	2@5.0/15.2	2@3.0/9.6	2@5.0/15.2	1,250,000	33	46
	39,000		2@3.0/9.6	2@5.0/15.2	2@5.0/15.2	2@7.5/22.0	1,750,000	30	41
	42,900		2@3.0/9.6	2@5.0/15.2	2@5.0/15.2	2@7.5/22.0		27	38
300/175	41,400	2 - 48"	2@3.0/9.6	2@5.0/15.2	2@5.0/15.2	2@7.5/22.0	1,250,000	28	39
	46,000		2@5.0/15.2	2@7.5/22.0	2@5.0/15.2	2@7.5/22.0	1,750,000	25	35
	49,000		2@5.0/15.2	2@7.5/22.0	2@5.0/15.2	2@7.5/22.0		24	33
300/250	41,400	2 - 48"	2@3.0/9.6	2@5.0/15.2	2@5.0/15.2	2@7.5/22.0	2,000,000	45	56
	46,000		2@5.0/15.2	2@7.5/22.0	2@5.0/15.2	2@7.5/22.0	2,500,000	40	50
	49,000		2@5.0/15.2	2@7.5/22.0	2@5.0/15.2	2@7.5/22.0		38	47
400/250	51,000	2 - 54"	2@5.0/15.2	2@7.5/22.0	2@5.0/15.2	2@7.5/22.0	2,000,000	36	45
	55,500		2@5.0/15.2	2@7.5/22.0	2@5.0/15.2	2@10.0/28	2,500,000	33	42
	61,000		2@5.0/15.2	2@7.5/22.0	2@7.5/22.0	2@10.0/28		30	38
400/300	51,000	2 - 54"	2@5.0/15.2	2@7.5/22.0	2@5.0/15.2	2@7.5/22.0	2,750,000	50	54
	55,500		2@5.0/15.2	2@7.5/22.0	2@5.0/15.2	2@10.0/28	3,000,000	46	50
	61,000		2@5.0/15.2	2@7.5/22.0	2@7.5/22.0	2@10.0/28		42	45
600/300	66,600	2 - 60"	2@5.0/15.2	2@10.0/28	2@7.5/22.0	2@15.0/42	2,750,000	38	42
	74,000		2@7.5/22.0	2@10.0/28	2@10.0/28	2@15.0/42	3,000,000	34	37
	81,400		2@7.5/22.0	2@15.0/42	2@10.0/28	2@15.0/42		31	34
600/400	66,600	2 - 60"	2@5.0/15.2	2@10.0/28	2@7.5/22.0	2@15.0/42	3,250,000	45	55
	74,000		2@7.5/22.0	2@10.0/28	2@10.0/28	2@15.0/42	4,000,000	40	50
	81,400		2@7.5/22.0	2@15.0/42	2@10.0/28	2@15.0/42		37	45
600S/400	83,200	2 - 60"	2@7.5/22.0	2@15.0/42	2@10.0/28	2@15.0/42	3,250,000	36	44
	92,500		2@10.0/28	2@15.0/42	2@15.0/42	2@15.0/42	4,000,000	32	40
	100,000		2@15.0/42	2@15.0/42	2@15.0/42	2@15.0/42		30	37
600S/600	83,200	2 - 60"	2@7.5/22.0	2@15.0/42	2@10.0/28	2@15.0/42	4,500,000	50	66
	92,500		2@10.0/28	2@15.0/42	2@15.0/42	2@15.0/42	6,000,000	45	60
	100,000		2@15.0/42	2@15.0/42	2@15.0/42	2@15.0/42		41	55
600SS/400	123,000	3 - 60"	3@7.5/33	NA	3@10.0/42	3@15.0/63	3,250,000	24	30
	136,500		3@10.0/42	NA	3@15.0/63	3@15.0/63	4,000,000	22	27
	150,000		3@15.0/63	NA	3@15.0/63	3@15.0/63		20	25
600SS/600	123,000	3 - 60"	3@7.5/33	NA	3@10.0/42	3@15.0/63	4,500,000	34	45
	136,500		3@10.0/42	NA	3@15.0/63	3@15.0/63	6,000,000	30	41
	150,000		3@15.0/63	NA	3@15.0/63	3@15.0/63		28	37

- (1) Base unit priced by motor HP for each model.
- (2) For large spaces with low heat requirements, combine TAP and TAS Series Air Turnover units.
- (3) Typical amps shown are based on 460V power supply. For 230V power supply, multiply above amps x 2.0. For 208V power supply, multiply above amps x 2.2.
- (4) Upper number indicates lowest full output and bottom number indicates maximum full output available for each model.
- (5) Indicates temperature rise for outputs at CFM shown. Order stainless steel heat exchangers when 30% or more of winter outside air is introduced, or temperature rise at minimum firing rate is below 10°F.

# Performance Table

TAP Engineering Data								
TAP Model No. (1), (2)	SCFM	High Fire Output (Minimum)	Draft Inducer HP/Amp Draw (4), (5)	Burner Motor HP/Amp Draw (4), (5)	Pipe Size (6)	Minimum Stack Size	Flat Bank Filters (4 Sides)	V-Bank Filters
		High Fire Output (Maximum) (3)						
75/40	6,600	350,000	.33/1.65	.25/1.65	1"	8"	14 16 x 25 x 2	12 20 x 20 x 2
	7,400	400,000						
	8,100							
75/55	9,100	450,000	.33/1.65	.25/1.65	1"	8"	14 16 x 25 x 2	12 20 x 20 x 2
	10,100	550,000						
	11,100							
100/55	12,400	450,000	.33/1.65	.25/1.65	1"	8"	22 16 x 20 x 2	16 20 x 20 x 2
	13,800	550,000						
	15,200							
100/75	12,400	650,000	.50/2.2	.33/2.2	1 1/4"	10"	22 16 x 20 x 2	16 20 x 20 x 2
	13,800	750,000						
	15,200							
125/75	16,600	650,000	.50/2.2	.33/2.2	1 1/4"	10"	22 16 x 25 x 2	30 20 x 20 x 2
	18,500	750,000						
	20,400							
125/100	16,600	850,000	.50/2.2	.33/2.2	1 1/2"	10"	22 16 x 25 x 2	30 20 x 20 x 2
	18,500	1,000,000						
	20,400							
175/75	22,000	650,000	.50/2.2	.33/2.2	1 1/4"	10"	22 16 x 25 x 2	30 20 x 20 x 2
	24,500	750,000						
	27,000							
175/100	22,000	850,000	.50/2.2	.33/2.2	1 1/2"	10"	22 16 x 25 x 2	30 20 x 20 x 2
	24,500	1,000,000						
	27,000							
200/100	29,200	850,000	.50/2.2	.33/2.2	1 1/2"	10"	34 20 x 20 x 2	36 20 x 20 x 2
	32,500	1,000,000						
	35,800							
200/175	29,200	1,250,000	2.0/3.4	.33/3.3	1 1/2"	12"	34 20 x 20 x 2	36 20 x 20 x 2
	32,500	1,750,000			2"			
	35,800							
250/100	35,100	850,000	.50/2.2	.33/2.2	1 1/2"	10"	34 20 x 20 x 2	36 20 x 20 x 2
	39,000	1,000,000						
	42,900							

(1) Base unit priced by motor HP for each model.

(2) For large spaces with low heat requirements, combine TAP and TAS Series Air Turnover units.

(3) Upper number indicates lowest full output and bottom number indicates maximum full output available for each model.

(4) Typical amps shown are based on 460V power supply. For single phase motors, the load is based on control transformer sized to handle burner and/or draft inducer motors.

(5) Typical amps shown are based on 460V power supply. For 230V power supply, multiply above amps x 2.0. For 208V power supply, multiply above amps x 2.2.

(6) Gas pipe size is based on standard manifold with 8" to 14" W.C. gas pressure.

# Performance Table

TAP Engineering Data								
TAP Model No. (1), (2)	SCFM	High Fire Output (Minimum)	Draft Inducer HP/Amp Draw (4), (5)	Burner Motor HP/Amp Draw (4), (5)	Pipe Size (6)	Minimum Stack Size	Flat Bank Filters (4 Sides)	V-Bank Filters
		High Fire Output (Maximum) (3)						
250/175	35,100	1,250,000	2.0/3.4	.33/3.3	1 1/2"	12"	34 20 x 20 x 2	36 20 x 20 x 2
	39,000	1,750,000						
	42,900							
300/175	41,400	1,250,000	2.0/3.4	.33/3.3	1 1/2"	12"	38 20 x 25 x 2	49 20 x 20 x 2
	46,000	1,750,000						
	49,000							
300/250	41,400	2,000,000	2.0/3.4	.75/1.4	2"	14"	38	49
	46,000	2,500,000	5.0/7.6	1.5/2.6	2 1/2"	16"	20 x 25 x 2	20 x 20 x 2
	49,000							
400/250	51,000	2,000,000	2.0/3.4	.75/1.4	2"	14"	42	64
	55,500	2,500,000	5.0/7.6	1.5/2.6	2 1/2"	16"	20 x 25 x 2	20 x 20 x 2
	61,000							
400/300	51,000	2,750,000	5.0/7.6	1.5/2.6	2 1/2"	16"	42 20 x 25 x 2	64 20 x 20 x 2
	55,500	3,000,000						
	61,000							
600/300	66,600	2,750,000	5.0/7.6	1.5/2.6	2 1/2"	16"	50 20 x 25 x 2	90 20 x 25 x 2
	74,000	3,000,000						
	81,400							
600/400	66,600	3,250,000	5.0/7.6	1.5/2.6	2 1/2"	16"	50 20 x 25 x 2	90 20 x 25 x 2
	74,000	4,000,000		3.0/4.8	3"			
	81,400							
600S/400	83,200	3,250,000	5.0/7.6	1.5/2.6	2 1/2"	16"	63 20 x 25 x 2	100 20 x 25 x 2
	92,500	4,000,000		3.0/4.8	3"			
	100,000							
600S/600	83,200	4,500,000	5.0/7.6	3.0/4.8	3"	16"	63 20 x 25 x 2	100 20 x 25 x 2
	92,500	6,000,000		5.0/7.6	3"			
	100,000							
600SS/400	123,000	3,250,000	5.0/7.6	1.5/2.6	2 1/2"	16"	NA	100 20 x 25 x 2
	136,500	4,000,000		3.0/4.8	3"			
	150,000							
600SS/600	123,000	4,500,000	5.0/7.6	3.0/4.8	3"	16"	NA	100 20 x 25 x 2
	136,500	6,000,000		5.0/7.6	3"			
	150,000							

(1) Base unit priced by motor HP for each model.

(2) For large spaces with low heat requirements, combine TAP and TAS Series Air Turnover units.

(3) Upper number indicates lowest full output and bottom number indicates maximum full output available for each model.

(4) Typical amps shown are based on 460V power supply. For single phase motors, the load is based on control transformer sized to handle burner and/or draft inducer motors.

(5) Typical amps shown are based on 460V power supply. For 230V power supply, multiply above amps x 2.0. For 208V power supply, multiply above amps x 2.2.

(6) Gas pipe size is based on standard manifold with 8" to 14" W.C. gas pressure.

# Performance Table

TAS Air Delivery Table						
TAS Model No. (1), (2)	SCFM	Fan No. and Size	Fan Motors - Qty. @ HP/Total Amp Draw (3)			
			Standard Arrangement		Alternate Arrangement	
			W/O Filters	W/Flat Filters	W/O Filters	W/V-Bank Filters
75	9,100	2 - 30"	2@.75/3.2	2@.75/3.2	2@.75/3.2	2@1.0/4.2
	10,100		2@.75/3.2	2@1.0/4.2	2@1.0/4.2	2@1.5/6.0
	11,100		2@1.0/4.2	2@1.5/6.0	2@1.0/4.2	2@1.5/6.0
125	16,600	2 - 36"	2@.75/3.2	2@2.0/6.8	2@1.5/6.0	2@2.0/6.8
	18,500		2@.75/3.2	2@2.0/6.8	2@1.5/6.0	2@3.0/9.6
	20,400		2@1.0/4.2	2@2.0/6.8	2@1.5/6.0	2@3.0/9.6
200	29,200	2 - 42"	2@2.0/6.8	2@3.0/9.6	2@2.0/6.8	2@3.0/9.6
	32,500		2@2.0/6.8	2@3.0/9.6	2@2.0/6.8	2@5.0/15.2
	35,800		2@2.0/6.8	2@5.0/15.2	2@3.0/9.6	2@5.0/15.2
300	41,400	2 - 48"	2@2.0/6.8	2@5.0/15.2	2@3.0/9.6	2@5.0/15.2
	46,000		2@3.0/9.6	2@5.0/15.2	2@5.0/15.2	2@7.5/22.0
	49,000		2@3.0/9.6	2@5.0/15.2	2@5.0/15.2	2@7.5/22.0
400	51,000	2 - 54"	2@3.0/9.6	2@5.0/15.2	2@5.0/15.2	2@7.5/22.0
	55,500		2@3.0/9.6	2@5.0/15.2	2@5.0/15.2	2@7.5/22.0
	61,000		2@5.0/15.2	2@7.5/22.0	2@5.0/15.2	2@7.5/22.0
600	66,600	2 - 60"	2@5.0/15.2	2@7.5/22.0	2@5.0/15.2	2@10.0/28
	74,000		2@5.0/15.2	2@10.0/28	2@7.5/22.0	2@10.0/28
	81,400		2@7.5/22.0	2@10.0/28	2@7.5/22.0	2@15.0/42
600S	83,200	2 - 60"	2@7.5/22.0	2@10.0/28	2@7.5/22.0	2@15.0/42
	92,500		2@7.5/22.0	2@10.0/28	2@10.0/28	2@15.0/42
	100,000		2@10.0/22.0	2@15.0/42	2@15.0/42	2@15.0/42
600SS	123,000	3 - 60"	3@7.5/33	NA	3@7.5/33	3@10.0/42
	136,500		3@7.5/33	NA	3@10.0/42	3@15.0/63
	150,000		3@10.0/42	NA	3@15.0/63	3@15.0/63

(1) Base unit priced by motor HP for each model.

(2) For large spaces with low heat requirements, combine TAS and TAP Series Air Turnover units.

(3) Typical amps shown are based on 460V power supply. For 230V power supply, multiply above amps x 2.0. For 208V power supply, multiply above amps x 2.2.

# Performance Table

TAS Engineering Data				
TAS Model No. (1), (2)	SCFM	Fan No. and Size	Flat Bank Filters	V-Bank Filters
75	9,100	2 - 30"	14	12
	10,100		16 x 25 x 2	20 x 20 x 2
	11,100			
125	16,600	2 - 36"	22	30
	18,500		16 x 25 x 2	20 x 20 x 2
	20,400			
200	29,200	2 - 42"	34	36
	32,500		20 x 20 x 2	20 x 20 x 2
	35,800			
300	41,400	2 - 48"	38	49
	46,000		20 x 25 x 2	20 x 20 x 2
	49,000			
400	51,000	2 - 54"	42	64
	55,500		20 x 25 x 2	20 x 20 x 2
	61,000			
600	66,600	2 - 60"	50	90
	74,000		20 x 25 x 2	20 x 25 x 2
	81,400			
600S	83,200	2 - 60"	63	100
	92,500		20 x 25 x 2	20 x 25 x 2
	100,000			
600SS	123,000	3 - 60"	NA	100
	136,500			20 x 25 x 2
	150,000			

(1) Base unit priced by motor HP for each model.

(2) For large spaces with low heat requirements, combine TAS and TAP Series Air Turnover units.

# Performance Table

TAC Air Delivery Table and Engineering Data							
TAC Model No. (1)	SCFM	Fan No. and Size	Fan Motors - Qty.@ HP/Total Amp Draw (2)			Nominal Cooling Tons (3)	V-Bank Filters
			Standard Arrangement	Alternate Arrangement With One Damper	Alternate Arrangement With Mixing Dampers		
"175 Cooling Only"	13,000	2 - 42"	2 @ 2.0 / 6.8	2 @ 2.0 / 6.8	2 @ 2.0 / 6.8	26.8	30 20 x 20 x 2
	14,000		2 @ 3.0 / 9.6	2 @ 3.0 / 9.6	2 @ 3.0 / 9.6	28.4	
	15,000		2 @ 3.0 / 9.6	2 @ 3.0 / 9.6	2 @ 3.0 / 9.6	29.9	
	16,000		2 @ 3.0 / 9.6	2 @ 3.0 / 9.6	2 @ 3.0 / 9.6	33.1	
	17,000		2 @ 3.0 / 9.6	2 @ 5.0 / 15.2	2 @ 5.0 / 15.2	34.7	
	18,000		2 @ 5.0 / 15.2	2 @ 5.0 / 15.2	2 @ 5.0 / 15.2	36.3	
	19,000		2 @ 5.0 / 15.2	2 @ 5.0 / 15.2	2 @ 5.0 / 15.2	38.7	
	20,000		2 @ 5.0 / 15.2	2 @ 5.0 / 15.2	2 @ 5.0 / 15.2	40.2	
"250 Cooling Only"	20,000	2 - 48"	2 @ 3.0 / 9.6	2 @ 3.0 / 9.6	2 @ 3.0 / 9.6	42.2	36 20 x 20 x 2
	22,000		2 @ 5.0 / 15.2	2 @ 5.0 / 15.2	2 @ 5.0 / 15.2	45.0	
	24,000		2 @ 5.0 / 15.2	2 @ 5.0 / 15.2	2 @ 5.0 / 15.2	50.6	
	26,000		2 @ 5.0 / 15.2	2 @ 5.0 / 15.2	2 @ 5.0 / 15.2	53.5	
	28,000		2 @ 5.0 / 15.2	2 @ 7.5 / 22.0	2 @ 7.5 / 22.0	57.7	
	30,000		2 @ 7.5 / 22.0	2 @ 7.5 / 22.0	2 @ 7.5 / 22.0	60.5	
"300 Cooling Only"	29,000	2 - 48"	2 @ 5.0 / 15.2	2 @ 5.0 / 15.2	2 @ 5.0 / 15.2	58.1	49 20 x 20 x 2
	31,000		2 @ 5.0 / 15.2	2 @ 5.0 / 15.2	2 @ 5.0 / 15.2	61.3	
	33,000		2 @ 7.5 / 22.0	2 @ 7.5 / 22.0	2 @ 7.5 / 22.0	65.8	
	35,000		2 @ 7.5 / 22.0	2 @ 7.5 / 22.0	2 @ 7.5 / 22.0	68.5	
	37,000		2 @ 7.5 / 22.0	2 @ 7.5 / 22.0	2 @ 7.5 / 22.0	73.8	
39,000	2 @ 7.5 / 22.0	2 @ 7.5 / 22.0	2 @ 7.5 / 22.0	77.0			
"400 Cooling Only"	37,000	2 - 54"	2 @ 7.5 / 22.0	2 @ 7.5 / 22.0	2 @ 7.5 / 22.0	75.4	64 20 x 20 x 2
	39,000		2 @ 7.5 / 22.0	2 @ 7.5 / 22.0	2 @ 7.5 / 22.0	78.6	
	41,000		2 @ 7.5 / 22.0	2 @ 7.5 / 22.0	2 @ 7.5 / 22.0	81.3	
	43,000		2 @ 7.5 / 22.0	2 @ 10.0 / 28.0	2 @ 10.0 / 28.0	87.2	
	45,000		2 @ 10.0 / 28.0	2 @ 10.0 / 28.0	2 @ 10.0 / 28.0	90.3	
	47,000		2 @ 10.0 / 28.0	2 @ 10.0 / 28.0	2 @ 10.0 / 28.0	93.1	
	49,000		2 @ 10.0 / 28.0	2 @ 10.0 / 28.0	2 @ 10.0 / 28.0	99.0	
	51,000		2 @ 10.0 / 28.0	2 @ 15.0 / 42.0	2 @ 15.0 / 42.0	102.1	
53,000	2 @ 15.0 / 42.0	2 @ 15.0 / 42.0	2 @ 15.0 / 42.0	104.9			
"600 Cooling Only"	58,000	2 - 60"	2 @ 10.0 / 28.0	2 @ 15.0 / 42.0	2 @ 15.0 / 42.0	114.6	90 20 x 25 x 2
	61,000		2 @ 15.0 / 42.0	2 @ 15.0 / 42.0	2 @ 15.0 / 42.0	119.3	
	64,000		2 @ 15.0 / 42.0	2 @ 15.0 / 42.0	2 @ 15.0 / 42.0	123.6	
	67,000		2 @ 15.0 / 42.0	2 @ 15.0 / 42.0	2 @ 15.0 / 42.0	132.6	
	70,000		2 @ 15.0 / 42.0	2 @ 20.0 / 54.0	2 @ 20.0 / 54.0	137.4	
	73,000		2 @ 20.0 / 54.0	2 @ 20.0 / 54.0	2 @ 20.0 / 54.0	142.1	
	76,000		2 @ 20.0 / 54.0	2 @ 20.0 / 54.0	2 @ 20.0 / 54.0	144.3	
	79,000		2 @ 25.0 / 68.0	2 @ 25.0 / 68.0	2 @ 25.0 / 68.0	146.9	
	81,000		2 @ 25.0 / 68.0	2 @ 25.0 / 68.0	2 @ 25.0 / 68.0	148.0	

**NOTES:**

(1) Base unit priced by CFM and matching coil size.

(2) Typical amps shown are based on 460V power supply. For 230V power supply, multiple above amps x 2.0. For 208V power supply, multiply above amps x 2.2.

(3) Nominal cooling capacity based on DX coils with 2) 4 Row coils in "A" arrangement, 45° suction temperature and 80°/67° return air temperature. See CW Coil Data for CW capacities.

# Performance Table

TAA Air Delivery Table								
TAA Model No. (1)	SCFM	Blowers	Blower Motor - Qty.@ HP/Total Amp Draw (2)		Nominal Cooling Tons (3)	High Fire Output (Min.)	Air Temperature Rise (5)	
			Standard Arrangement	Alternate Arrangement With Mixing Dampers		High Fire Output (Max.) (4)		
175 Cooling Only	13,000	3) 18" x 13"	1 @ 7-1/2/11.0	1 @ 7-1/2/11.0	26.8	NA	—	—
	14,000		1 @ 7-1/2/11.0	1 @ 7-1/2/11.0	28.4		—	—
	15,000		1 @ 10/14.0	1 @ 10/14.0	29.9		—	—
	16,000		1 @ 10/14.0	1 @ 10/14.0	33.1		—	—
	17,000		1 @ 15/21.0	1 @ 15/21.0	34.7		—	—
	18,000		1 @ 15/21.0	1 @ 15/21.0	36.3		—	—
	19,000		1 @ 15/21.0	1 @ 15/21.0	38.7		—	—
	20,000		1 @ 15/21.0	1 @ 15/21.0	40.2		—	—
	175/75		13,000	3) 18" x 13"	1 @ 7-1/2/11.0		1 @ 7-1/2/11.0	26.8
14,000		1 @ 7-1/2/11.0	1 @ 7-1/2/11.0		28.4	43	49	
15,000		1 @ 10/14.0	1 @ 10/14.0		29.9	40	46	
16,000		1 @ 10/14.0	1 @ 10/14.0		33.1	37	43	
17,000		1 @ 15/21.0	1 @ 15/21.0		34.7	35	41	
18,000		1 @ 15/21.0	1 @ 15/21.0		36.3	33	38	
19,000		1 @ 15/21.0	1 @ 15/21.0		38.7	32	36	
20,000		1 @ 15/21.0	1 @ 20/27.0		40.2	30	35	
175/100		13,000	3) 18" x 13"		1 @ 7-1/2/11.0	1 @ 7-1/2/11.0	26.8	850,000 1,000,000
	14,000	1 @ 7-1/2/11.0		1 @ 7-1/2/11.0	28.4	56	66	
	15,000	1 @ 10/14.0		1 @ 10/14.0	29.9	52	61	
	16,000	1 @ 10/14.0		1 @ 10/14.0	33.1	49	58	
	17,000	1 @ 15/21.0		1 @ 15/21.0	34.7	46	54	
	18,000	1 @ 15/21.0		1 @ 15/21.0	36.3	44	51	
	19,000	1 @ 15/21.0		1 @ 15/21.0	38.7	41	49	
	20,000	1 @ 15/21.0		1 @ 20/27.0	40.2	39	46	
	250 Cooling Only	20,000		3) 18" x 18"	1 @ 15/21.0	1 @ 20/27.0	42.2	
22,000		1 @ 20/27.0	1 @ 20/27.0		45.0	—	—	
24,000		1 @ 20/27.0	1 @ 25/34.0		50.6	—	—	
26,000		1 @ 25/34.0	1 @ 25/34.0		53.5	—	—	
28,000		1 @ 30/40.0	1 @ 30/40.0		57.7	—	—	
30,000		1 @ 40/52.0	1 @ 40/52.0		60.5	—	—	

(1) Base unit priced by CFM and matching coil size.

(2) Typical amps shown are based on 460V power supply. For 230V power supply, multiply above amps x 2.0. For 208V power supply, multiply above amps x 2.2.

(3) Nominal cooling capacity based on DX coils with 2) 4 Row coils in "A" arrangement, 45° Suction temperature and 80°/67° return air temperature. See CW Coil Data for CW capacities.

(4) Upper number indicates lowest full output and bottom number indicates maximum full output available for each model.

(5) Indicates temperature rise for outputs at CFM shown. Order stainless steel heat exchangers when 30% or more of winter outside air is introduced, or temperature rise at minimum firing rate is below 10°F.

# Performance Table

TAA Air Delivery Table								
TAA Model No. (1)	SCFM	Blowers	Blower Motor - Qty. @ HP/Total Amp Draw (2)		Nominal Cooling Tons (3)	High Fire Output (Min.)	Air Temperature Rise (5)	
			Standard Arrangement	Alternate Arrangement With Mixing Dampers		High Fire Output (Max.) (4)		
250/100	20,000	3) 18" x 18"	1 @ 15/21.0	1 @ 20/27.0	42.2	850,000 1,000,000	39	46
	22,000		1 @ 20/27.0	1 @ 20/27.0	45.0		36	42
	24,000		1 @ 20/27.0	1 @ 25/34.0	50.6		33	38
	26,000		1 @ 25/34.0	1 @ 25/34.0	53.5		30	35
	28,000		1 @ 30/40.0	1 @ 30/40.0	57.7		28	33
	30,000		1 @ 40/52.0	1 @ 40/52.0	60.5		26	31
250/175	20,000	3) 18" x 18"	1 @ 15/21.0	1 @ 20/27.0	42.2	1,250,000 1,750,000	58	81
	22,000		1 @ 20/27.0	1 @ 20/27.0	45.0		52	73
	24,000		1 @ 20/27.0	1 @ 25/34.0	50.6		48	67
	26,000		1 @ 25/34.0	1 @ 25/34.0	53.5		44	62
	28,000		1 @ 30/40.0	1 @ 30/40.0	57.7		41	58
	30,000		1 @ 40/52.0	1 @ 40/52.0	60.5		38	54
300 Cooling Only	29,000	3) 20" x 20"	1 @ 20/27.0	1 @ 25/34.0	58.1	NA	—	—
	31,000		1 @ 25/34.0	1 @ 25/34.0	61.3		—	—
	33,000		1 @ 25/34.0	1 @ 25/34.0	65.8		—	—
	35,000		1 @ 25/34.0	1 @ 30/40.0	68.5		—	—
	37,000		1 @ 30/40.0	1 @ 30/40.0	73.8		—	—
	39,000		1 @ 40/52.0	1 @ 40/52.0	77.0		—	—
300/175	29,000	3) 20" x 20"	1 @ 20/27.0	1 @ 25/34.0	58.1	1,250,000 1,750,000	40	56
	31,000		1 @ 25/34.0	1 @ 25/34.0	61.3		37	52
	33,000		1 @ 25/34.0	1 @ 25/34.0	65.8		35	49
	35,000		1 @ 30/40.0	1 @ 30/40.0	68.5		33	46
	37,000		1 @ 30/40.0	1 @ 40/52.0	73.8		31	44
	39,000		1 @ 40/52.0	1 @ 40/52.0	77.0		30	41
300/250	29,000	3) 20" x 20"	1 @ 20/27.0	1 @ 25/34.0	58.1	2,000,000 2,500,000	64	79
	31,000		1 @ 25/34.0	1 @ 25/34.0	61.3		59	74
	33,000		1 @ 25/34.0	1 @ 25/34.0	65.8		56	70
	35,000		1 @ 30/40.0	1 @ 30/40.0	68.5		53	66
	37,000		1 @ 30/40.0	1 @ 40/52.0	73.8		50	62
	39,000		1 @ 40/52.0	1 @ 40/52.0	77.0		47	59

(1) Base unit priced by CFM and matching coil size.

(2) Typical amps shown are based on 460V power supply. For 230V power supply, multiply above amps x 2.0. For 208V power supply, multiply above amps x 2.2.

(3) Nominal cooling capacity based on DX coils with 2) 4 Row coils in "A" arrangement, 45° Suction temperature and 80°/67° return air temperature. See CW Coil Data for CW capacities.

(4) Upper number indicates lowest full output and bottom number indicates maximum full output available for each model.

(5) Indicates temperature rise for outputs at CFM shown. Order stainless steel heat exchangers when 30% or more of winter outside air is introduced, or temperature rise at minimum firing rate is below 10°F.

# Performance Table

TAA Air Delivery Table								
TAA Model No. (1)	SCFM	Blowers	Blower Motor - Qty.@ HP/Total Amp Draw (2)		Nominal Cooling Tons (3)	High Fire Output (Min.)	Air Temperature Rise (5)	
			Standard Arrangement	Alternate Arrangement With Mixing Dampers		High Fire Output (Max.) (4)		
400 Cooling Only	37,000	3) 22" x 22"	1 @ 25/34.0	1 @ 30/40.0	75.4	NA	—	—
	39,000		1 @ 30/40.0	1 @ 30/40.0	78.6		—	—
	41,000		1 @ 30/40.0	1 @ 40/52.0	81.3		—	—
	43,000		1 @ 40/52.0	1 @ 40/52.0	87.2		—	—
	45,000		1 @ 40/52.0	1 @ 40/52.0	90.3		—	—
	47,000		1 @ 40/52.0	1 @ 40/52.0	93.1		—	—
	49,000		1 @ 50/65.0	1 @ 50/65.0	99.0		—	—
	51,000		1 @ 50/65.0	1 @ 50/65.0	102.1		—	—
	53,000		1 @ 60/77.0	1 @ 60/77.0	104.9		—	—
400/250	37,000	3) 22" x 22"	1 @ 25/34.0	1 @ 25/34.0	75.4	2,000,000 2,500,000	50	62
	39,000		1 @ 30/40.0	1 @ 30/40.0	78.6		47	59
	41,000		1 @ 30/40.0	1 @ 40/52.0	81.3		45	56
	43,000		1 @ 40/52.0	1 @ 40/52.0	87.2		43	54
	45,000		1 @ 40/52.0	1 @ 40/52.0	90.3		41	51
	47,000		1 @ 40/52.0	1 @ 50/65.0	93.1		39	49
	49,000		1 @ 50/65.0	1 @ 50/65.0	99.0		38	47
	51,000		1 @ 50/65.0	1 @ 60/77.0	102.1		36	45
	53,000		1 @ 60/77.0	1 @ 60/77.0	104.9		35	43
400/300	37,000	3) 22" x 22"	1 @ 25/34.0	1 @ 25/34.0	75.4	2,750,000 3,000,000	69	75
	39,000		1 @ 30/40.0	1 @ 30/40.0	78.6		65	71
	41,000		1 @ 30/40.0	1 @ 40/52.0	81.3		62	67
	43,000		1 @ 40/52.0	1 @ 40/52.0	87.2		59	64
	45,000		1 @ 40/52.0	1 @ 40/52.0	90.3		56	61
	47,000		1 @ 40/52.0	1 @ 50/65.0	93.1		54	59
	49,000		1 @ 50/65.0	1 @ 50/65.0	99.0		52	56
	51,000		1 @ 50/65.0	1 @ 60/77.0	102.1		50	54
	53,000		1 @ 60/77.0	1 @ 60/77.0	104.9		48	52

(1) Base unit priced by CFM and matching coil size.

(2) Typical amps shown are based on 460V power supply. For 230V power supply, multiply above amps x 2.0. For 208V power supply, multiply above amps x 2.2.

(3) Nominal cooling capacity based on DX coils with 2) 4 Row coils in "A" arrangement, 45° Suction temperature and 80°/67° return air temperature. See CW Coil Data for CW capacities.

(4) Upper number indicates lowest full output and bottom number indicates maximum full output available for each model.

(5) Indicates temperature rise for outputs at CFM shown. Order stainless steel heat exchangers when 30% or more of winter outside air is introduced, or temperature rise at minimum firing rate is below 10°F.

# Performance Table

TAA Air Delivery Table								
TAA Model No. (1)	SCFM	Blowers	Blower Motor - Qty.@ HP/Total Amp Draw (2)		Nominal Cooling Tons (3)	High Fire Output (Minimum)	Air Temperature Rise (5)	
			Standard Arrangement	Alternate Arrangement With Mixing Dampers		High Fire Output (Maximum) (4)		
600 Cooling Only	58,000	3) 27 <sup>1</sup> / <sub>2</sub> " x 27 <sup>1</sup> / <sub>2</sub> "	1 @ 40/52.0	1 @ 40/52.0	114.6	NA	—	—
	61,000		1 @ 40/52.0	1 @ 50/65.0	119.3		—	—
	64,000		1 @ 50/65.0	1 @ 50/65.0	123.6		—	—
	67,000		1 @ 50/65.0	1 @ 50/65.0	132.6		—	—
	70,000		1 @ 60/77.0	1 @ 60/77.0	137.4		—	—
	73,000		1 @ 60/77.0	1 @ 75/96.0	142.1		—	—
	76,000		1 @ 60/77.0	1 @ 75/96.0	144.3		—	—
	79,000		1 @ 75/96.0	1 @ 75/96.0	146.9		—	—
	81,000		1 @ 75/96.0	1 @ 75/96.0	148.0		—	—
600/300	58,000	3) 27 <sup>1</sup> / <sub>2</sub> " x 27 <sup>1</sup> / <sub>2</sub> "	1 @ 40/52.0	1 @ 40/52.0	114.6	2,750,000 3,000,000	44	48
	61,000		1 @ 40/52.0	1 @ 50/65.0	119.3		42	45
	64,000		1 @ 50/65.0	1 @ 50/65.0	123.6		40	43
	67,000		1 @ 50/65.0	1 @ 50/65.0	132.6		38	41
	70,000		1 @ 60/77.0	1 @ 60/77.0	137.4		36	39
	73,000		1 @ 60/77.0	1 @ 75/96.0	142.1		35	38
	76,000		1 @ 60/77.0	1 @ 75/96.0	144.3		33	36
	79,000		1 @ 75/96.0	1 @ 75/96.0	146.9		32	35
	81,000		1 @ 75/96.0	1 @ 75/96.0	148.0		31	34
600/400	58,000	3) 27 <sup>1</sup> / <sub>2</sub> " x 27 <sup>1</sup> / <sub>2</sub> "	1 @ 40/52.0	1 @ 40/52.0	114.6	3,250,000 4,000,000	52	64
	61,000		1 @ 40/52.0	1 @ 50/65.0	119.3		49	60
	64,000		1 @ 50/65.0	1 @ 50/65.0	123.6		47	58
	67,000		1 @ 50/65.0	1 @ 50/65.0	132.6		45	55
	70,000		1 @ 60/77.0	1 @ 60/77.0	137.4		43	53
	73,000		1 @ 60/77.0	1 @ 75/96.0	142.1		41	51
	76,000		1 @ 60/77.0	1 @ 75/96.0	144.3		39	49
	79,000		1 @ 75/96.0	1 @ 75/96.0	146.9		38	47
	81,000		1 @ 75/96.0	1 @ 75/96.0	148.0		37	46

(1) Base unit priced by CFM and matching coil size.

(2) Typical amps shown are based on 460V power supply. For 230V power supply, multiply above amps x 2.0. For 208V power supply, multiply above amps x 2.2.

(3) Nominal cooling capacity based on DX coils with 2) 4 Row coils in "A" arrangement, 45° Suction temperature and 80°/67° return air temperature. See CW Coil Data for CW capacities.

(4) Upper number indicates lowest full output and bottom number indicates maximum full output available for each model.

(5) Indicates temperature rise for outputs at CFM shown. Order stainless steel heat exchangers when 30% or more of winter outside air is introduced, or temperature rise at minimum firing rate is below 10°F.

# Performance Table

TAA Engineering Data							
TAA Model No. (1)	SCFM	High Fire Output (Minimum)	Draft Inducer HP/Amp Draw (3), (4)	Gas Burner HP/Amp Draw (3), (4)	Pipe Size (5)	Minimum Stack Size	V-Bank Filters
		High Fire Output (Maximum) (2)					
175 Cooling Only	13,000	NA	NA	NA	NA	NA	30 20 x 20 x 2
	14,000						
	15,000						
	16,000						
	17,000						
	18,000						
	19,000						
	20,000						
175/75	13,000	650,000 750,000	.50/2.2	.33/2.2	1 1/4"	10"	30 20 x 20 x 2
	14,000						
	15,000						
	16,000						
	17,000						
	18,000						
	19,000						
	20,000						
175/100	13,000	850,000 1,000,000	.50/2.2	.33/2.2	1 1/2"	10"	30 20 x 20 x 2
	14,000						
	15,000						
	16,000						
	17,000						
	18,000						
	19,000						
	20,000						
250 Cooling Only	20,000	NA	NA	NA	NA	NA	36 20 x 20 x 2
	22,000						
	24,000						
	26,000						
	28,000						
	30,000						

(1) Base unit priced by CFM and matching coil size.

(2) Upper number indicates lowest full output and bottom number indicates maximum full output available for each model.

(3) Typical amps shown are based on 460V power supply. For single phase motors, the load is based on control transformer sized to handle burner and/or draft inducer motors.

(4) Typical amps shown are based on 460V power supply. For 230V power supply, multiply above amps x 2.0. For 208V power supply, multiply above amps x 2.2.

(5) Gas pipe size is based on standard manifold with 8" to 14" W.C. gas pressure.

# Performance Table

TAA Engineering Data							
TAA Model No. (1)	SCFM	High Fire Output (Minimum)	Draft Inducer HP/Amp Draw (3), (4)	Gas Burner HP/Amp Draw (3), (4)	Pipe Size (5)	Minimum Stack Size	V-Bank Filters
		High Fire Output (Maximum) (2)					
250/100	20,000	850,000 1,000,000	.50/2.2	.33/2.2	1 1/2"	10"	36 20 x 20 x 2
	22,000						
	24,000						
	26,000						
	28,000						
	30,000						
250/175	20,000	1,250,000 1,750,000	2.0/3.4	.33/3.3	1 1/2" 2"	12"	36 20 x 20 x 2
	22,000						
	24,000						
	26,000						
	28,000						
	30,000						
300 Cooling Only	29,000	NA	NA	NA	NA	NA	49 20 x 20 x 2
	31,000						
	33,000						
	35,000						
	37,000						
	39,000						
300/175	29,000	1,250,000 1,750,000	2.0/3.4	.33/3.3	1 1/2" 2"	12"	49 20 x 20 x 2
	31,000						
	33,000						
	35,000						
	37,000						
	39,000						
300/250	29,000	2,000,000 2,500,000	2.0/3.4 5.0/7.6	.75/1.4 1.5/2.6	2" 2-1/2"	14" 16"	49 20 x 20 x 2
	31,000						
	33,000						
	35,000						
	37,000						
	39,000						

(1) Base unit priced by CFM and matching coil size.

(2) Upper number indicates lowest full output and bottom number indicates maximum full output available for each model.

(3) Typical amps shown are based on 460V power supply. For single phase motors, the load is based on control transformer sized to handle burner and/or draft inducer motors.

(4) Typical amps shown are based on 460V power supply. For 230V power supply, multiply above amps x 2.0. For 208V power supply, multiply above amps x 2.2.

(5) Gas pipe size is based on standard manifold with 8" to 14" W.C. gas pressure.

# Performance Table

TAA Engineering Data							
TAA Model No. (1)	SCFM	High Fire Output (Minimum)	Draft Inducer HP/Amp Draw (3), (4)	Gas Burner HP/Amp Draw (3), (4)	Pipe Size (5)	Minimum Stack Size	V-Bank Filters
		High Fire Output (Maximum) (2)					
400 Cooling Only	37,000	NA	NA	NA	NA	NA	64 20 x 20 x 2
	39,000						
	41,000						
	43,000						
	45,000						
	47,000						
	49,000						
	51,000						
53,000							
400/250	37,000	2,000,000 2,500,000	2.0/3.4 5.0/7.6	.75/1.4 1.5/2.6	2" 2-1/2"	14" 16"	64 20 x 20 x 2
	39,000						
	41,000						
	43,000						
	45,000						
	47,000						
	49,000						
	51,000						
53,000							
400/300	37,000	2,750,000 3,000,000	5.0/7.6	1.5/2.6	2-1/2"	16"	64 20 x 20 x 2
	39,000						
	41,000						
	43,000						
	45,000						
	47,000						
	49,000						
	51,000						
53,000							

(1) Base unit priced by CFM and matching coil size.

(2) Upper number indicates lowest full output and bottom number indicates maximum full output available for each model.

(3) Typical amps shown are based on 460V power supply. For single phase motors, the load is based on control transformer sized to handle burner and/or draft inducer motors.

(4) Typical amps shown are based on 460V power supply. For 230V power supply, multiply above amps x 2.0. For 208V power supply, multiply above amps x 2.2.

(5) Gas pipe size is based on standard manifold with 8" to 14" W.C. gas pressure.

# Performance Table

TAA Engineering Data							
TAA Model No. (1)	SCFM	High Fire Output (Minimum)	Draft Inducer HP/Amp Draw (3), (4)	Gas Burner HP/Amp Draw (3), (4)	Pipe Size (5)	Minimum Stack Size	V-Bank Filters
		High Fire Output (Maximum) (2)					
600 Cooling Only	58,000	NA	NA	NA	NA	NA	90 20 x 25 x 2
	61,000						
	64,000						
	67,000						
	70,000						
	73,000						
	76,000						
	79,000						
600/300	58,000	2,750,000 3,000,000	5.0/7.6	1.5/2.6	2-1/2"	16"	90 20 x 25 x 2
	61,000						
	64,000						
	67,000						
	70,000						
	73,000						
	76,000						
	79,000						
600/400	58,000	3,250,000 4,000,000	5.0/7.6	1.5/2.6 3.0/4.8	2-1/2" 3"	16"	90 20 x 25 x 2
	61,000						
	64,000						
	67,000						
	70,000						
	73,000						
	76,000						
	79,000						
81,000							

(1) Base unit priced by CFM and matching coil size.

(2) Upper number indicates lowest full output and bottom number indicates maximum full output available for each model.

(3) Typical amps shown are based on 460V power supply. For single phase motors, the load is based on control transformer sized to handle burner and/or draft inducer motors.

(4) Typical amps shown are based on 460V power supply. For 230V power supply, multiply above amps x 2.0. For 208V power supply, multiply above amps x 2.2.

(5) Gas pipe size is based on standard manifold with 8" to 14" W.C. gas pressure.

# Performance Table

DX Coil Data								
TAC & TAA Model No. (1)	SCFM	Nominal Cooling Tons (2)	Coil Size Fin Height x Fin Length	Rows Deep/FPI	Face Velocity (FPM)	Air Pressure Drop ("W.C.)	Total MBH	Sensible MBH
175	13,000	26.8	2) 24" x 88"	4/6	443	0.29	321.91	239.18
	14,000	28.4			477	0.34	340.81	253.91
	15,000	29.9			511	0.39	359.24	268.36
	16,000	33.1	2) 30" x 88"	4/6	436	0.28	397.58	295.24
	17,000	34.7			464	0.32	416.66	310.09
	18,000	36.3			491	0.36	435.20	324.63
	19,000	38.7	2) 33" x 88"	4/6	471	0.33	463.95	345.49
	20,000	40.2			496	0.36	482.80	360.13
250	20,000	42.2	2) 30" x 108"	4/5	444	0.25	505.93	359.82
	22,000	45.0	2) 36" x 108"	4/5	489	0.31	540.32	386.42
	24,000	50.6			444	0.25	607.12	431.78
	26,000	53.5			481	0.30	641.66	458.48
	28,000	57.7	2) 39" x 108"	4/5	479	0.29	692.32	494.50
	30,000	60.5			513	0.34	725.53	520.43
300	29,000	58.1	2) 36" x 128"	4/6	453	0.30	697.37	524.77
	31,000	61.3	2) 39" x 128"	4/6	484	0.35	735.95	554.47
	33,000	65.8			476	0.34	789.66	593.42
	35,000	68.5			505	0.38	822.28	620.71
	37,000	73.8	2) 45" x 128"	4/6	463	0.32	885.60	666.90
	39,000	77.0			488	0.35	924.41	696.65
400	37,000	75.4	2) 42" x 148"	4/5	429	0.23	904.84	655.47
	39,000	78.6			452	0.26	942.98	683.75
	41,000	81.3			475	0.29	975.20	709.54
	43,000	87.2	2) 48" x 148"	4/5	436	0.24	1046.65	758.81
	45,000	90.3			456	0.26	1083.40	786.49
	47,000	93.1			476	0.29	1116.92	812.79
	49,000	99.0	2) 54" x 148"	4/5	441	0.25	1188.16	862.02
	51,000	102.1			459	0.27	1224.94	889.69
53,000	104.9	477			0.29	1258.63	916.02	
600	58,000	114.6	2) 54" x 168"	4/6	460	0.41	1390.40	1140.00
	61,000	119.3			484	0.44	1428.30	1163.70
	64,000	123.6			508	0.48	1461.70	1220.90
	67,000	132.6	2) 63" x 168"	4/6	456	0.40	1601.20	1313.00
	70,000	137.4			476	0.43	1638.20	1331.40
	73,000	142.1			497	0.46	1674.70	1388.50
	76,000	144.3			517	0.49	1711.20	1445.50
	79,000	146.9			537	0.53	1743.00	1457.10
	81,000	148.0			550	0.55	1765.30	1494.17

(1) Base unit priced by CFM and matching coil size.

(2) Nominal cooling capacity based on 2) 4 Row DX coils in "A" arrangement, with 45° Suction temperature, and 80°/67° return air temperature.

# Performance Table

CW Coil Data												
TAC & TAA Model No. (1)	SCFM	Nominal Cooling Tons (2)	Coil Size Fin Height x Fin Length	Rows Deep/FPI	Face Velocity (FPM)	Air Pressure Drop ("W.C.)	Total MBH	Sensible MBH	GPM	FPD (ft)		
175	13,000	27.6	2) 24" x 88"	4/6	443	0.29	331.76	242.96	73.6	3.13		
	14,000	28.9			477	0.34	347.18	256.36	77.0	3.39		
	15,000	30.2			511	0.39	361.98	269.41	80.4	3.65		
	16,000	34.2			2) 30" x 88"	4/6	436	0.28	410.74	300.31	91.2	3.08
	17,000	35.5	464	0.32			426.37	313.81	94.6	3.29		
	18,000	36.8	491	0.36			441.45	327.02	98.0	3.49		
	19,000	39.5	2) 33" x 88"	4/6			471	0.33	473.58	349.18	105.0	3.34
	20,000	40.7			496	0.36	488.57	362.32	108.4	3.53		
250	20,000	44.4	2) 30" x 108"	4/6	444	0.29	532.84	382.43	118.2	5.41		
	22,000	47.1			489	0.35	565.13	409.68	125.4	6.00		
	24,000	53.3	2) 36" x 108"	4/6	444	0.29	639.41	458.93	141.8	5.41		
	26,000	56.0			481	0.34	671.83	486.25	149.0	5.90		
	28,000	60.4			2) 39" x 108"	4/6	479	0.34	725.18	524.52	161.0	5.86
	30,000	63.0					513	0.39	756.36	551.14	167.8	6.32
300	29,000	59.8	2) 36" x 128"	4/5	453	0.26	717.14	514.49	159.2	7.28		
	31,000	62.2			484	0.30	746.51	539.15	165.6	7.81		
	33,000	66.7	2) 39" x 128"	4/5	476	0.29	800.28	576.95	177.6	7.67		
	35,000	69.1			505	0.33	828.90	601.16	184.0	8.16		
	37,000	75.6			2) 45" x 128"	4/5	463	0.27	907.60	652.45	201.4	7.44
	39,000	78.1					488	0.31	936.74	676.96	207.8	7.86
400	37,000	79.7	2) 42" x 148"	4/5	429	0.23	956.68	675.74	212.2	10.04		
	39,000	82.3			452	0.26	988.04	701.33	219.2	10.63		
	41,000	84.9			2) 48" x 148"	4/5	475	0.29	1018.49	726.41	226.0	11.21
	43,000	92.1					436	0.24	1104.66	781.49	245.2	10.22
	45,000	94.7	456	0.26			1135.80	806.94	252.0	10.74		
	47,000	97.2	476	0.29			1166.13	831.94	258.8	11.24		
	49,000	104.4	2) 54" x 148"	4/5	441	0.25	1252.57	887.18	278.0	10.37		
	51,000	107.0			459	0.27	1283.53	912.53	284.8	10.82		
53,000	109.5	477			0.29	1313.77	937.49	291.4	11.27			
600	58,000	109.2			2) 54" x 168"	4/5	460	0.38	1310.70	1040.53	260.0	10.51
	61,000	112.9	484	0.41			1354.33	1076.12	270.0	11.28		
	64,000	115.9	2) 63" x 168"	4/5			508	0.45	1391.14	1109.90	280.0	12.04
	67,000	125.8					456	0.37	1510.06	1202.00	295.0	10.71
	70,000	128.7			476	0.40	1544.03	1234.89	302.0	11.17		
	73,000	132.0			497	0.43	1584.59	1265.98	312.0	11.86		
	76,000	135.2	517	0.46	1621.85	1318.01	322.0	12.57				
	79,000	139.2	537	0.50	1670.21	1346.42	332.0	13.30				
81,000	140.4	550	0.52	1685.12	1380.50	338.0	13.76					

(1) Base unit priced by CFM and matching coil size

(2) Nominal cooling capacity based on 2) 4 Row CW coils in "A" arrangement, with 45° EWT, 55° LWT, and 80°/67° return air temperature.

# Performance Table

TAJ Air Delivery Table							
<i>Propeller Models – Heating Only</i>							
TAJ Model	SCFM	Prop Fan Qty) Pitch/Size	Fan Motors - Qty.@ HP/Total Amp Draw		Burner Output	Air Temperature Rise	
			Single Phase (1)	Three Phase (2)			
Single	5,500	1) 7/24	1 @ .5/4.9	1 @ .5/1.1	160,000	27	42
	6,050	1) 11/24	1 @ .75/6.9	1 @ .75/1.6	250,000	24	38
Double	11,000	2) 7/24	2 @ .5/9.8	2 @ .5/2.2	320,000	27	42
	12,100	2) 11/24	2 @ .75/13.8	2 @ .75/3.2	500,000	24	38
<i>Blower Models – Heating Only</i>							
TAJ Model	SCFM	Blower Qty) Size	Fan Motors - Qty.@ HP/Total Amp Draw		Burner Output	Air Temperature Rise	
			Single Phase (1)	Three Phase (2)			
Single	4,000	1) 15" x 15"	1 @ 1-1/2/10.0	1 @ 1-1/2/3.0	160,000 250,000	37	58
	4,500		1 @ 1-1/2/10.0	1 @ 1-1/2/3.0		33	51
	5,000		1 @ 1-1/2/10.0	1 @ 1-1/2/3.0		29	46
	5,500		1 @ 1-1/2/10.0	1 @ 1-1/2/3.0		27	42
	6,000		1 @ 2/12.0	1 @ 2/3.4		25	38
Double	8,000	2) 15" x 15"	2 @ 1-1/2/20.0	2 @ 1-1/2/6.0	320,000 500,000	37	58
	9,000		2 @ 1-1/2/20.0	2 @ 1-1/2/6.0		33	51
	10,000		2 @ 1-1/2/20.0	2 @ 1-1/2/6.0		29	46
	11,000		2 @ 1-1/2/20.0	2 @ 1-1/2/6.0		27	42
	12,000		2 @ 2/24.0	2 @ 2/6.8		25	38
<i>Blower Models – Heating and Cooling</i>							
TAJ Model	SCFM	Blower Qty) Size	Fan Motors - Qty.@ HP/Total Amp Draw		Burner Output	Air Temperature Rise	
			Single Phase (1)	Three Phase (2)			
Single	4,000	1) 15" x 15"	1 @ 1-1/2/10.0	1 @ 1-1/2/3.0	160,000 250,000	37	58
	4,500		1 @ 1-1/2/10.0	1 @ 1-1/2/3.0		33	51
	5,000		1 @ 1-1/2/10.0	1 @ 1-1/2/3.0		29	46
	5,500		1 @ 2/12.0	1 @ 2/3.4		27	42
	6,000		1 @ 2/12.0	1 @ 2/3.4		25	38
Double	8,000	2) 15" x 15"	2 @ 1-1/2/20.0	2 @ 1-1/2/6.0	320,000 500,000	37	58
	9,000		2 @ 1-1/2/20.0	2 @ 1-1/2/6.0		33	51
	10,000		2 @ 1-1/2/20.0	2 @ 1-1/2/6.0		29	46
	11,000		2 @ 2/24.0	2 @ 2/6.8		27	42
	12,000		2 @ 2/24.0	2 @ 2/6.8		25	38

**NOTES:**

1. Typical amps shown are based on 230V power supply. For 115V power supply, multiply above amps times 2.0.
2. Typical amps shown are based on 460V power supply. For 230V power supply, multiply above amps times 2.0. For 200V power supply, multiply above amps times 2.2.

**3. TAJ not approved for installations in Canada.**

# Performance Table

TAJ Engineering Data							
<b>Propeller Models</b>							
TAJ Model	SCFM	Burner Output	Optional Draft Inducer - Qty.@ WATTS/Amp Draw Total (1)	Gas Burner - Qty.@ HP/Amp Draw Total (1)	Pipe Size (2)	Minimum Stack Diameter	Flat Bank Filters
Single	5,500	160,000	1 @ 32/0.43	1 @ 1/7/2.4	1 @ 3/4"	1 @ 8"	4) 20" x 28" x 1"
	6,050	250,000					
Double	11,000	320,000	2 @ 32/0.86	2 @ 1/7/4.8	2 @ 3/4"	2 @ 8"	6) 20" x 28" x 1"
	12,100	500,000					
<b>Blower Models</b>							
TAJ Model	SCFM	Burner Output	Optional Draft Inducer - Qty.@ WATTS/Amp Draw Total (1)	Gas Burner - Qty.@ HP/Amp Draw Total (1)	Pipe Size (2)	Minimum Stack Diameter	Flat Bank Filters
Single	4,000	160,000 250,000	1 @ 32/0.43	1 @ 1/7/2.4	1 @ 3/4"	1 @ 8"	4) 20" x 28" x 1"
	4,500						
	5,000						
	5,500						
	6,000						
Double	8,000	320,000 500,000	2 @ 32/0.86	2 @ 1/7/4.8	2 @ 3/4"	2 @ 8"	6) 20" x 28" x 1"
	9,000						
	10,000						
	11,000						
	12,000						

(1) Typical amps shown are based on standard 115V motor(s).

(2) Gas pipe size is based on natural gas or propane with 7" to 14" W.C. inlet pressure.

**(3) TAJ not approved for installations in Canada.**

# Performance Table

DX Coil Data								
TAJ Model No.	SCFM	Nominal Cooling Ton (1)	Coil Size Fin Height x Fin Length	Rows Deep/FPI	Face Velocity (FPM)	Air Pressure Drop ("W.C.)	Total MBH	Sensible MBH
Single	4,000	9.5	2) 30" x 30"	3/9	320	0.17	114.50	78.8
	4,500	10.2			360	0.21	122.90	85.5
	5,000	10.8			400	0.23	129.70	91.5
	5,500	11.4			440	0.27	136.40	97.3
	6,000	11.9			480	0.32	142.60	102.9
Double	8,000	19.0	4) 30" x 30"	3/9	320	0.17	229.0	157.6
	9,000	20.4			360	0.21	245.8	171.0
	10,000	21.6			400	0.23	259.4	183.0
	11,000	22.8			440	0.27	272.8	194.6
	12,000	23.8			480	0.32	285.2	205.8

(1) Nominal cooling capacity based on 2) DX coils in "A" arrangement, with 45° Suction temperature, and 80°/67° return air temperature.

**(3) TAJ not approved for installations in Canada.**

CW Coil Data										
TAJ Model No.	SCFM	Nominal Cooling Ton (2)	Coil Size Fin Height x Fin Length	Rows Deep/FPI	Face Velocity (FPM)	Air Pressure Drop ("W.C.)	Total MBH	Sensible MBH	GPM	FPD (ft)
Single	4,000	7.7	2) 30" x 30"	3/9	320	0.16	92.9	72.20	20.6	2.24
	4,500	8.3			360	0.20	99.6	78.60	22.1	2.56
	5,000	8.8			400	0.23	105.9	84.70	23.5	2.89
	5,500	9.3			440	0.26	111.9	90.60	24.8	3.22
	6,000	9.8			480	0.31	117.7	96.40	26.1	3.55
Double	8,000	15.5	4) 30" x 30"	3/9	320	0.16	185.8	144.4	41.2	2.24
	9,000	16.6			360	0.20	199.2	157.2	44.2	2.56
	10,000	17.7			400	0.23	211.8	169.4	47.0	2.89
	11,000	18.7			440	0.26	223.8	181.2	49.6	3.22
	12,000	19.6			480	0.31	235.4	192.8	52.2	3.55

(2) Nominal cooling capacity based on 2) CW coils in "A" arrangement, with 45° EWT, 55° LWT, and 80°/67° return air temperature.

**(3) TAJ not approved for installations in Canada.**

# Dimensions

## Basic Unit

C000518

### TAP-75/40 Through TAP-600S/600

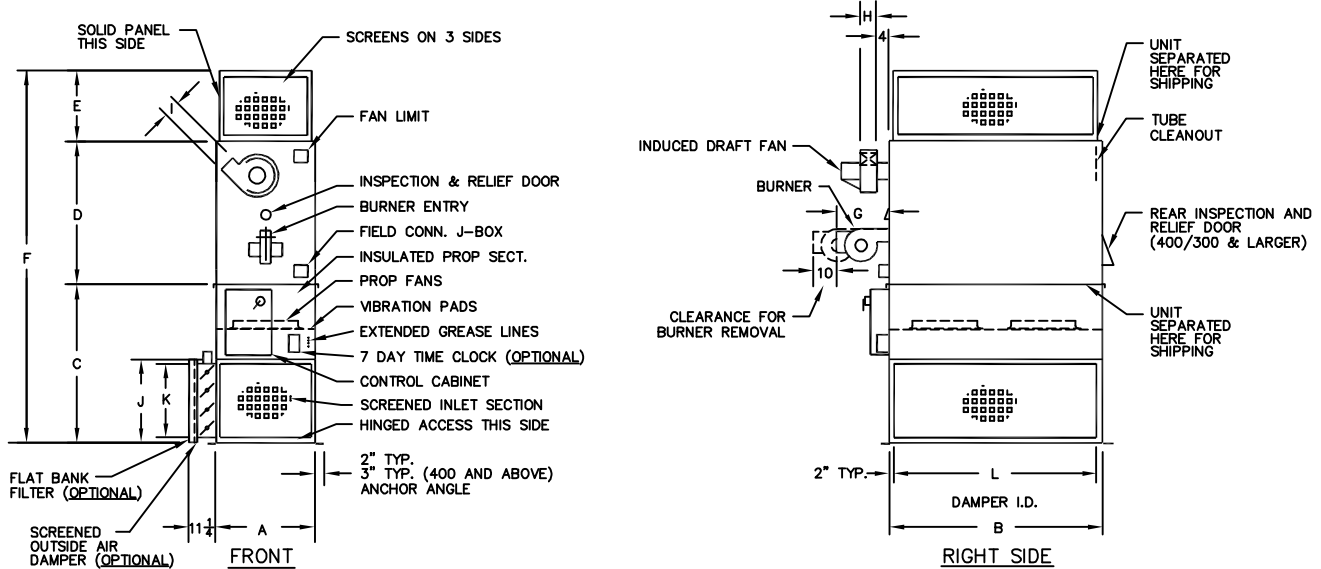

**NOTE:** On units 200 and above discharge section is shipped knocked down (field assembly by others).

Model No.	Approx. Weight	DIMENSIONS												Outside Air Filters Qty) Size
		A	B	C	D	E	F	G	H	I	J	K	L	
75/40	2,315	36	80	72	47	30	149	17	6 <sup>3</sup> / <sub>8</sub>	6 <sup>1</sup> / <sub>4</sub>	36	32	76	6) 16 x 25 x 2
75/55	2,490	36	80	72	55	30	157	17	6 <sup>3</sup> / <sub>8</sub>	6 <sup>1</sup> / <sub>4</sub>	36	32	76	6) 16 x 25 x 2
100/55	2,910	48	90	72	55	30	157	17	6 <sup>3</sup> / <sub>8</sub>	6 <sup>1</sup> / <sub>4</sub>	36	32	86	8) 16 x 20 x 2
100/75	3,055	48	90	72	55	30	157	17	7 <sup>3</sup> / <sub>8</sub>	7	36	32	86	8) 16 x 20 x 2
125/75	3,510	54	100	62	55	30	147	17	7 <sup>3</sup> / <sub>8</sub>	7	30 <sup>1</sup> / <sub>2</sub>	26 <sup>1</sup> / <sub>2</sub>	96	8) 16 x 25 x 2
125/100	3,850	54	100	62	68	30	160	17	7 <sup>3</sup> / <sub>8</sub>	7	30 <sup>1</sup> / <sub>2</sub>	26 <sup>1</sup> / <sub>2</sub>	96	8) 16 x 25 x 2
175/75	3,615	54	100	62	55	30	147	17	7 <sup>3</sup> / <sub>8</sub>	7	30 <sup>1</sup> / <sub>2</sub>	26 <sup>1</sup> / <sub>2</sub>	96	8) 16 x 25 x 2
175/100	3,950	54	100	62	68	30	160	17	7 <sup>3</sup> / <sub>8</sub>	7	30 <sup>1</sup> / <sub>2</sub>	26 <sup>1</sup> / <sub>2</sub>	96	8) 16 x 25 x 2
200/100	4,680	60	120	78	68	48	194	17	7 <sup>3</sup> / <sub>8</sub>	7	44	40	116	12) 20 x 20 x 2
200/175	5,040	60	120	78	72	48	198	21	9 <sup>3</sup> / <sub>8</sub>	9	44	40	116	12) 20 x 20 x 2
250/100	4,825	60	120	78	68	48	194	17	7 <sup>3</sup> / <sub>8</sub>	7	44	40	116	12) 20 x 20 x 2
250/175	5,185	60	120	78	72	48	198	21	9 <sup>3</sup> / <sub>8</sub>	9	44	40	116	12) 20 x 20 x 2
300/175	6,005	65	140	84	72	48	204	21	9 <sup>3</sup> / <sub>8</sub>	9	52	48	136	14) 20 x 25 x 2
300/200	6,475	65	140	84	72	48	204	30	9 <sup>3</sup> / <sub>8</sub>	9	52	48	136	14) 20 x 25 x 2
300/250	6,840	65	140	84	72	48	204	26	11 <sup>1</sup> / <sub>8</sub>	10 <sup>5</sup> / <sub>8</sub>	52	48	136	14) 20 x 25 x 2
400/200	8,385	70	160	92	72	48	212	30	9 <sup>3</sup> / <sub>8</sub>	9	52	48	156	16) 20 x 25 x 2
400/250	8,655	70	160	92	72	48	212	26	11 <sup>1</sup> / <sub>8</sub>	10 <sup>5</sup> / <sub>8</sub>	52	48	156	16) 20 x 25 x 2
400/300	8,945	70	160	92	84	48	224	26	11 <sup>1</sup> / <sub>8</sub>	10 <sup>5</sup> / <sub>8</sub>	52	48	156	16) 20 x 25 x 2
600/300	10,745	80	180	96	84	60	240	26	11 <sup>1</sup> / <sub>8</sub>	10 <sup>5</sup> / <sub>8</sub>	54	50	176	18) 20 x 25 x 2
600/400	11,170	80	180	96	100	60	256	32	11 <sup>1</sup> / <sub>8</sub>	10 <sup>5</sup> / <sub>8</sub>	54	50	176	18) 20 x 25 x 2
600S/400	13,080	85	200	102	100	60	262	32	11 <sup>1</sup> / <sub>8</sub>	10 <sup>5</sup> / <sub>8</sub>	60	56	196	24) 20 x 25 x 2
600S/600	15,980	85	200	102	141	60	303	32	11 <sup>1</sup> / <sub>8</sub>	10 <sup>5</sup> / <sub>8</sub>	60	56	196	24) 20 x 25 x 2

# Dimensions

## Basic Unit

TAP-S0178

### TAP-600SS/400 Through TAP-600SS/600

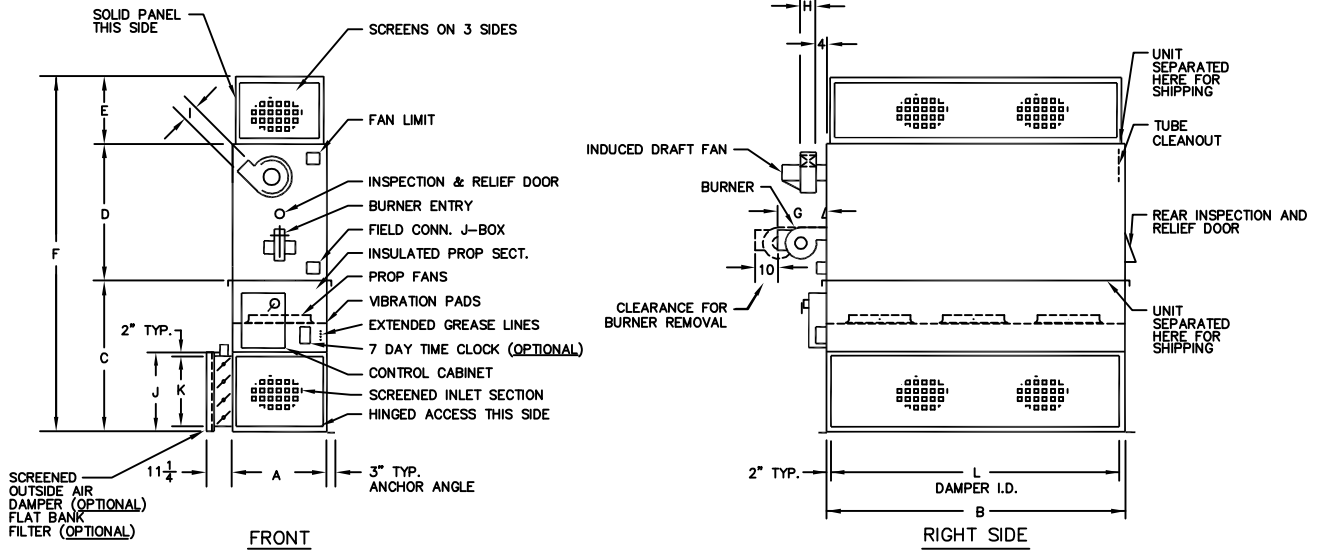

**NOTE:** Discharge section is shipped knocked down (field assembly by others).

Model No.	Approx. Weight	DIMENSIONS												Outside Air Filters Qty) Size
		A	B	C	D	E	F	G	H	I	J	K	L	
600SS/400	16,235	85	210	102	100	60	262	32	11 <sup>1</sup> / <sub>8</sub>	10 <sup>5</sup> / <sub>8</sub>	60	56	206	42) 15 x 20 x 2
600SS/600	18,225	85	210	102	141	60	303	32	11 <sup>1</sup> / <sub>8</sub>	10 <sup>5</sup> / <sub>8</sub>	60	56	206	42) 15 x 20 x 2

# Dimensions

## Basic Unit with Outside Air and Return Air Dampers

C000520

### TAP-75/40 Through TAP-600S/600

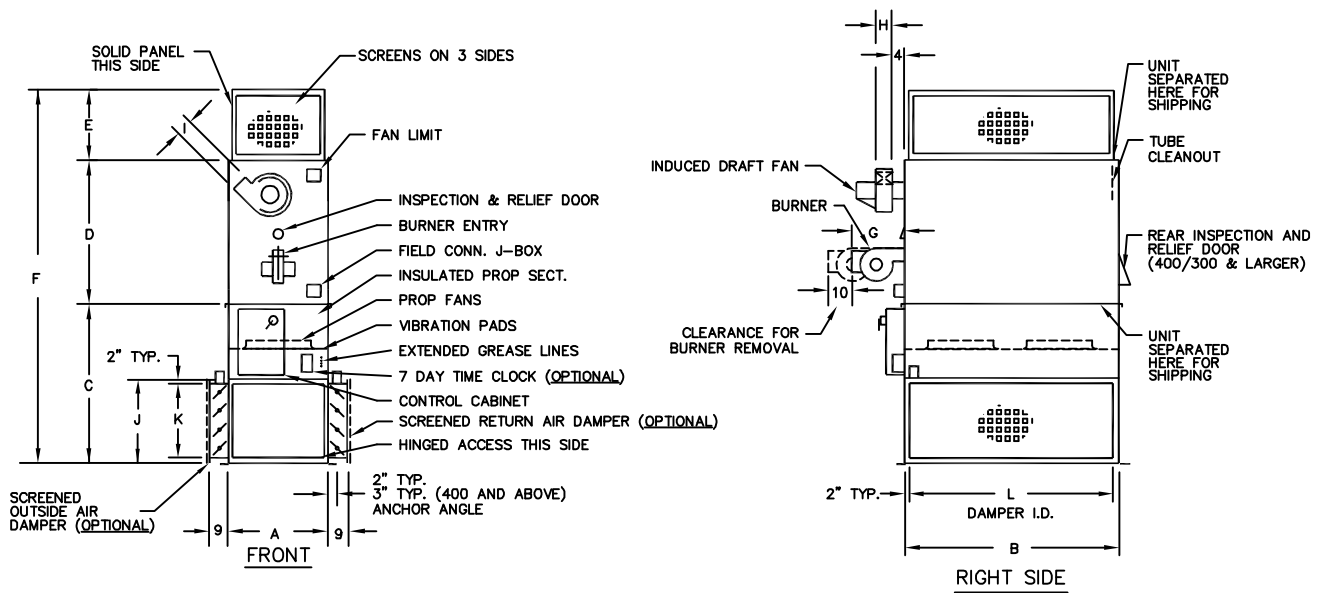

**NOTE:** On units 200 and above discharge section is shipped knocked down (field assembly by others).

Model No.	Approx. Weight	DIMENSIONS											
		A	B	C	D	E	F	G	H	I	J	K	L
75/40	2,460	36	80	72	47	30	149	17	6 <sup>3</sup> / <sub>8</sub>	6 <sup>1</sup> / <sub>4</sub>	36	32	76
75/55	2,635	36	80	72	55	30	157	17	6 <sup>3</sup> / <sub>8</sub>	6 <sup>1</sup> / <sub>4</sub>	36	32	76
100/55	3,060	48	90	84	55	30	169	17	6 <sup>3</sup> / <sub>8</sub>	6 <sup>1</sup> / <sub>4</sub>	48	44	86
100/75	3,205	48	90	84	55	30	169	17	7 <sup>3</sup> / <sub>8</sub>	7	48	44	86
125/75	3,735	54	100	85 <sup>1</sup> / <sub>2</sub>	55	30	170 <sup>1</sup> / <sub>2</sub>	17	7 <sup>3</sup> / <sub>8</sub>	7	54	50	96
125/100	4,070	54	100	85 <sup>1</sup> / <sub>2</sub>	68	30	183 <sup>1</sup> / <sub>2</sub>	17	7 <sup>3</sup> / <sub>8</sub>	7	54	50	96
175/75	3,835	54	100	85 <sup>1</sup> / <sub>2</sub>	55	30	170 <sup>1</sup> / <sub>2</sub>	17	7 <sup>3</sup> / <sub>8</sub>	7	54	50	96
175/100	4,175	54	100	85 <sup>1</sup> / <sub>2</sub>	68	30	183 <sup>1</sup> / <sub>2</sub>	17	7 <sup>3</sup> / <sub>8</sub>	7	54	50	96
200/100	4,940	60	120	94	68	48	210	17	7 <sup>3</sup> / <sub>8</sub>	7	60	56	116
200/175	5,295	60	120	94	72	48	214	21	9 <sup>3</sup> / <sub>8</sub>	9	60	56	116
250/100	5,085	60	120	94	68	48	210	17	7 <sup>3</sup> / <sub>8</sub>	7	60	56	116
250/175	5,440	60	120	94	72	48	214	21	9 <sup>3</sup> / <sub>8</sub>	9	60	56	116
300/175	6,305	65	140	97	72	48	217	21	9 <sup>3</sup> / <sub>8</sub>	9	65	61	136
300/200	6,775	65	140	97	72	48	217	30	9 <sup>3</sup> / <sub>8</sub>	9	65	61	136
300/250	7,140	65	140	97	72	48	217	26	11 <sup>1</sup> / <sub>8</sub>	10 <sup>5</sup> / <sub>8</sub>	65	61	136
400/200	8,775	70	160	112	72	48	232	30	9 <sup>3</sup> / <sub>8</sub>	9	70	66	156
400/250	9,045	70	160	112	72	48	232	26	11 <sup>1</sup> / <sub>8</sub>	10 <sup>5</sup> / <sub>8</sub>	70	66	156
400/300	9,335	70	160	112	84	48	244	26	11 <sup>1</sup> / <sub>8</sub>	10 <sup>5</sup> / <sub>8</sub>	70	66	156
600/300	11,315	80	180	122	84	60	266	26	11 <sup>1</sup> / <sub>8</sub>	10 <sup>5</sup> / <sub>8</sub>	80	76	176
600/400	11,745	80	180	122	100	60	282	32	11 <sup>1</sup> / <sub>8</sub>	10 <sup>5</sup> / <sub>8</sub>	80	76	176
600S/400	13,750	85	200	127	100	60	287	32	11 <sup>1</sup> / <sub>8</sub>	10 <sup>5</sup> / <sub>8</sub>	85	81	196
600S/600	16,650	85	200	127	141	60	328	32	11 <sup>1</sup> / <sub>8</sub>	10 <sup>5</sup> / <sub>8</sub>	85	81	196

# Dimensions

## Basic Unit with Outside Air and Return Air Dampers

TAP-S0180

### TAP-600SS/400 Through TAP-600SS/600

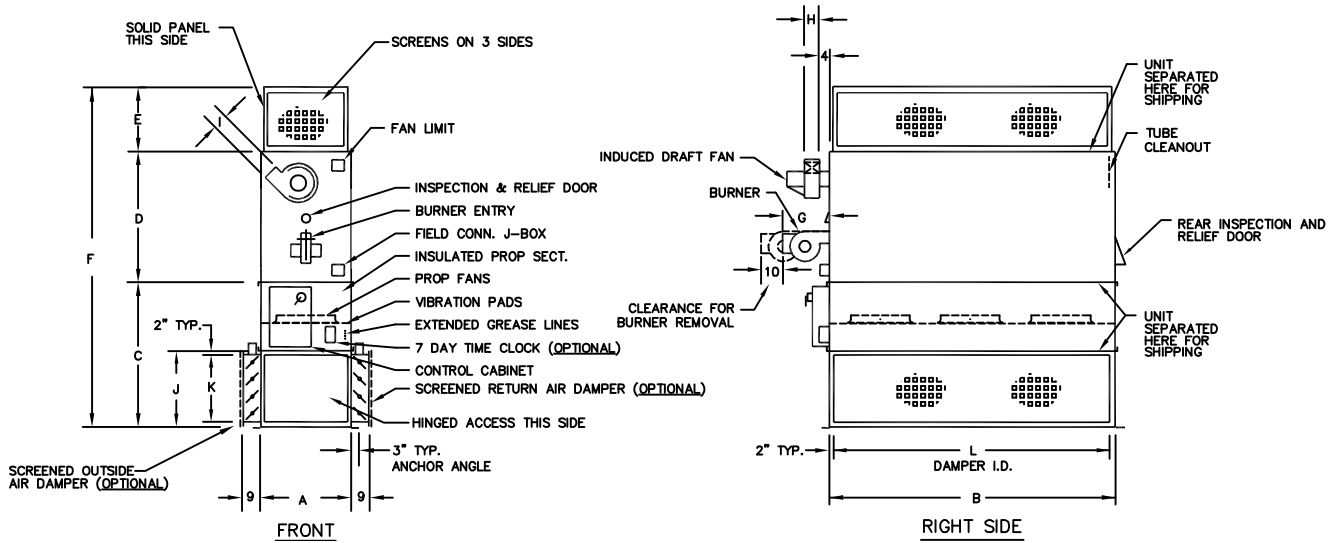

**NOTE:** Discharge section is shipped knocked down (field assembly by others).

Model No.	Approx. Weight	DIMENSIONS											
		A	B	C	D	E	F	G	H	I	J	K	L
600SS/400	17,375	85	210	156	100	60	316	32	11 <sup>1</sup> / <sub>8</sub>	10 <sup>5</sup> / <sub>8</sub>	114	110	206
600SS/600	19,365	85	210	156	141	60	357	32	11 <sup>1</sup> / <sub>8</sub>	10 <sup>5</sup> / <sub>8</sub>	114	110	206

# Dimensions

## Basic Unit with Outside Air and Return Air Dampers and V-Bank Filter Section

C000519

### TAP-75/40 Through TAP-600S/600

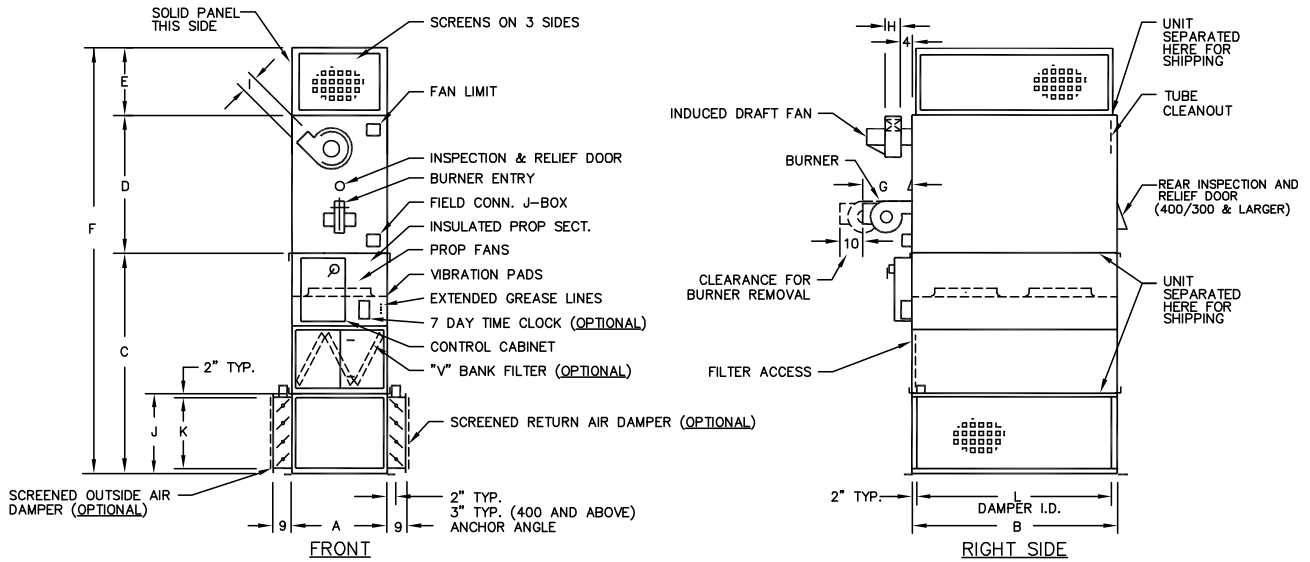

**NOTE:** On units 200 and above discharge section is shipped knocked down (field assembly by others).

Model No.	Approx. Weight	DIMENSIONS												Filters Qty) Size
		A	B	C	D	E	F	G	H	I	J	K	L	
75/40	2,660	36	80	98	47	30	175	17	6 <sup>3</sup> / <sub>8</sub>	6 <sup>1</sup> / <sub>4</sub>	36	32	76	12) 20 x 20 x 2
75/55	2,835	36	80	98	55	30	183	17	6 <sup>3</sup> / <sub>8</sub>	6 <sup>1</sup> / <sub>4</sub>	36	32	76	12) 20 x 20 x 2
100/55	3,280	48	90	110	55	30	195	17	6 <sup>3</sup> / <sub>8</sub>	6 <sup>1</sup> / <sub>4</sub>	48	44	86	16) 20 x 20 x 2
100/75	3,425	48	90	110	55	30	195	17	7 <sup>3</sup> / <sub>8</sub>	7	48	44	86	16) 20 x 20 x 2
125/75	3,975	54	100	111 <sup>1</sup> / <sub>2</sub>	55	30	196 <sup>1</sup> / <sub>2</sub>	17	7 <sup>3</sup> / <sub>8</sub>	7	54	50	96	30) 20 x 20 x 2
125/100	4,315	54	100	111 <sup>1</sup> / <sub>2</sub>	68	30	209 <sup>1</sup> / <sub>2</sub>	17	7 <sup>3</sup> / <sub>8</sub>	7	54	50	96	30) 20 x 20 x 2
175/75	4,080	54	100	111 <sup>1</sup> / <sub>2</sub>	55	30	196 <sup>1</sup> / <sub>2</sub>	17	7 <sup>3</sup> / <sub>8</sub>	7	54	50	96	30) 20 x 20 x 2
175/100	4,415	54	100	111 <sup>1</sup> / <sub>2</sub>	68	30	209 <sup>1</sup> / <sub>2</sub>	17	7 <sup>3</sup> / <sub>8</sub>	7	54	50	96	30) 20 x 20 x 2
200/100	5,205	60	120	120	68	48	236	17	7 <sup>3</sup> / <sub>8</sub>	7	60	56	116	36) 20 x 20 x 2
200/175	5,560	60	120	120	72	48	240	21	9 <sup>3</sup> / <sub>8</sub>	9	60	56	116	36) 20 x 20 x 2
250/100	5,350	60	120	120	68	48	236	17	7 <sup>3</sup> / <sub>8</sub>	7	60	56	116	36) 20 x 20 x 2
250/175	5,705	60	120	120	72	48	240	21	9 <sup>3</sup> / <sub>8</sub>	9	60	56	116	36) 20 x 20 x 2
300/175	6,600	65	140	123	72	48	243	21	9 <sup>3</sup> / <sub>8</sub>	9	65	61	136	49) 20 x 20 x 2
300/200	7,070	65	140	123	72	48	243	30	9 <sup>3</sup> / <sub>8</sub>	9	65	61	136	49) 20 x 20 x 2
300/250	7,435	65	140	123	72	48	243	26	11 <sup>1</sup> / <sub>8</sub>	10 <sup>5</sup> / <sub>8</sub>	65	61	136	49) 20 x 20 x 2
400/200	9,095	70	160	136	72	48	256	30	9 <sup>3</sup> / <sub>8</sub>	9	70	66	156	64) 20 x 20 x 2
400/250	9,370	70	160	136	72	48	256	26	11 <sup>1</sup> / <sub>8</sub>	10 <sup>5</sup> / <sub>8</sub>	70	66	156	64) 20 x 20 x 2
400/300	9,655	70	160	136	84	48	268	26	11 <sup>1</sup> / <sub>8</sub>	10 <sup>5</sup> / <sub>8</sub>	70	66	156	64) 20 x 20 x 2
600/300	11,700	80	180	153	84	60	297	26	11 <sup>1</sup> / <sub>8</sub>	10 <sup>5</sup> / <sub>8</sub>	80	76	176	90) 20 x 25 x 2
600/400	12,130	80	180	153	100	60	313	32	11 <sup>1</sup> / <sub>8</sub>	10 <sup>5</sup> / <sub>8</sub>	80	76	176	90) 20 x 25 x 2
600S/400	14,215	85	200	158	100	60	318	32	11 <sup>1</sup> / <sub>8</sub>	10 <sup>5</sup> / <sub>8</sub>	85	81	196	100) 20 x 25 x 2
600S/600	17,115	85	200	158	141	60	359	32	11 <sup>1</sup> / <sub>8</sub>	10 <sup>5</sup> / <sub>8</sub>	85	81	196	100) 20 x 25 x 2

# Dimensions

## Basic Unit with Outside Air and Return Air Dampers and V-Bank Filter Section

TAP-S0181

### TAP-600SS/400 Through TAP-600SS/600

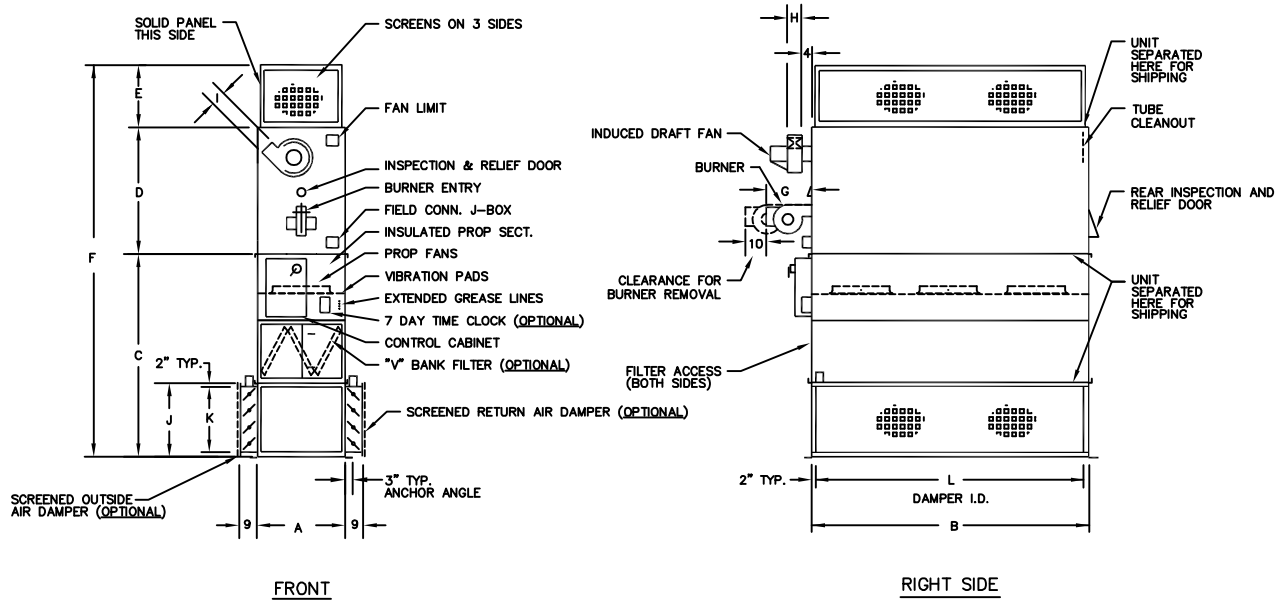

**NOTE:** Discharge section is shipped knocked down (field assembly by others).

Model No.	Approx. Weight	DIMENSIONS												Filters Qty) Size
		A	B	C	D	E	F	G	H	I	J	K	L	
600SS/400	17,930	85	210	187	100	60	347	32	11 <sup>1</sup> / <sub>8</sub>	10 <sup>5</sup> / <sub>8</sub>	114	110	206	100) 20 x 25 x 2
600SS/600	19,920	85	210	187	141	60	388	32	11 <sup>1</sup> / <sub>8</sub>	10 <sup>5</sup> / <sub>8</sub>	114	110	206	100) 20 x 25 x 2

# Dimensions

## Basic Unit

TAS-S0106

### TAS-75 Through TAS-600S

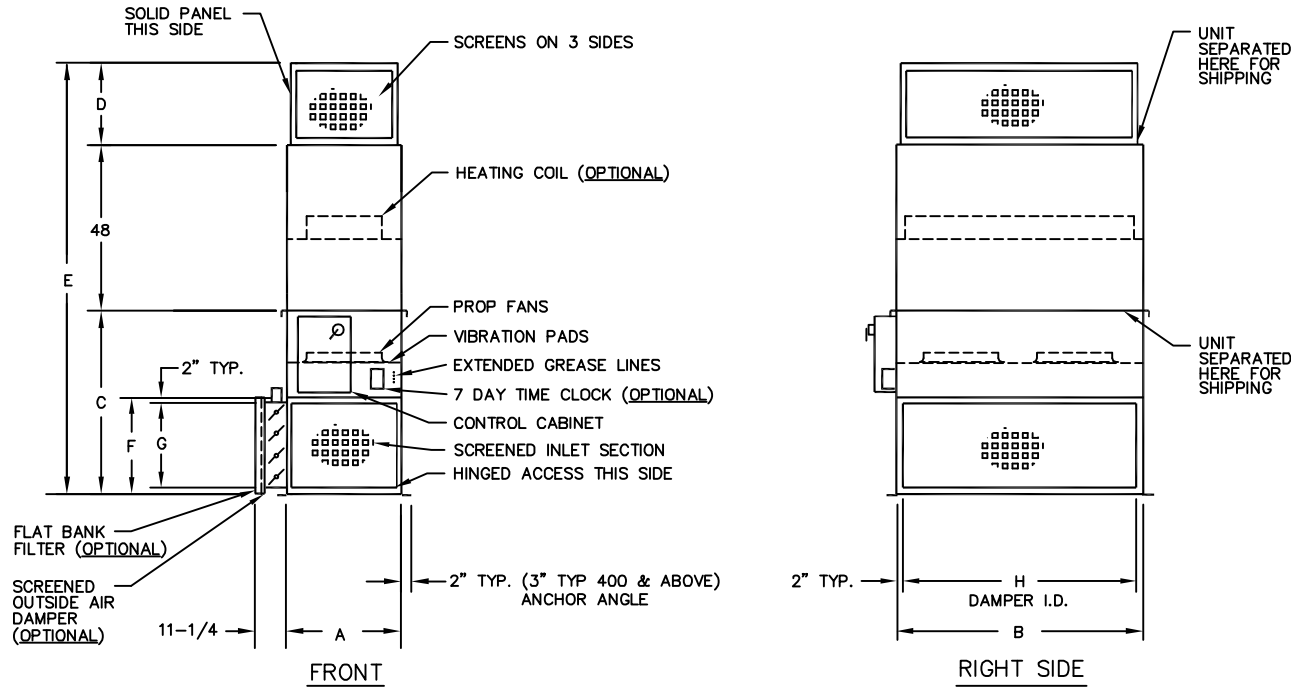

**NOTE:** On units 200 and above discharge section is shipped knocked down (field assembly by others).

Model No.	Approx. Weight	DIMENSIONS								Filters Qty) Size
		A	B	C	D	E	F	G	H	
75	1,360	36	80	72	30	150	36	32	76	6) 16 x 25 x 2
125	1,895	54	100	62	30	140	30 <sup>1</sup> / <sub>2</sub>	26 <sup>1</sup> / <sub>2</sub>	96	8) 16 x 25 x 2
200	2,405	60	120	78	48	174	44	40	116	12) 20 x 20 x 2
300	2,970	65	140	84	48	180	52	48	136	14) 20 x 25 x 2
400	3,680	70	160	92	48	188	52	48	156	16) 20 x 25 x 2
600	5,145	80	180	96	60	204	54	50	176	18) 20 x 25 x 2
600S	6,440	85	200	102	60	210	60	56	196	24) 20 x 25 x 2

# Dimensions

## Basic Unit

TAS-S0108

### TAS-600SS

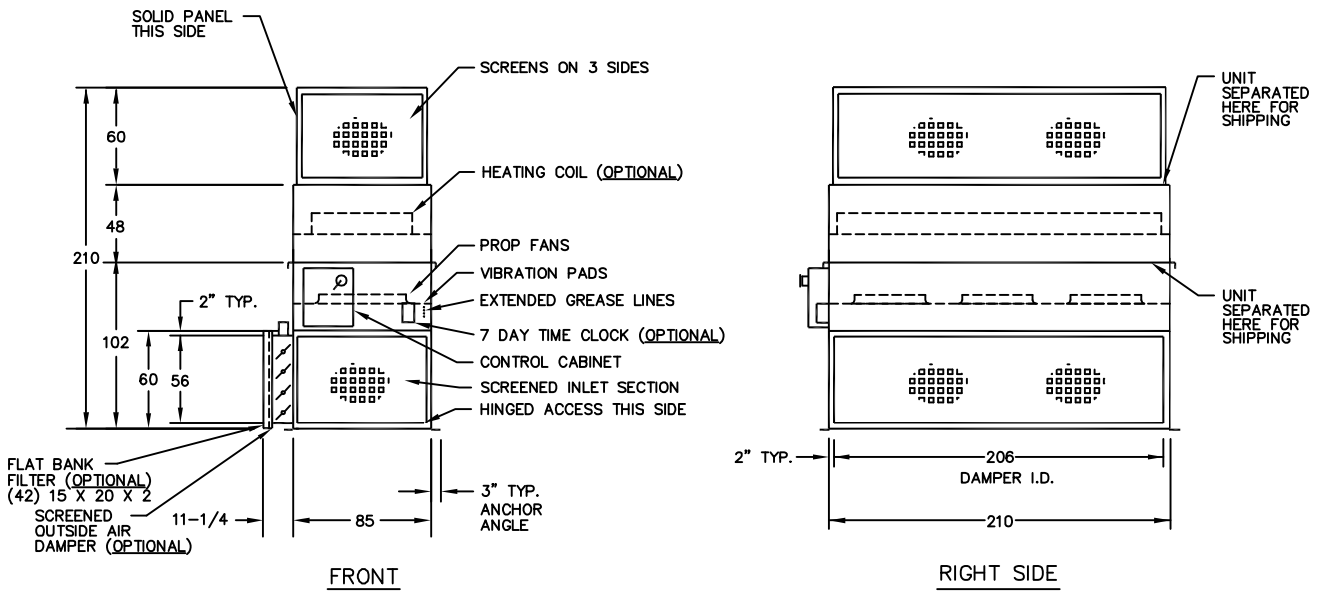

#### NOTES:

1. Discharge section is shipped knocked down (field assembly by others).
2. Approximate Shipping Weight 7, 210 lbs.

# Dimensions

## Basic Unit with Outside Air and Return Air Dampers

TAS-S0107

### TAS-75 Through TAS-600S

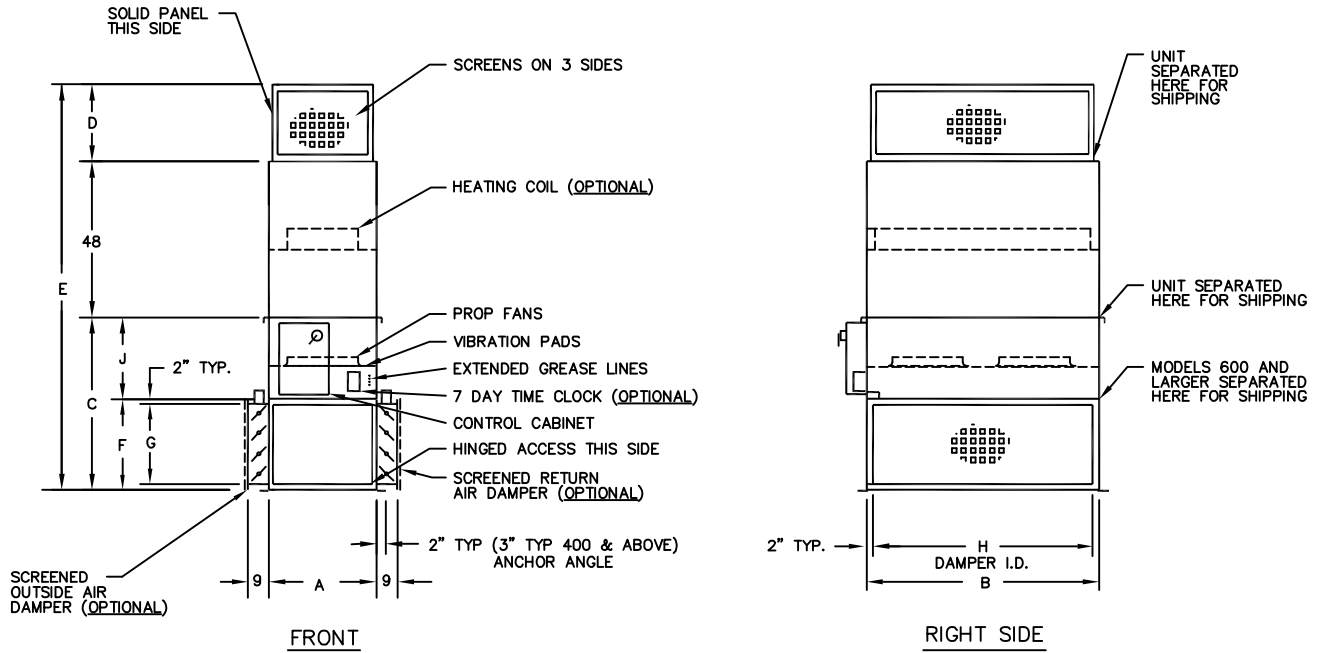

**NOTE:** On units 200 and above discharge section is shipped knocked down (field assembly by others).

Model No.	Approx. Weight	DIMENSIONS								
		A	B	C	D	E	F	G	H	J
75	1,505	36	80	72	30	152	36	32	76	36
125	2,115	54	100	85 $\frac{1}{2}$	30	163 $\frac{1}{2}$	54	50	96	31 $\frac{1}{2}$
200	2,660	60	120	94	48	192	60	56	116	34
300	3,270	65	140	97	48	195	65	61	136	32
400	4,070	70	160	112	48	208	70	66	156	42
600	5,715	80	180	122	60	230	80	76	176	42
600S	7,110	85	200	127	60	235	85	81	196	42

# Dimensions

## Basic Unit with Outside Air and Return Air Dampers

TAS-S0109

### TAS-600SS

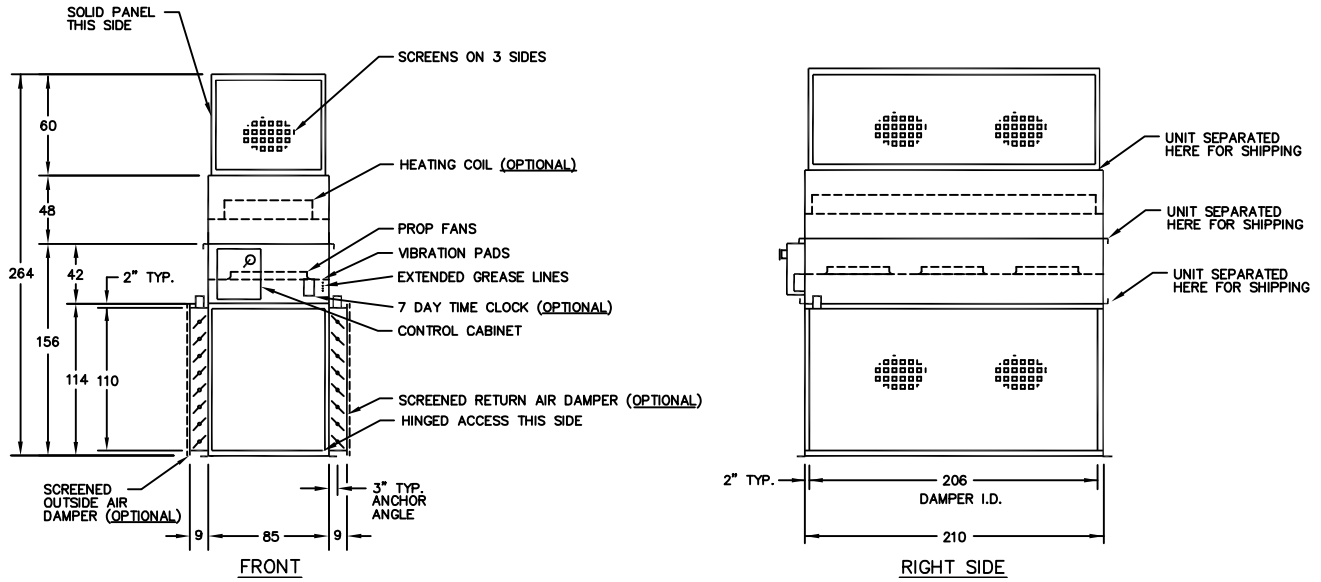

**NOTES:**

1. Discharge section is shipped knocked down (field assembly by others).
2. Approximate Shipping Weight 8, 350 lbs.

# Dimensions

## Basic Unit with Outside Air and Return Air Dampers and V-Bank Filter Section

TAS-S0111

### TAS-75 Through TAS-600S

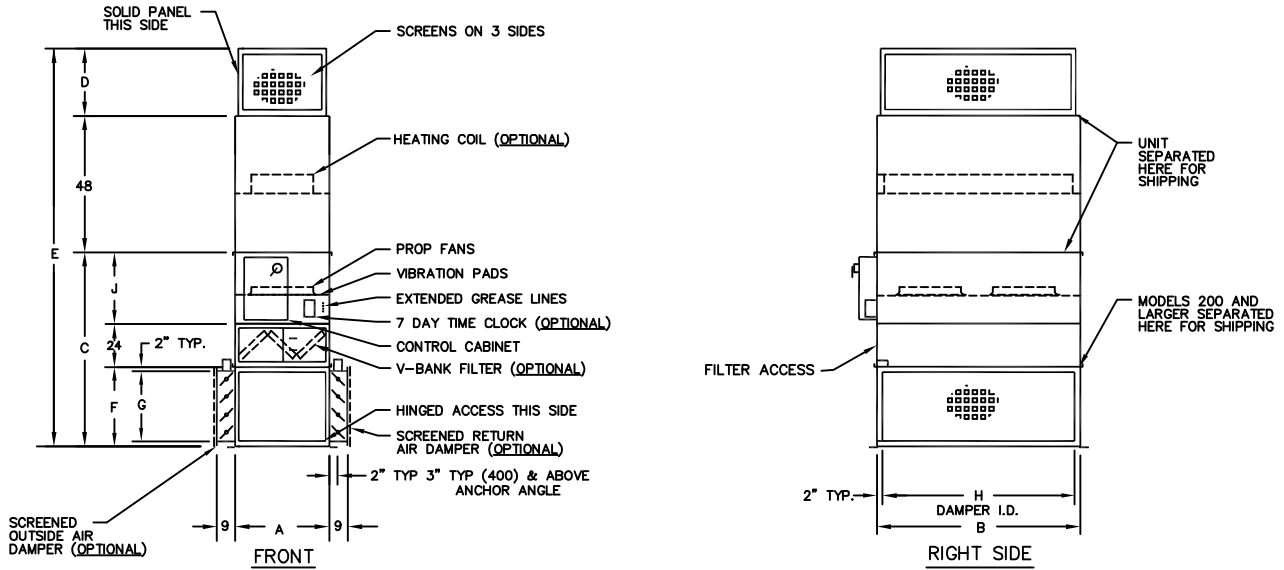

**NOTE:** On units 200 and above discharge section is shipped knocked down (field assembly by others).

Model No.	Approx. Weight	DIMENSIONS									Filters Qty) Size
		A	B	C	D	E	F	G	H	J	
75	1,705	36	80	98	30	176	36	32	76	38	12) 20 x 20 x 2
125	2,360	54	100	111 <sup>1</sup> / <sub>2</sub>	30	189 <sup>1</sup> / <sub>2</sub>	54	50	96	33 <sup>1</sup> / <sub>2</sub>	30) 20 x 20 x 2
200	2,925	60	120	120	48	216	60	56	116	36	36) 20 x 20 x 2
300	3,565	65	140	123	48	219	65	61	136	34	49) 20 x 20 x 2
400	4,390	70	160	136	48	232	70	66	156	42	64) 20 x 20 x 2
600	6,100	80	180	146	60	254	80	76	176	42	90) 20 x 25 x 2
600S	7,575	85	200	151	60	259	85	81	196	42	100) 20 x 25 x 2

# Dimensions

## Basic Unit with Outside Air and Return Air Dampers and V-Bank Filter Section

TAS-S0110

### TAS-600SS

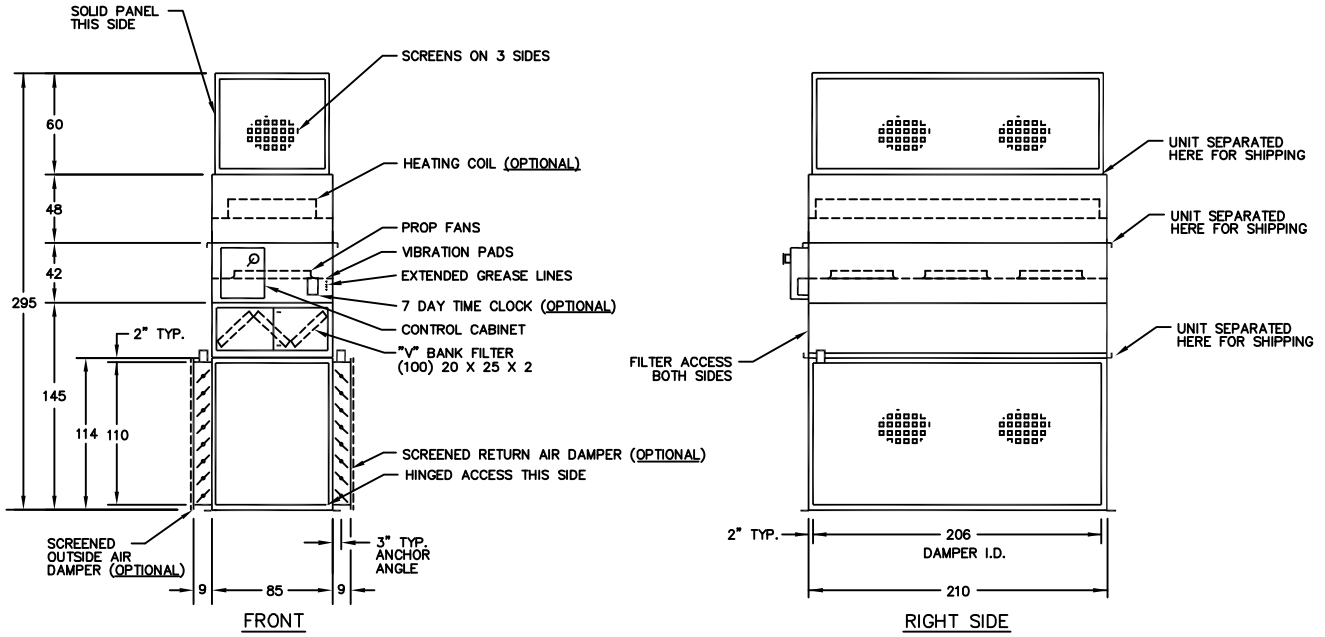

**NOTES:**

1. Discharge section is shipped knocked down (field assembly by others).
2. Approximate Shipping Weight 8,905 lbs.

# Dimensions

## Basic Unit

C000702

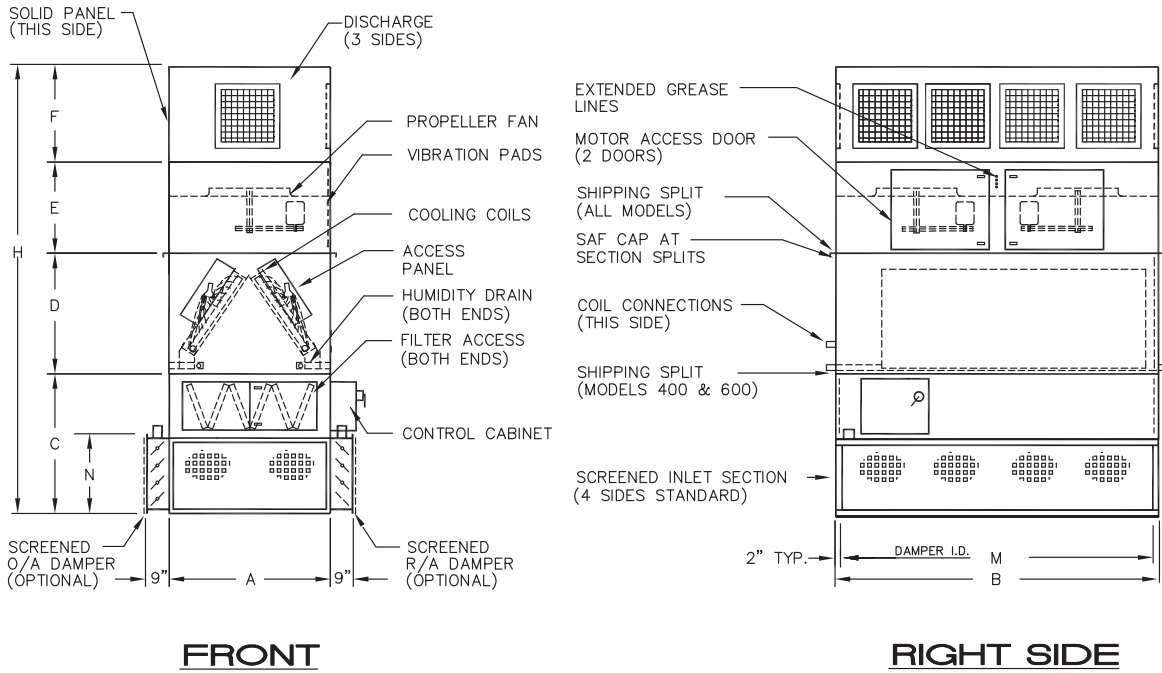

MODEL	APPROX. WEIGHT		DIMENSIONS										FILTERS QTY & SIZE	GRILLS
	WITHOUT DAMPERS	WITH TWO DAMPERS	"A"	"B"	"C"	"D"	"E"	"F"	"H"	"M"	"N"			
175	3150	3385	54	100	52	42	36	30	160	96	30	(30) 20 X 20 X 2	(6) 20 X 20	
250	4005	4395	60	120	52	48	34	48	182	116	30	(36) 20 X 20 X 2	(4) 30 X 30	
300	4675	5120	65	140	54-1/2	55	34	48	191-1/2	136	32-1/2	(49) 20 X 20 X 2	(6) 30 X 30	
400	5895	6390	70	160	59	60	40	48	207	156	37	(64) 20 X 20 X 2	(6) 34 X 34	
600	8370	9155	80	180	84	68	42	60	254	176	56	(90) 20 X 20 X 2	(6) 40 X 40	

# Dimensions

## TAA – Cooling Only

TAA-S0110

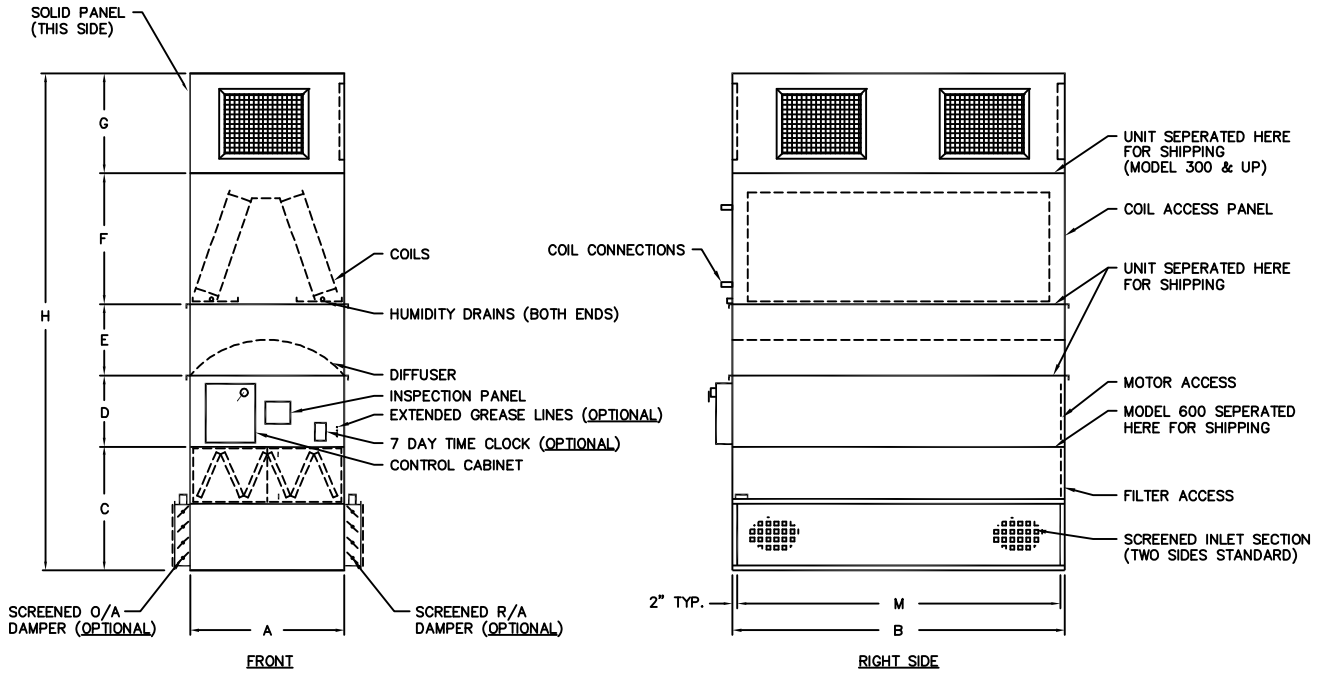

**NOTE:** Unit is suitable for indoor application.

Model No.	Approx. Weight		DIMENSIONS									Filters Qty) Size	Grilles Qty) Size
	Without Dampers	With Two Dampers	A	B	C	D	E	F	G	H	M		
175	4,350	4,585	54	100	52	30	30	42	30	184	96	30) 20 x 20 x 2	6) 20 x 20
250	5,395	5,785	60	120	52	30	30	48	48	208	116	36) 20 x 20 x 2	4) 30 x 30
300	6,765	7,210	65	140	54 <sup>1/2</sup>	32 <sup>1/2</sup>	30	55	48	220	136	49) 20 x 20 x 2	6) 30 x 30
400	8,040	8,540	70	160	59	37	30	60	48	234	156	64) 20 x 20 x 2	6) 34 x 34
600	10,855	11,640	80	180	84	56	30	68	60	298	176	90) 20 x 25 x 2	6) 40 x 40

# Dimensions

## TAA – Heating and Cooling

TAA-S0111

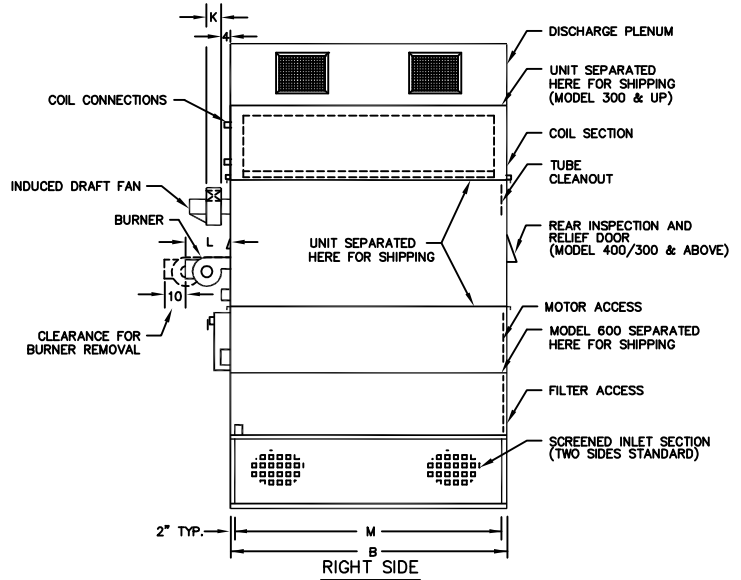
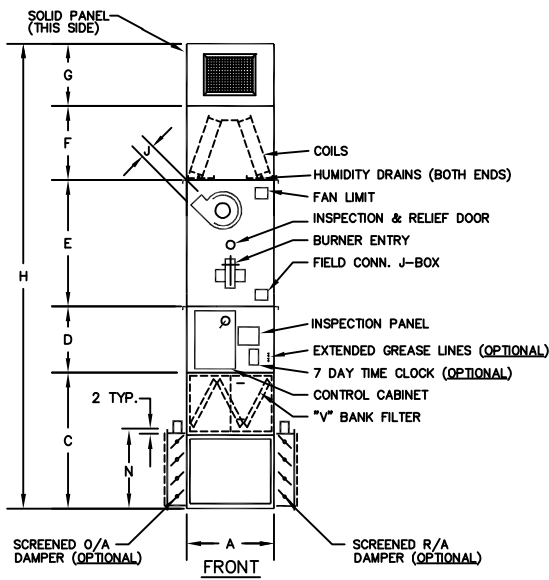

Model No.	Approx. Weight		DIMENSIONS													Filters Qty) Size	Grilles Qty) Size
	Without Dampers	With Two Dampers	A	B	C	D	E	F	G	H	J	K	L	M	N		
175/75	6,100	6,340	54	100	52	30	55	42	30	209	7	7 <sup>3</sup> / <sub>8</sub>	17	96	30	30) 20 x 20 x 2	6) 20 x 20
175/100	6,435	6,675	54	100	52	30	68	42	30	222	7	7 <sup>3</sup> / <sub>8</sub>	17	96	30	30) 20 x 20 x 2	6) 20 x 20
250/100	7,815	8,205	60	120	52	30	68	48	48	246	7	7 <sup>3</sup> / <sub>8</sub>	17	116	30	36) 20 x 20 x 2	4) 30 x 30
250/175	8,170	8,560	60	120	52	30	72	48	48	250	9	9 <sup>3</sup> / <sub>8</sub>	21	116	30	36) 20 x 20 x 2	4) 30 x 30
300/175	9,895	10,340	65	140	54 <sup>1</sup> / <sub>2</sub>	32 <sup>1</sup> / <sub>2</sub>	72	55	48	262	9	9 <sup>3</sup> / <sub>8</sub>	21	136	32 <sup>1</sup> / <sub>2</sub>	49) 20 x 20 x 2	6) 30 x 30
300/200	10,380	10,825	65	140	54 <sup>1</sup> / <sub>2</sub>	32 <sup>1</sup> / <sub>2</sub>	72	55	48	262	9	9 <sup>3</sup> / <sub>8</sub>	30	136	32 <sup>1</sup> / <sub>2</sub>	49) 20 x 20 x 2	6) 30 x 30
300/250	11,045	11,490	65	140	54 <sup>1</sup> / <sub>2</sub>	32 <sup>1</sup> / <sub>2</sub>	72	55	48	262	10 <sup>5</sup> / <sub>8</sub>	11 <sup>1</sup> / <sub>8</sub>	26	136	32 <sup>1</sup> / <sub>2</sub>	49) 20 x 20 x 2	6) 30 x 30
400/200	12,825	13,325	70	160	59	37	72	60	48	276	9	9 <sup>3</sup> / <sub>8</sub>	30	156	37	64) 20 x 20 x 2	6) 34 x 34
400/250	13,095	13,595	70	160	59	37	72	60	48	276	10 <sup>5</sup> / <sub>8</sub>	11 <sup>1</sup> / <sub>8</sub>	26	156	37	64) 20 x 20 x 2	6) 34 x 34
400/300	13,385	13,880	70	160	59	37	84	60	48	288	10 <sup>5</sup> / <sub>8</sub>	11 <sup>1</sup> / <sub>8</sub>	26	156	37	64) 20 x 20 x 2	6) 34 x 34
600/300	16,525	17,310	80	180	84	56	84	68	60	352	10 <sup>5</sup> / <sub>8</sub>	11 <sup>1</sup> / <sub>8</sub>	26	176	56	90) 20 x 25 x 2	6) 40 x 40
600/400	16,950	17,735	80	180	84	56	100	68	60	368	10 <sup>5</sup> / <sub>8</sub>	11 <sup>1</sup> / <sub>8</sub>	32	176	56	90) 20 x 25 x 2	6) 40 x 40

# Dimensions

## TAJ – Heating Only

TAJ-S0101

### TAJ-Single

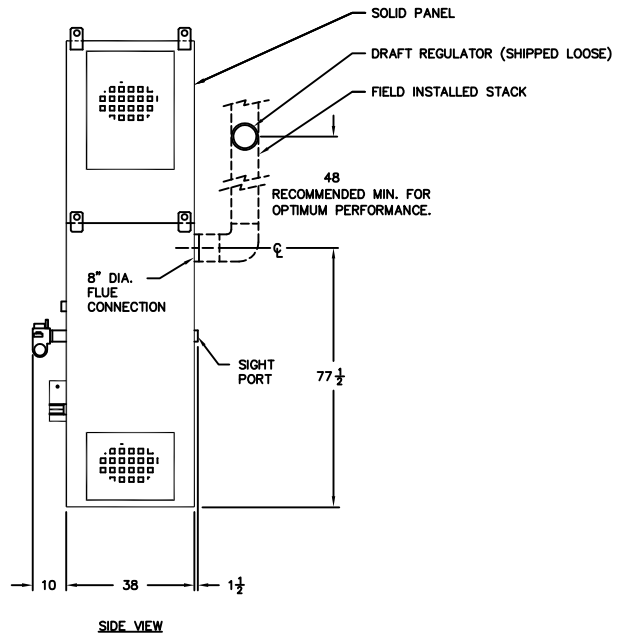
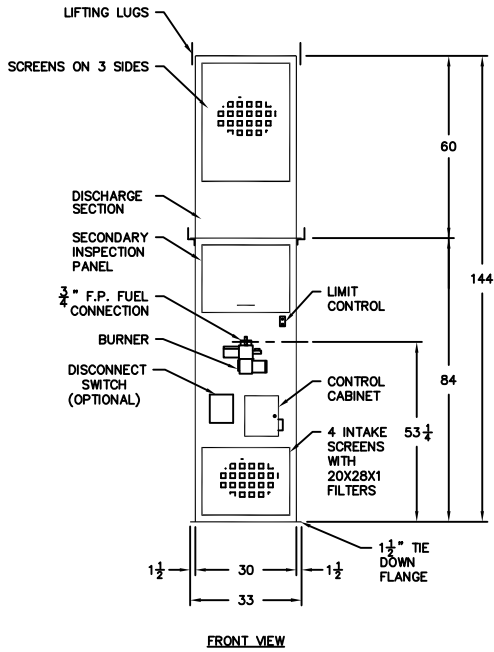

**NOTES:**

1. Unit suitable for indoor application
2. Unit to have discharge section shipped separate for field mounting by others.
3. Approximate shipping weight 800 pounds.
4. Draft control must be located in the same room as the heater.
5. Do not aim air discharge grilles in the direction of the draft control.
6. TAJ not approved for installations in Canada.

## TAJ – Heating Only

TAJ-S0100

### TAJ-Double

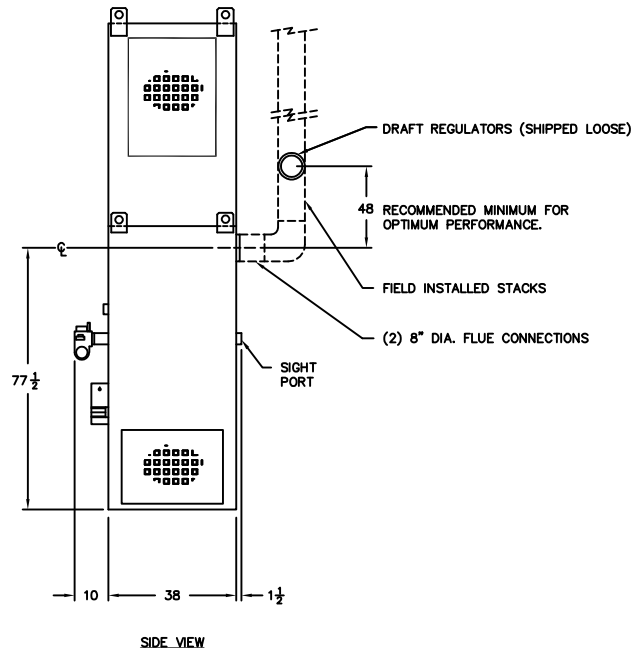
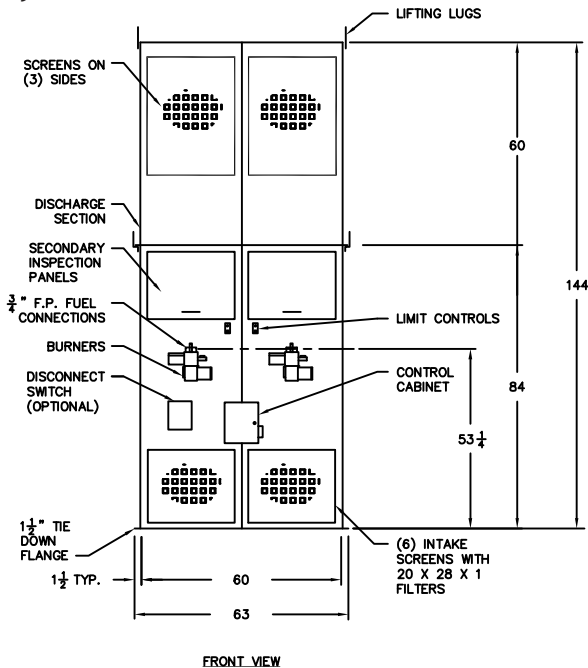

**NOTES:**

1. Unit suitable for indoor application
2. Unit to have discharge section shipped separate for field mounting by others.
3. Approximate shipping weight 1,600 pounds.
4. Draft control must be located in the same room as the heater.
5. Do not aim air discharge grilles in the direction of the draft control.
6. TAJ not approved for installations in Canada.

# Dimensions

## TAJ – Heating and Cooling

TAJ-S0102

### TAJ-Single

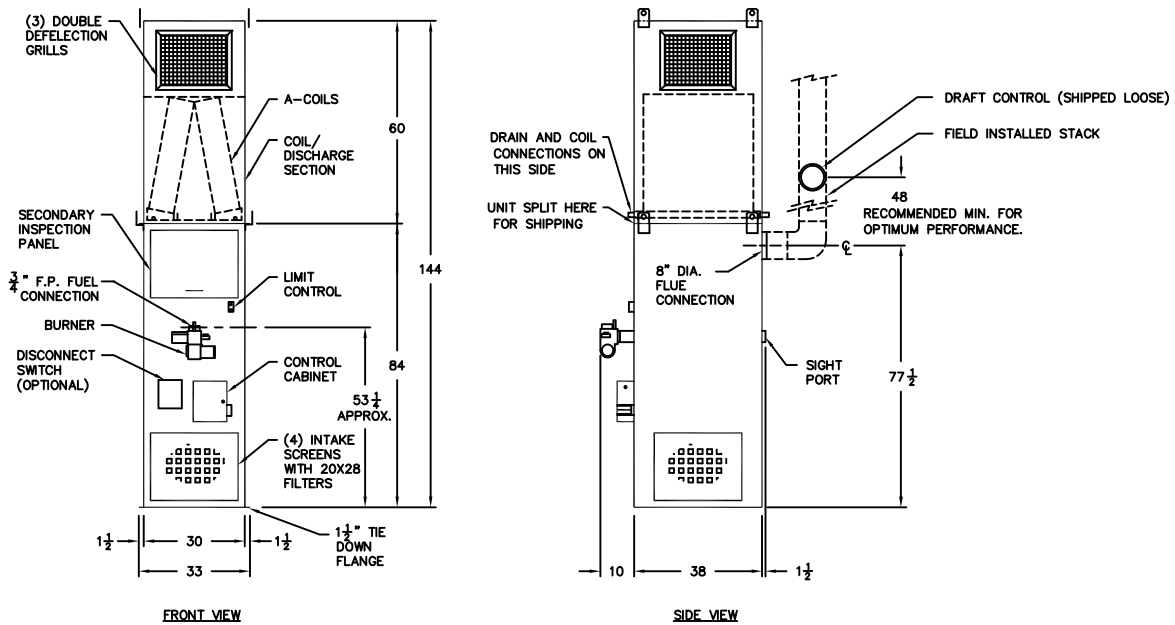

**NOTES:**

1. Unit suitable for indoor application
2. Approximate shipping weight 1,150 pounds.
3. Draft control must be located in the same room as the heater.
4. Do not aim air discharge grilles in the direction of the draft control.
5. TAJ not approved for installations in Canada.

## TAJ – Heating and Cooling

TAJ-S0105

### TAJ-Double

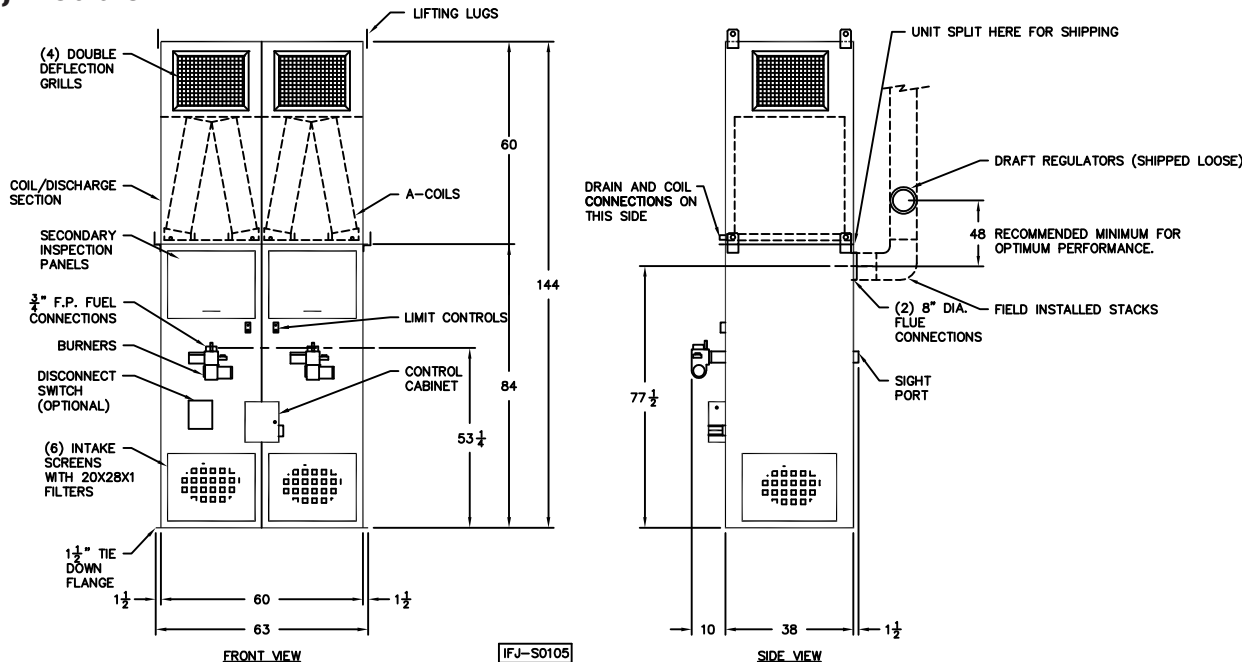

**NOTES:**

1. Unit suitable for indoor application
2. Unit to have discharge section shipped separate for field mounting by others.
3. Approximate shipping weight 2,300 pounds.
4. Draft control must be located in the same room as the heater.
5. Do not aim air discharge grilles in the direction of the draft control.
6. TAJ not approved for installations in Canada.

# Gas Piping Layout

## Schematic Component Diagrams

C000513A

### TAP and TAA with Optional Gas Heat Only

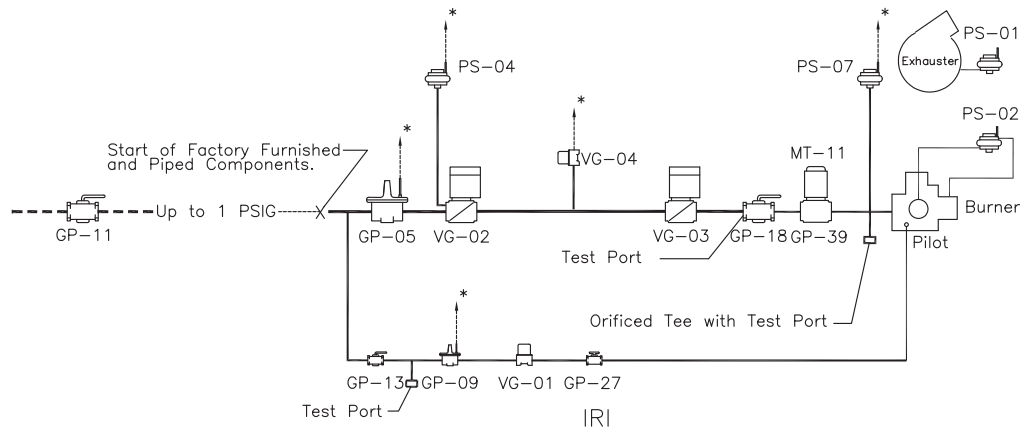
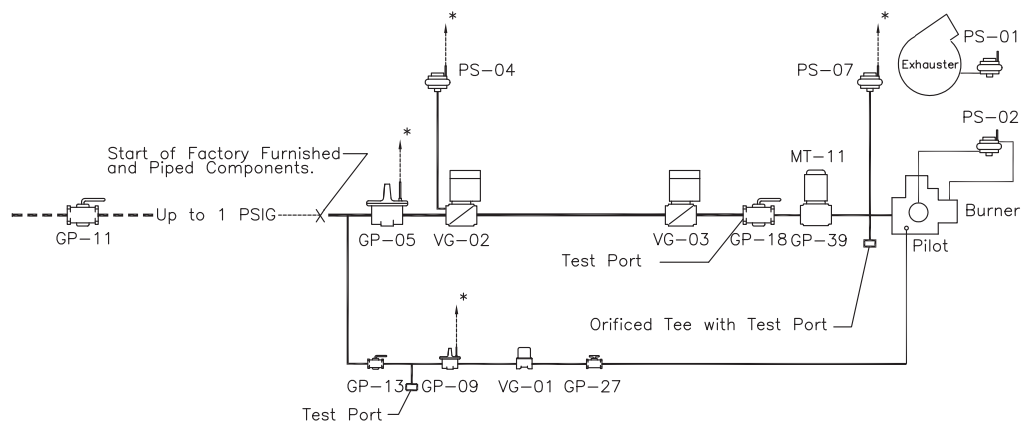
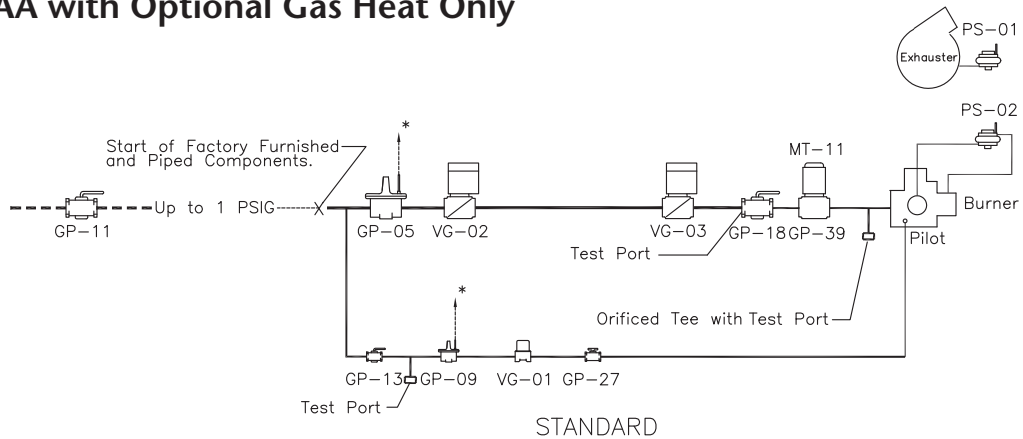

#### COMPONENT IDENTIFICATION

GP-05 MAIN GAS PRESSURE REGULATOR  
 GP-09 PILOT GAS PRESSURE REGULATOR  
 GP-11 MAIN GAS SHUT-OFF VALVE  
 (SHIPPED LOOSE)  
 GP-13 PILOT GAS SHUT-OFF VALVE  
 GP-18 AUXILIARY GAS SHUT-OFF VALVE  
 GP-27 ORIFICED NEEDLE VALVE  
 GP-39 BUTTERFLY VALVE  
 (MODULATING BURNERS ONLY)  
 MT-11 BUTTERFLY VALVE OPERATOR  
 (MODULATING BURNERS ONLY)

PS-01 DRAFT PROVING SWITCH  
 PS-02 BURNER AIR FLOW SWITCH  
 PS-04 LOW GAS PRESSURE SWITCH  
 PS-07 HIGH GAS PRESSURE SWITCH  
 VG-01 PILOT GAS VALVE  
 VG-02 MAIN GAS VALVE  
 VG-03 AUXILIARY GAS VALVE  
 VG-04 N/O VENT VALVE

#### NOTES:

1. Vent limiting devices provided wherever possible, when venting is required \* the venting to outside is by others on indoor units and furnished by factory on outdoor units.
2. Models through 750 MBH output require 6" W.C. minimum inlet pressure. Larger models require 8" W.C. minimum inlet pressure. Contact factory for inlet pressures below these minimums.
3. Standard manifold meets FM requirements for units less than or equal to 2000 MBH output for ETL listed units.
4. Standard manifold meets IRI requirements for ETL listed units.

# Equipment Sizing



## Selection Procedure

Sizing Air Turnover systems depends upon several factors:

- Building height
- Building heating or cooling load
- Number and useage of openings to out-doors
- Acceptable floor to ceiling temperature spread
- Net building volume
- Fill factor

## Equipment Selection

This process is best illustrated by an example.

### Problem

Heat a 220' x 250' x 26' dry storage warehouse building. 10% of the space is occupied by inventory. Fuel will be natural gas. Heat loss has been calculated at 1,250,000 Btu/hr.

### Solution

#### Step 1

$$SCFM = \frac{\text{Total Btu/hr}}{30^{\circ}\text{F Temp Rise} \times 1.085}$$

SCFM with 30°F TR = 38,402

### NOTE

Temperature rise should not exceed 30°F for a straight heating application. If the unit will also provide make-up air, this may be increased to 45°F when 25% or more outside air is used.

Temperature drop should not exceed 15°F for cooling applications

#### Step 2

If temperature spread from floor to ceiling is not a concern, select one model TAP-250/175 with 1,250,000 Btu/hr output, delivering 39,000 SCFM.

If floor to ceiling temperature spread is a concern, go to next step.

#### Step 3

Total building area is 55,000 square feet.

#### Step 4

55,000 square feet x 26' (ceiling height) x 0.90 (% of building not filled).

#### Step 5

Net building vouldme is 1,287,000 cubic feet.

#### Step 6

Reference Air Turnover Charts below. Generally; the higher the Air Turnover/hr, the lower the floor to ceiling spread.

#### Step 7

$$SCFM = \frac{\text{Net building volume} \times \text{AT/H}}{60}$$

SCFM with 2.25 AT/H = 48,263

Select one model TAP-300/175 with 1,250,000 Btu/hr output, delivering 49,000 SCFM.

**Heating Air Turnover Chart**  
(Number of Air Turns/hr.)

Type of Building	Inside-Outside Design Temperature			
	20°F ΔT	40°F ΔT	60°F ΔT	80°F ΔT
Relavately new building, little air infiltration, "tight"; Roof R-15 Walls R-10	1.25-1.75	1.5-2	1.75-2.25	2-2.5
Middle-age building, some glass, moderate air infiltration; Roof R-8 Walls R-6	1.5-2	1.75-2.25	2.25-2.75	2.5-3
Older Building or Single pane glass, discernible air infiltration ; Roof R-4 Walls R-2	1.75-2.25	2-2.5	2.75-3.25	3-3.5

**Cooling Air Turnover Chart**  
(Number of Air Turns/hr.)

Type of Building	Inside-Outside Design Temperature		
	15°F ΔT	20°F ΔT	25°F ΔT
Relavately new building, little air infiltration, "tight"; Roof R-15 Walls R-10	3.5-3.75	3.75-4	4.25-4.5
Middle-age building, some glass, moderate air infiltration; Roof R-8 Walls R-6	3.75-4	4.25-4.5	4.5-4.75
Older Building or Single pane glass, discernible air infiltration ; Roof R-4 Walls R-2	4-4.25	4.5-4.75	4.75-5

# • TAP Guide Specifications



Base Bid Temprite Model TAP \_\_\_\_\_ indirect fired heating Air Turnover Unit(s) designed to draw return air at floor level and discharge heated air near the ceiling. The unit shall be factory fabricated, assembled, wired and tested prior to shipment in accordance with the specification and equipment schedule. The unit will include all components herein and as shown on the drawings. Alternate equipment, equal in design, construction, performance and capacity to unit(s) specified, must be shown with price deduct/add, if any. Approval of alternate equipment will be subject to review of shop drawings. The unit shall be capable of delivering \_\_\_\_\_ SCFM using \_\_\_\_\_ horsepower (ODP) (TEFC) motors operating on (208)(230)(460)/3/60. The unit shall be ETL listed.

## CASING

The unit casing shall consist of 18 gauge galvanized steel panels over a structural steel framework to ensure rigidity. Cabinet construction shall allow unit(s) to be mounted in the vertical arrangement with no external framework. The casing enclosing the heat exchanger shall be of double wall construction with a galvanized steel inner wall serving as a radiation shield. Radiation and transmission losses shall not exceed 2% of the rated output.

## PROPELLER SECTION

Each unit shall be supplied with multiple belt driven turbine four-bladed energy efficient propeller fans rated in accordance with AMCA standards. Each propeller fan will be driven by a three phase motor mounted on an adjustable base. The propellers are to be mounted on heavy duty, turned and ground and polished solid steel shafts designed for a maximum operating speed not to exceed 75% of its first critical speed.

The bearings are to be of the heavy-duty industrial pre-lubricated, self aligning type equipped with extended lube lines to control side of unit.

Drives shall have a capacity 25% greater than the motor horsepower. The motor sheave shall be of the adjustable pitch type for motors up to  $7\frac{1}{2}$  H.P.

Each propeller fan motor shall be mounted on an adjustable base and wired in flexible conduit to the control panel in the factory.

Unit shall have low velocity return air section at floor level with screens on four sides.

Hinged access door, with cadmium plated piano type hinges, into return air section shall be supplied to allow physical entry for required inspections and periodic maintenance. Access door shall be complete with door latches, fasteners, and keyed lock to prevent unauthorized entry. An access door interlock switch, which will break power to propeller fans upon entry, will be provided as safety control.

## INDIRECT GAS FIRED SECTION

The entire primary heat transfer surface and header shall be of 400 series stainless steel; the secondary heat transfer surface shall be (mild steel) (400 series stainless steel). The heat exchanger design shall permit unrestricted lateral and peripheral expansion during the heating and cooling cycle. The flue gas travel shall be of four-pass design, with no internal baffles. The surface temperature of the heat exchanger shall not exceed 75% of its scaling temperature when operating at rated capacity. The heat exchanger shall be rated at a minimum of 80% efficiency at rated output. A pressure relief door complete with an observation window to view the complete flame and pilot shall be provided.

## DIRECT DRIVE INDUCED DRAFT FAN

An integrally mounted, heavy duty, non-clogging radial blade induced draft fan complete with direct drive motor shall be provided. The induced draft fan shall be adequately sized to insure proper draft conditions when operating at rated capacity and equipped with a manual damper complete with locking quadrant to ensure proper draft and extended heat exchanger performance.

## BURNER

The gas burner shall be of the power type, complete with integral combustion air blower and motor, combustion air proving switch, and removable pilot assembly. The combustion air damper shall be interlocked with the gas control valve to insure a proper gas/air mixture throughout the complete range of operation. Burner and controls shall be capable of delivering \_\_\_\_\_ MBH output firing on (natural gas) (propane) at an inlet pressure of \_\_\_\_\_ (inches water column) (PSIG) and in accordance with (manufacturer's standard) (FM) (IRI) requirements. Burner and controls shall be arranged for (On-Off) (High/Low/Off) (Full Modulation with low fire start) with factory mounted return air thermostat. The factory mounted, wired and piped valve train shall be complete with:

- low pressure appliance regulator
- motorized gas control valve
- main manual test firing shut-off valve
- pilot manual shut-off valve
- pilot pressure regulator
- pilot automatic shut-off valve
- pilot manual test firing shut-off valve

# : TAP Guide Specifications



## DISCHARGE PLENUM

Unit shall have low velocity discharge air plenum with screens on three sides.

## ELECTRICAL CONTROLS

A NEMA 1 control panel complete with hinged access door shall be mounted on unit. All control components are to be labeled and individually wired to a numbered terminal strip to aid in servicing. All wiring shall be color coded and number tagged at each end to match the control diagram supplied. Full operating and maintenance instructions shall accompany each unit. All wiring between the controls and valves shall be run in flexible conduit. All electrical components shall bear the U.L. label. The control system shall include but not be limited to the following components required for automatic operation:

- control circuit transformer
- fan motor starters, overloads and sub-circuit fuses
- control circuit fuses
- control relays
- circuit analyzer troubleshooting lights
- electronic flame relay complete with alarm contacts
- induced draft fan air proving differential switch
- high limit switch
- automatic/manual fan switch
- heavy duty ignition transformer

## OPTIONAL EQUIPMENT & CONTROLS

1. Alternate arrangement with one factory mounted damper for 0 - 25% of winter outside air with (two position) (modulating) motor(s).
2. Alternate arrangement with two factory mounted mixing dampers for 0 - 100% control of winter outside air with (two position) (modulating) motor(s).
3. Four sided flat bank permanent filters for filtering 100% return air.
4. V-Bank filter section with nominal 2" thick cleanable filters.
5. Discharge plenum with screens on four sides.
6. Discharge plenum extension.
7. Six bladed propeller fans
8. High Efficiency propeller fan motors.
9. Clogged filter switch and indicating light.
10. Disconnect switch
11. Painted galvanized casing
12. High gas pressure regulator (shipped loose for inlet pressures over 1 PSIG).
13. Remote control panel.
14. Night set back thermostat
15. Electronic time clock
16. Timed freeze protection
17. Smoke detector
18. Mixed air temperature controller for mixing dampers.
19. Manual potentiometer controller for mixing dampers.
20. Pressure control system for mixing dampers.
21. TracRite DDC Control System.

# : TAS Guide Specifications



Base Bid Temprite Model TAS \_\_\_\_\_  
Air Turnover Unit(s) designed to draw return air at floor level and discharge air near the ceiling. The unit shall be factory fabricated, assembled, wired and tested prior to shipment in accordance with the specification and equipment schedule. The unit will include all components herein and as shown on the drawings. Alternate equipment, equal in design, construction, performance and capacity to unit(s) specified, must be shown with price deduct/add, if any. Approval of alternate equipment will be subject to review of shop drawings. The unit shall be capable of delivering \_\_\_\_\_ SCFM using \_\_\_\_\_ horsepower (ODP) (TEFC) motors operating on (208)(230)(460)/3/60. The unit shall be ETL listed.

## CASING

The unit casing shall consist of 18 gauge galvanized steel panels over a structural steel framework to ensure rigidity. Cabinet construction shall allow unit(s) to be mounted in the vertical arrangement with no external framework.

## PROPELLER SECTION

Each unit shall be supplied with multiple belt driven turbine four-bladed energy efficient propeller fans rated in accordance with AMCA standards. Each propeller fan will be driven by a three phase motor mounted on an adjustable base. The propellers are to be mounted on heavy duty, turned and ground and polished solid steel shafts designed for a maximum operating speed not to exceed 75% of its first critical speed.

The bearings are to be of the heavy-duty industrial pre-lubricated, self aligning type equipped with extended lube lines to control side of unit.

Drives shall have a capacity 25% greater than the motor horsepower. The motor sheave shall be of the adjustable pitch type for motors up to  $7\frac{1}{2}$  H.P.

Each propeller fan motor shall be mounted on an adjustable base and wired in flexible conduit to the control panel in the factory.

Unit shall have low velocity return air section at floor level with screens on four sides.

Hinged access door, with cadmium plated piano type hinges, into return air section shall be supplied to allow physical entry for required inspections and periodic maintenance. Access door shall be complete with door latches, fasteners, and keyed lock to prevent unauthorized entry. An access door interlock switch, which will break power to propeller fans upon entry, will be provided as safety control.

## DISCHARGE PLENUM

Unit shall have low velocity discharge air plenum with screens on three sides.

## ELECTRICAL CONTROLS

A NEMA 1 control panel complete with hinged access door shall be mounted on unit. All control components are to be labeled and individually wired to a numbered terminal strip to aid in servicing. All wiring shall be color coded and number tagged at each end to match the control diagram supplied. Full operating and maintenance instructions shall accompany each unit. All wiring between the controls shall be run in flexible conduit. All electrical components shall bear the U.L. label. The control system shall include but not be limited to the following components required for automatic operation:

- control circuit transformer
- fan motor starters, overloads and sub-circuit fuses
- control circuit fuses
- control relays
- circuit analyzer troubleshooting lights

## OPTIONAL EQUIPMENT & CONTROLS

1. Alternate arrangement with one factory mounted damper for 0 - 25% of winter outside air with (two position) (modulating) motor(s).
2. Alternate arrangement with two factory mounted mixing dampers for 0 - 100% control of winter outside air with (two position) (modulating) motor(s).
3. Four sided flat bank permanent filters for filtering 100% return air.
4. V-Bank filter section with nominal 2" thick cleanable filters.
5. Discharge plenum with screens on four sides.
6. Discharge plenum extension.
7. Six bladed propeller fans
8. High Efficiency propeller fan motors.
9. Clogged filter switch and indicating light.
10. Disconnect switch
11. Painted galvanized casing
12. Remote control panel.
13. Night set back thermostat
14. Electronic time clock
15. Smoke detector
16. Mixed air temperature controller for mixing dampers.
17. Manual potentiometer controller for mixing dampers.
18. Pressure control system for mixing dampers.
19. TracRite DDC Control System.

# : TAC Guide Specifications



Base Bid Temprite Model TAC \_\_\_\_\_ Air Turnover Cooling Unit(s) designed to draw return air at floor level and discharge conditioned air near the ceiling. The unit shall be factory fabricated, assembled, wired and tested prior to shipment in accordance with the specification and equipment schedule. The unit will include all components herein and as shown on the drawings. Alternate equipment, equal in design, construction, performance and capacity to unit(s) specified, must be shown with price deduct/add, if any. Approval of alternate equipment will be subject to review of shop drawings. The unit shall be capable of delivering \_\_\_\_\_ SCFM with \_\_\_\_\_ tons cooling with (DX)(CW) coils using two (2) \_\_\_\_\_ HP (ODP)(TEFC) motors operating on (208)(230)(460)/3/60. The unit shall be ETL listed.

## CASING

The unit casing shall consist of 18 gauge galvanized steel panels over a structural steel framework to ensure rigidity. Cabinet construction shall allow unit(s) to be mounted in the vertical arrangement with no external framework.

Hinged access doors with cadmium plated piano type hinges shall be supplied to allow physical entry to all sections requiring inspections and periodic maintenance. Access doors shall be complete with 1" thick insulation, interior metal liner, captive screws, fasteners, and handles.

Unit shall be complete with V-Bank filter section with nominal 2" thick (throwaway) (pleated) (cleanable) filters to protect the cooling coils.

All sections downstream of the cooling coils will be insulated with 1", 1-1/2# fiberglass insulation pin-spotted to unit casing.

Unit shall have low velocity return air section at floor level with screens on four sides.

## PROPELLER SECTION

Each unit shall be supplied with multiple belt driven turbine bladed energy efficient propeller fans rated in accordance with AMCA standards. Each propeller fan will be driven by a three phase motor mounted on an adjustable base. The propellers are to be mounted on heavy duty, turned, ground and polished solid steel shafts designed for a maximum operating speed not to exceed 75% of its first critical speed.

The bearings are to be of the heavy-duty industrial pre-lubricated, self aligning type equipped with extended lube lines to control side of unit.

Drives shall have a capacity 25% greater than the motor horsepower. The motor sheave shall be of the adjustable pitch type for motors up to 7-1/2 HP.

Each propeller fan motor shall be mounted on an adjustable base and wired in flexible conduit to the control panel in the factory.

## COOLING COIL SECTION

Two four row (DX) (CW) cooling coils with 5/8" seamless copper tubes, aluminum fins and galvanized steel casing. Headers are to be made of non-ferrous material with vents, drains and suitable for 200 psi working pressure. Coils shall be mounted in an "A" arrangement with insulated stainless steel drain pan under each coil. Coil velocity shall not exceed 550 FPM. Section will be furnished with 1", 1-1/2# fiberglass insulation pin-spotted to unit casing.

## DISCHARGE PLENUM

A discharge plenum with aluminum high velocity discharge grilles on three sides will be provided. The plenum will be furnished with 1", 1-1/2# fiberglass insulation pin-spotted to unit casing. Discharge grilles shall be sized at the factory to provide discharge velocity required for proper air circulation in conditioned space.

# : TAC Guide Specifications



## ELECTRICAL CONTROLS

A NEMA 1 control panel complete with hinged access door shall be mounted on unit. All control components are to be labeled and individually wired to a numbered terminal strip to aid in servicing. All wiring shall be color coded and number tagged at each end to match the control diagram supplied. Full operating and maintenance instructions shall accompany each unit. All wiring between controls shall be run in flexible conduit. All electrical components shall bear the U. L. label. The control system shall include but not be limited to the following components required for automatic operation:

- control circuit transformer
- fan motor starters, overloads and sub-circuit fuses
- control circuit fuses
- control relays

## OPTIONAL EQUIPMENT & CONTROLS

1. One factory mounted damper for 0 – 25% of outside air with (two position) (modulating) motor(s).
2. Two factory mounted mixing dampers for 0 – 100% control of outside air with (two position) (modulating) motor(s).
3. Mixed air temperature controller for mixing dampers.
4. Manual potentiometer controller for mixing dampers.
5. Pressure control system for mixing dampers.
6. Insulated Discharge Plenum Extension with 1", 1-1/2# fiberglass insulation pin-spotted to unit casing.
7. Discharge Plenum with aluminum high velocity discharge grilles on 4 sides.
8. High Efficiency fan motors.
9. Clogged filter switch and indicating light.
10. Non-Fused disconnect switch.
11. Painted galvanized casing.
12. Circuit analyzer trouble shooting lights.
13. Electronic time clock.
14. Remote control panel.
15. On-Off night setback thermostat.
16. Smoke detector.
17. TracRite DDC Control System.

# • TAA Guide Specifications



Base Bid Temprite Model TAA \_\_\_\_\_  
Air Turnover (Heating and Cooling) (Cooling) Unit(s) designed to draw return air at floor level and discharge conditioned air near the ceiling. The unit shall be factory fabricated, assembled, wired and tested prior to shipment in accordance with the specification and equipment schedule. The unit will include all components herein and as shown on the drawings. Alternate equipment, equal in design, construction, performance and capacity to unit(s) specified, must be shown with price deduct/add, if any. Approval of alternate equipment will be subject to review of shop drawings. The unit shall be capable of delivering \_\_\_\_\_ SCFM with \_\_\_\_\_ tons cooling with (DX) (CW) coils using a \_\_\_\_\_ horsepower (ODP) (TEFC) motor operating on (208) (230) (460) /3/60. The unit shall be ETL listed.

## CASING

The unit casing shall consist of 18 gauge galvanized steel panels over a structural steel framework to ensure rigidity. Cabinet construction shall allow unit(s) to be mounted in the vertical arrangement with no external framework.

Hinged access doors with cadmium plated piano type hinges shall be supplied to allow physical entry to all sections requiring inspections and periodic maintenance. Access doors shall be complete with 1" thick insulation, interior metal liner, captive screws, fasteners, and handles.

Unit shall be complete with V-Bank filter section with nominal 2" thick (throwaway) (pleated) (cleanable) filters to protect the cooling coils.

The inlet section shall have screened return air openings on the two long sides of unit at floor level.

## BLOWER SECTION

Each unit shall be supplied with three centrifugal forward curve, DWDI blowers rated in accordance with AMCA standards. The blowers are to be mounted on a heavy duty, turned and ground and polished solid steel shaft designed for a maximum operating speed not to exceed 75% of its first critical speed.

The bearings are to be of the heavy-duty industrial pre-lubricated, self aligning type. All models will have a double row spherical roller bearing on drive side.

Drives shall have a capacity 25% greater than the motor horsepower. Blower and motor sheaves shall be laser aligned to provide maximum belt and sheave life. The motor sheave shall be of the adjustable pitch type for motors up to 7 1/2 H.P.

The fan motor shall be mounted on an adjustable base and wired in flexible conduit to the control panel in the factory. All units will be laser aligned in the factory to provide minimum vibration and maximum bearing life. The shaft and bearings shall be laser aligned at the factory to ensure straightness. The fan wheel, shaft, drives, and motor assembly shall be vibration balanced as a complete assembly in the factory.

## INDIRECT GAS FIRED SECTION (Optional)

The entire primary heat transfer surface and header shall be of 400 series stainless steel; the secondary heat transfer surface shall be (mild steel) (400 series stainless steel). The heat exchanger design shall permit unrestricted lateral and peripheral expansion during the heating and cooling cycle. The flue gas travel shall be of four-pass design, with no internal baffles. The surface temperature of the heat exchanger shall not exceed 75% of its scaling temperature when operating at rated capacity. The heat exchanger shall be rated at a minimum of 80% efficiency at rated output. A pressure relief door complete with an observation window to view the complete flame and pilot shall be provided.

The casing enclosing the optional heat exchanger shall be of double wall construction with a galvanized steel inner wall serving as a radiation shield. Radiation and transmission losses shall not exceed 2% of the rated output. This section shall be insulated with 1", 1 1/2 lb. density insulation.

## DIRECT DRIVE INDUCED DRAFT FAN (Optional)

An integrally mounted, heavy duty, non-clogging radial blade induced draft fan complete with direct drive motor shall be provided. The induced draft fan shall be adequately sized to insure proper draft conditions when operating at rated capacity and equipped with a manual damper complete with locking quadrant to ensure proper draft and extended heat exchanger performance.

## BURNER (Optional)

The gas burner shall be of the power type, complete with integral combustion air blower and motor, combustion air proving switch, and removable pilot assembly. The combustion air damper shall be interlocked with the gas control valve to insure a proper gas/air mixture throughout the complete range of operation. Burner and controls shall be capable of delivering \_\_\_\_\_ MBH output firing on (natural gas) (propane) at an inlet pressure of \_\_\_\_\_ (inches water column) (PSIG) and in accordance with (manufacturer's standard) (FM) (IRI) requirements. Burner and controls shall be arranged for (On-Off) (High/Low/Off) (Full Modulation with low fire start).

The factory wired and piped valve train shall be complete with:

- low pressure appliance regulator
- motorized gas control valve
- main manual test firing shut-off valve
- pilot manual shut-off valve
- pilot pressure regulator
- pilot automatic shut-off valve
- pilot manual test firing shut-off valve

# : TAA Guide Specifications



## COOLING COIL SECTION

Two four row (DX) (CW) cooling coils with copper tubes, aluminum fins and galvanized steel casing. Headers to be non-ferrous with vents, drains and suitable for 200 psi working pressure. Coils shall be mounted in an "A" coil arrangement with insulated stainless steel drain pan under each coil. Coil velocity shall not exceed 550 FPM. Section will be furnished with 1", 1 1/2" # fiberglass insulation pin-spotted to casing.

Units without optional heat section will be provided with a diffuser section between blower section and coil section.

## DISCHARGE PLENUM

A discharge plenum with aluminum high velocity discharge grilles on three sides will be provided. The plenum will be furnished with 1", 1 1/2" # fiberglass insulation pin-spotted to casing. Discharge grilles shall be sized at the factory to provide discharge velocity required for proper air circulation in conditioned space.

## ELECTRICAL CONTROLS

A NEMA 1 control panel complete with hinged access door shall be mounted on unit. All control components are to be labeled and individually wired to a numbered terminal strip to aid in servicing. All wiring shall be color coded and number tagged at each end to match the control diagram supplied. Full operating and maintenance instructions shall accompany each unit. All wiring between controls shall be run in flexible conduit. All electrical components shall bear the U.L. label. The control system shall include but not be limited to the following components required for automatic operation:

- control circuit transformer
- fan motor starters, overloads and sub-circuit fuses
- control circuit fuses
- control relays

With optional gas heat section

- electronic flame relay complete with alarm contacts
- induced draft fan air proving differential switch
- high limit switch
- automatic/manual fan switch
- heavy duty ignition transformer

## OPTIONAL EQUIPMENT & CONTROLS

1. One factory mounted damper for 0 - 25% of winter outside air with (two position) (modulating) motor(s).
2. Two factory mounted mixing dampers for 0 - 100% control of winter outside air with (two position) (modulating) motor(s).
3. Insulated Discharge Plenum Extension with 1", 1 1/2" # fiberglass insulation pin-spotted to casing.
4. Insulated blower section with 1", 1 1/2" # fiberglass insulation pin-spotted to casing.
5. Insulated inlet section with 1", 1 1/2" # fiberglass insulation pin-spotted to casing.
6. Insulated diffuser section with 1", 1 1/2" # fiberglass insulation pin-spotted to casing.
7. Discharge plenum with aluminum high velocity discharge grilles on 4 sides
8. Extended lube lines
9. Internal blower/motor isolation
10. High Efficiency blower motor
11. Clogged filter switch and indicating light.
12. Disconnect switch
13. Painted galvanized casing
14. High gas pressure regulator (shipped loose for inlet pressures over 1 PSIG).
15. Circuit analyzer trouble shooting lights
16. Electronic time clock
17. Remote control panel.
18. Timed freeze protection
19. On-Off night setback thermostat
20. Smoke detector
21. Mixed air temperature controller for mixing dampers.
22. Manual potentiometer controller for mixing dampers.
23. Pressure control system for mixing dampers.
24. TracRite DDC Control System.

# TAJ Guide Specifications



Base Bid Temprite Model TAJ \_\_\_\_\_ (Single) (Double) Air Turnover (Heating) (Heating and Cooling) unit(s) designed to draw return air at floor level and discharge conditioned air near the ceiling. The unit shall be factory fabricated, assembled, wired and tested prior to shipment in accordance with the specification and equipment schedule. The unit will include all components herein and as shown on the drawings. Alternate equipment, equal in design, construction, performance and capacity to unit(s) specified, must be shown with price deduct/add, if any. Approval of alternate equipment will be subject to review of shop drawings. The unit shall be capable of delivering \_\_\_\_\_ SCFM using a \_\_\_\_\_ horsepower ODP motor operating on (115)(230)/1/60 or (208)(230)(460)/3/60.

## CASING

The unit casing shall consist of formed 20 gauge galvanized steel panels suitably reinforced to ensure rigidity. Cabinet construction shall allow unit(s) to be mounted in the vertical arrangement with no external framework.

The inlet section shall have screened and filtered low velocity return air openings on unit at the floor level.

## AIR MOVING SECTION (Choose one)

**Propeller Model** – Each unit shall be supplied with direct drive four-bladed energy efficient propeller fan rated in accordance with AMCA standards. Each propeller fan will be driven by (single)(three) phase motor.

Propeller fan motor shall be mounted on an solid base and wired in flexible conduit to the control panel in the factory.

**Blower Model** – Each unit shall be supplied with centrifugal forward curve, DWDI blower rated in accordance with AMCA standards. The blower is to be mounted on a heavy duty, turned and ground and polished solid steel shaft designed for a maximum operating speed not to exceed 75% of its first critical speed.

The bearings are to be of the heavy-duty industrial pre-lubricated, self aligning type.

Drives shall have a capacity 25% greater than the motor horsepower. The motor sheave shall be of the adjustable pitch type.

The fan motor shall be mounted on an adjustable base and wired in flexible conduit to the control panel in the factory.

**Note: TAJ not approved for installations in Canada.**

## INDIRECT GAS FIRED SECTION

The entire primary heat transfer surface, headers, and secondary heat transfer surface shall be of 300 series stainless steel. The heat exchanger design shall permit unrestricted lateral and peripheral expansion during the heating and cooling cycle. The flue gas travel shall be of three-pass design, with no internal baffles. The surface temperature of the heat exchanger shall not exceed 75% of its scaling temperature when operating at rated capacity. The heat exchanger shall be rated at a minimum of 80% efficiency at rated output. A pressure relief door complete with an observation window to view the complete flame and pilot shall be provided.

## BURNER

The gas burner shall be of the power type, complete with combination redundant gas valve, ignition control package, integral combustion air blower with totally enclosed motor, integral combustion air proving switch, and removable “gas gun” assembly. The primary air adjustment control shall be on outside of burner with indicator for easy flame adjustment. Burner and controls shall be capable of delivering \_\_\_\_\_ MBH output firing on (natural gas) (propane) at an inlet pressure of \_\_\_\_\_ (inches water column) (PSIG) and in accordance with manufacturer’s standard requirements. Burner and controls shall be arranged for On-Off control.

## COOLING COIL SECTION

Two three row (DX) (CW) cooling coils sized for \_\_\_\_\_ tons cooling with copper tubes, aluminum fins and galvanized steel casing. Headers to be non-ferrous with vents, drains and suitable for 200 psi working pressure. Coils shall be mounted in an “A” coil arrangement with insulated stainless steel drain pan under each coil. Coil velocity shall not exceed 520 FPM. Section will be furnished with 1”, 1 1/2 # fiberglass insulation pin-spotted to casing.

## DISCHARGE PLENUM (Choose one)

**Heating Model** – Unit shall have low velocity discharge air plenum with screens on three sides.

**Heating and Cooling Model** – A discharge plenum with aluminum high velocity discharge grilles on three sides will be provided. The plenum will be furnished with 1”, 1 1/2 # fiberglass insulation pin-spotted to casing. Discharge grilles shall be sized at the factory to provide discharge velocity required for proper air circulation in conditioned space.

# : TAJ Guide Specifications



## ELECTRICAL CONTROLS

A NEMA 1 control panel complete with hinged access door shall be mounted on unit. All control components are to be labeled and individually wired to a numbered terminal strip to aid in servicing. All wiring shall be color coded and number tagged at each end to match the control diagram supplied. Full operating and maintenance instructions shall accompany each unit. All wiring between the controls shall be run in flexible conduit. All electrical components shall bear the U.L. label. The control system shall include but not be limited to the following components required for automatic operation:

- control circuit transformer
- fan motor starters, overloads and sub-circuit fuses
- control circuit fuses
- control relays
- electronic flame supervision
- high limit switch
- heavy duty ignition transformer

## OPTIONAL EQUIPMENT & CONTROLS

1. One factory mounted damper for 0 - 25% of winter outside air with two position motor.
2. Two factory mounted mixing dampers for 0 - 100% control of winter outside air with two position motor(s).
3. Discharge Plenum Extension
4. Disconnect switch
5. Field mounted, heavy duty, non-clogging blade draft inducer fan complete with direct drive motor.
6. Painted galvanized casing
7. High gas pressure regulator (shipped loose for inlet pressures over  $\frac{1}{2}$  PSIG).
8. Electronic time clock
9. Timed freeze protection
10. On-Off night setback thermostat
11. Smoke detector
12. Discharge plenum with four sided discharge.



## Efficient Gas-Fired Heating Systems

### Choose Temprite Gas Fired Air Turnover systems for Your Warehouse

- Heat large or small spaces efficiently by “reclaiming” stratified heat
- Constantly recirculate room air for even temperature distribution
- Eliminate cold floor condensation
- Low operating and maintenance costs
- Optional DX or chilled water cooling
- Simple, inexpensive installation
- Temprite, a leader in research, engineering, and customer service since 1963
- AMCA standards to insure rated airflow

Temprite

[www.tempriteheating.com](http://www.tempriteheating.com)

4830 Transport Drive Dallas TX 75247

Telephone 214.638.6010

Fax 214.905.0806