

PANEL RADIATOR

Submittal

PR2F-1

Specification

PR2F-1 to PR2F-10

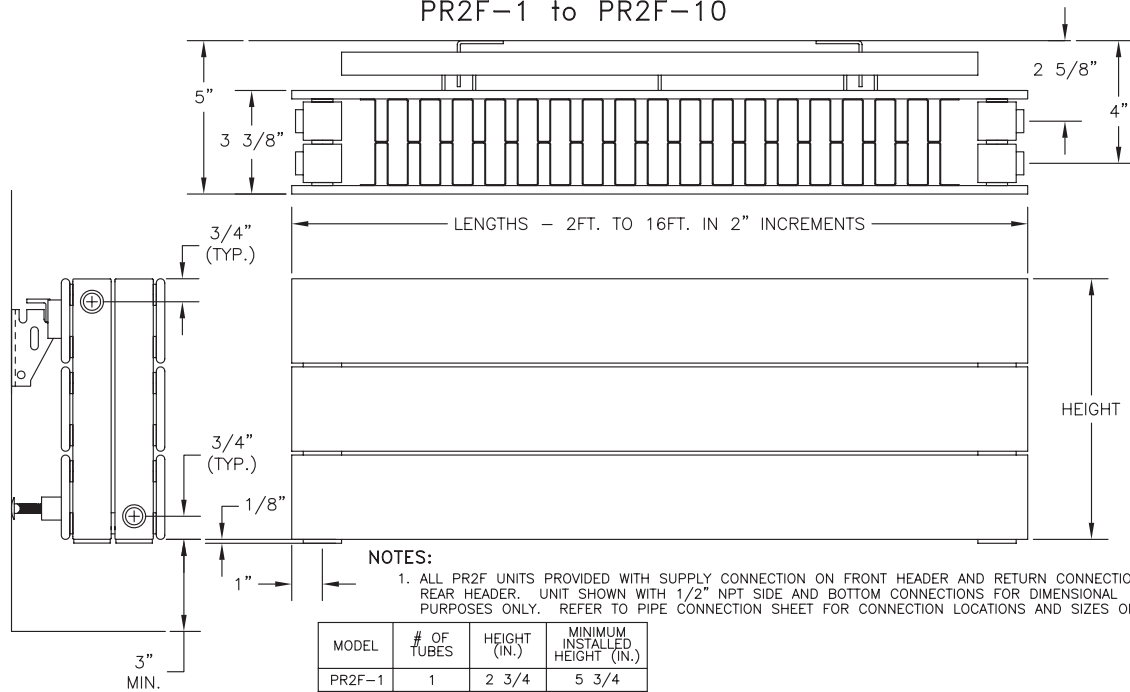

MODEL	# OF TUBES	HEIGHT (IN.)	MINIMUM INSTALLED HEIGHT (IN.)
PR2F-1	1	2 3/4	5 3/4
PR2F-2	2	5 3/4	8 3/4
PR2F-3	3	8 5/8	11 5/8
PR2F-4	4	11 1/2	14 1/2
PR2F-5	5	14 3/8	17 3/8
PR2F-6	6	17 1/4	20 1/4
PR2F-7	7	20 1/4	23 1/4
PR2F-8	8	23 1/8	26 1/8
PR2F-9	9	26 1/8	29 1/8
PR2F-10	10	29	32

CAT-75574B

MODEL TYPE	BTU/Ft/Hr @ LISTED AWT & 65°F EAT								
	215° F	190° F	180° F	170° F	160° F	150° F	140° F	130° F	120° F
PR2F 01	979	769	689	612	537	465	395	327	263
PR2F 02	1589	1247	1118	993	872	754	640	531	427
PR2F 03	2019	1584	1421	1261	1108	958	813	675	542
PR2F 04	2417	1897	1701	1510	1326	1147	974	808	649
PR2F 05	3094	2498	2177	1933	1697	1457	1246	1034	831
PR2F 06	3470	2723	2443	2168	1904	1646	1398	1160	932
PR2F 07	3846	3018	2707	2403	2110	1824	1549	1286	1033
PR2F 08	4211	3304	2963	2631	2310	1997	1696	1408	1131
PR2F 09	4432	3478	3119	2769	2431	2102	1785	1481	1190
PR2F 10	4644	3645	3269	2901	2548	2203	1871	1552	1247

STERLING
 COMMERCIAL HYDRONIC PRODUCTS
 260 North Elm St., Westfield, MA 01085
 (413) 564-5535 Fax: (413) 562-8437
 www.sterlingheat.com

PROJECT: _____ DATE: _____
 LOCATION: _____
 ARCHITECT: _____
 ENGINEER: _____
 CONTRACTOR: _____
 PO NUMBER: _____

TYPICAL WALL MOUNTED INSTALLATION

WALL MOUNTING – TYPICAL INSTALLATION
WALL MOUNTING: PR, PR2, PR2F

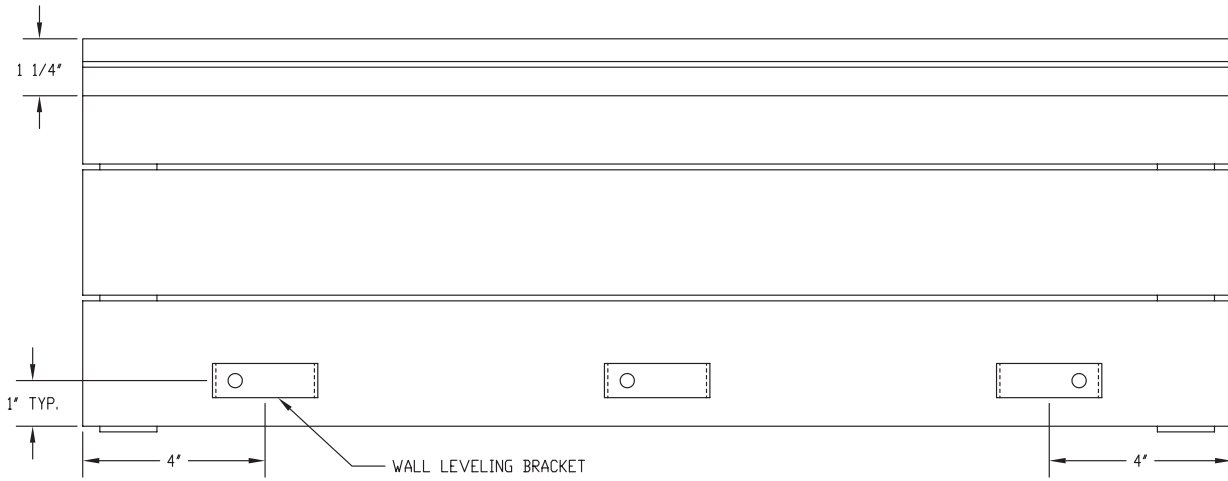

TYPICAL LEVELING BRACKET INSTALLATION (BACKVIEW)

PANEL LENGTH	QTY. OF BRACKETS
24' - 60'	2 PCS
62' - 138'	3 PCS
140' - 236'	4 PCS
238' - 240'	5 PCS

A LEVELING BOLT IS SUPPLIED FOR EACH BRACKET

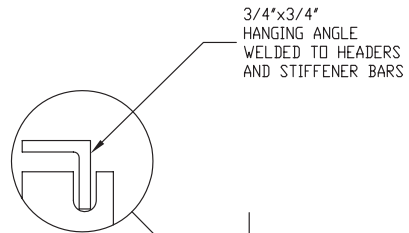

TYPICAL WALL MOUNTING BRACKET INSTALLATION

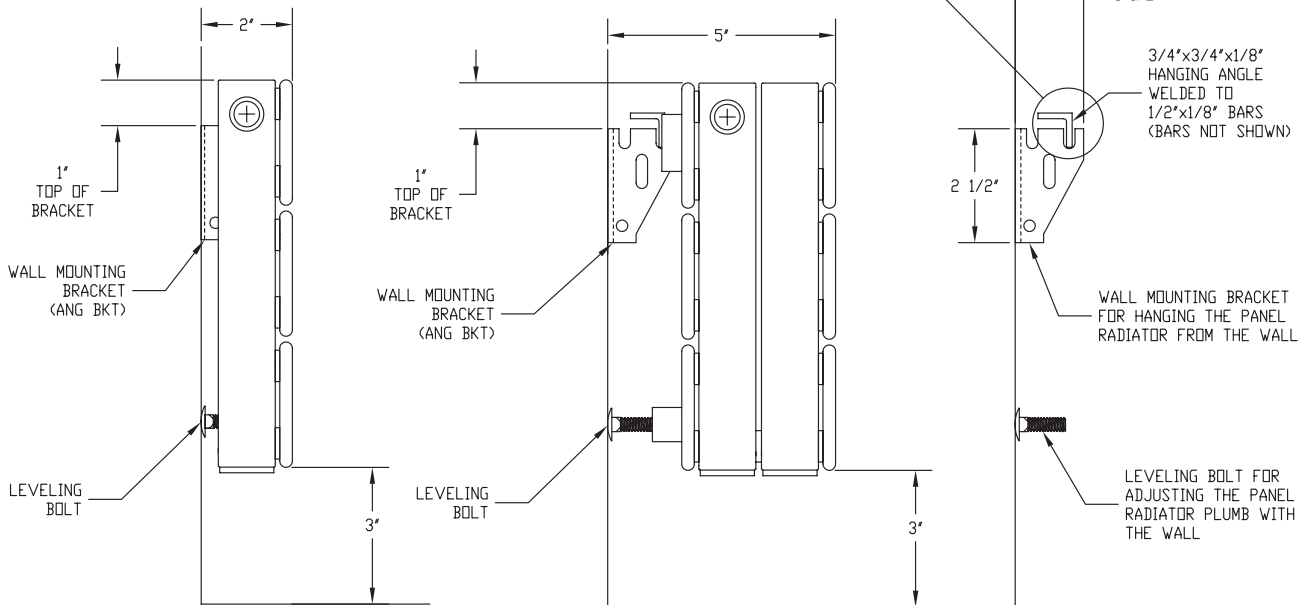

TYPICAL FREE STANDING PEDESTAL MOUNTED INSTALLATION

PEDESTAL MOUNTING FREE STANDING FLOOR MOUNT PR2, PR2F & PR3F

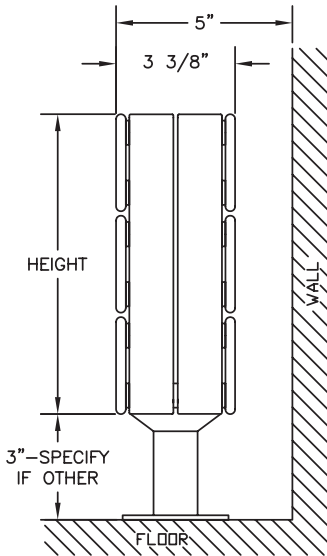
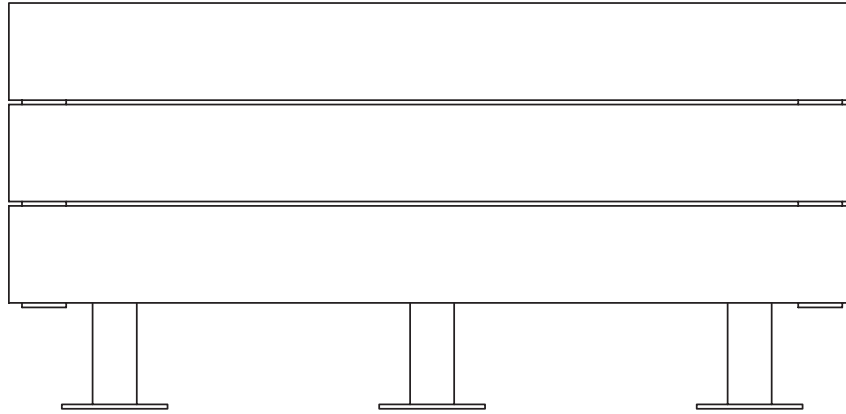

FREE STANDING FLOOR MOUNT FOR "PR2" AND "PR2F" UNITS

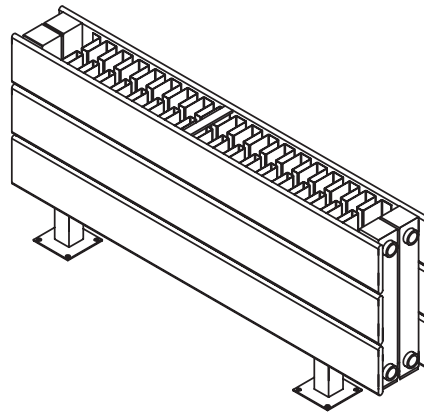

PANEL LENGTH	QTY. OF BRACKETS
24" - 60"	2 PCS
62" - 138"	3 PCS
140" - 192"	4 PCS

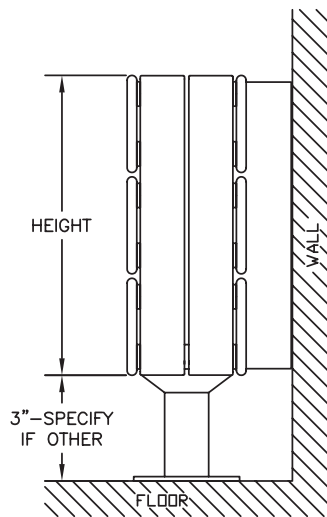

FREE STANDING FLOOR MOUNT FOR "PR3F" UNITS

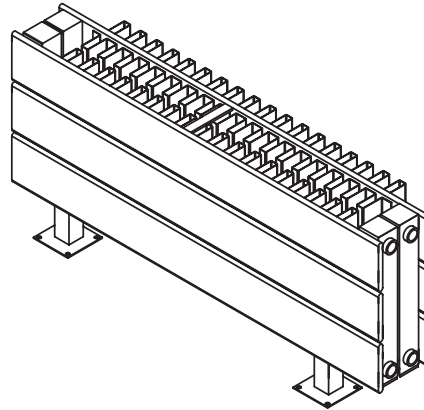

PANEL MODEL	HEIGHT
PR2-1, PR2F-1, PR3F-1	2-3/4"
PR2-2, PR2F-2, PR3F-2	5-3/4"
PR2-3, PR2F-3, PR3F-3	8-5/8"
PR2-4, PR2F-4, PR3F-4	11-1/2"

ONLY AVAILABLE UP TO 4 TUBES TALL

CAT-75589B

STANDARD PIPING CONNECTION LOCATIONS

PR2, PR2F, PR3F PIPING OPTIONS

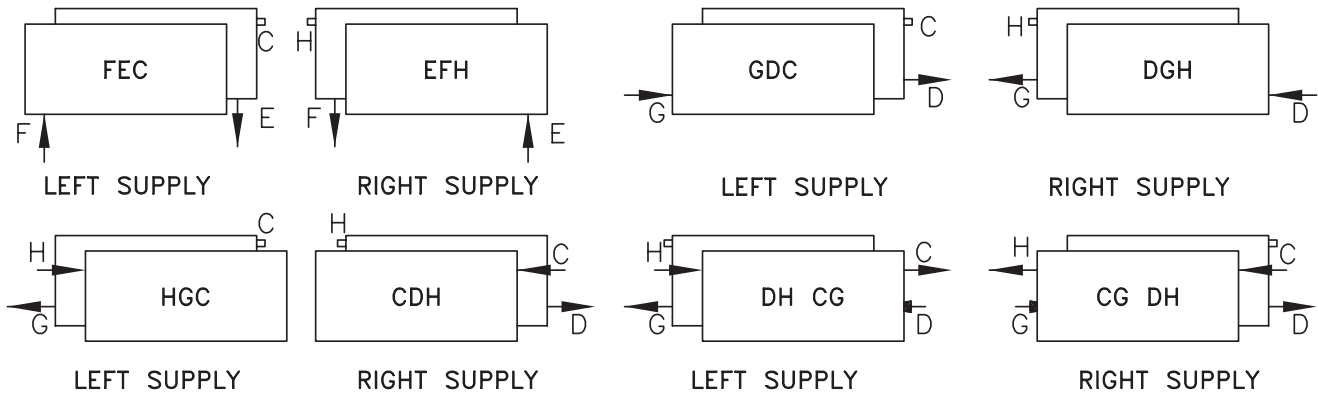

OPPOSITE END SERIES

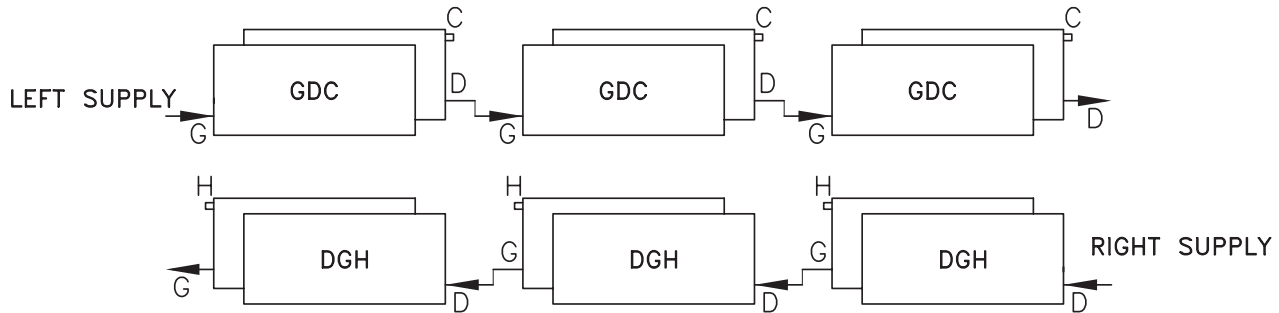

NOTES:

- VENT ON EACH PANEL
- CAN ELIMINATE COSTLY RISERS
- LOWER PD THAN SAME END SERIES
- UP TO 7 RADIATORS (100 FT) IN SERIES OPPOSITE END
- EXPANSION COMPENSATION PIPING TO BE PROVIDED BY OTHERS

SAME END SERIES

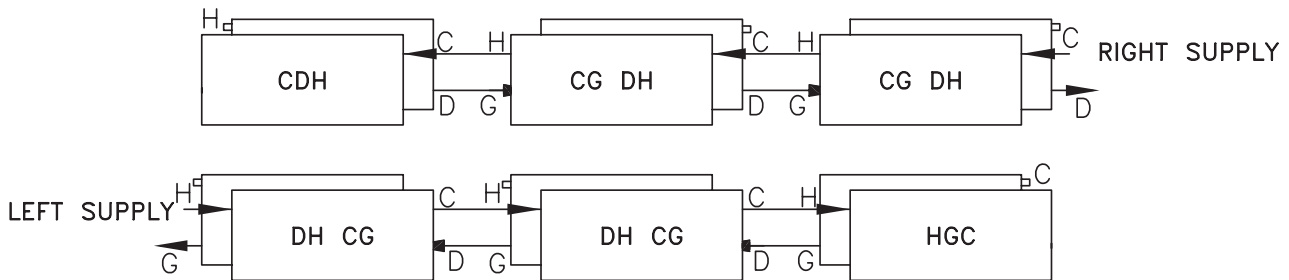

NOTES:

- SAME AWT OVER THE ENTIRE SAME END SERIES
- CAN ELIMINATE COSTLY RISERS
- HIGHER PD THAN OPPOSITE END SERIES
- NO MORE THAN 3 RADIATORS IN SERIES SAME END
- EXPANSION COMPENSATION PIPING TO BE PROVIDED BY OTHERS

Model PR2F

PANEL RADIATOR SPECIFICATIONS

Specifications

Provide steel double panel radiators of the lengths and in locations as indicated, and of capacities, style, and having accessories as scheduled. The double heating panel radiation shall be of one-piece all-welded steel construction, consisting of a pair of flattened water tube panels welded to headers at each end. Continuous strips of steel corrugated fins are to be welded to the inside of each panel, to increase the convective output of the radiator. The fins shall start at no less than 3" from the end of the radiator, and shall have no less than 32 fins per foot. The radiators may include an optional integral heavy gauge all-welded perforated top grille, which will cover the top of all of the finned areas, when specified.

All radiator header pipes are square 0.109" minimum wall thickness. The headers shall include all necessary inlet, outlet and vent connections as required. Standard connection sizes are 1/2" NPT tapered thread for supply and return piping, and 1/8" for the vent connection. Internal baffling is provided where required for proper water flow. Option 29, 3/4" NPT connections are available at an additional cost, when specified.

The radiant heating panels shall be available in lengths from 2'-0" to 16'-0" in two inch even increments without the need for splicing. The panel radiation shall be capable of being mounted to typical stud wall construction without additional blocking or strapping. Appropriate wall mounting brackets shall be provided with the radiation. Optional floor mounting pedestal brackets (for panels up to 4 tubes high) may be provided at an additional cost when specified. Panel radiation expansion shall not exceed 1/64" per foot of radiation at 215°F. The installer shall provide adequate expansion compensation for each radiator.

Pressure Ratings:

Pressure ratings for the radiation shall be as follows:

LOW (Standard)- .048" minimum wall thickness. Working pressure 56-PSI maximum, Test Pressure-74 PSI maximum

OR

MEDIUM (Optional)- .058" minimum wall thickness. Working pressure 85-PSI maximum, Test Pressure-110 PSI maximum

OR

HIGH (Optional)- .078" minimum wall thickness. Working pressure 128-PSI maximum, Test Pressure 184 PSI maximum

Finishes:

The panel radiation shall be cleaned and phosphatized in preparation for the powder coat finish. The radiation is then finish painted with a gloss powder coat finish, for a total paint thickness of 2-3 mils (0.002" - 0.003"). The color shall be selected from Sterling's standard commercial colors. Optional custom colors shall be available at and additional cost.

Warranty:

A 5-Year Limited Warranty covers all Sterling panel radiators.

Options:

Dual header panel radiators (up to 4 tubes tall) may be provided with floor-mounted pedestal brackets at an additional cost when specified. Ribbed pipe cover trims (up to 4 tubes high), finished to match the radiators shall be provided at an additional cost when specified.

Optional integral heavy gauge all-welded perforated top grille is available at an additional cost, when specified.