

PANEL RADIATOR

Submittal

PR2-1

Specification

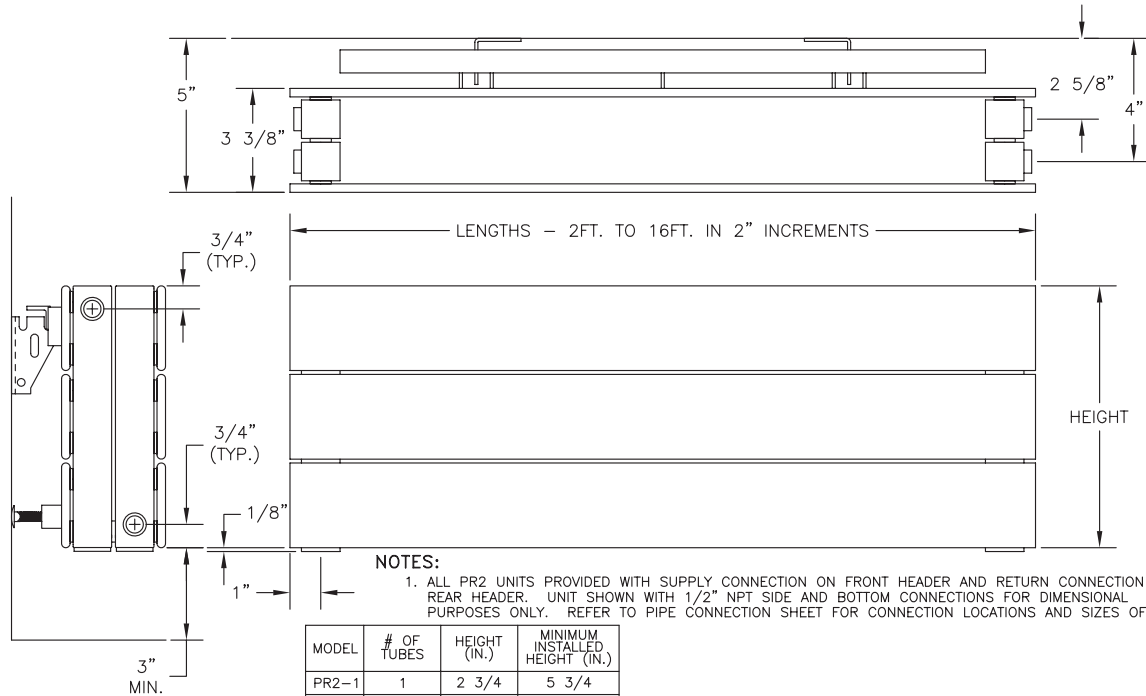

MODEL	# OF TUBES	HEIGHT (IN.)	MINIMUM INSTALLED HEIGHT (IN.)
PR2-1	1	2 3/4	5 3/4
PR2-2	2	5 3/4	8 3/4
PR2-3	3	8 5/8	11 5/8
PR2-4	4	11 1/2	14 1/2
PR2-5	5	14 3/8	17 3/8
PR2-6	6	17 1/4	20 1/4
PR2-7	7	20 1/4	23 1/4
PR2-8	8	23 1/8	26 1/8
PR2-9	9	26 1/8	29 1/8
PR2-10	10	29	32

CAT-75573B

MODEL TYPE	BTU/Ft/Hr @ LISTED AWT & 65°F EAT								
	215° F	190° F	180° F	170° F	160° F	150° F	140° F	130° F	120° F
PR2 01	388	304	273	242	213	184	156	130	104
PR2 02	766	601	539	478	420	363	308	256	206
PR2 03	1129	886	795	705	619	536	455	377	303
PR2 04	1480	1162	1042	925	812	702	596	495	398
PR2 05	1834	1439	1291	1146	1006	870	739	613	493
PR2 06	2190	1719	1542	1369	1202	1039	882	732	588
PR2 07	2554	2004	1797	1596	1401	1211	1029	854	686
PR2 08	2917	2289	2053	1823	1600	1384	1175	975	784
PR2 09	3278	2573	2307	2048	1798	1555	1321	1096	881
PR2 10	3631	2849	2556	2269	1992	1722	1463	1214	975



STERLING

COMMERCIAL HYDRONIC PRODUCTS

260 North Elm St., Westfield, MA 01085

(413) 564-5535 Fax: (413) 562-8437

www.sterlingheat.com

PROJECT: _____ DATE: _____

LOCATION: _____

ARCHITECT: _____

ENGINEER: _____

CONTRACTOR: _____

PO NUMBER: _____

TYPICAL WALL MOUNTED INSTALLATION

WALL MOUNTING – TYPICAL INSTALLATION
 WALL MOUNTING: PR, PR2, PR2F

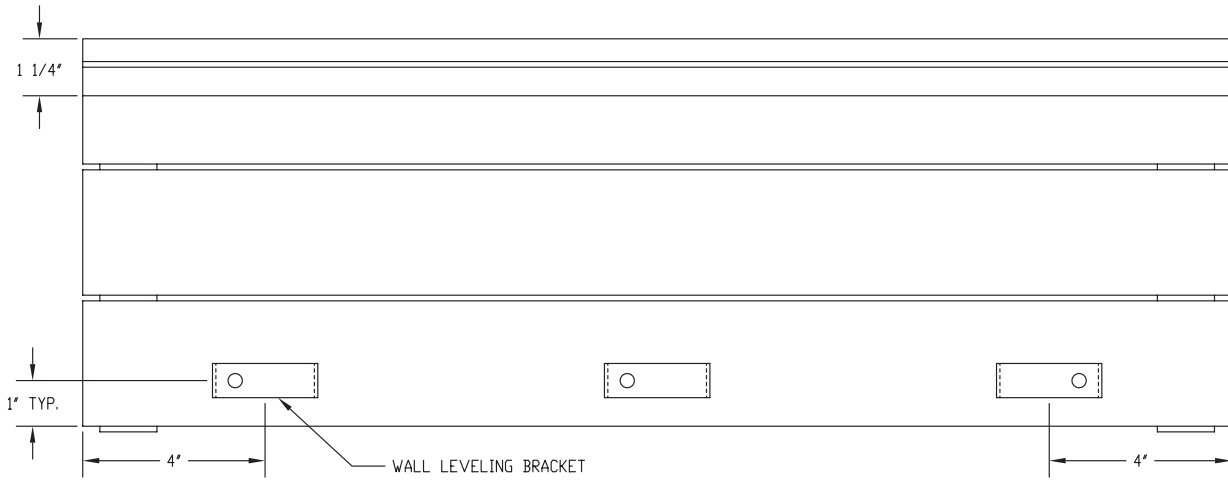

TYPICAL LEVELING BRACKET INSTALLATION (BACKVIEW)

PANEL LENGTH	QTY. OF BRACKETS
24' - 60'	2 PCS
62' - 138'	3 PCS
140' - 236'	4 PCS
238' - 240'	5 PCS

A LEVELING BOLT IS SUPPLIED FOR EACH BRACKET

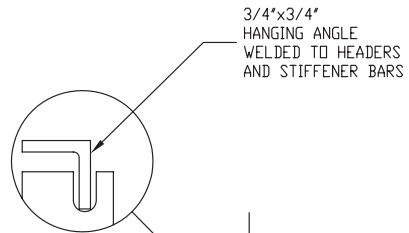

3/4"x3/4"
 HANGING ANGLE
 WELDED TO HEADERS
 AND STIFFENER BARS

TYPICAL WALL MOUNTING BRACKET INSTALLATION

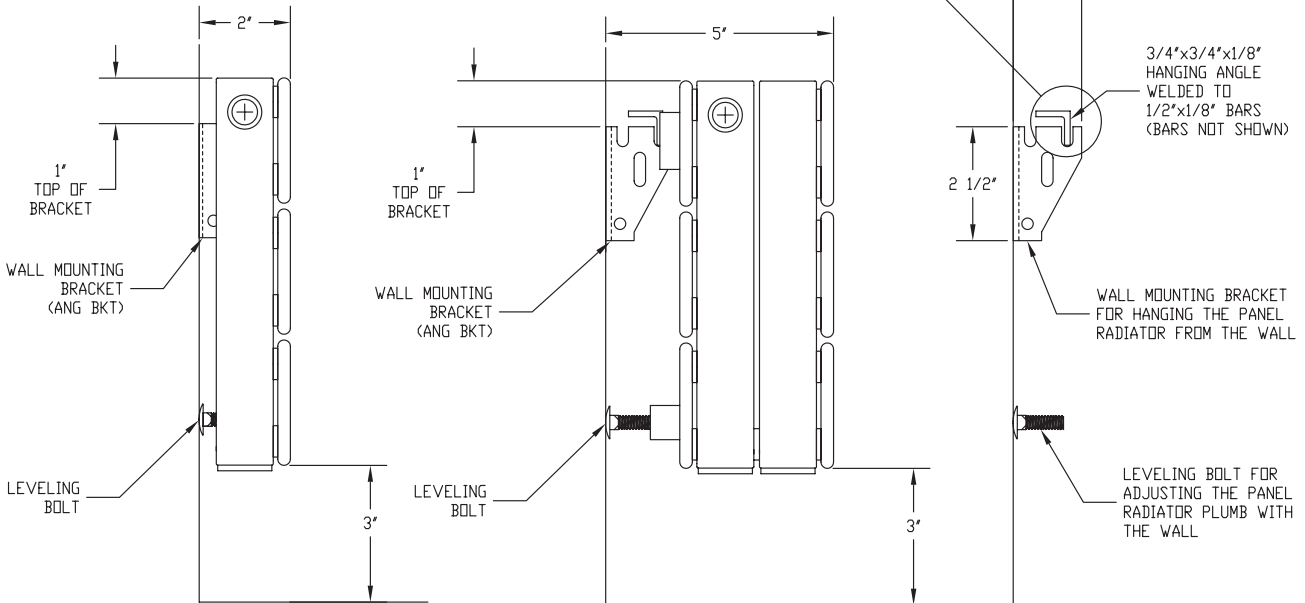

TYPICAL FREE STANDING PEDESTAL MOUNTED INSTALLATION

PEDESTAL MOUNTING FREE STANDING FLOOR MOUNT PR2, PR2F & PR3F

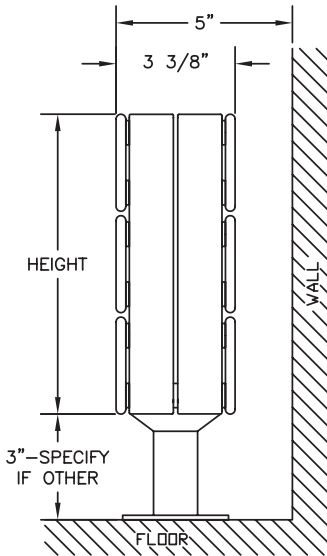
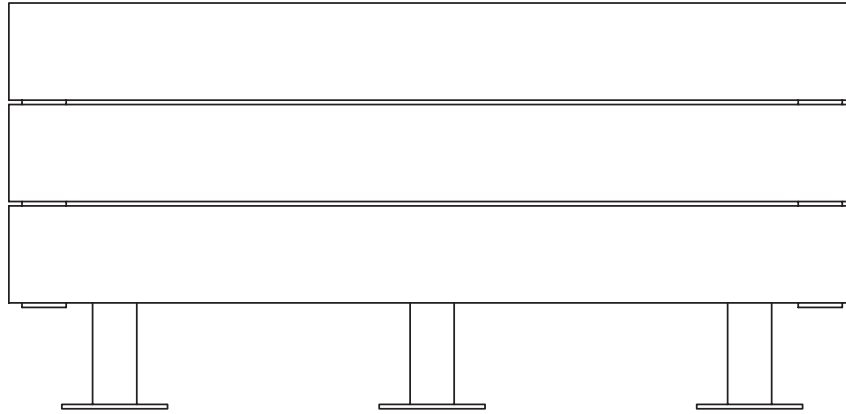

FREE STANDING FLOOR MOUNT FOR "PR2" AND "PR2F" UNITS

PANEL LENGTH	QTY. OF BRACKETS
24" - 60"	2 PCS
62" - 138"	3 PCS
140" - 192"	4 PCS

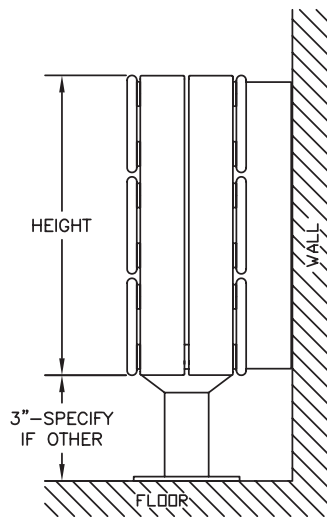
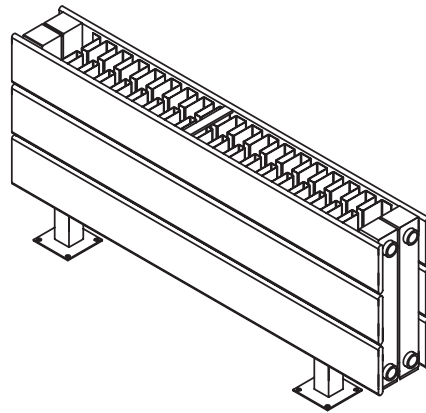

FREE STANDING FLOOR MOUNT FOR "PR3F" UNITS

PANEL MODEL	HEIGHT
PR2-1, PR2F-1, PR3F-1	2-3/4"
PR2-2, PR2F-2, PR3F-2	5-3/4"
PR2-3, PR2F-3, PR3F-3	8-5/8"
PR2-4, PR2F-4, PR3F-4	11-1/2"

ONLY AVAILABLE UP TO 4 TUBES TALL

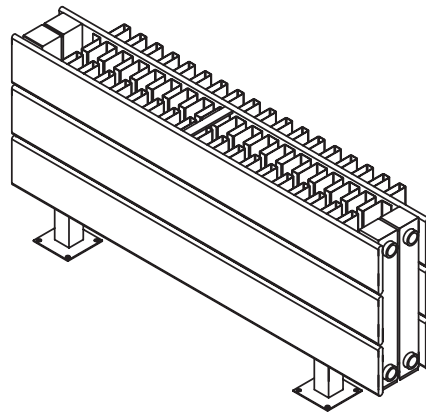

CAT-75589B

STANDARD PIPING CONNECTION LOCATIONS

PR2, PR2F, PR3F PIPING OPTIONS

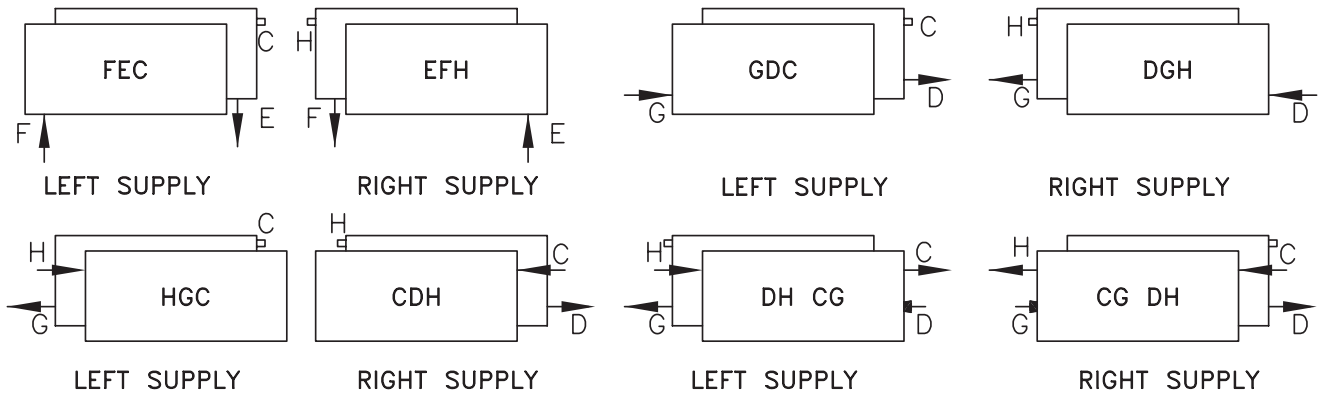

OPPOSITE END SERIES

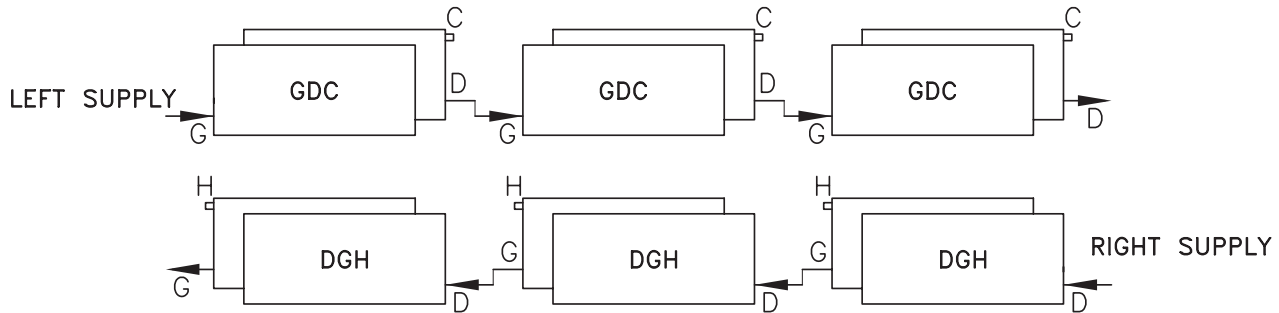

- NOTES:
- VENT ON EACH PANEL
 - CAN ELIMINATE COSTLY RISERS
 - LOWER PD THAN SAME END SERIES
 - UP TO 7 RADIATORS (100 FT) IN SERIES OPPOSITE END
 - EXPANSION COMPENSATION PIPING TO BE PROVIDED BY OTHERS

SAME END SERIES

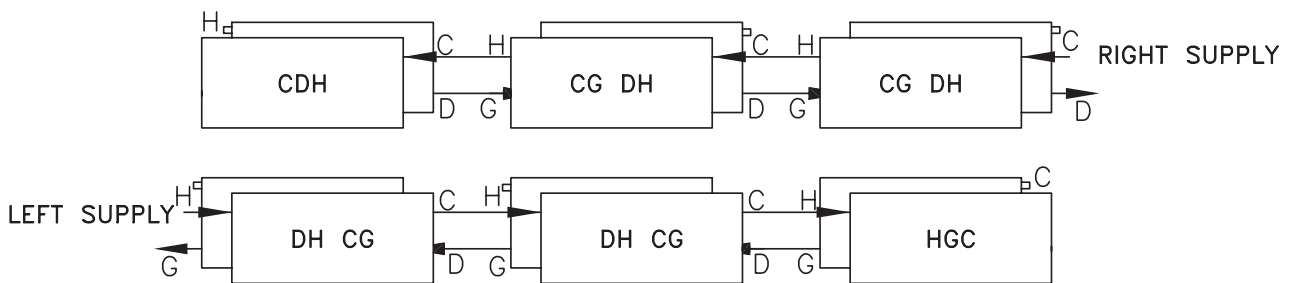

- NOTES:
- SAME AWT OVER THE ENTIRE SAME END SERIES
 - CAN ELIMINATE COSTLY RISERS
 - HIGHER PD THAN OPPOSITE END SERIES
 - NO MORE THAN 3 RADIATORS IN SERIES SAME END
 - EXPANSION COMPENSATION PIPING TO BE PROVIDED BY OTHERS

Model PR2

PANEL RADIATOR SPECIFICATIONS

Specifications

Provide steel double panel radiators of the lengths and in locations as indicated, and of capacities, style, and having accessories as scheduled. The double heating panel radiation shall be of one-piece all-welded steel construction, consisting of a pair of flattened water tube panels welded to headers at each end. The radiator may include an optional integral heavy gauge all-welded perforated top grille, when specified.

All radiator header pipes are square 0.109" minimum wall thickness. The headers shall include all necessary inlet, outlet and vent connections as required. Standard connection sizes are ½" NPT tapered thread for supply and return piping, and 1/8" for the vent connection. Internal baffling is provided where required for proper water flow. Optional 29, ¾" NPT connections are available at an additional cost, when specified.

The radiant heating panels shall be available in lengths from 2'-0" to 16'-0" in two inch even increments without the need for splicing. The panel radiation shall be capable of being mounted to typical stud wall construction without additional blocking or strapping. Appropriate wall mounting brackets shall be provided with the radiation. Optional floor mounting pedestal brackets (for panels up to 4 tubes high) may be provided at an additional cost when specified. Panel radiation expansion shall not exceed 1/64" per foot of radiation at 215°F. The installer shall provide adequate expansion compensation for each radiator.

Pressure Ratings:

Pressure ratings for the radiation shall be as follows:

LOW (Standard)- .048" minimum wall thickness. Working pressure 56-PSI maximum, Test Pressure-74 PSI maximum

OR

MEDIUM (Optional)- .058" minimum wall thickness. Working pressure 85-PSI maximum, Test Pressure-110 PSI maximum

OR

HIGH (Optional)- .078" minimum wall thickness. Working pressure 128-PSI maximum, Test Pressure 184 PSI maximum

Finishes:

The panel radiation shall be cleaned and phosphatized in preparation for the powder coat finish. The radiation is then finish painted with a gloss powder coat finish, for a total paint thickness of 2-3 mils (0.002" - 0.003"). The color shall be selected from Sterling's standard commercial colors. Optional custom colors shall be available at and additional cost.

Warranty:

A 5-Year Limited Warranty covers all Sterling panel radiators.

Options:

Dual header panel radiators (up to 4 tubes tall) may be provided with floor-mounted pedestal brackets at an additional cost when specified. Ribbed pipe cover trims (up to 4 tubes high), finished to match the radiators shall be provided at an additional cost when specified.

Optional integral heavy gauge all-welded perforated top grille is available at an additional cost, when specified.