

CONVECTOR

Submittal

SW-A
Slope Top Cabinet
Wall Mounted

Specification

SW-A Bottom Inlet

FRONT and LINER:

STYLE: Slope Outlet
OUTLET: Stamped Louvers
Pencil Proof

LENGTHS: 20" thru 64" in 4" Increments
MAT'L: Cabinet Front and Liner
 18 Ga./20 Ga. CRS STD.
 18 Ga./18 Ga. CRS (Opt'l)
 16 Ga./20 Ga. CRS (Opt'l)
 16 Ga./18 Ga. CRS (Opt'l)
 16 Ga./16 Ga. CRS (Opt'l)
 14 Ga./20 Ga. CRS (Opt'l)
 14 Ga./18 Ga. CRS (Opt'l)
 14 Ga./16 Ga. CRS (Opt'l)
 14 Ga./14 Ga. CRS (Opt'l)

FINISH: Prime Finish Std.
 Baked Enamel (Opt'l)
 18 Ga./20 Ga. SS (Opt'l)
 18 Ga./18 Ga. SS (Opt'l)
 16 Ga./20 Ga. SS (Opt'l)
 16 Ga./18 Ga. SS (Opt'l)
 16 Ga./16 Ga. SS (Opt'l)

ELEMENT:

COIL: Bronze Header 3/4" NPT
w/Copper Tube/Alum Fins
(Mechanically Expanded).

HEADER CONNECTIONS:

Single Header Both Ends Std.
 Single Inlet 1 End / Dual Inlet
1 End (Opt'l)
 Dual Inlet Both Ends (Opt'l)

OPTIONAL ACCESSORIES:

DAMPER: Damper Blades Factory Installed
 Knob Damper (Opt'l)
 Tamper Resistant (Opt'l)

ACCESS DOORS:

(Opt'l)

INSULATION:

Back Only (Opt'l)
 Back, Sides, Top (Opt'l)

PIPING KNOCKOUT:

(Opt'l)

4" END POCKETS:

LH (Opt'l)
 RH (Opt'l)
 Both Ends (Opt'l)

PERFORATED FRONT: Consult Factory

16 Ga. (Opt'l)
 14 Ga. (Opt'l)

SW-A Bottom Inlet

TYPE SW-A

MODEL	D	L	H	B	J
4xx-14	4-1/4	20,24,28,	14	2-1/8	2
4xx-18		32,36,40,	18		
4xx-20		44,48,52,	20		
4xx-26		56,60,64,	26		
4xx-32			32		
6xx-14	6-1/4	20,24,28,	14	3-1/8	4
6xx-18		32,36,40,	18		
6xx-20		44,48,52,	20		
6xx-26		56,60,64,	26		
6xx-32			32		
8xx-14	8-1/4	20,24,28,	14	4-1/8	6
8xx-18		32,36,40,	18		
8xx-20		44,48,52,	20		
8xx-26		56,60,64,	26		
8xx-32			32		

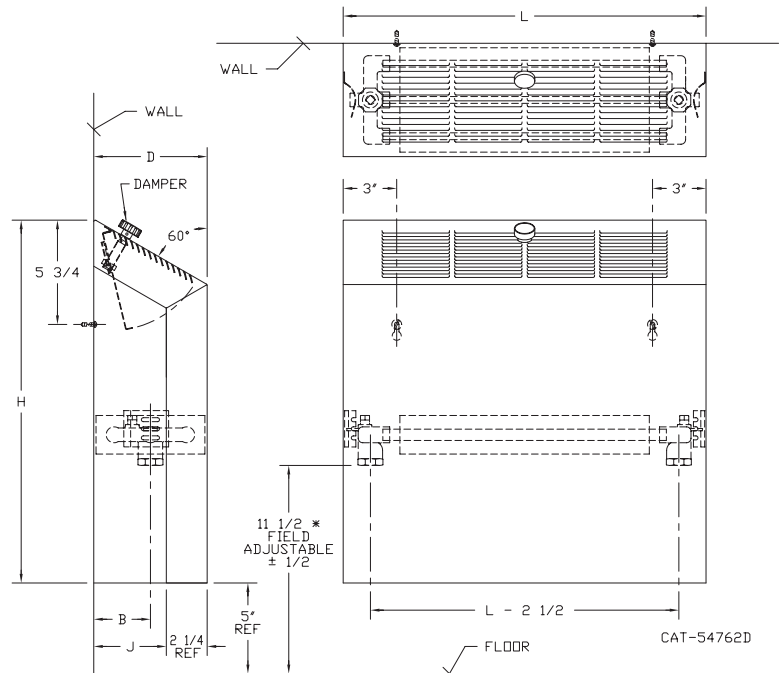

NOTE: When adding end pockets, liner and front length increase.



COMMERCIAL HYDRONIC PRODUCTS

260 North Elm St., Westfield, MA 01085

(413) 564-5535 Fax: (413) 562-8437

www.sterlingheat.com



PROJECT: _____ DATE: _____

LOCATION: _____

ARCHITECT: _____

ENGINEER: _____

CONTRACTOR: _____

PO NUMBER: _____

STEAM RATINGS IN BTU/H (215°F at 65°F EAT)

DEPTH IN INCHES	LENGTH IN INCHES	SLOPE TOP, WALL MOUNTED, NOMINAL HEIGHT TYPE SW-A				
		14"	18"	20"	26"	32"
4	20	2930	3120	3215	3335	3505
	24	3720	3960	4080	4250	4415
	28	4490	4775	4895	5110	5305
	32	5305	5640	5760	6050	6290
	36	6070	6455	6625	6960	7250
	40	6840	7320	7510	7850	8110
	44	7630	8135	8350	8735	9070
	48	8400	8975	9190	9625	9985
	52	9145	9745	9935	10440	10850
	56	9935	10655	10850	11400	11830
	60	10705	11400	11615	12190	12815
64	11495	12310	12530	13150	13920	
		14"	18"	20"	26"	32"
6	20	4510	4970	5090	5425	5690
	24	5710	6290	6480	6960	7175
	28	6890	7560	7750	8330	8690
	32	8110	8905	9120	9840	10130
	36	9290	10175	10490	11255	11615
	40	10490	11470	11810	12670	13150
	44	11665	12790	13105	14160	14665
	48	12840	14040	14470	15550	16105
	52	14015	15290	15720	16895	17590
	56	15215	16655	17135	18410	19150
	60	16345	17880	18360	19730	20570
64	17570	19270	19775	21265	22080	
		14"	18"	20"	26"	32"
8	20	5760	6120	6310	6770	7030
	24	7345	7825	8040	8665	9000
	28	8880	9410	9650	10415	10825
	32	10440	11135	11400	12310	12790
	36	12050	13250	13105	14135	14690
	40	13560	14425	14830	15985	16585
	44	15120	16030	16510	17760	18430
	48	16680	17710	17905	19610	20375
	52	18190	19250	19750	21335	22225
	56	19750	21000	21550	23255	24215
	60	21290	22510	23110	24960	26040
64	22895	24265	24935	26880	28010	

Correction factors for BTU performance at different Average Water Temperatures, use correction factors from Table 3 of the Correction Factors page.

For other applicable correction factors see the Correction Factors page.

CONVECTOR BTU CORRECTION FACTORS

Table 3

CONVECTOR CORRECTION FACTORS Based on Section 35.4 ASHRAE HVAC Systems and Equipment					
AVERAGE WATER TEMPERATURE (°F)	ENTERING AIR TEMPERATURE (°F)				
	(STD)				
	55°	60°	65°	70°	75°
100°	0.17	0.14	0.12	0.09	0.07
110°	0.23	0.20	0.17	0.14	0.12
120°	0.29	0.26	0.23	0.20	0.17
130°	0.35	0.32	0.29	0.26	0.23
140°	0.43	0.39	0.35	0.32	0.29
150°	0.50	0.46	0.43	0.39	0.35
160°	0.58	0.54	0.51	0.47	0.43
170°	0.67	0.63	0.58	0.54	0.51
180°	0.76	0.71	0.67	0.63	0.58
190°	0.85	0.81	0.76	0.71	0.67
200°	0.95	0.90	0.85	0.81	0.76
210°	1.05	1.00	0.95	0.90	0.85
215° (STD)	1.10	1.05	1.00	0.95	0.90
220°	1.15	1.10	1.05	1.00	0.95
230°	1.26	1.20	1.15	1.10	1.05
240°	1.37	1.32	1.26	1.21	1.15
250°	1.47	1.43	1.37	1.32	1.27

Table 4

CORRECTION FACTORS FOR STEAM PRESSURES OTHER THAN 1 PSI GAUGE*						
FACTOR	PRESSURE PSI GAUGE					
	5	10	15	20	25	50
BTU PER SQ. FT.	1.12	1.25	1.36	1.46	1.56	1.93
	269	301	327	351	374	463

*Apply factors shown above to the ratings shown on the 215°F ratings page.

Note: Max Recommended operating pressure 150 PSIG, (365.9°F).
For conversion from steam to hot water, use correction factors shown in table 3.

Table 5

CORRECTION FACTORS FOR ACCESS DOORS								
Length	Free Standing, Non-Recessed Non-Standard Access Door Locations				Semi-Recessed or Fully Recessed Non-Standard Access Door Locations			
	3 or 4	3 & 4	5 or 6	5 & 6	3 or 4	3 & 4	5 or 6	5 & 6
	20"	0.940	0.880	0.820	0.650	0.975	0.950	0.925
24"	0.950	0.910	0.860	0.720	0.980	0.960	0.940	0.880
28"	0.960	0.920	0.890	0.770	0.982	0.968	0.948	0.902
32"	0.970	0.940	0.890	0.800	0.985	0.972	0.955	0.918
36"	0.970	0.940	0.920	0.830	0.988	0.975	0.962	0.925
40"	0.970	0.950	0.920	0.850	0.990	0.978	0.970	0.932
44"	0.980	0.950	0.930	0.860	0.990	0.980	0.970	0.940
48"	0.980	0.960	0.940	0.880	0.990	0.982	0.970	0.948
52"	0.980	0.960	0.950	0.890	0.992	0.985	0.978	0.955
56"	0.980	0.960	0.950	0.890	0.992	0.985	0.978	0.955
60"	0.980	0.970	0.950	0.900	0.992	0.985	0.978	0.955
64"	0.980	0.970	0.950	0.910	0.992	0.988	0.978	0.962

Note: Derating factors do not apply to units with end pockets.

Table 6

WATER FLOW IN GPM	PRESSURE LOSS IN FEET OF WATER		
	4 INCH MODELS	6 INCH MODELS	8 INCH MODELS
.25	0.044	—	—
.50	0.160	0.070	0.046
1	0.597	0.270	0.167
2	2.220	1.047	0.616
3	—	2.260	1.367
4	—	3.793	2.380
5	—	—	3.673

Charted figures showing pressure drop through Convectors with forced hot water. Used for determining pressure head requirement. Based on 64" length units, but applicable to shorter units, as most loss is due to headers.

Table 7

CORRECTION FACTORS FOR INLET GRILLES TYPES: FSG-A, SRG-A, RFG-A, FWG-A, PWG-A, SFG-A			
DEPTH	HEIGHT		
	16", 18", 20"	22", 24", 26"	28", 30", 32"
4"	0.97	0.98	0.99
6"	0.94	0.95	0.98
8"	0.91	0.93	0.97

Due to the restriction to air flow, the percentages should be subtracted from the BTU output when inlet grilles are specified.

ADDITIONAL CORRECTION FACTORS ON NEXT PAGE

CONVECTOR BTU CORRECTION FACTORS

GALLONS PER MINUTE OF HOT WATER REQUIRED

Table 8

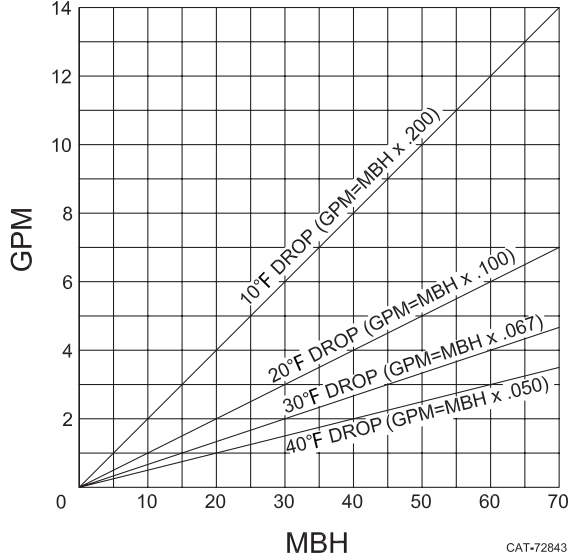

OUTPUT-FLOW RATE CORRECTIONS

Table 9

Convactor Depth	Tubes per Element	Min. Flow Rate (0.25 Ft./Sec.) GPM	MBH Based on T.D. & Min. Flow Rate			
			10TD	20TD	30TD	40TD
4"	2	.15	0.750	1,500	2,250	3,000
6"	3	.225	1.125	2,250	3,375	4,500
8"	4	.30	1.500	3,000	4,500	6,000

NOTE: Table 9 shows MBH which result at specific water temperature drops and minimum water flow rates which are required to maintain turbulent flow within element tubes.

CONVECTOR COIL

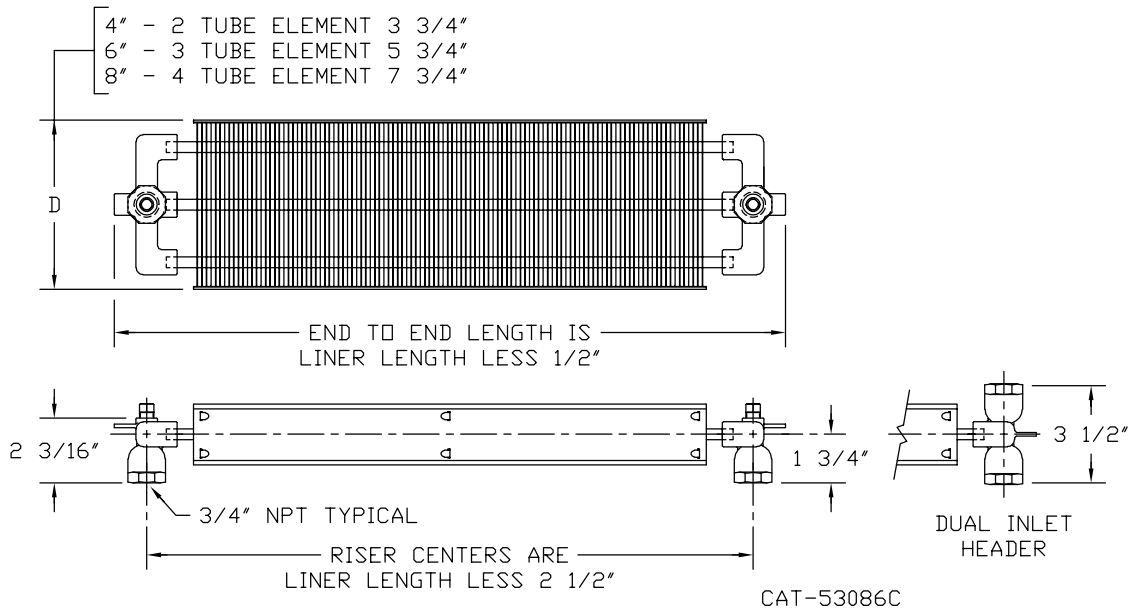

NOTE: When ordering convectors with end pockets always refer to the standard unit length. The overall physical length will increase by 4" for each end pocket. The coil length will remain the standard size. Coil fins are 2-1/2" high by width shown above and are mechanically bonded to copper tube at 6 fins per inch.

