



# MODEL WCSP-G SYSTEM INSTALLATION, OPERATION & MAINTENANCE MANUAL

Central Hydronic Coil Series  
2 to 5 Tons  
Fan Coil Unit/Air Supply  
Components



<b>SECTION 1: INTRODUCTION</b>		Step 5: Installing The Condensate Trap & Line.....	12
SpacePak System Design.....	2	Step 6: Wiring The Unit.....	12, 13
Code Compliance.....	2	Step 7: Installing Air Distribution Components.....	14
Air Distribution Requirements.....	2	<b>SECTION 3: START UP &amp; OPERATION</b>	
Air Distribution Components.....	3	Sequence Of Operation.....	18
Warranty Information.....	Back Cover	Prior To Start-Up.....	19
Shipment of Unit.....	5	System Start-Up & Adjustments.....	19
<b>SECTION 2: SYSTEM INSTALLATION</b>		Factors Affecting the Balance of the System.....	20
Step 1: Locating The Unit.....	5	<b>SECTION 4: MAINTENANCE</b>	
Step 2: Cutting Return Air Opening.....	8	Biannual Maintenance Checklist.....	21
Step 3: Attaching Supply Air Plenum Adaptor.....	9	If System Fails To Operate.....	21
Step 4: Setting The Unit.....	11	Service/Troubleshooting Form.....	22
		Parts List.....	23



# Section 1: INTRODUCTION

The following terms are used throughout this manual to bring attention to the presence of potential hazards or to important information concerning the product:

**▲ DANGER** Indicates an imminently hazardous situation which, if not avoided, will result in death, serious injury or substantial property damage.

**▲ WARNING** Indicates an imminently hazardous situation which, if not avoided, could result in death, serious injury or substantial property damage.

**▲ CAUTION** Indicates an imminently hazardous situation which, if not avoided, may result in minor injury or property damage.

**NOTICE:** Used to notify of special instructions on installation, operation or maintenance which are important to equipment but not related to personal injury hazards.

## SPACEPAK SYSTEM DESIGN

The SpacePak WCSP-G unit is a hydronic fan coil unit which utilizes chilled or heated water from a chiller or boiler to provide the conditioned air through the specially designed prefabricated preinsulated flexible duct system. The system and its basic components operate the same as in any conventional air-to-air cooling system.

The SpacePak system is covered by the following U.S. Patents: 3,507,354; 3,575,234; 3,596,936; 3,605,797; 3,685,329; 4,045,977; 4,698,982; 926,673 and Canadian Patents: 891,292; 923,935; 923,936.

## CODE COMPLIANCE

Fan coil unit installation must conform to the requirements of the local authority having jurisdiction or, in the absence of such requirements, to the National Board of Fire Underwriters regulations. Fan coil unit meets ETL listing requirements.

All electrical wiring must be in accordance with the National Electrical Code ANSI/NFPA No. 70-latest edition and any additional state or local code requirements. If an external electrical source is utilized, the fan coil unit, when installed, must be electrically grounded.

**NOTICE:** It is a requirement of the International Mechanical Code (307.2.3) to install a secondary drain or an auxiliary drain pan where damage to any building components will occur as a result of overflow from the equipment drain pan or stoppage in the condensate drain piping from a cooling or an evaporator coil.

## AIR DISTRIBUTION SYSTEM COMPONENT REQUIREMENTS

Air distribution components installation must conform to the requirements of local authority having jurisdiction or, in the absence of such requirements, to the National Fire Protection Association 90A or 90B.

Do not begin the installation of the system without a system layout and material take-off. If a layout plan is not already available and room terminator requirements determined, then refer to the SpacePak Application Manual, SP9, to complete this information. A description of air distribution system components is shown in Figure 1.1.

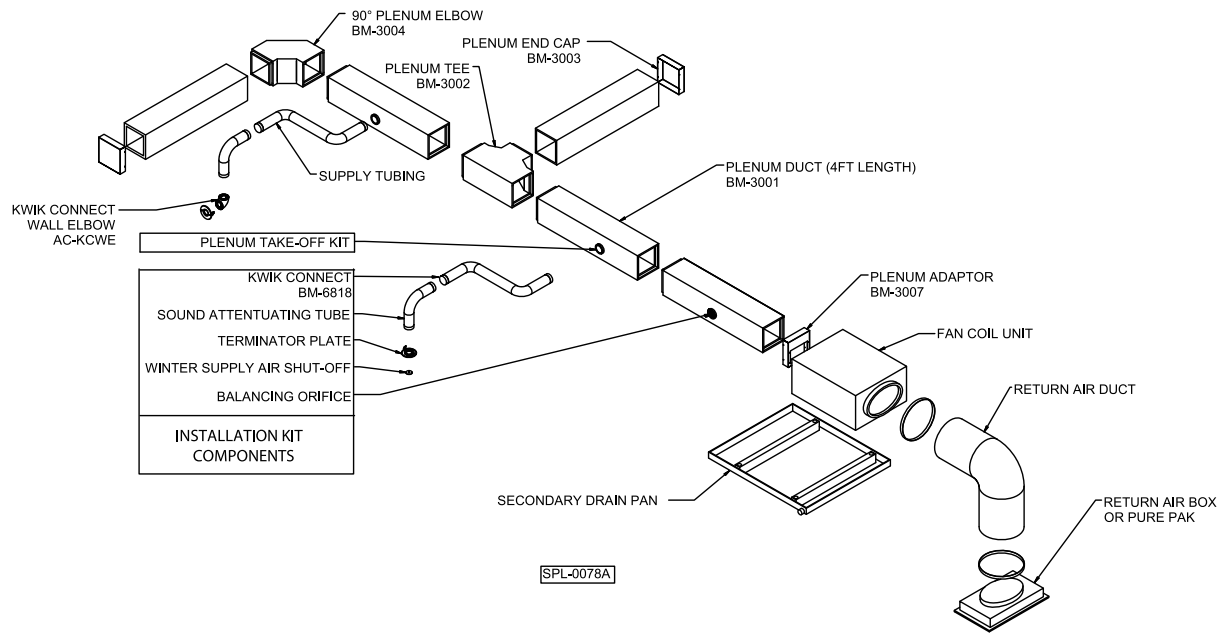

**RETURN AIR BOX (SPC-1D, AC-RBF-3, SPC-3D):** Each includes filter grill with metal frame, permanent filter, and 2 clamp bands. SPC-1D is for WCSP-2430. AC-RBF-3 is for WCSP-3642 and SPC-3D is for WCSP-4860.

**RETURN AIR DUCT (SPC-4,5, & 6):** Flexible, 10 feet long with round shape. SPC-4 (15" dia.) for WCSP-2430. SPC-5 (19" dia.) for WCSP-3642 and SPC-6 (24" dia.) is for WCSP-4860.

**PLENUM ADAPTOR:** 9" round OR 10" X 10" square metal component to attach plenum duct to fan coil unit.

**PLENUM DUCT & COMPONENTS:** May be SmartPak System Duct, 9" round sheet metal or 10" X 10" (O.D.) square, fiberboard duct types as specified by the installing contractor. Above layout is shown as an illustrative assembly reference only.

**R6 SUPPLY TUBING (AC-ST6-100):** Flexible, R6 insulated, 2" I.D. and 3-1/4" O.D. Each section is 100 feet long.

**R8 SUPPLY TUBING (AC-ST8-75):** Flexible, R8 insulated, 2" I.D. and 5-3/8" O.D. Each section is 75 feet long.

**INSTALLATION KITS:** Contains a specified amount of sound attenuating tubes, kwik-connects, terminator plates (incl. spring clips & screws), winter supply air shut-offs and a balancing orifice set to complete installation of room outlets. Supplied in (2) and (5) outlet boxed quantities.

**PLENUM TAKE-OFF KIT:** Contains a specific amount of plenum take-offs, gaskets and fasteners to complete installation of room outlets. Take-offs available for round or square duct as specified by installing contractor. Supplied in (2) and (5) outlet boxed quantities.

**KWIK CONNECT WALL ELBOW (AC-KCWE):** To allow for wall terminations in 2" X 4" stud spaces.

**SECONDARY DRAIN PAN:** Specifically sized for SpacePak horizontal fan coil units. Constructed of durable polyethylene. Fan coil unit sets directly on top and can be installed with threaded rod.

**PLIERS (SPC-72):** To assure full setting of all clips (fasteners) in plenum take-off (not shown).

**PLENUM HOLE CUTTER (SPC-71-10):** To cut 2" hole in fiber board for plenum take-off installation (not shown).

**FIGURE 1.1: AIR DISTRIBUTION SYSTEM COMPONENTS**

## Plenum Duct

The plenum duct can be run in practically any location accessible for the attachment of the supply tubing (see suggested layouts in Figure 1.2). The plenum is normally located in the attic or basement, and it is usually more economical to run the plenum where it will appreciably shorten the lengths of two or more supply runs.

In some two-story split level homes, it may be advantageous to go from one level to another with the plenum duct. Whenever necessary, either between floors or along the ceiling, the small size of the plenum makes it easy to box in.

The fan coil unit is designed to operate with a total external static pressure of 1.5 inches of water column (minimum 1.2 - maximum 1.5). Excessive static pressure is an indication of too few outlets and may cause the coil to freeze and some or all outlets to be noisy.

For systems with a bullhead tee installed as on Unit No. 1 (Figure 1.3), the best results are obtained if not more than 60% of the total number of system outlets are attached to any one branch of the tee. For systems with a branch tee installed as on Unit No. 2 (Figure 1.3), not more than 30% of the total number of system outlets should be attached to the perpendicular branch of the tee.

The larger system capacities (WCSP-3642/4860) are effected more by higher system static pressure than the smaller systems. The four and five ton systems are ideally designed as indicated by the diagram in the lower left corner of figure 1.2. If this layout cannot be followed, it is important to create some pressure drop in the plenum run using elbows and tees. Installation of the plenum tee closer than the minimum indicated in Fig. 1.3 will reduce performance of the system. No supply runs should be installed between unit outlet and this tee. Static readings on system should be taken before tee.

## Supply Tubing

In the case of two-story or split-level applications, supply tubing may run from one story to another. It is small enough to go in stud spaces, but this is often difficult in older homes because of hidden obstructions in stud spaces. It is more common to run the supply tubing from the attic down through second story closets to the first story terminators.

Supply tubing runs in the corners of the second story rooms can be boxed in and are hardly noticeable since overall diameter is only 3-1/4" (Model Number AC-ST6-100).

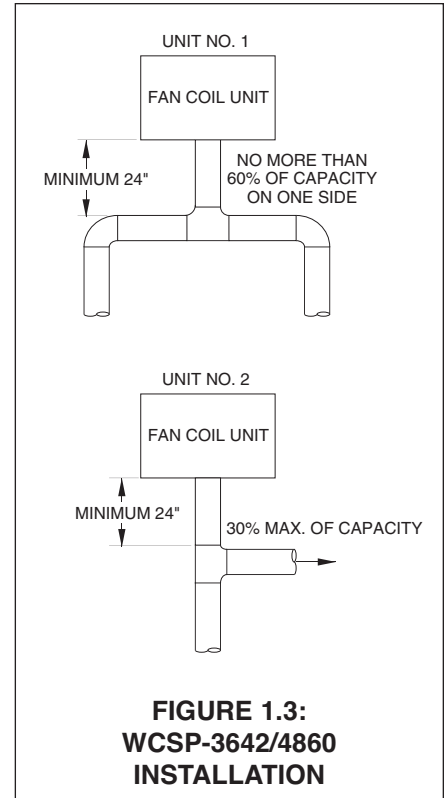
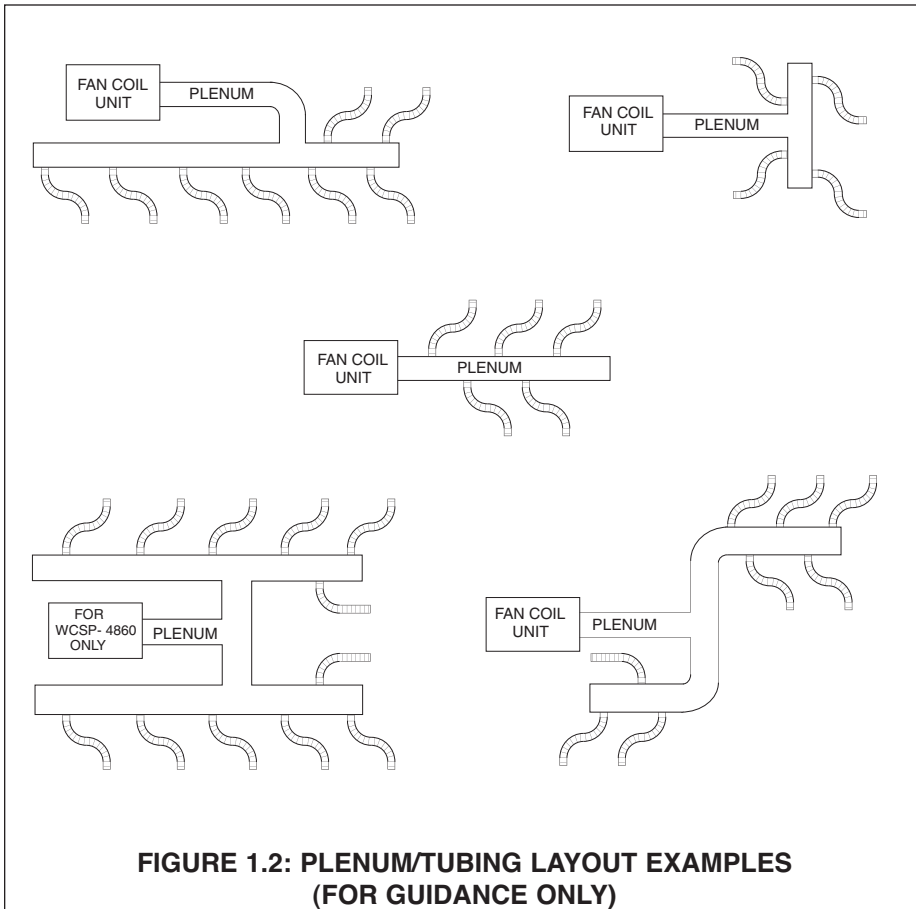

## Room Terminators

Terminators should be located only in the ceiling or floor for vertical discharge. Horizontal discharge is acceptable, but is sometimes more difficult to install. Two excellent spots for horizontal discharge are in the soffit area above kitchen cabinets (see Figure 1.4) and in the top portion of closets (see Figure 1.5).

Terminators should always be out of normal traffic patterns to prevent discharge air from blowing directly on occupants. And they should not be located directly above shelves or large pieces of furniture. Outside wall or corner locations are recommended if the room has more than one outside wall. Locating terminators away from interior doors prevents short cycling of air to the return air box.

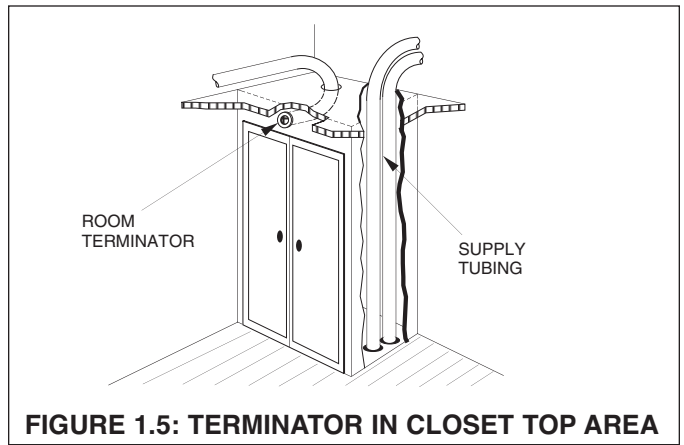
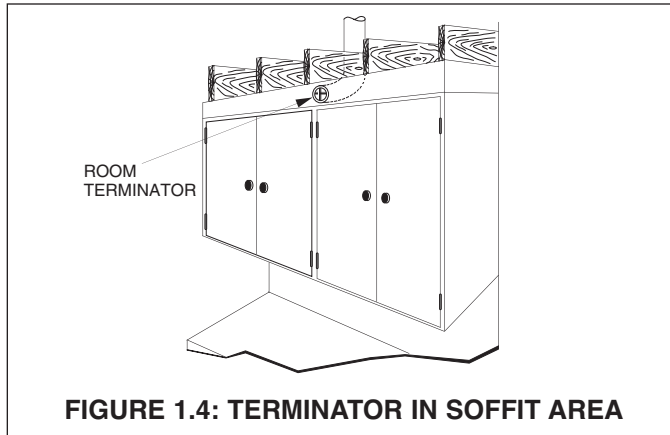

## SHIPMENT OF UNIT

Each fan coil unit is shipped in a single carton. Packed with the unit, there are vibration isolation pads, a condensate trap assembly and a factory installed primary float switch.

# SECTION 2: SYSTEM INSTALLATION

**NOTICE:** Before proceeding with the installation, we recommend reading through this section of the manual for an overall understanding of the air conditioning fan coil unit and air distribution system component installation procedures.

## STEP 1: LOCATING THE UNIT

The fan coil unit may be installed in an unconditioned space (as long as it is protected from the weather) such as an attic, garage or crawlspace...or a conditioned space such as a basement, closet or utility room (see dimensions in Figures 2.2 and 2.3).

The fan coil unit is shipped set-up for horizontal supply air discharge. This can be easily field converted to vertical discharge, as detailed on pg. 9 and Figures 2.9A and 2.9B pg. 10.

When selecting a location, consider the locations (as shown in Figures 2.4, 2.5 and 2.6) of the return air box; routing of the plenum duct, supply tubing, refrigerant lines, condensate drain line; and all recommended clearances (see Figures 2.2).

Model	System capacity (Nom. Tons)	Electrical Characteristics	Connections			
			Bottom Water In	Top Water Out	Cond. Drain (NPT)	Return Inlet (Dia.)
WCSP-2430G	2 - 2-1/2	208/230/1/60	7/8"	7/8"	3/4"	15"
WCSP-3642G	3 - 3-1/2	208/230/1/60	7/8"	7/8"	3/4"	19"
WCSP-4860G	4 & 5	208/230/1/60	7/8"	7/8"	3/4"	24"

Model	System capacity (Nom. Tons)	Blower					Coil		Ship. Wt. (lbs)
		Std. CFM @ 1.5" W.C.	Wheel Dia. and Width	Motor HP	Motor Type	F.L. Amps	No. of Rows Deep	Flow Rate per Ton (GPM)	
WCSP-2430G	2 - 2-1/2	550	9" x 5"	1/3	PSC	1.8	6	2.4	120
WCSP-3642G	3 - 3-1/2	850	9" x 5"	1/2	PSC	2.8	6	2.4	144
WCSP-4860G	4 & 5	1150	9" x 6-3/8"	1	PSC	3.6	6	2.4	171

**FIGURE 2.1: MODEL WCSP-D SPECIFICATIONS**

MODEL	A	B	C	D
WCSP-2430G	24-1/8"	12"	18-1/2"	10-1/4"
WCSP-3642G	33-1/8"	16-1/2"	25-1/2"	9-3/4"
WCSP-4860G	43-1/8"	21-1/2"	33-7/8"	9-7/8"

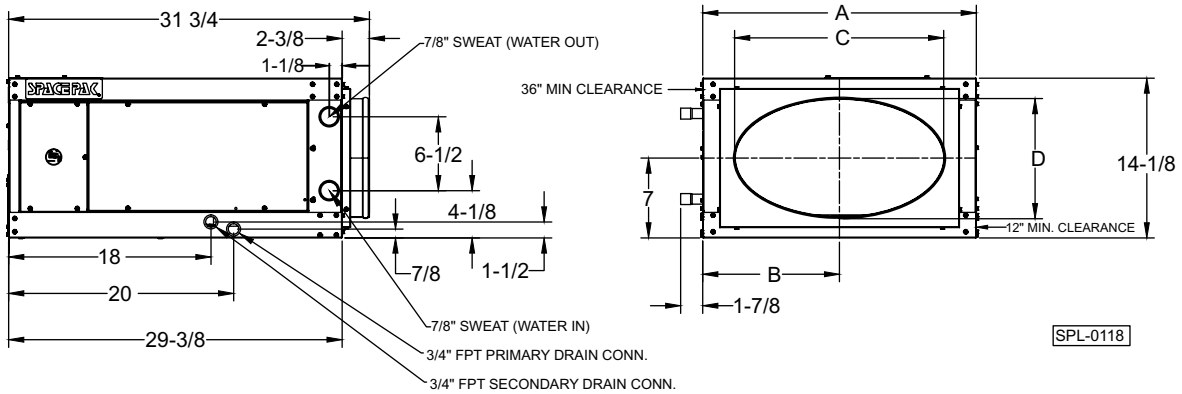

**FIGURE 2.2: UNIT DIMENSIONS AND CLEARANCES (Inches)**

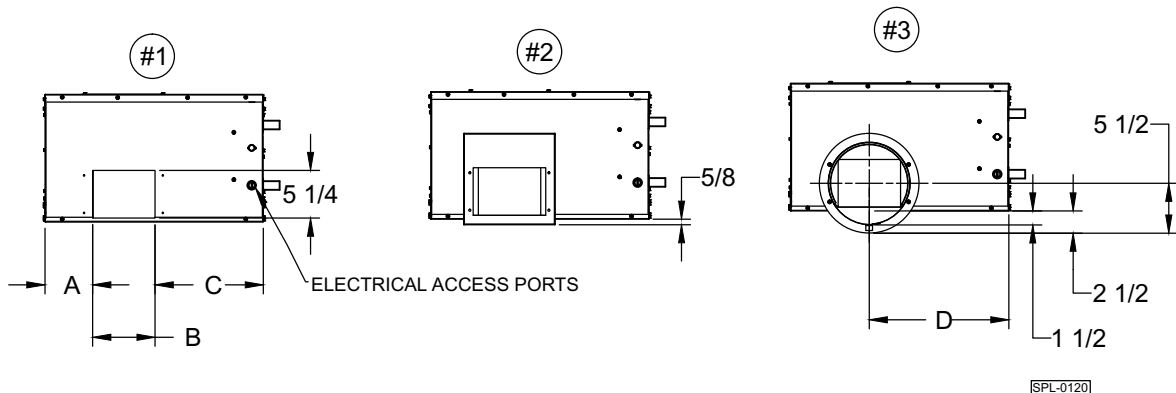

MODEL	A	B	C	D
WCSP-2430G	5-1/4	6-1/2	12-1/2	15-3/4
WCSP-3642G	7-1/2	6-1/2	19	22-1/4
WCSP-4860G	17-7/8	7-5/8	17-5/8	21-7/16

**FIGURE 2.3: CONNECTION LOCATIONS AND ASSEMBLED PLENUM ADAPTER DIMENSIONS**

**WCSP-2430 @ 550 cfm Cooling Capacity**

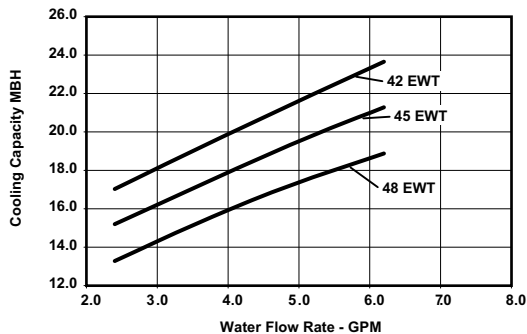

**WCSP-2430 @ 550 cfm Heating Capacity**

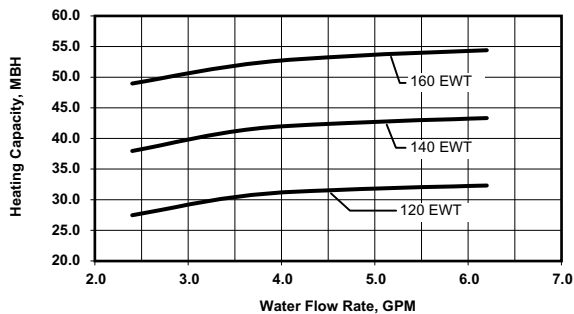

**WCSP-3642 @ 850 cfm Cooling Capacity**

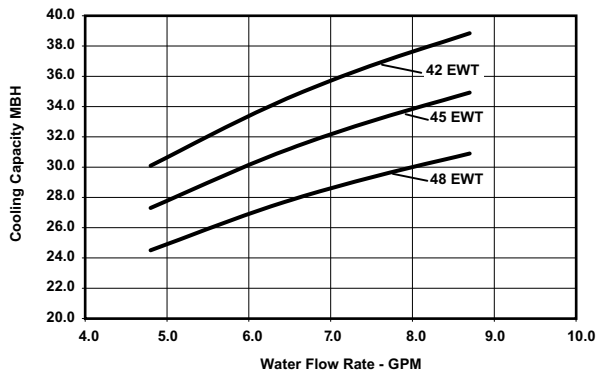

**WCSP-3642 @ 850 cfm Heating Capacity**

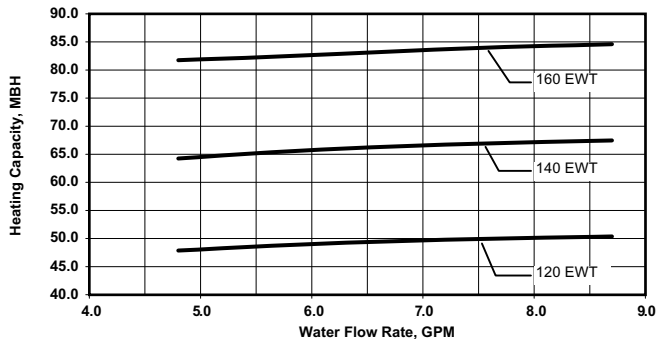

**WCSP-4860 @ 1150 cfm Cooling Capacity**

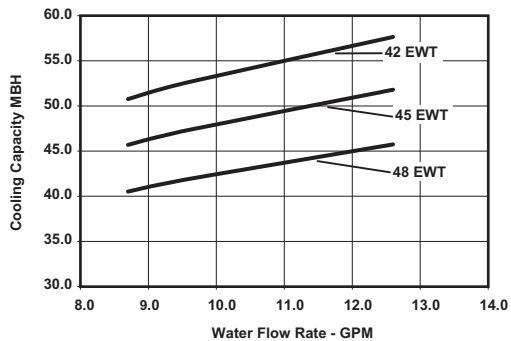

**WCSP-4860 @ 1150 cfm Heating Capacity**

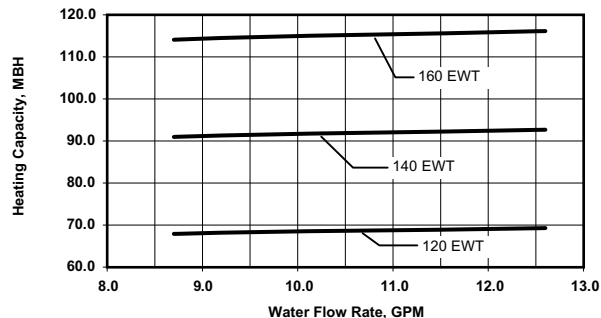

**Hydronic Coil Pressure Drop Characteristics**

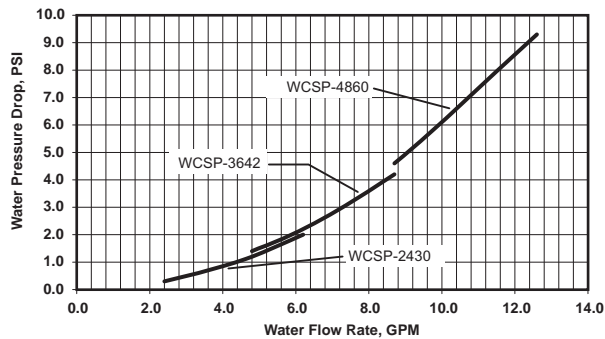

**Hydronic Coil Pressure Drop Characteristics**

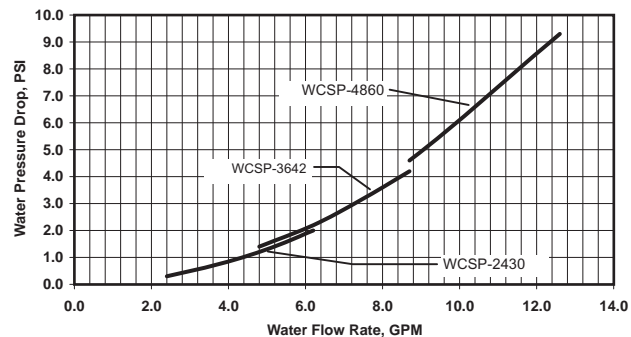

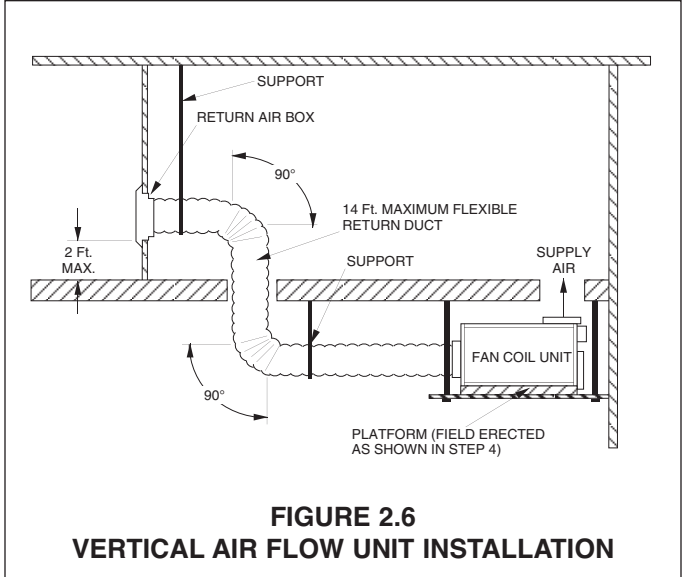
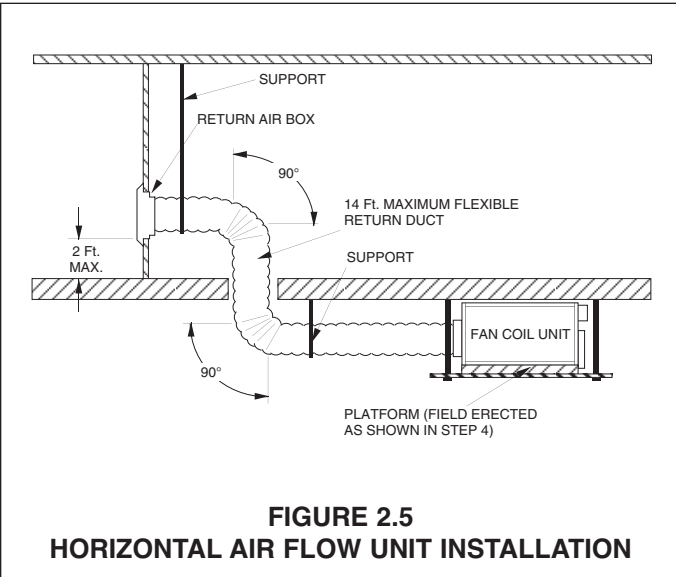
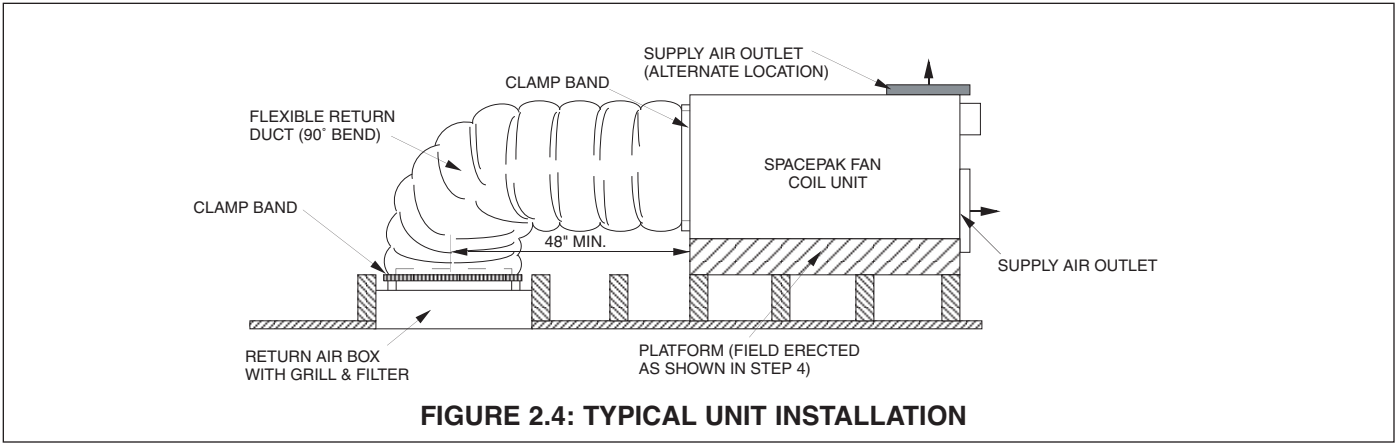

**STEP 2: CUTTING RETURN AIR OPENING**

Select exact location for return air box. Avoid installing box in dining room, living room, kitchen, etc., unless return air duct can be installed with at least two 90° bends (accomplished by splicing two return air ducts together.)

For attic installations to raise fan coil unit up through opening, cut return air opening 14-1/2" wide by 27" long for the WCSP-2430D, 14-1/2" wide by 31-1/2" long for the WCSP-3642D\* and 14-1/2" wide by 36-1/2" long for the WCSP-4860D. These openings will accommodate the return air box with sufficient frame lip to cover the opening (see Figure 2.7).

**NOTICE: The electrical box must be removed from the WCSP-3642 unit to fit through hole cut out.**

**Refer to the "Installation Tip" supplied with the return air box.**

If ceiling joists are on 16" centers, the 14-1/2" width of the return air box should fit between successive joists. Where joists run in the opposite direction, or to properly center the return, it may be necessary to cut joists and install headers.

For all wall return applications, cut the return air opening to accommodate the return air box (measure box itself). Remember, location of opening must allow for a 90° bend in the return air duct.

Check the opening for proper fit of the return air box. Do not install the return air box until the installation of the entire SpacePak system is completed, if you want to fit materials up through this hole.

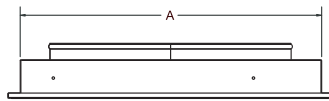

Measure return air box dimension "A" to determine length of opening.  
Height = 14-5/16"

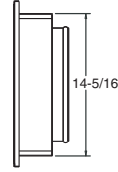
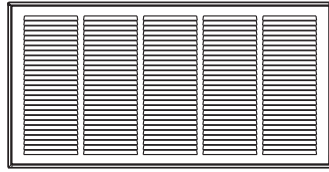

DWG0045

FIGURE 2.7: RETURN AIR BOX FRAME DIMENSIONS

### STEP 3: ATTACHING SUPPLY AIR PLENUM ADAPTOR

**NOTICE:** If the unit is to be located in the attic and installed through the ceiling joists, attach the supply air plenum adaptor in the attic.

#### A. HORIZONTAL DISCHARGE:

Refer to Figure 2.8 and duct installation instructions supplied with fan coil unit.

#### B. TO CONVERT TO VERTICAL DISCHARGE:

Refer to Figure 2.9A & 2.9B.

Tools required: 1/4", 5/16", 3/8", 7/16" box wrenches and nut drivers, 5/32" Allen wrench, utility knife & Malco S-3 offset hand seamer (3" duct-bill pliers).

Field supplied: latex caulk, UL classified duct liner adhesive (or equivalent).

**NOTICE:** An Electric Heat Module cannot be installed after unit has been field converted to vertical supply air discharge (due to resulting blower housing obstruction).

Refer to Figure 2.9A for Steps 2 to 8a.

1. Place unit horizontally on a flat raised surface.
2. Remove all side access panels, return air panel and cover plate from top panel.
3. Remove top panel by removing top/center screw from electric control box and panel screws.
4. Remove (4) screws securing front panel flange to blower housing.

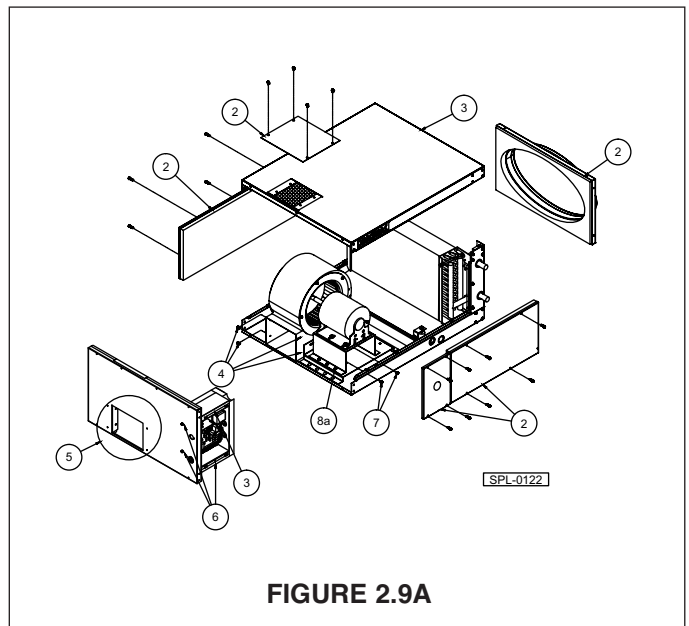
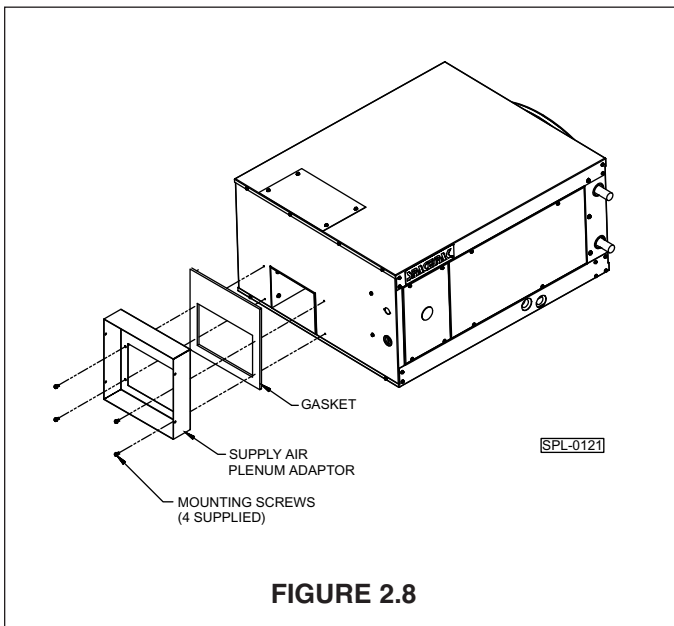

5. Remove sealant around discharge opening.
6. Remove (3) remaining screws from electrical control box. Set box aside.
7. Remove (2) screws attaching blower housing to motor support channel flange.
- 8a. Remove (6) screws attaching motor mounting base to motor support channel.

**Refer to Figure 2.9B for Steps 8b to 18.**

- 8b. Shift motor mounting base (and blower housing) back toward coil to second set of mounting lugs on motor support channel. Rotate blower housing up 90°. Reattach base with screws.
9. Cut insulation from discharge air location on top panel (opening dimensions shown in Figure 2.3). Insert cut piece into horizontal supply panel air opening. Apply adhesive per manufacturer's instructions. Attach cover plate to front of unit.
10. Bend both flanges 90° into cabinet using 3" duct-bill pliers. Pliers should engage full jaw depth (1-1/4") and be centered on flange.
11. Insert blower housing into top panel. Reattach panel to unit.
12. Align hole in blower housing with upper slots in motor support channel flange. Attach housing to flange with (1) previously removed screw.
13. Align (4) holes in top panel flanges with holes in blower housing. Attach with removed screws.
14. Assure blower wheel is centered in inlet and discharge of blower housing. If required, adjust by loosening (4) bolts securing motor. Shift motor and refasten. For blower wheel adjustments, loosen set screw (not shown), shift wheel and refasten.
15. Apply latex caulk to seal between blower housing and top panel.
16. Reinstall electrical control box.
17. Place supply air plenum adaptor over discharge opening. Align holes in plenum adaptor, gasket and top panel. Secure with screws provided with adaptor.

**NOTICE: Check that all inside cabinet surfaces are covered with insulation, add insulation if required. An uninsulated panel will "sweat" and condensate will form on the cabinet.**

18. Replace all panels and screws.

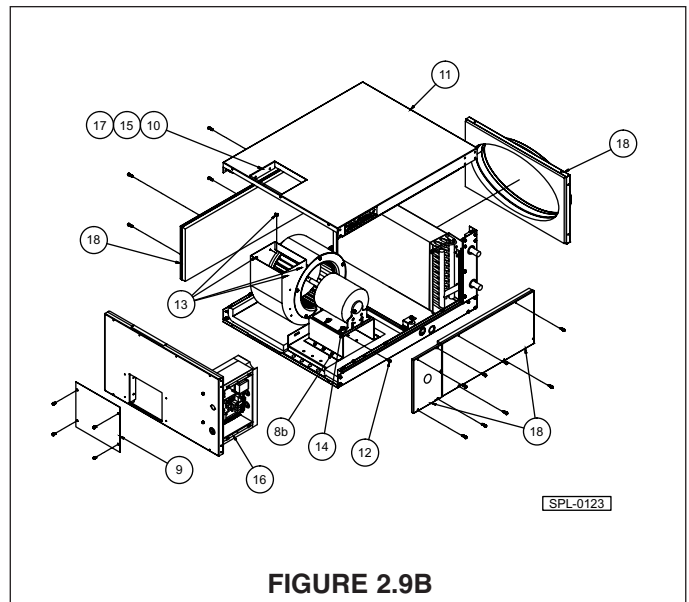

**FIGURE 2.9B**

## STEP 4: SETTING THE UNIT

Construct a platform for the fan coil unit, as shown in Figure 2.10. The platform can be constructed of 2x4 (minimum), 2x6, 2x8 and 2x10 lumber, as necessary to achieve sufficient height so that proper condensate drain line pitch of 1/4" per foot can be maintained. Figure 2.11 shows the approximate normal allowable run of condensate piping as a function of the framing lumber used for platform construction. The platform covering should be 1/2" plywood minimum.

Attach vibration isolation pads (supplied inside fan coil unit) to platform covering as shown in Fig. 2.10.

Secure the platform to the joist or floor, depending on location selected for the fan coil unit. Make sure platform is level.

For locations where the fan coil unit will be suspended, suspend platform from overhead by 1/4" threaded rods.

**NOTICE: Leave room on sides for servicing.**

For installations with a return air box and return air duct, set fan coil unit on the platform with the elliptical opening facing in the direction of the return air opening. The supply air plenum adaptor should overhang the platform. **DO NOT** let the adaptor support the weight of the unit.

Do not secure the unit to the platform, as the weight of the unit will hold it in position.

Connect refrigerant lines from outdoor condensing unit to the fan coil unit. The refrigerant lines and unit should be installed in accordance with the manufacturer's instructions.

LUMBER SIZE	2 X 4	2 X 6	2 X 8	2 X 10
MAXIMUM HORIZONTAL	8'	16'	24'	32'

**FIGURE 2.11: CONDENSATE PIPING RUNS**

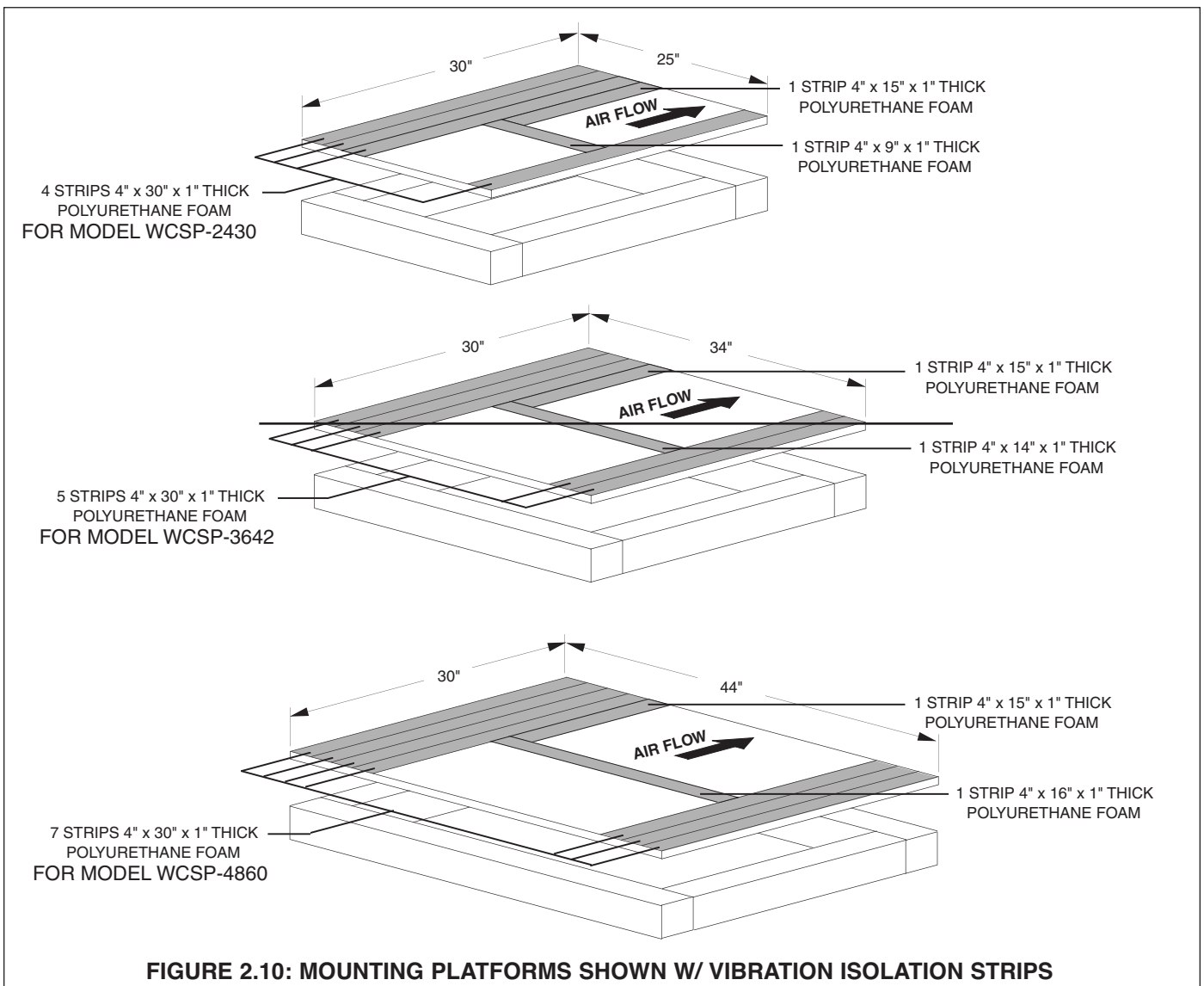

**FIGURE 2.10: MOUNTING PLATFORMS SHOWN W/ VIBRATION ISOLATION STRIPS**

## STEP 5: CONNECTING WATER LINES

Connect water lines from outdoor chiller unit to the fan coil unit in accordance with the chiller manufacturer's recommendations.

## STEP 6: INSTALLING THE CONDENSATE TRAP & LINE

**NOTICE:** It is a requirement of the International Mechanical Code (307.2.3) to install a secondary drain or an auxiliary drain pan where damage to any building components will occur as a result of overflow from the equipment drain pan or stoppage in the condensate drain piping from a cooling or an evaporator coil. Follow local code requirements

Refer to Fig. 2.2 for primary and secondary condensate drain locations. Components for the PVC condensate trap are provided in a separate bag with fan coil unit (see Fig. 2.12) and should be cemented together with PVC pipe cement.

**CAUTION** Do not use substitute trap. Do not cut off or alter trap components.

Screw male adapter (see Fig. 2.12) into unit's primary condensate drain connection. Assemble and cement remaining components together. Then cement assembly to male adapter. The 45° elbow provides an offset from beneath unit suction line for access to clean-out plug.

Run a condensate line from the trap to a suitable drain that's in accordance with local codes. Make sure the line is pitched 1/4" per foot.

**NOTICE:** The secondary drain connection requires field supplied components to complete installation. Follow local code requirements.

**NOTICE:** Never connect condensate line to a closed drain system.

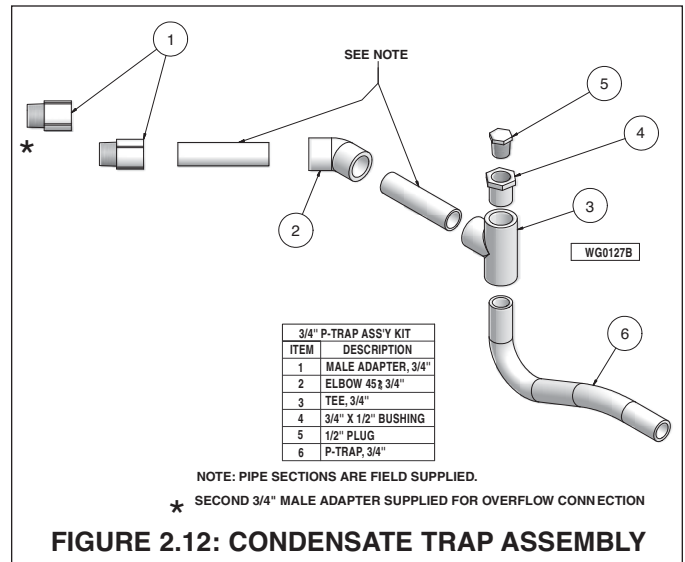

FIGURE 2.12: CONDENSATE TRAP ASSEMBLY

## STEP 7: WIRING THE UNIT

**WARNING** Turn off electrical power supply before servicing. Contact with live electric components can cause shock or death.

All electrical and control wiring must be installed in accordance with the codes listed in Section 1 of this manual. Wiring diagram is provided in Figure 2.13. A separate 208-230/60/1 power supply is recommended for the unit. Use standard 15-amp fuse and 16-gauge wire from power supply to unit.

Connect power supply to Terminals L1 and L2 on the high voltage terminal block. Connect a ground wire to the equipment ground terminal located next to the high voltage terminal block.

The low voltage transformer in the unit has a 208 volt tap in the primary winding (color coded RED). If unit is to be operated with 208 volt electrical service, remove the 230 volt ORANGE lead from the L2 terminal and connect the 208 volt RED lead to the L2 terminal. Be sure to insulate the end of the unused ORANGE lead.

Locate the room thermostat on a wall near the return air box, between 40" to 48" from the floor. Connect the low-voltage thermostat wiring from the room thermostat to the control board in the unit.

Connect low voltage from air handler to condensing unit as shown in figure 2.13.

Set DIP switches according to application. See page 14, SpacePak G Series Control DIP switch settings.



## STEP 8: INSTALLING AIR DISTRIBUTION COMPONENTS

All plenum duct and supply tubing runs as well as room terminator locations must be in accordance with air distribution system requirements listed in Section 1 of this manual. Where taping of joints is required, UL181 approved tape is required.

### Plenum Duct Installation

All tees, elbows and branch runs must be a minimum of 24" from the fan coil unit or any other tee, elbow or branch run. Keep all tees and elbows to a minimum to keep system pressure drop on larger layouts to a minimum.

**NOTICE:** Refer to duct installation instructions supplied with fan coil unit or follow manufacturers instructions supplied with other duct system types.

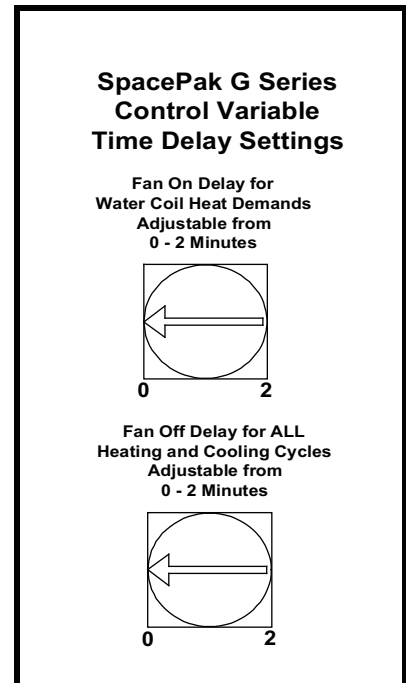
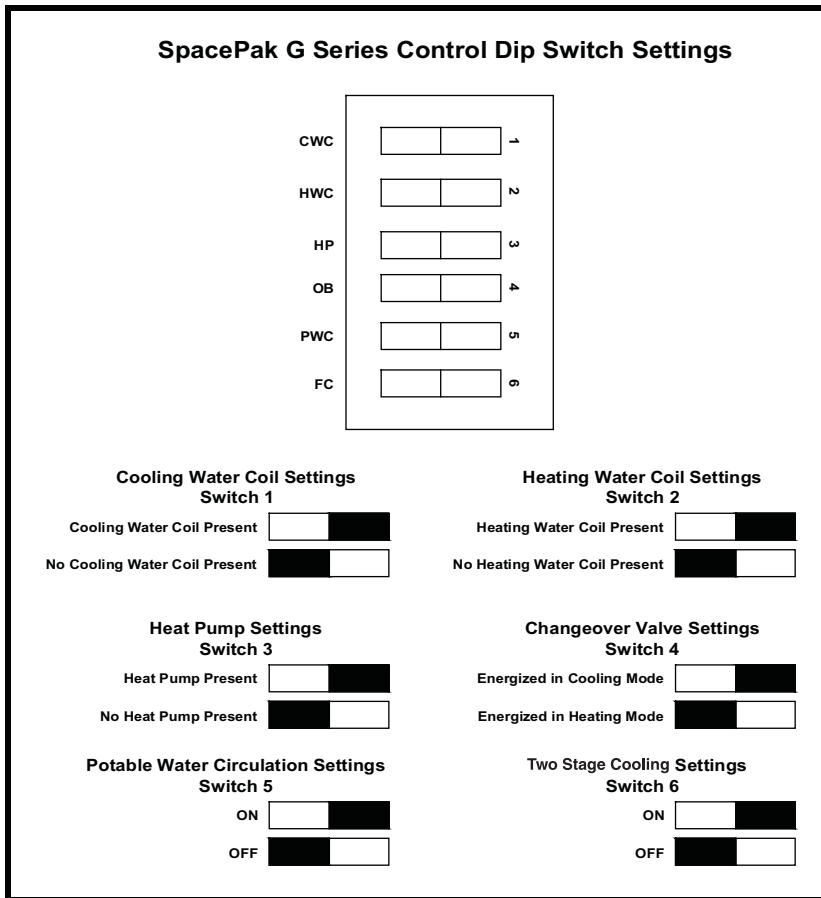

## SpacePak G Series Control Indicator LEDs

### Power Indicator

The Power indicator will blink to indicate that the control is operational.

### Fan Prove Indicator

The Fan Prove indicator will illuminate when there is power to the fan and the optional damper is in the open position.

Note: The Fan Prove Terminal will also energize with 24VAC when the above conditions are met.

### Fault Indicator

Fault Flash Codes:

Float Switch	1 Flash
Anti-Frost Switch	2 Flashes
Fan Prove Fault	3 Flashes

Note: All Flash Codes are latched until power is cycled, even if the fault is cleared. The Float Switch requires power to be cycled to resume operation.

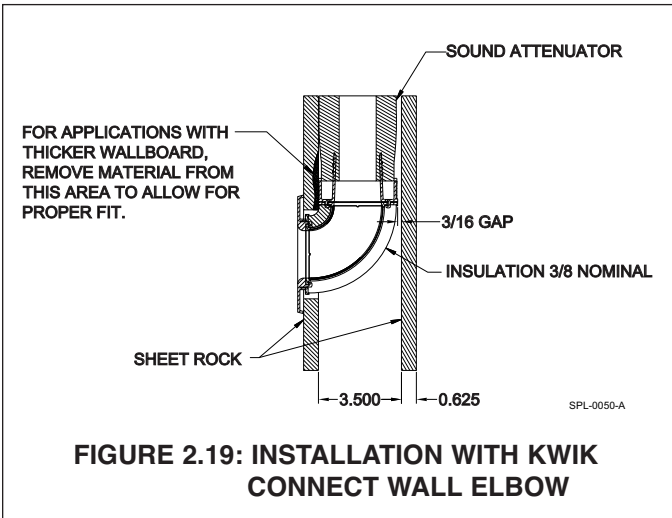
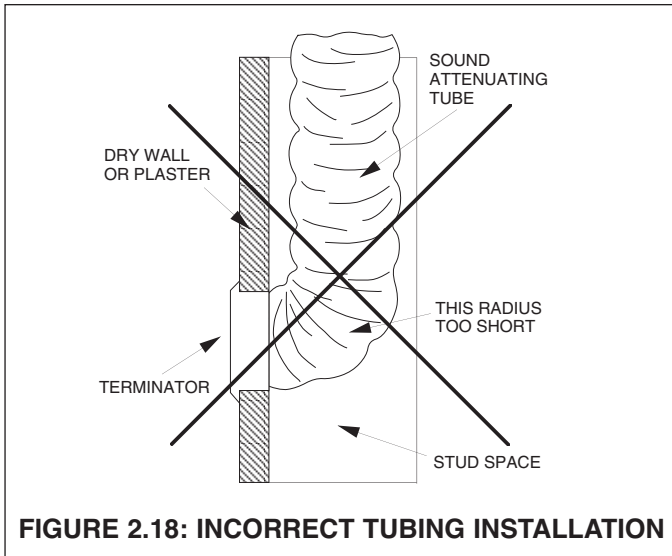

### Room Terminator & Sound Attenuating Tubing Installation

Room terminators and pre-assembled sound attenuating tubes are provided in the Installation Kits.

**NOTICE:** Do not install terminators in a wall in which a sharp bend in the sound attenuating tube is required (see Figure 2.18). The result would be unacceptable noise.

**OPTION:** Using a SpacePak Kwik Connect Wall Elbow (Model Number: AC-KCWE) addresses this condition (see Figure 2.19).

In marking location for room terminator (see Figure 2.20), the center of the terminator should be 5" from the wall or, when installed in the corner of a room 5" from both walls.

After marking location, drill a 1/8" diameter hole for outlet. Verify there is at least a 2" clearance all around the 1/8" hole to receive tubing and connector. Adjust direction of hole as needed, to gain this 2" clearance. After all clearances have been checked, take a 4" diameter rotary-type hole saw and cut a hole, using the 1/8" diameter hole as a pilot.

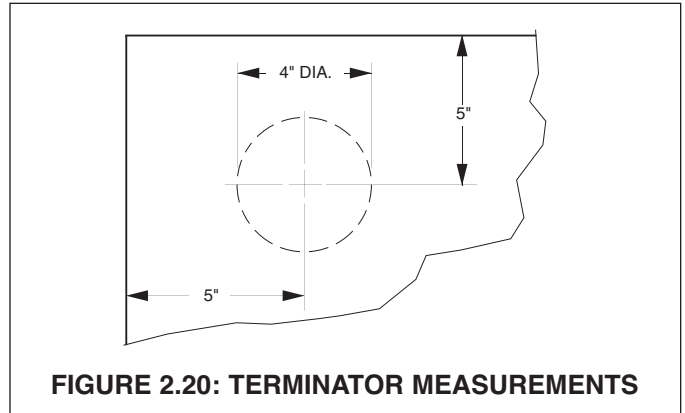

Assemble spring clips to terminator plate with screws provided in installation kit. Tighten clips until they are close to the thickness of the material they are being mounted to.

Assemble the room terminator to the sound attenuating tubing by simply fitting the two pieces together and twisting until tight (see Figure 2.21). If the terminator is to be used in a floor location, then field fabricate a small screen (1-1/2" square; 1/4 x 1/4 20-gauge galvanized wire screen) and place screen over opening on the back of the terminator prior to twisting on the kwik-connect (on the sound attenuating tube).

**NOTICE:** Do not shorten sound attenuating tube length. The result would be unacceptable noise.

Push the free end of the sound attenuating tube through the 4" hole until the two toggle springs on the room terminator snap into place.

Center the two spring clips on a line parallel to the direction of the tubing routing from the room terminator (see Figure 2.21). This is important since the weight of the tubing will have a tendency to cause a part of the terminator to pull away from the ceiling if the clips and tubing do not run parallel.

Then tighten the screws (attached to the terminator) until the terminator is snug against the ceiling or floor. **Do not overtighten.** For installations with floors or ceilings which are thicker than normal, longer toggle screws or special mounting plates may be required.

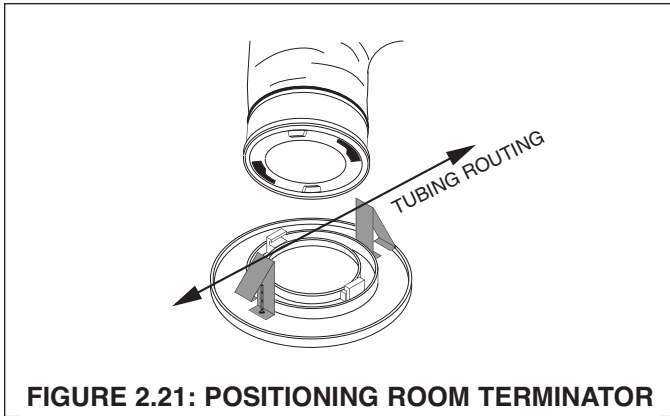
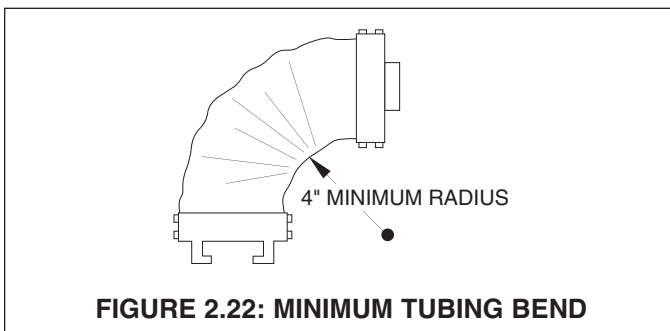

**FIGURE 2.21: POSITIONING ROOM TERMINATOR**

### Supply Tubing Installation

Kwik-connects and balancing orifices are provided in the Installation Kits. Plenum take-offs, gaskets and fasteners are supplied in the separate plenum take-off kits.

Avoid sharp bends in the supply tubing (as well as the sound attenuating tube). The minimum radius bend is 4" (see Figure 2.22); however, wherever possible, hold to a larger radius.



**FIGURE 2.22: MINIMUM TUBING BEND**

At the plenum, all supply tubing connections must be a minimum of 18" from any plenum tee, plenum elbow or the fan coil unit.

Individual supply tubing runs **must be a minimum of 6-feet**, even if the distance between the sound attenuating tubing and plenum is less than 6 feet.

Supply tubing comes in 100-foot sections (R8 tubing comes in 50-foot sections and R6 tubing comes in 75-foot sections) and may be cut to length with a knife or fine tooth hacksaw.

For each supply tubing run, estimate and cut the length of tubing that will be needed between the plenum and sound attenuating tube. At the open end of the supply tubing a kwik-connect will be installed (see Figure 2.22). First, push back the cover and the insulation exposing approximately 4" of the inner core. Fold in any tails or frays that may be present after cutting the supply tubing. Second, hand compress the corrugations until they are densely compacted 1-1/2" to 2" from the open end of the supply tube. Third, thread kwik-connect into the inner core until snug. Fourth, pull the insulation and cover forward and tuck it into the deep groove on the back side of the kwik-connect. Fifth, wrap the connection securely with UL181 approved tape..

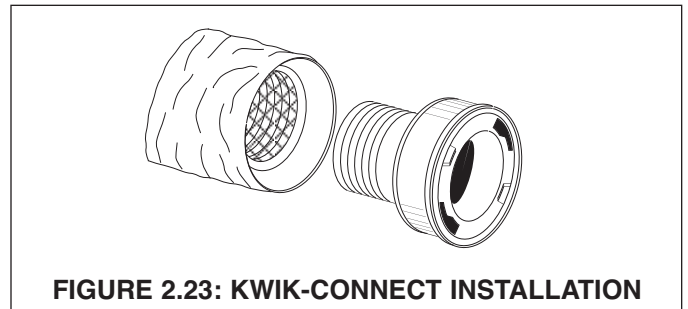

**FIGURE 2.23: KWIK-CONNECT INSTALLATION**

When finished, simply twist together (see Figure 2.24) the kwik-connect on the sound attenuating tube, and wrap the connection securely with tape.

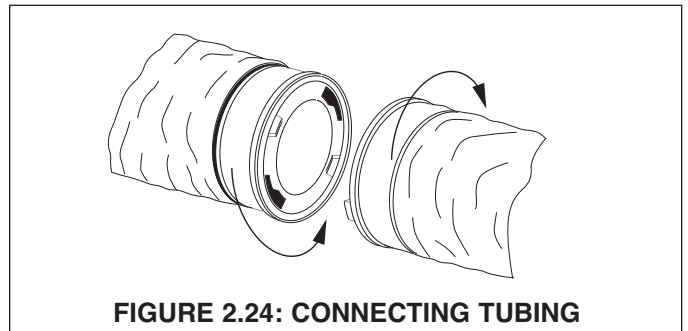
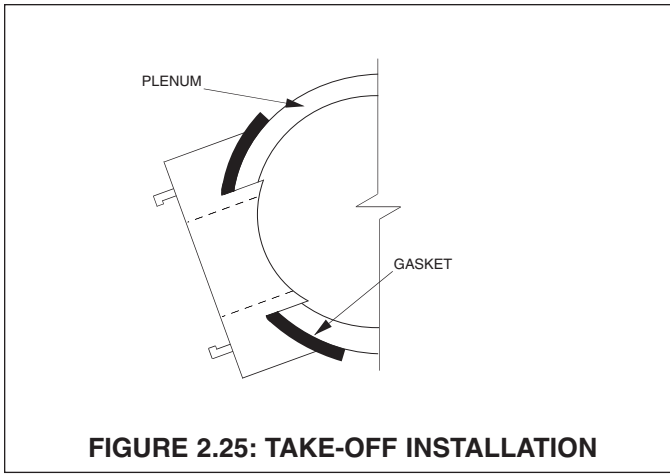

**FIGURE 2.24: CONNECTING TUBING**

After attaching the supply tubing to the sound attenuating tube, bring the open end of the tubing to the plenum.

To cut a hole in the plenum, refer to duct installation instructions supplied with fan coil unit. Sheet metal duct requires a 2-1/16" hole.

Remove the hole cut-out from the plenum. Make sure there is no "flap" left inside plenum that could block hole during operation.



Place the plenum take-off gasket on the back side of the plenum take-off and insert the assembly into the hole in the plenum (see Figure 2.25).

**NOTICE: Gasket must be installed to seal plenum take-off to prevent air leakage.**

Orient the plenum take-off to match the curvature of the plenum duct. Hand insert the four plenum take off fasteners one at a time such that each clip reaches the interior of the duct. Using the SpacePak pliers, snap the fasteners into place until they lock in place (see Figure 2.26).

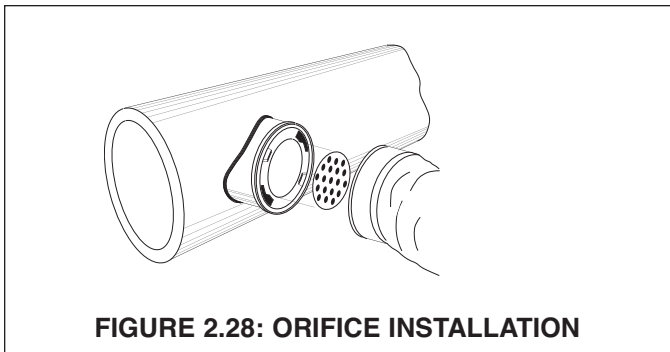
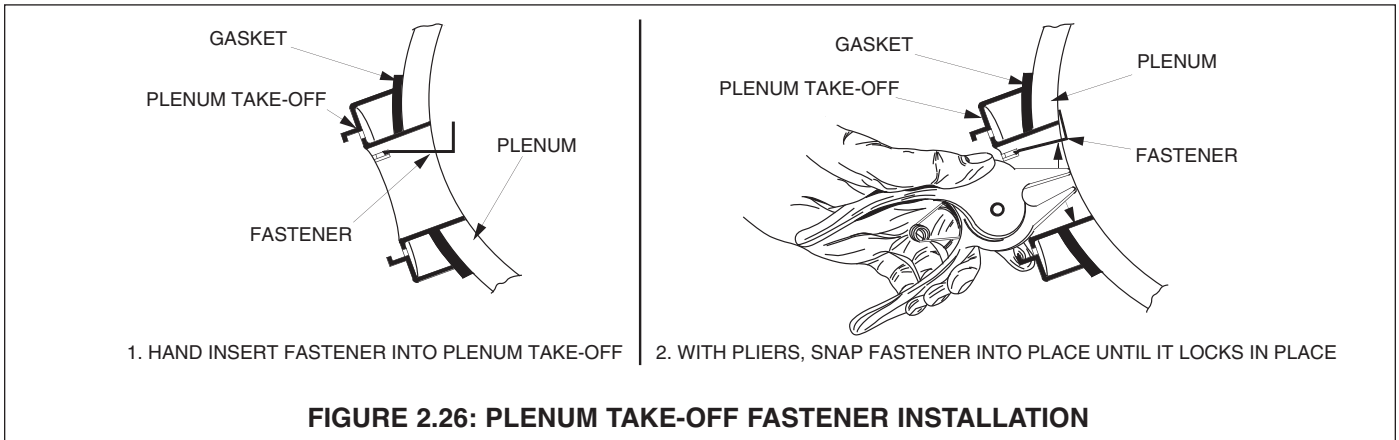

**NOTICE: All four fasteners must be installed to assure air tight fitting between plenum take-off and plenum.**

In accordance with your calculations as to requirements for balancing orifices, mount the orifice in the outlet of the plenum take-off (see Figure 2.28), prior to attaching the supply tubing.

Next, install a kwik-connect in the open end of the supply tubing, using the same procedures as before, and twist together kwik-connects on supply tubing and plenum take-off. Wrap connection securely with tape.

## Return Air Box & Duct Installation

Remove the return air grill from the return air box and remove the air filter from the return air grill.

Insert the return box from below for ceiling installation (or from the front for wall installations) and fasten with four screws through holes provided on the long side of the box. (see Figure 2.28).

Then, insert return air grill into box (see Figure 2.28) and fasten with the four screws provided through the holes on both sides. Open return air grill (turn the  $\frac{1}{4}$  turn latches) and insert filter. Close the return air grill. Slide a clamp band (provided with return air box) over one end of the return air duct. Place that end over the elliptical flange on the fan coil unit (see Figure 2.29). Move the clamp over the flange and tighten so the clamp holds the return air duct securely to the flange.

Follow the same procedures to attach the return air duct to the return air box (see Figure 2.29).

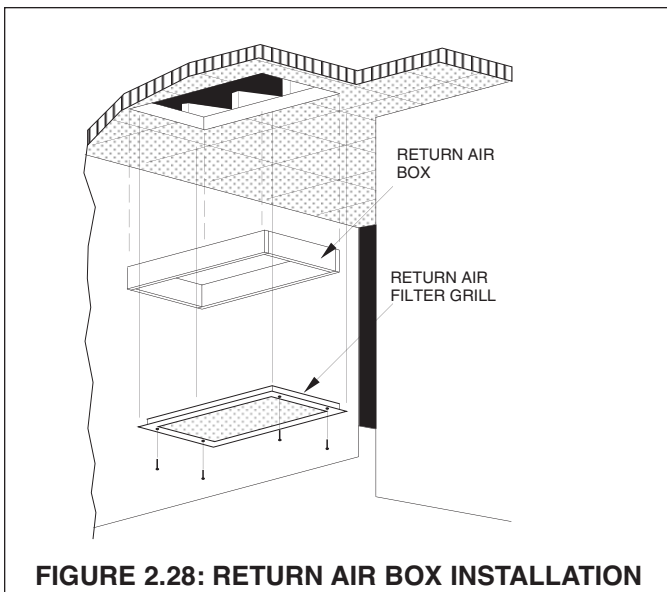

FIGURE 2.28: RETURN AIR BOX INSTALLATION

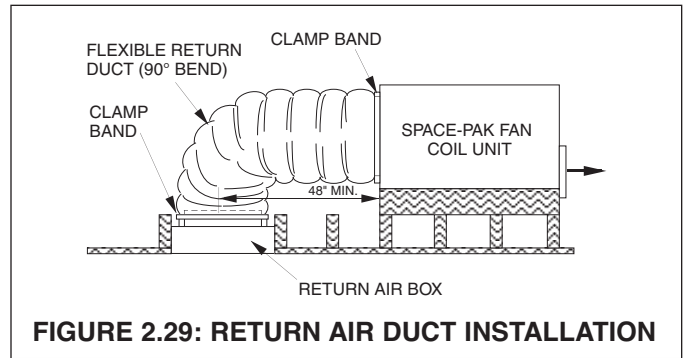

FIGURE 2.29: RETURN AIR DUCT INSTALLATION

## Winter Supply Shut-Off Installation

Simply insert winter supply shut-offs into the room terminator openings (see Figure 2.30). Wrap the return air filter in a plastic bag and reinstall it to block the return air opening. Winter supply shut-offs prevent moisture from collecting in ductwork during winter months. Be sure to remove the plastic bag and all winter supply shut-offs before operating the system.

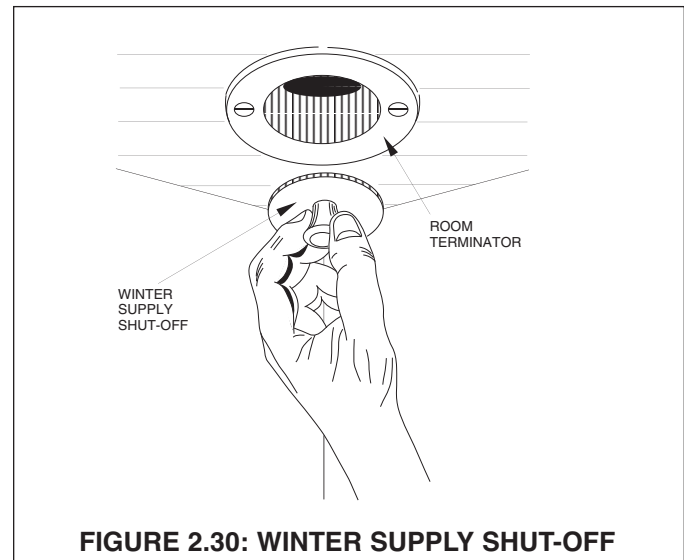

FIGURE 2.30: WINTER SUPPLY SHUT-OFF

# SECTION 3: START-UP & OPERATION

## SEQUENCE OF OPERATION

When power is turned on and thermostat fan switch is set to ON and the cooling indicator is set to OFF, the indoor fan motor is energized through the normally open contact FR-1 of the FR fan relay in about 30 seconds. The outdoor unit is off.

When power is turned on and thermostat fan switch is set to ON or AUTO and the cooling indicator to COOL the indoor and outdoor units will start through the normally open contacts FR-1 and FR-2 of the FR fan relay.

The fan coil unit is equipped with a primary float switch, the outdoor unit will automatically shut down if the drain pan is full of water (condensate) and not draining. The fan coil unit will continue to operate. When the water level in the drain pan drops, the system will continue normal operation.

## PRIOR TO START-UP

1. Check all electrical connections for tightness.
2. Check air filter has been installed in return air box or filter box.
3. Remove all winter supply shut-offs and store them in a safe place.

## SYSTEM START-UP & ADJUSTMENTS

1. Place thermostat fan switch in ON position and cooling indicator in OFF position. In about 30 seconds, indoor unit blower will start.
2. Check blower operation for excess noise or vibration.
3. Check entire distribution system for leakage and apply additional tape where necessary.
4. Check that system static pressure is within acceptable limits (minimum 1.2" W.C. - maximum 1.5" W.C.). Static readings must be taken in the plenum a minimum of 18" (or after the tee on WCSP-4860G systems) from the fan coil unit, plenum tees or elbows but before any supply run.

- a. If greater than 1.5" W.C. add additional supply runs.
- b. If less than 1.2" W.C. check the return air filter is clean and return duct is not collapsed or kinked.

- c. Check supply air plenum for leaks.
- d. If more supply runs than recommended are used, check that balancing orifices are in place.
5. Check that blower motor amp draw compares with fan coil unit rating plate. Amp draw shown on plate is the FLA of motor (not the actual running amps) and will vary with the pressure and voltage.
6. Place the thermostat cooling indicator in COOL position, which will start the outdoor unit. Let the system run at least 30 minutes to stabilize operating conditions.
7. For outdoor unit start-up, follow manufacturer's instructions.
8. Check that temperature drop across coil in the indoor unit is between 20°F to 28°F.
9. Check the chiller or boiler for proper operation according to the manufacturer's instructions.

## COMMON START-UP CONDITIONS

	CONDITION	VERIFICATION	SOLUTION
A.	Lack of cooling	1. Chilled water loop temperature	1. Adjust water temperature in chilled water loop
B.	Lack of heating	1. Hot water loop temperature	1. Adjust water temperature in hot water loop
C.	Blows cold air on initial start-up	1. Fan is controlled by a thermostat 2. Fan is controlled by an aquastat	1. Install aquastat 2. Adjust setting to allow water loop to reach proper temperature
D.	Condensate does not drain properly	1. Unit is not level 2. Unit is not trapped 3. Drain line is blocked	1. Make sure unit is level 2. Install trap supplied with unit 3. Clear blockage
E.	Unit sweats inside	1. Insulated panels not secured cabinet	1. Secure and seal all insulated panels to prevent air infiltration

**FACTORS AFFECTING THE BALANCE OF THE SYSTEM**

A. Room Terminators (Outlets): Based on the equipment selected, determine the recommended number of fully open outlets from Figure 3.1.

**FIGURE 3.1**

NOMINAL TONNAGE	MINIMUM RECOMMENDED NUMBER OF FULLY OPEN OUTLETS		
	MODEL	A	B
2	WCSP-2430G	12	14
2 1/2	WCSP-2430G	15	18
3	WCSP-3642G	18	21
3 1/2	WCSP-3642G	21	25
4	WCSP-4860G	26	28
5	WCSP-4860G	30	35

1. The minimum or recommended number of outlets means fully open outlets. Any outlet having an orifice would be only a percentage of an outlet.

2. For systems with average supply tubing lengths of 15 feet or less, use column A. For systems with supply tubing lengths greater than 15 feet, use column B.

**NOTICE: The number of outlets and average length of the supply tubing has a significant effect on the overall system performance. It is highly recommended that the adjustment factors outlined in the SpacePak Application Manual are accounted for prior to any installation.**

B. Orifice Combinations: Should orifices be required to balance the system (installed at plenum take-off), refer to the combinations listed in Figure 3.2.

**FIGURE 3.2**

DESIRED NUMBER OF TERMINALS *	TERMINAL - ORIFICE COMBINATION
.5	(1) .5
.65	(1) .35
.85	(1) .15
1.00	(1)
1.15	(1) .5 + (1) .35
1.30	(2) .35
1.50	(1) .35 + (1) .15 or (1) + (1) .5 or (3) .5
1.65	(1) + (1) .35 or (2) .5 + (1) .35
1.70	(2) .15
1.80	(2) .35 + (1) .5
1.85	(1) + (1) .15
1.95	(3) .35
2.00	(2)

\* For a room with more than two (2) terminals, combinations of the above may be used to achieve the desired fractional number.

C. Supply Tubing Length: An outlet with a supply tubing length of 15 feet is considered one, fully opened outlet. For other lengths refer to Figure 3.3 for adjustment factors.

**FIGURE 3.3**

2" SUPPLY TUBING LENGTH ADJUSTMENT FACTOR CHART								
RUN	6'	8'	10'	12'	15'	20'	25'	30'
FACTOR	.85	.88	.90	.94	1.0	1.1	1.25	1.50

# SECTION 4: MAINTENANCE

The SpacePak system has been designed to provide years of trouble-free performance in normal installations. Examination by the homeowner at the beginning of each cooling season, and in mid-season should assure continued, good performance. In addition, the system should be examined by a qualified service professional at least once every year.

## BEFORE EACH COOLING SEASON

1. Check and clean air filter. The air filter is permanent type. Remove and clean thoroughly with soap solution and water.

**▲ WARNING** Turn off electrical power supply before servicing. Contact with live electric components can cause shock or death.

2. Check fan coil unit. Turn off unit power disconnect switch and remove service access panels.

a. Inspect coil and blower wheel for build-up of dust and dirt. Clean with solvent and/ or water as necessary.

b. Replace service access panels and turn on unit power disconnect switch.

3. Check that unit condensate drain is clear and free running, and plug is in cleanout.

4. For chiller or boiler unit, follow manufacturer's maintenance instructions.

5. Follow "System Start-Up & Adjustments" procedures in Section 3 of this manual.

## IF SYSTEM FAILS TO OPERATE

1. Check that thermostat switch is set for proper mode of operation and is set below room temperature.

2. Check that chiller or boiler unit is operating.

3. Check for tripped circuit breaker or blown fuse at the main fuse box. Reset breaker or replace blown fuse with same size and type.



Service / Troubleshooting FORM "1A"

Customer / Dealer Data:

Name: \_\_\_\_\_

Address: \_\_\_\_\_

\_\_\_\_\_  
\_\_\_\_\_

Tel (day) \_\_\_\_\_ (eve) \_\_\_\_\_

Installing Dealer / Contractor:

Name: \_\_\_\_\_

Tel: \_\_\_\_\_

Equipment Data:

SPACEPAK Model # ESP / WCSP - \_\_\_\_\_

SPACEPAK Serial # \_\_\_\_\_

SPACEPAK Date of Installation: \_\_\_\_\_

Cond Unit Mfr: \_\_\_\_\_

Cond Unit Mod #: \_\_\_\_\_

Rated Capacity: \_\_\_\_\_ BTUH; SEER: \_\_\_\_\_

Air-side Data:

Total # of outlets: \_\_\_\_\_; Supply tube length: \_\_\_\_\_ Ft (avg)  
(Please sketch duct layout on reverse side of this sheet, noting all fittings and distances, including return duct size / length)

Air Filter: Size (LxHxD) \_\_\_\_\_

Type (pleated, etc): \_\_\_\_\_

Is the filter clean? \_\_\_\_\_ (Y/N)

Static Pressure (Ps) in supply plenum: \_\_\_\_\_ "WG  
(Measure at approximately 3 ft downstream of blower discharge)

Ps in return duct (downstream of filter, upstream of coil) \_\_\_\_\_ "WG

SpacePak Motor: Amps (measured): \_\_\_\_\_ Amps

Voltage (measured): \_\_\_\_\_ Volts

Air Temperatures:

@ Return (indoor ambient): \_\_\_\_\_ °FDB; \_\_\_\_\_ °FWB

@ Condensing unit (outdoor ambient): \_\_\_\_\_ °F

@ AHU (read 3 ft from fan discharge) \_\_\_\_\_ °F

@ last supply outlet \_\_\_\_\_ °F

Refrigeration-side Data:

Line sizes: Liquid \_\_\_\_\_ Suction \_\_\_\_\_

Total equivalent length of lines: \_\_\_\_\_ Ft; Vertical Rise: \_\_\_\_\_ Ft.

@ Condensing Unit:

Liquid: \_\_\_\_\_ psi; Temp: \_\_\_\_\_ °F; Subcool: \_\_\_\_\_ °F

Suction: \_\_\_\_\_ psi; Temp: \_\_\_\_\_ °F; Superheat: \_\_\_\_\_ °F

@ SpacePak:

Liquid: \_\_\_\_\_ psi; Temp: \_\_\_\_\_ °F; Subcool: \_\_\_\_\_ °F

Suction: \_\_\_\_\_ psi; Temp: \_\_\_\_\_ °F; Superheat: \_\_\_\_\_ °F

Approximate time running before taking readings: \_\_\_\_\_ Hrs.

Did you adjust the TXV? \_\_\_\_\_ (Y/N); (If yes, explain):

\_\_\_\_\_  
\_\_\_\_\_  
\_\_\_\_\_

Refrigerant Charge (if weighed-in): \_\_\_\_\_ lbs

R410a / R22 (circle one)

Installed options: (circle one)

sight glass filter/drier zone controls

Other: \_\_\_\_\_

\_\_\_\_\_

Water Data: (where applicable)

Line sizes: \_\_\_\_\_"; Length: \_\_\_\_\_ FT

Water temperatures:

Supply: \_\_\_\_\_ °F; Return \_\_\_\_\_ °F

Glycol?: \_\_\_\_\_ (Y/N); % Solution: \_\_\_\_\_

NOTES: \_\_\_\_\_

\_\_\_\_\_

\_\_\_\_\_

\_\_\_\_\_

\_\_\_\_\_

REF. NO.	PART DESCRIPTION	UNIT SIZE	PART NUMBER
2	Primary Drain Pan	2430	W06RWG0220-02
	Primary Drain Pan	3642	W06RWG0220-03
	Primary Drain Pan	4860	W06RWG0220-04
3	Coil Assembly	2430	469RWG0379-12
	Coil Assembly	3642	469RWG0379-13
	Coil Assembly	4860	469RWG0379-14
5	Transformer	All Sizes	W14RWG0061-01
6	Motor	2430	27-3236
	Motor	3642	27-3237
	Motor	4860	27-3238
7	Blower Wheel	2430	27-8032
	Blower Wheel	3642	27-8032
	Blower Wheel	4860	27-8033
8	Terminal Block (high volt)	All Sizes	W09RWG0422-01
9	Electrical Control Box Cover	All Sizes	462RWG0529-01
10	Side Access Panel (coil side)	All Sizes	462RWG0527-01
11	Primary Float Switch	All Sizes	455RWG0543-01
12	Cable Connector (Ground)	All Sizes	W09RWG0313-01
13	Control Board	All Sizes	W11RWG0478-01

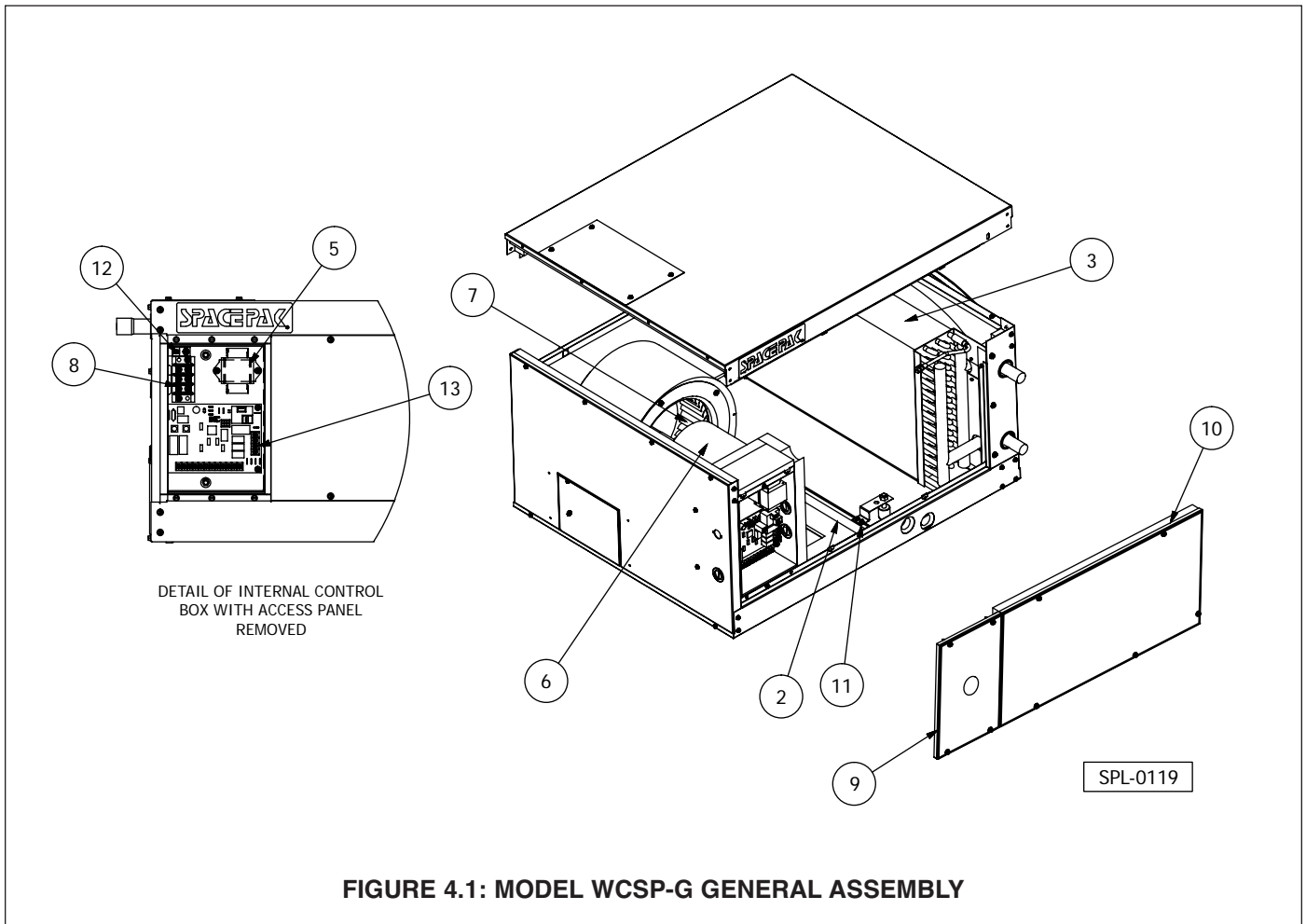

## **LIMITED WARRANTY**

### **Central Air Conditioning Products**

The "Manufacturer" warrants to the original owner at the original installation site that the Central Air Conditioning Products (the "Product") will be free from defects in material or workmanship for a period not to exceed one (1) year from the startup or eighteen (18) months from date of shipment from the factory, whichever occurs first. If upon examination by the Manufacturer the Product is shown to have a defect in material or workmanship during the warranty period, the Manufacturer will repair or replace, at its option, that part of the Product which is shown to be defective.

This limited warranty does not apply:

- a) if the Product has been subjected to misuse or neglect, has been accidentally or intentionally damaged, has not been installed, maintained or operated in accordance with the furnished written instructions, or has been altered or modified in any way.
- b) to any expenses, including labor or material, incurred during removal or reinstallation of the defective Product or parts thereof.
- c) to any workmanship of the installer of the Product.

This limited warranty is conditional upon:

- a) shipment, to the Manufacturer, of that part of the Product thought to be defective. Goods can only be returned with prior written approval from the Manufacturer. All returns must be freight prepaid.
- b) determination, in the reasonable opinion of the Manufacturer, that there exists a defect in material or workmanship.

Repair or replacement of any part under this Limited Warranty shall not extend the duration of the warranty with respect to such repaired or replaced part beyond the stated warranty period.

**THIS LIMITED WARRANTY IS IN LIEU OF ALL OTHER WARRANTIES, EITHER EXPRESS OR IMPLIED, AND ALL SUCH OTHER WARRANTIES, INCLUDING WITHOUT LIMITATION IMPLIED WARRANTIES OF MERCHANTABILITY OR FITNESS FOR A PARTICULAR PURPOSE, ARE HEREBY DISCLAIMED AND EXCLUDED FROM THIS LIMITED WARRANTY. IN NO EVENT SHALL THE MANUFACTURER BE LIABLE IN ANY WAY FOR ANY CONSEQUENTIAL, SPECIAL, OR INCIDENTAL DAMAGES OF ANY NATURE WHATSOEVER, OR FOR ANY AMOUNTS IN EXCESS OF THE SELLING PRICE OF THE PRODUCT OR ANY PARTS THEREOF FOUND TO BE DEFECTIVE. THIS LIMITED WARRANTY GIVES THE ORIGINAL OWNER OF THE PRODUCT SPECIFIC LEGAL RIGHTS. YOU MAY ALSO HAVE OTHER RIGHTS WHICH MAY VARY BY EACH JURISDICTION.**

