



SQUARE FIBERBOARD PLENUM DUCT INSTALLATION MANUAL



SECTION 1: INTRODUCTION	1	Horizontal Discharge	2
Square Fiberboard Plenum Duct Components	2	Vertical Discharge	2-3
SECTION 2: INSTALLATION	2	Step 4: Installing Air Distribution Components	3
Step 1 and 2:	1	Plenum Duct Installation	3-4
Step 3: Attaching Supply Air Plenum Adaptor	2	Plenum Take-Off Installation	4

SECTION 1: INTRODUCTION

The following terms are used throughout this manual to bring attention to the presence of potential hazards or to important information concerning the product:

NOTICE: Used to notify of special instructions on installation, operation or maintenance which are important to equipment but not related to personal injury hazards.

SECTION 2: INSTALLATION

STEPS 1 AND 2: REFER TO FAN COIL UNIT INSTALLATION MANUAL

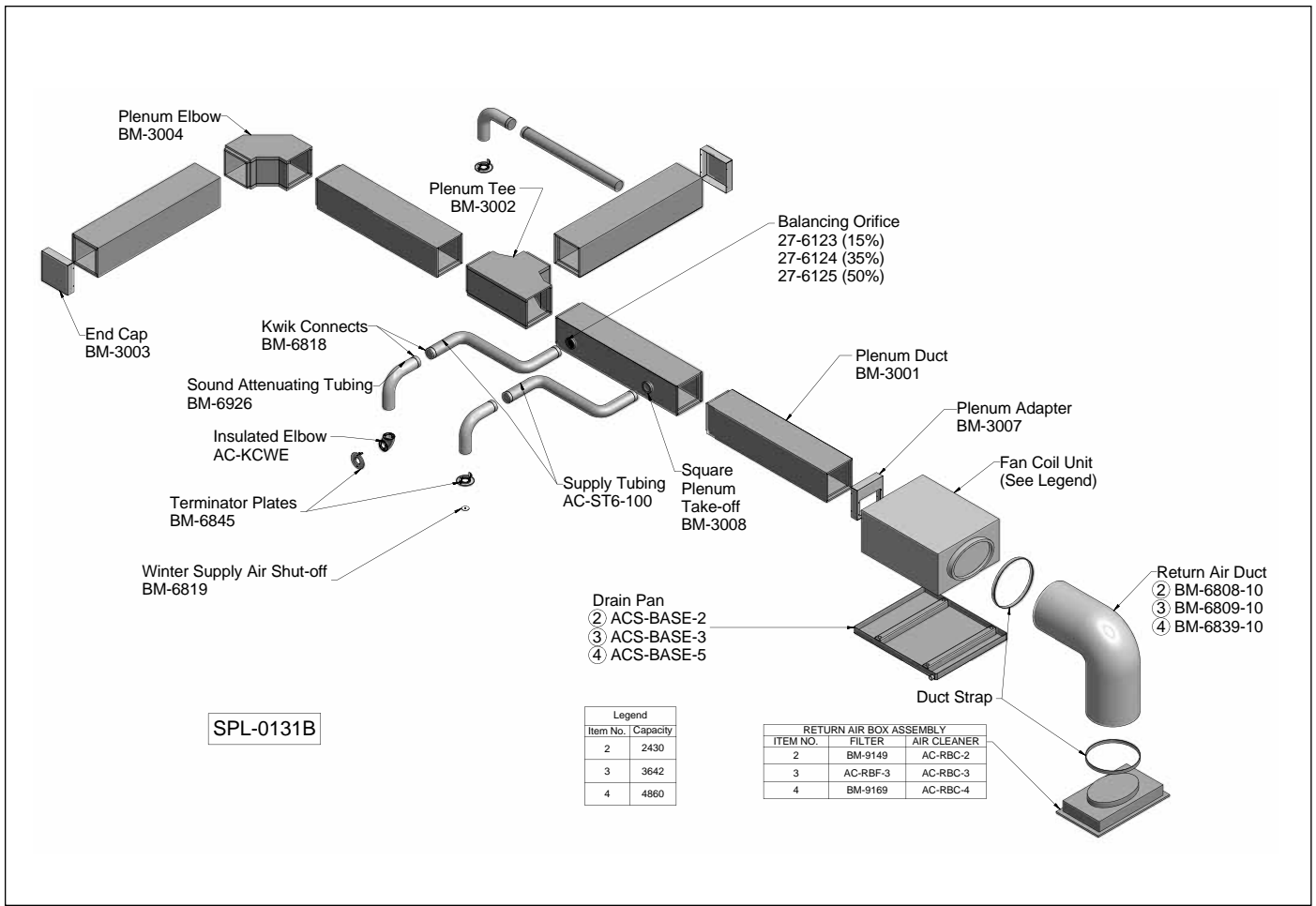

STEP 3: ATTACHING SUPPLY AIR SQUARE PLENUM ADAPTOR (BM-3007)

NOTE: If unit is to be located in the attic and installed through ceiling joists, attach supply air plenum adaptor in attic.

A. HORIZONTAL DISCHARGE: Refer to Figure 2.8.

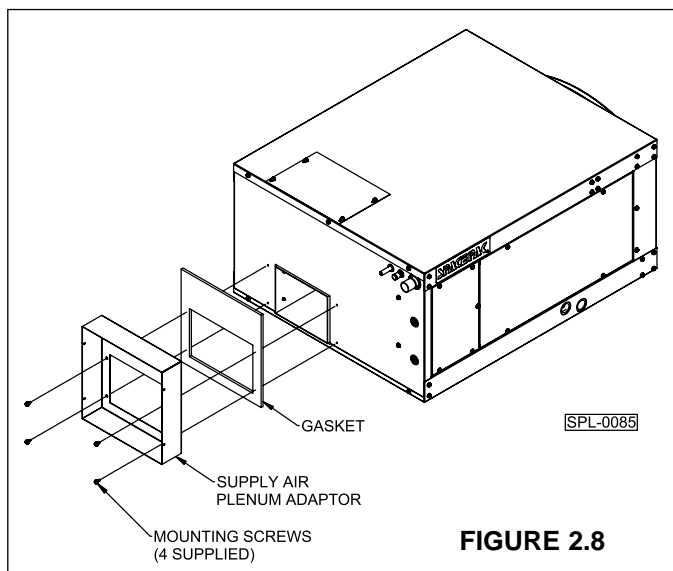

B. TO CONVERT TO VERTICAL DISCHARGE: Refer to Figure 2.9A & 2.9B

Tools required: 1/4", 5/16", 3/8", 7/16" box wrenches and nut drivers, 5/32" Allen wrench, utility knife & Malco S-3 offset hand seamer (3" duct-bill pliers).

Field supplied: latex caulk, UL classified duct liner adhesive (or equivalent).

NOTICE: An Electric Heat Module cannot be installed after unit has been field converted to vertical supply air discharge (due to resulting blower housing obstruction).

Refer to Figure 2.9A for Steps 2 to 8a.

1. Place unit horizontally on a flat raised surface.
2. Remove all side access panels, return air panel and cover plate from top panel.
3. Remove top panel by removing top/center screw from electric control box and panel screws.
4. Remove (4) screws securing front panel flange to blower housing.
5. Remove sealant around discharge opening.
6. Remove (3) remaining screws from electrical control box. Set box aside.
7. Remove (2) screws attaching blower housing to motor support channel flange.
- 8a. Remove (6) screws attaching motor mounting base to motor support channel.

Refer to Figure 2.9B for Steps 8b to 18.

- 8b. Shift motor mounting base (and blower housing) back toward coil to second set of mounting lugs on motor support channel. Rotate blower housing up 90°. Reattach base with screws.
9. Cut insulation from discharge air location on top panel (opening dimensions shown in Figure 2.3 of unit manual). Insert cut piece into opening. Apply adhesive per manufacturer's instructions. Attach cover plate to front of unit.
10. Bend both flanges 90° into cabinet using 3" duct-bill pliers. Pliers should engage full jaw depth (1-1/4") and be centered on flange.
11. Insert blower housing into top panel. Reattach panel to unit.
12. Align hole in blower housing with lower slot in motor support channel flange. Attach housing to flange with (1) previously removed screw.
13. Align (4) holes in top panel flange with holes in blower housing. Attach with removed screws.

14. Assure blower wheel is centered in inlet and discharge of blower housing. If required, adjust by loosening (4) bolts securing motor. Shift motor and refasten. For blower wheel adjustments, loosen set screw (not shown), shift wheel and refasten.
15. Apply latex caulk to seal between blower housing and top panel.
16. Reinstall electrical control box.
17. Place supply air plenum adaptor over discharge opening. Align holes in plenum adaptor, gasket and top panel. Secure with screws provided with adaptor.

NOTICE: Check that all inside cabinet surfaces are covered with insulation, add insulation if required. An uninsulated panel will "sweat" and condensate will form on the cabinet.

18. Replace all panels and screws.

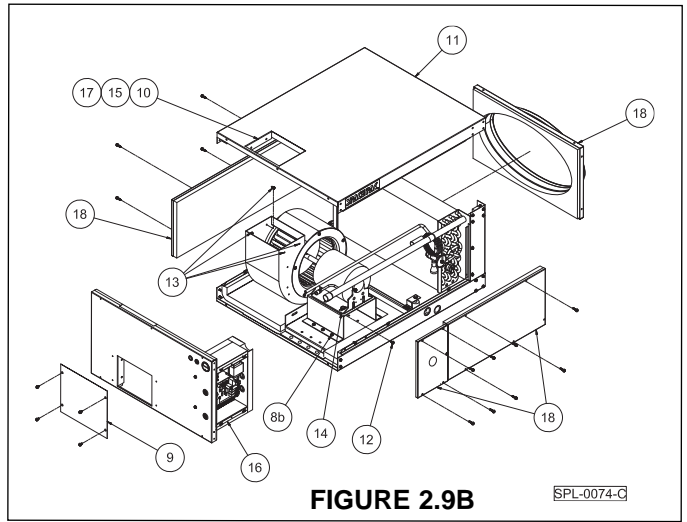
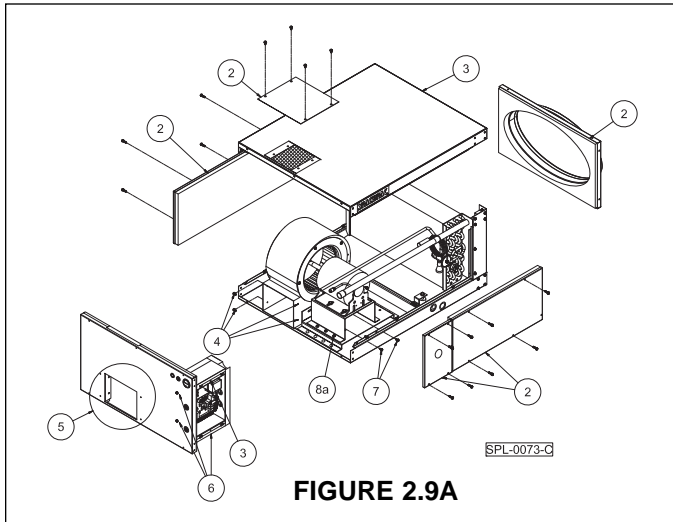

STEP 4: INSTALLING AIR DISTRIBUTION COMPONENTS

All plenum duct and supply tubing runs as well as room terminator locations must be in accordance with air distribution system requirements listed in Section 1 of fan coil unit installation, operation and maintenance manuals. Where taping of joints is required, use UL181 approved tape.

Plenum Duct Installation

All tees, elbows and branch runs must be a minimum of 24" from the fan coil unit or any other tee, elbow or branch run. Keep all tees and elbows to a minimum to keep system pressure drop on larger layouts to a minimum. Square plenum duct comes in 4-foot sections and may be cut to length.

Begin installing plenum duct (see Figure 2.14). For straight or branched plenum run cut off the female end of a plenum duct section. In the case of a bull head tee (see Unit No. 1 in Figure 1.3 of installation manuals) cut off the male end of a plenum duct section. Then insert duct into fan coil unit plenum adaptor. Push duct in tight to form snug joint, and insert flat head pins. Remove paper backing on rectangular foam pieces and place over pin heads. Tape the unit/plenum joint securely. To prevent air leakage and condensation, wrap and tape in place the 6" wide piece of foil faced fiberglass insulation over the taped joint. Be sure insulation is pushed up against the unit.

Continue to assemble plenum duct, making sure shiplap joints (see Figure 2.15) are snug and taped securely. Remember, for the ESP-4860V system, a plenum "H" (Part Number BM-3006) should be installed before continuing plenum duct run (see air distribution system requirements in Section 1 of fan coil unit manual).

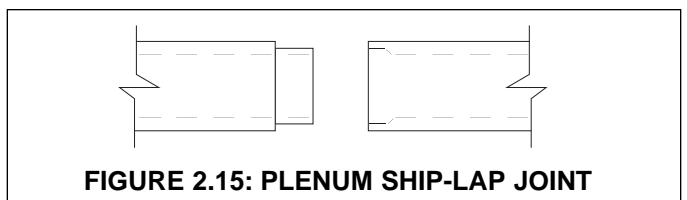
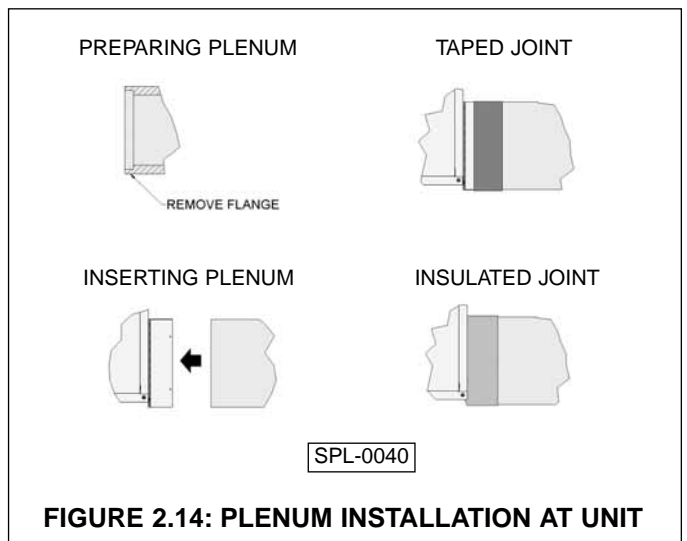

Plenum tee and elbow fittings may be installed at any point in the plenum duct run. If installing a fitting at the end of a full plenum section (see Figure 2.16), insert female end of fitting onto duct. If installing a fitting at a "cut" in the plenum duct (see Figure 2.16), form a field-fabricated flange (1-1/2" wide) in the duct and insert male end of fitting into duct. Tape the joint securely.

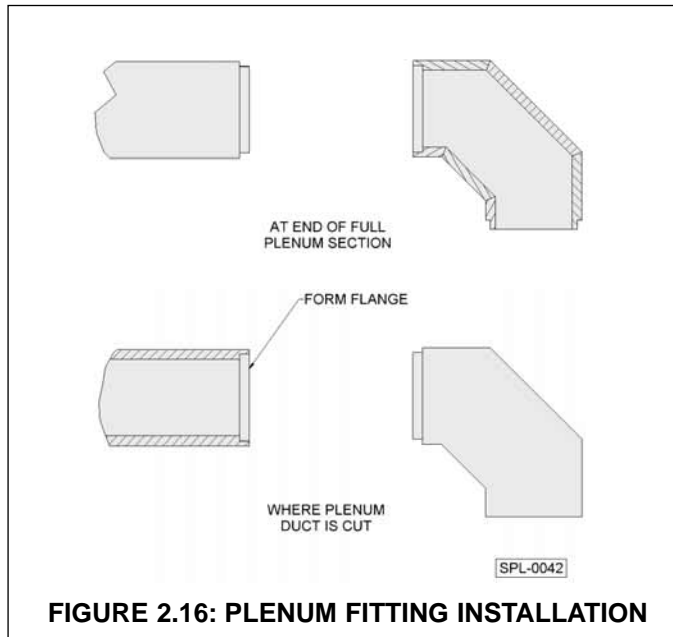

FIGURE 2.16: PLENUM FITTING INSTALLATION

An end cap must be installed at the end of each duct run. The cap contains an insulating cushion which is pushed up tight against the duct end. (If installing end cap at the end of a full plenum section, remove shiplap joint first). Holding cap firmly in place (see Figure 2.17), insert flat head pins through the holes in the end cap. Remove paper backing on rectangular foam pieces and place over pin heads. Tape cap to the plenum duct, completely around the seam.

NOTICE: Installation of endcaps should be completed after all plenum take-offs have been installed. The duct shavings produced with take-off installation will be blown into the space to be conditioned if sealed into duct system.

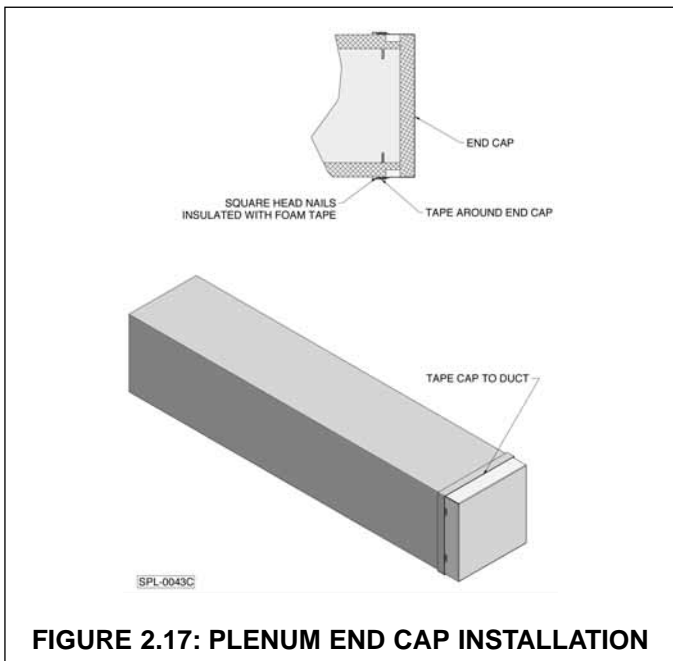

FIGURE 2.17: PLENUM END CAP INSTALLATION

At the plenum location selected for attaching the supply tubing, cut a 2" diameter hole in the plenum with the SpacePak plenum hole cutter (see Figure 2.24).

Rotate the cutter (Part Number BM-6822) as pressure is applied to force the serrated edge through the aluminum foil and insulation. Remove the hole cut-out from the plenum. Make sure there is no "flap" left inside plenum that could block hole during operation.

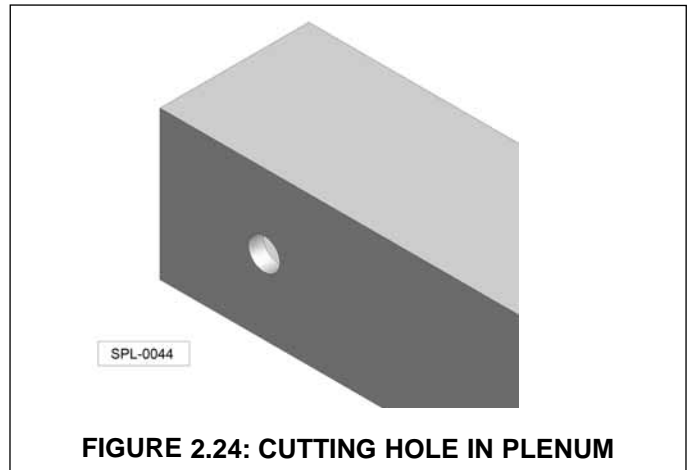

FIGURE 2.24: CUTTING HOLE IN PLENUM

Place the plenum take-off gasket on the back side of the plenum take-off and insert the assembly into the hole in the plenum. Hand insert the four plenum take-off fasteners one at a time such that each clip reaches the interior of the duct. Using the SpacePak pliers, snap the fasteners into place until they lock securely (see Figure 2.26).

NOTICE: Gasket must be installed to seal plenum take-off to prevent air leakage.

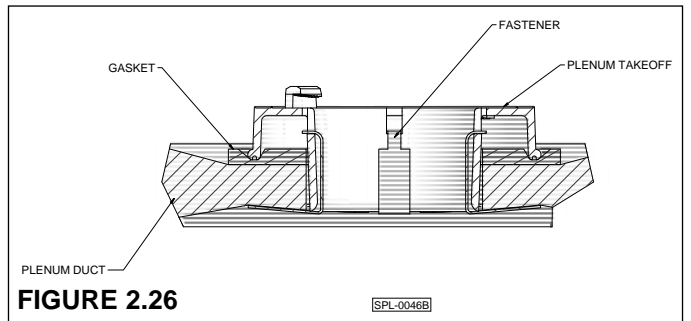

FIGURE 2.26

NOTICE: All four fasteners must be installed to assure air tight fitting between plenum take-off and plenum.

Installation instructions for room terminators, sound attenuating tubing and supply tubing are provided in installation manual supplied with fan coil unit (Section 2).