



MODEL ESP-G SYSTEM INSTALLATION, OPERATION & MAINTENANCE MANUAL



**Central Air Conditioning Series
2 to 5 Tons
Fan Coil Unit/Air Supply
Components**

SECTION 1: INTRODUCTION		Step 7: Wiring The Unit.....	12
SpacePak System Design.....	2	Step 8: Installing Air Distribution Components.....	12-17
Code Compliance.....	2	SECTION 3: START UP & OPERATION	
Air Distribution Requirements.....	2	Sequence Of Operation.....	18
Model Number Description.....	2	Prior To Start-Up.....	18
Air Distribution Components.....	3-5	System Start-Up & Adjustments.....	18
Warranty Information.....	Back Page	Charging Cooling Only Systems.....	18
Shipment of Unit.....	5	Factors Affecting the Balance of the System.....	19
SECTION 2: SYSTEM INSTALLATION		SECTION 4: MAINTENANCE	
Step 1: Locating The Unit.....	6	Before Each Cooling Season.....	20
Step 2: Cutting Return Air Opening.....	8	If System Fails To Operate.....	20
Step 3: Attaching Supply Air Plenum Adaptor.....	9	Troubleshooting Guide.....	21-25
Step 4: Setting The Unit.....	11	Service/Troubleshooting Form.....	26
Step 5: Connecting Refrigerant Lines.....	11	Parts List.....	27
Step 6: Installing The Condensate Trap & Line.....	12		



IN UNITED STATES: 260 NORTH ELM ST. WESTFIELD, MA 01085 (413) 564-5530/FAX (413) 564-5815
 IN CANADA: 7555 TRANMERE DRIVE, MISSISSAUGA, ONTARIO, L5S 1L4 (905) 672-2991/FAX (905) 672-2883

Section 1: INTRODUCTION

The following terms are used throughout this manual to bring attention to the presence of potential hazards or to important information concerning the product:

▲ DANGER Indicates an imminently hazardous situation which, if not avoided, will result in death, serious injury or substantial property damage.

▲ WARNING Indicates an imminently hazardous situation which, if not avoided, could result in death, serious injury or substantial property damage.

▲ CAUTION Indicates an imminently hazardous situation which, if not avoided, may result in minor injury or property damage.

NOTICE: Used to notify of special instructions on installation, operation or maintenance which are important to equipment but not related to personal injury hazards.

SPACEPAK SYSTEM DESIGN

SpacePak is a hi-velocity central air conditioning system which utilizes a conventional outdoor condensing unit matched with the indoor Model ESP-G fan coil unit to provide conditioned air through the specially-designed, pre-fabricated, pre-insulated flexible duct system. The system and its basic components operate the same as in any conventional air-to-air cooling system.

The SpacePak system is covered by the following U.S. Patents: 3,507,354; 3,575,234; 3,596,936; 3,605,797; 3,685,329; 4,045,977; 4,698,982; 926,673 and Canadian Patents: 891,292; 923,935; 923,936.

CODE COMPLIANCE

Fan coil unit installation must conform to the requirements of the local authority having jurisdiction or, in the absence of such requirements, to the National Board of Fire Underwriters regulations. Fan coil unit meets ETL listing requirements.

All electrical wiring must be in accordance with the National Electrical Code ANSI/NFPA No. 70-latest edition and any additional state or local code requirements. If an external electrical source is utilized, the fan coil unit, when installed, must be electrically grounded.

NOTICE: It is a requirement of the International Mechanical Code (307.2.3) to install a secondary drain or an auxiliary drain pan where damage to any building components will occur as a result of overflow from the equipment drain pan or stoppage in the condensate drain piping from a cooling or an evaporator coil. Follow local code requirements.

AIR DISTRIBUTION SYSTEM COMPONENT REQUIREMENTS

Air distribution components installation must conform to the requirements of local authority having jurisdiction or, in the absence of such requirements, to the National Fire Protection Association 90A or 90B.

Do not begin the installation of the system without performing a load calculation to determine heat gain, system layout and material take-off. If a layout plan is not already available and room terminator requirements determined, then refer to the SpacePak Application Manual, SP9, to complete this information. A description of air distribution system components is shown in Figure 1.1.

SpacePak - Model Number Description

1	2	3	4	5	6	7	8	9	10
UT			CA				SE	CT	RT

1,2,3 - Unit Type [UT]

ESP - Evaporator DX Fan Coil Unit

4,5,6,7 - Capacity [CA]

2430 - 24,000 to 30,000 BTU/Hr. (2-2½ tons)

3642 - 36,000 to 42,000 BTU/Hr. (3-3½ tons)

4860 - 48,000 to 60,000 BTU/Hr. (4-5 tons)

8 - Series [SE]

G - "G" series

9 - Cabinet Type [CT]

H - Horizontal

10 - Refrigerant Type [RT]

4 - R410A

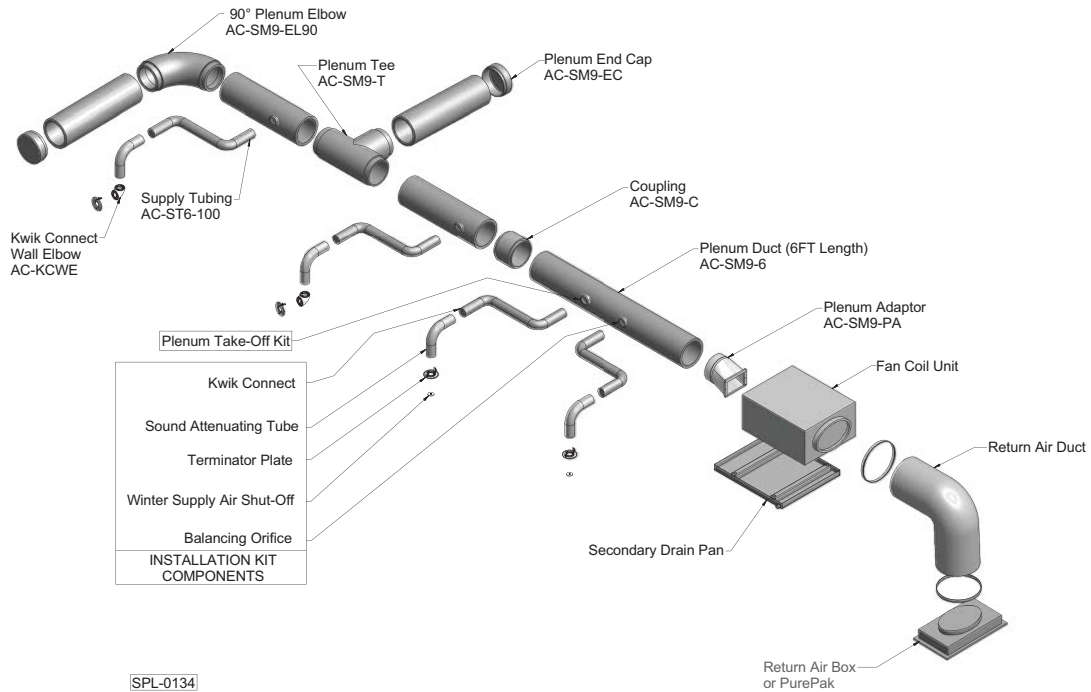

RETURN AIR BOX (BM-9149, AC-RBF-3, BM-9169): Each includes filter grill with metal frame, permanent filter, and 2 clamp bands. BM-9149 is for ESP-2430G. AC-RBF-3 is for ESP-3642G and BM-9169 is for ESP-4860G.

RETURN AIR DUCT (BM-6808-10, BM-6809-10, BM-6839-10): Flexible, 10 feet long with round shape. BM-6808-10 (15" dia.) for ESP-2430G. BM-6809-10 (19" dia.) for ESP-3642G and BM-6839-10 (24" dia.) is for ESP-4860G.

PLENUM ADAPTOR: 9" round OR 10" X 10" square metal component to attach plenum duct to fan coil unit.

PLENUM DUCT & COMPONENTS: May be 9" round sheet metal or 10" X 10" (O.D.) square, fiberboard duct types as specified by the installing contractor. Above layout is shown as an illustrative assembly reference only.

R6 SUPPLY TUBING (AC-ST6-100): Flexible, R6 insulated, 2" I.D. and 3-1/4" O.D. Each section is 100 feet long.

R8 SUPPLY TUBING (AC-ST8-75): Flexible, R8 insulated, 2" I.D. and 5-3/8" O.D. Each section is 75 feet long.

INSTALLATION KITS: Contains a specified amount of sound attenuating tubes, kwik-connects, terminator

plates (incl. spring clips & screws), winter supply air shut-offs and a balancing orifice set to complete installation of room outlets. Supplied in (2) and (5) outlet boxed quantities.

PLENUM TAKE-OFF KIT: Contains a specific amount of plenum take-offs, gaskets and fasteners to complete installation of room outlets. Take-offs available for round sheet metal or square fiberboard duct as specified by installing contractor. Supplied in (2) and (5) outlet boxed quantities.

KWIK CONNECT 90° WALL ELBOW (AC-KCWE): To allow for wall terminations in 2" X 4" stud spaces.

SECONDARY DRAIN PAN: Specifically sized for SpacePak horizontal fan coil units. Constructed of durable polyethylene. Fan coil unit sets directly on top and can be installed with threaded rod.

PLIERS (SPC-72): To assure full setting of all clips (fasteners) in plenum take-off (not shown).

PLENUM HOLE CUTTER (SPC-71-10): To cut 2" hole in fiber board for plenum take-off installation (not shown).

FIGURE 1.1: AIR DISTRIBUTION SYSTEM COMPONENTS

Plenum Duct

The plenum duct can be run in practically any location accessible for the attachment of the supply tubing (see suggested layouts in Figure 1.2). The plenum is normally located in the attic or basement, and it is usually more economical to run the plenum where it will appreciably shorten the lengths of two or more supply runs.

In some two-story split level homes, it may be advantageous to go from one level to another with the plenum duct. Whenever necessary, either between floors or along the ceiling, the small size of the plenum makes it easy to box in.

The fan coil unit is designed to operate with a total external static pressure of 1.5 inches of water column (minimum 1.2 - maximum 1.5). Excessive static pressure increases the air flow in individual runs and may cause some or all terminators to be noisy.

For systems designed with a bullhead tee installed as on Unit No. 1 (Figure 1.3), the best results are obtained if not more than 60% of the total number of system outlets are attached to any one branch of the tee. For systems with a branch tee installed as on Unit No. 2 (Figure 1.3), not more than 30% of the total number of system outlets should be attached to the perpendicular branch of the tee.

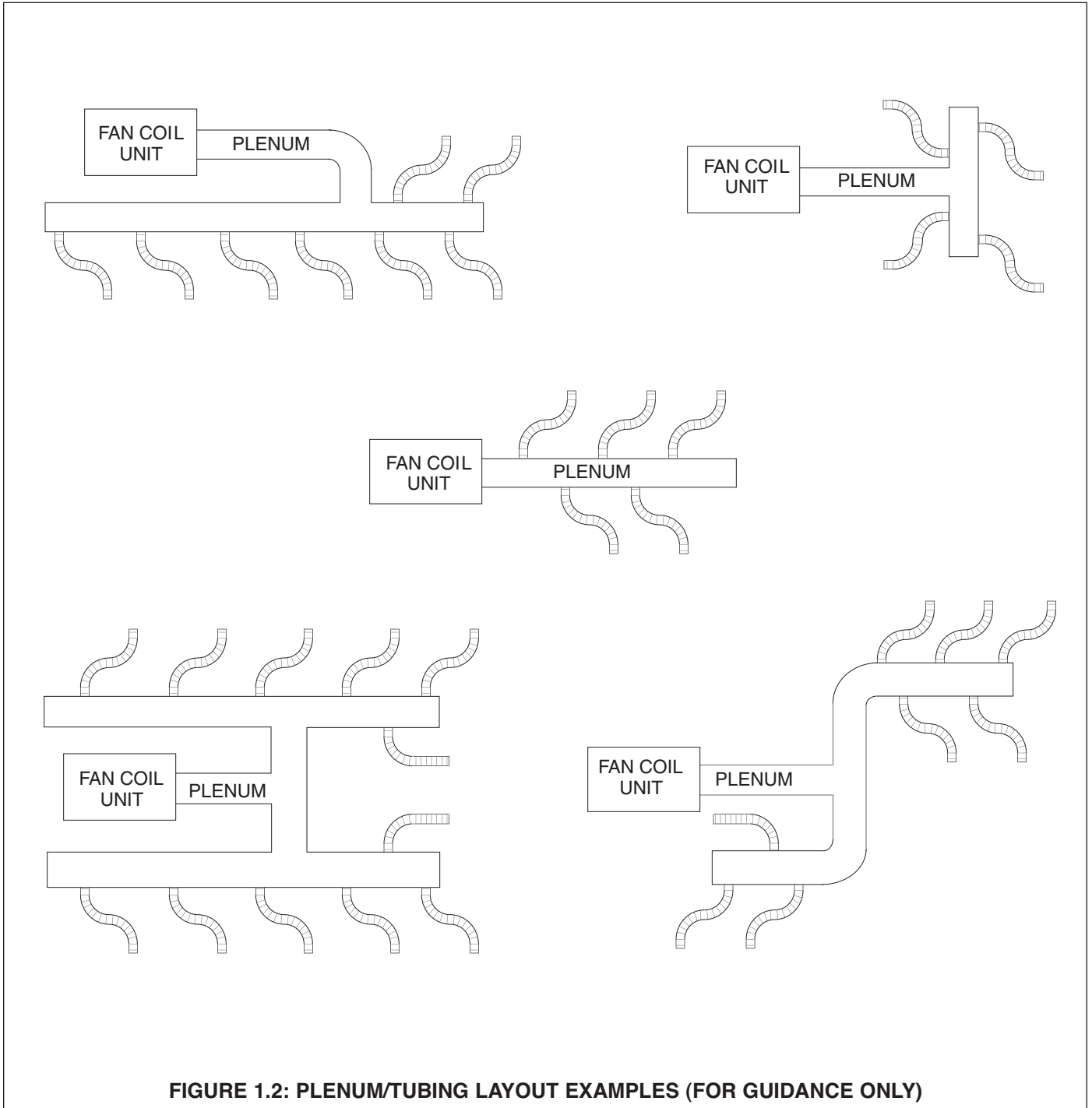
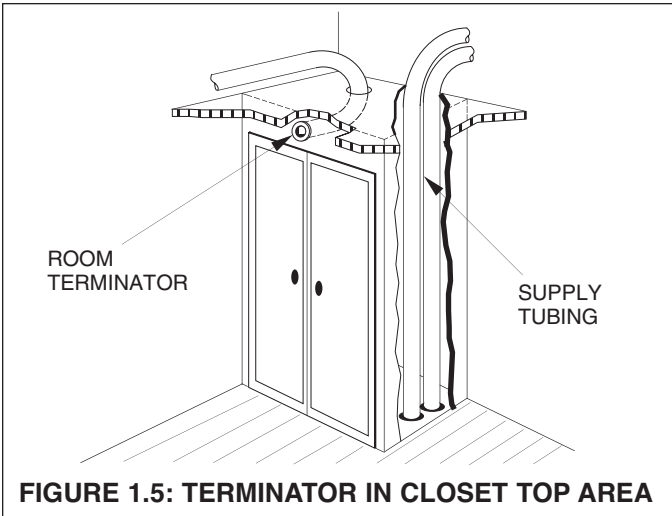
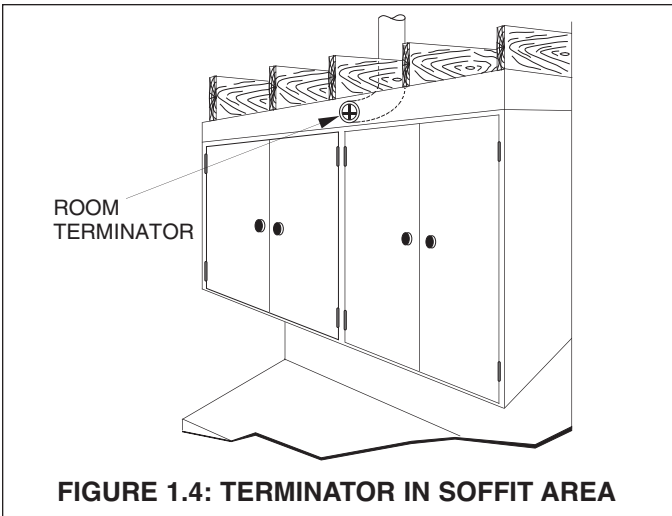
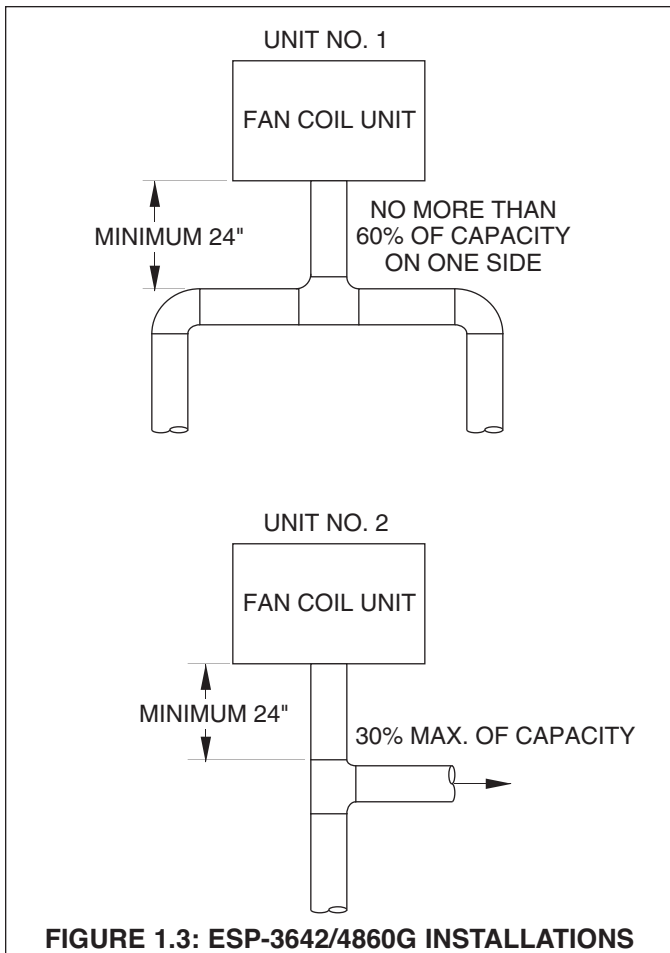

FIGURE 1.2: PLENUM/TUBING LAYOUT EXAMPLES (FOR GUIDANCE ONLY)



The larger system capacities (ESP-3642/4860G) are effected more by higher system static pressure than the smaller systems. Installation of the plenum tee closer than the minimum indicated in Fig. 1.3 will reduce performance of the system. No supply runs should be installed between unit outlet and this tee. Static readings on system should be taken before tee.

Supply Tubing

In the case of two-story or split-level applications, supply tubing may run from one story to another. It is small enough to go in stud spaces, but this is often difficult in older homes because of hidden obstructions in stud spaces. It is more common to run the supply tubing from the attic down through second story closets to the first story terminators.

Supply tubing runs in the corners of the second story rooms can be boxed in and are hardly noticeable since overall diameter is only 3-1/4".

Room Terminators

Terminators should be located primarily in the ceiling or floor for vertical discharge or high on a wall for horizontal discharge. Installation of horizontally discharged terminators is assisted with the SpacePak 90° wall elbow (see page 15). Two excellent spots for horizontal discharge are in the soffit area above kitchen cabinets (see Figure 1.4) and in the top portion of closets (see Figure 1.5).

Terminators should always be out of normal traffic patterns to prevent discharge air from blowing directly on occupants. And they should not be located directly above shelves or large pieces of furniture. Outside wall or corner locations are recommended if the room has more than one outside wall. Locating terminators away from interior doors prevents short cycling of air to the return air box.

SHIPMENT OF UNIT

Each fan coil unit is shipped in a single carton. Packed with the unit, there are vibration isolation pads, a condensate trap assembly and a factory installed primary float switch.

SECTION 2: SYSTEM INSTALLATION

NOTICE: Before proceeding with the installation, we recommend reading through this section of the manual for an overall understanding of the air conditioning fan coil unit and air distribution system component installation procedures.

The fan coil unit is shipped in a horizontal air flow arrangement, but can be easily field-converted to a vertical air flow arrangement as detailed on page 9 and Figures 2.8 and 2.9.

STEP 1: LOCATING THE UNIT

The fan coil unit may be installed in an unconditioned space (as long as it is protected from the weather) such as an attic, garage or crawlspace, or a conditioned space such as a basement, closet or utility room (see dimensions in Figures 2.2 and 2.3).

When selecting a location, consider the locations (as shown in Figures 2.4, 2.5 and 2.6) of the return air box; routing of the plenum duct, supply tubing, refrigerant lines, condensate drain line; and all recommended clearances (see Figures 2.2 and 2.3).

Model	System capacity (Nom. Tons)	Electrical Characteristics	Connections				Recommended Condensing Unit	
			Suction Line (O.D.)	Liquid Line (O.D.)	Cond. Drain (FPT)	Return Inlet (Dia.)	Nominal Capacity (MBH)	Min SEER
ESP-2430G	2 - 2-1/2	208-230/60/1	7/8"	3/8"	3/4"	15"	24 to 30	13+
ESP-3642G	3 - 3-1/2	208-230/60/1	7/8"	3/8"	3/4"	19"	36 to 42	13+
ESP-4860G	4 & 5	208-230/60/1	7/8"	3/8"	3/4"	24"	48 to 60	13+

Model	System capacity (Nom. Tons)	Blower					Coil			Ship. Wt. (lbs)
		Air Volume @ 1.5" W.C. (SCFM)	Wheel Dia. and Width	Motor HP	Motor Type	F.L. Amps	No. of Rows Deep	Holding Charge (Dry Nitrogen)	Flow Control Type	
ESP-2430G	2 - 2-1/2	550	9" x 5"	1/3	PSC	1.8	6	7 psi	Exp. Valve	120
ESP-3642G	3 - 3-1/2	850	9" x 5"	1/2	PSC	2.8	6	7 psi	Exp. Valve	144
ESP-4860G	4 & 5	1150	9" x 6-3/8"	1	PSC	5.3	6	7 psi	Exp. Valve	171

FIGURE 2.1: MODEL ESP-G SPECIFICATIONS

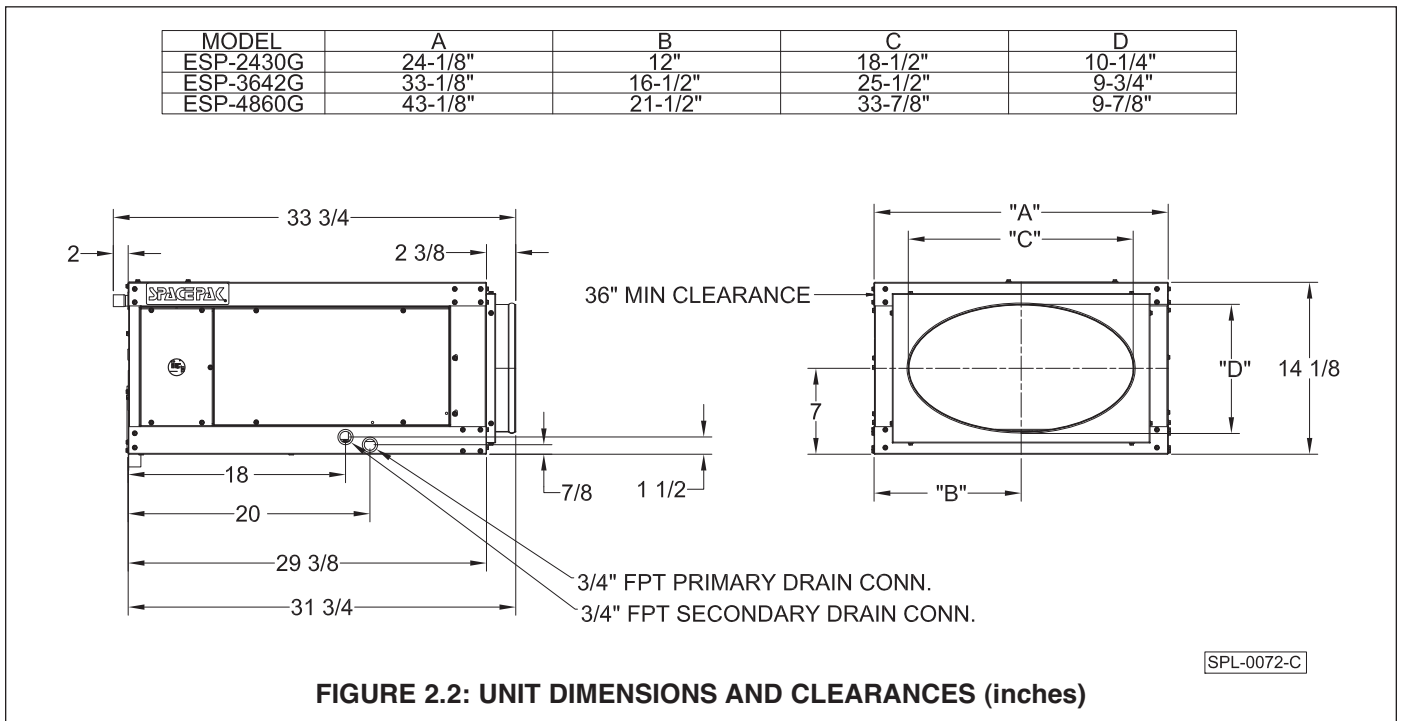

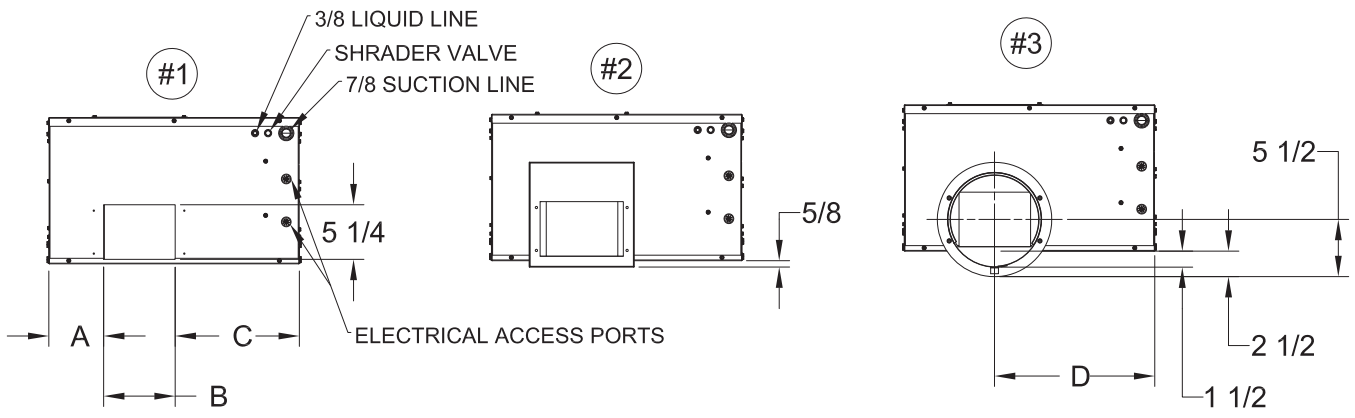

SPL-0077B

MODEL	A	B	C	D
ESP-2430G	5-1/4	6-1/2	12-1/2	15-3/4
ESP-3642G	7-1/2	6-1/2	19	22-1/4
ESP-4860G	17-7/8	7-5/8	17-5/8	21-7/16

FIGURE 2.3: CONNECTION LOCATIONS AND ASSEMBLED PLENUM ADAPTOR DIMENSIONS

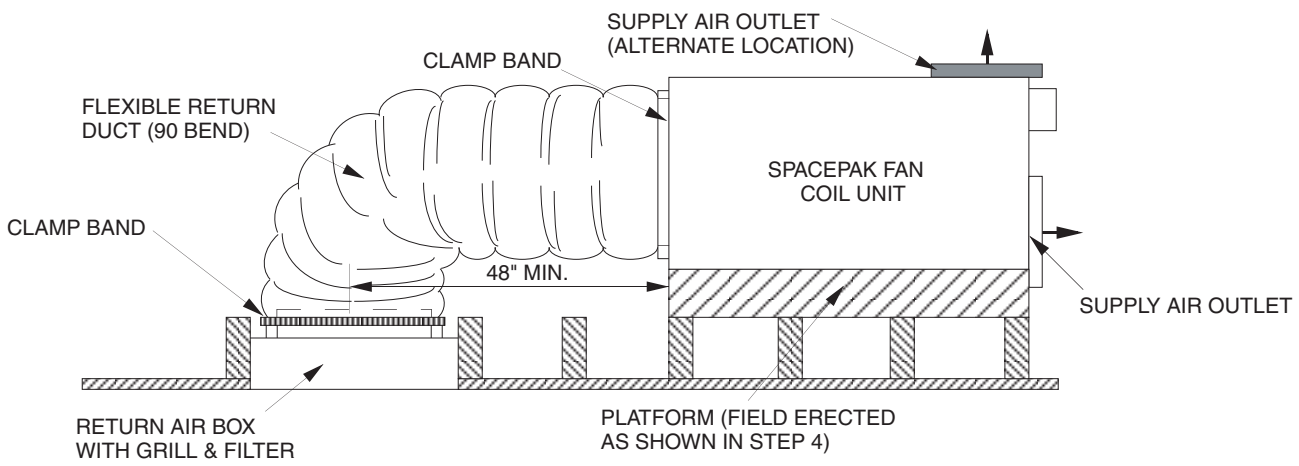

FIGURE 2.4: TYPICAL UNIT INSTALLATION

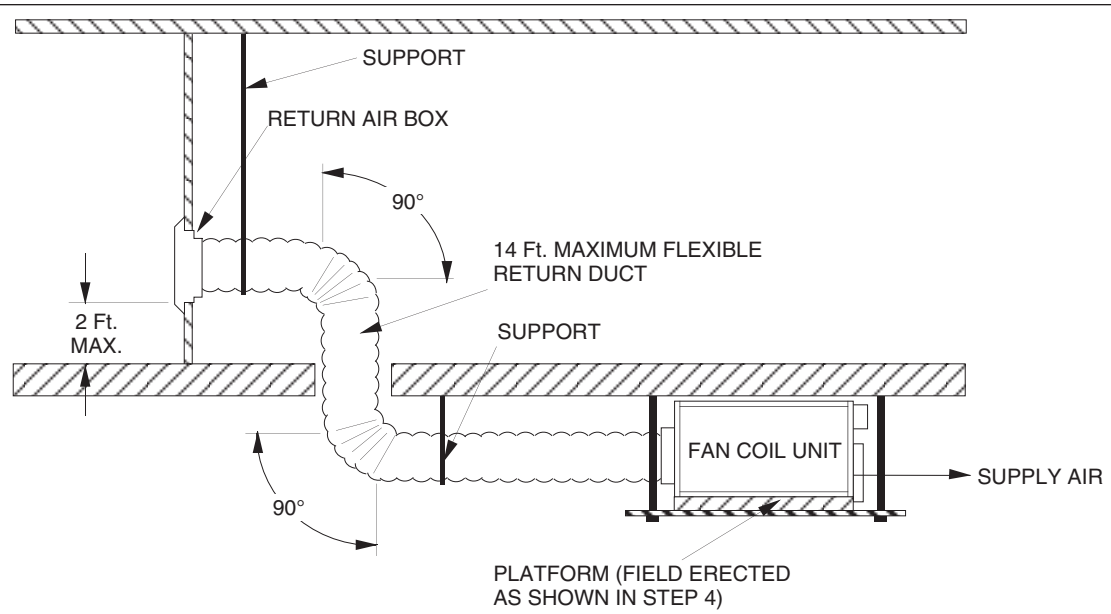

FIGURE 2.5: HORIZONTAL AIR FLOW UNIT INSTALLATION

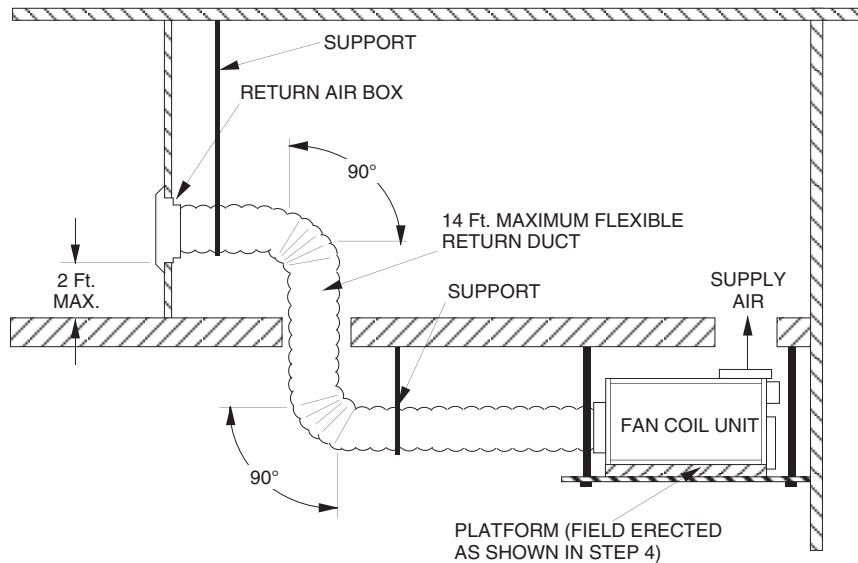

FIGURE 2.6: VERTICAL AIR FLOW UNIT INSTALLATION

STEP 2: CUTTING RETURN AIR OPENING

Select exact location for return air box. Avoid installing box in dining room, living room, kitchen, etc., unless return air duct can be installed with at least two 90° bends (accomplished by splicing two return air ducts together.)

For attic installations to raise fan coil unit up through opening, cut return air opening 14-1/2" wide by 27" long for the ESP-2430G, 14-1/2" wide by 31-1/2" long for the ESP-3642G* and 14-1/2" wide by 36-1/2" long for the ESP-4860G. These openings will accommodate the return air box with sufficient frame lip to cover the opening (see Figure 2.7).

***NOTICE: The return air panel must be removed from the ESP-3642G unit to fit through hole cut out.**

If joists are on 16" centers, the 14-1/2" width of the return air box should fit between successive joists. Where joists run in the opposite direction, or to properly center the return, it may be necessary to cut joists and install headers.

For all wall return applications, cut the return air opening to accommodate the return air box according to the same dimensions. Remember, location of opening must allow for a 90° bend in the return air duct.

Check the opening for proper fit of the return air box. Do not install the return air box until the installation of the entire SpacePak system is completed, if you want to fit materials up through this hole.

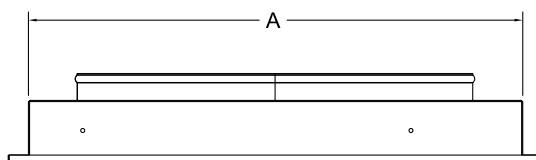

Measure return air box dimension "A" to determine length of opening.
Height = 14-5/16"

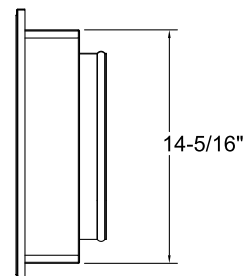
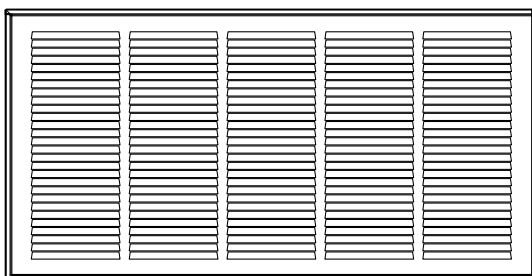

FIGURE 2.7: RETURN AIR BOX FRAME DIMENSIONS

DWG0045

STEP 3: ATTACHING SUPPLY AIR PLENUM ADAPTOR

NOTICE: If unit is to be located in the attic and installed through ceiling joists, attach supply plenum adaptor in attic.

A. HORIZONTAL DISCHARGE:

Refer to Figure 2.3 and duct installation instructions supplied with fan coil unit.

B. TO CONVERT TO VERTICAL DISCHARGE:

Refer to Figure 2.8 & 2.9

Tools required: 1/4", 5/16", 3/8", 7/16" box wrenches and nut drivers, 5/32" Allen wrench, utility knife & Malco S-3 offset hand seamer (3" duct-bill pliers).

Field supplied: latex caulk, UL classified duct liner adhesive (or equivalent).

NOTICE: An Electric Heat Module cannot be installed after unit has been field converted to vertical supply air discharge (due to resulting blower housing obstruction).

Refer to Figure 2.8 for Steps 2 to 8a.

1. Place unit horizontally on a flat raised surface.
2. Remove all side access panels, return air panel and cover plate from top panel.
3. Remove top panel by removing top/center screw from electric control box and panel screws.
4. Remove (4) screws securing front panel flange to blower housing.
5. Remove sealant around discharge opening.
6. Remove (3) remaining screws from electrical control box. Set box aside.
7. Remove (2) screws attaching blower housing to motor support channel flange.
- 8a. Remove (6) screws attaching motor mounting base to motor support channel.
- Refer to Figure 2.9 for Steps 8b to 18.
- 8b. Shift motor mounting base (and blower housing) backward coil to second set of mounting lugs on motor support channel. Rotate blower housing up 90°. Reattach base with screws.
9. Cut insulation from discharge air location on top panel (opening dimensions shown in Figure 2.3). Insert cut piece into opening. Apply adhesive per manufacturer's instructions. Attach cover plate to front of unit.
10. Bend both flanges 90° into cabinet using 3" duct-bill pliers. Pliers should engage full jaw depth (1-1/4") and be centered on flange.
11. Insert blower housing into top panel. Reattach panel to unit.
12. Align hole in blower housing with lower slot in motor support channel flange. Attach housing to flange with (1) previously removed screw.
13. Align (4) holes in top panel flange with holes in blower housing. Attach with removed screws.
14. Assure blower wheel is centered in inlet and discharge of blower housing. If required, adjust by loosening (4) bolts securing motor. Shift motor and refasten. For blower wheel adjustments, loosen set screw (not shown), shift wheel and refasten.
15. Apply latex caulk to seal between blower housing and top panel.
16. Reinstall electrical control box.
17. Place supply air plenum adaptor over discharge opening. Align holes in plenum adaptor, gasket and top panel. Secure with screws provided with adaptor.
- NOTICE: Check that all inside cabinet surfaces are covered with insulation, add insulation if required. An uninsulated panel will "sweat" and condensate will form on the cabinet.**
18. Replace all panels and screws.

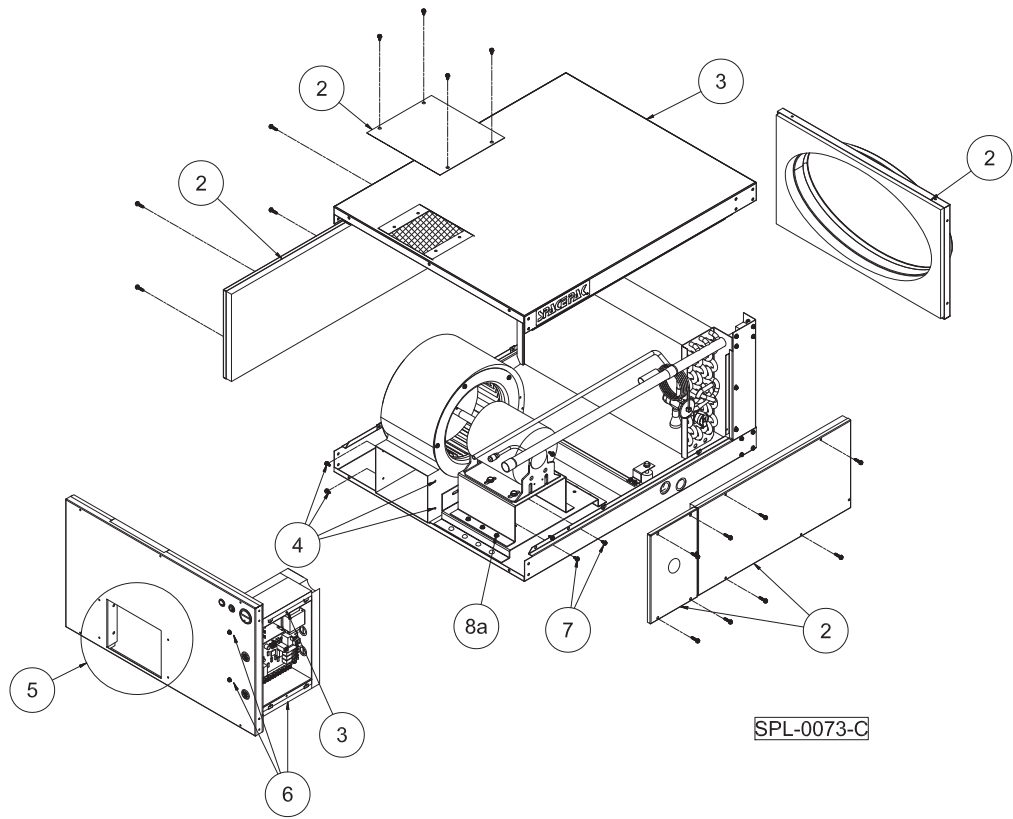

FIGURE 2.8

SPL-0073-C

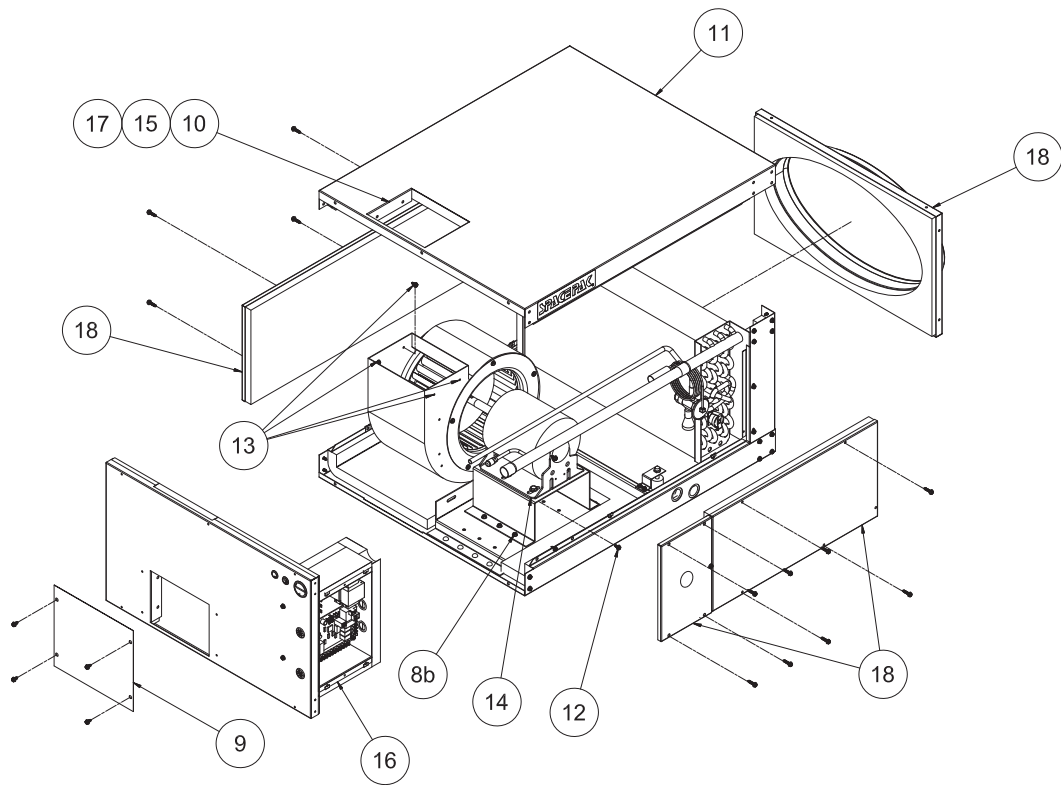

FIGURE 2.9

SPL-0074-C

STEP 4: SETTING THE UNIT

Construct a platform for the fan coil unit, as shown in Figure 2.10. The platform can be constructed of 2 X 4 (minimum), 2 X 6, 2 X 8 and 2 X 10 lumber, as necessary to achieve proper pitch of 1/4" per foot for the condensate drain line. Figure 2.11 shows the approximate normal allowable run of condensate piping as a function of the framing lumber used for platform construction. The platform covering should be 1/2" plywood minimum.

Attach vibration isolation pads (supplied inside fan coil unit) to platform covering as shown in Fig. 2.10.

Secure the platform to the joist or floor, depending on location selected for the fan coil unit. Make sure platform is level.

For locations where the fan coil unit will be suspended, suspend platform from overhead by 1/4" threaded rods.

NOTICE: Allow room on sides for servicing.

LUMBER SIZE	2 X 4	2 X 6	2 X 8	2 X 10
MAXIMUM HORIZONTAL	8'	16'	24'	32'

FIGURE 2.11: CONDENSATE PIPING RUNS

For installations with a return air box and return air duct, set fan coil unit on the platform with the elliptical opening facing in the direction of the return air box. **DO NOT** let the supply air plenum adaptor support the weight of the unit.

Do not secure the unit to the platform, as the weight of the unit will hold it in position.

STEP 5: CONNECTING REFRIGERANT LINES

Connect refrigerant lines from the outdoor condensing unit to the fan coil unit in accordance with its manufacturer's sizing recommendations for the length of the piping run. Proper line sizing is critical to the operation of the system. Always use proper brazing procedures. A trickle flow (2PSI) of dry nitrogen to avoid scale or blockage in the piping system is recommended while brazing. SpacePak also recommends installing a sight glass on the liquid line outside of the unit as an aid for accurately charging the system.

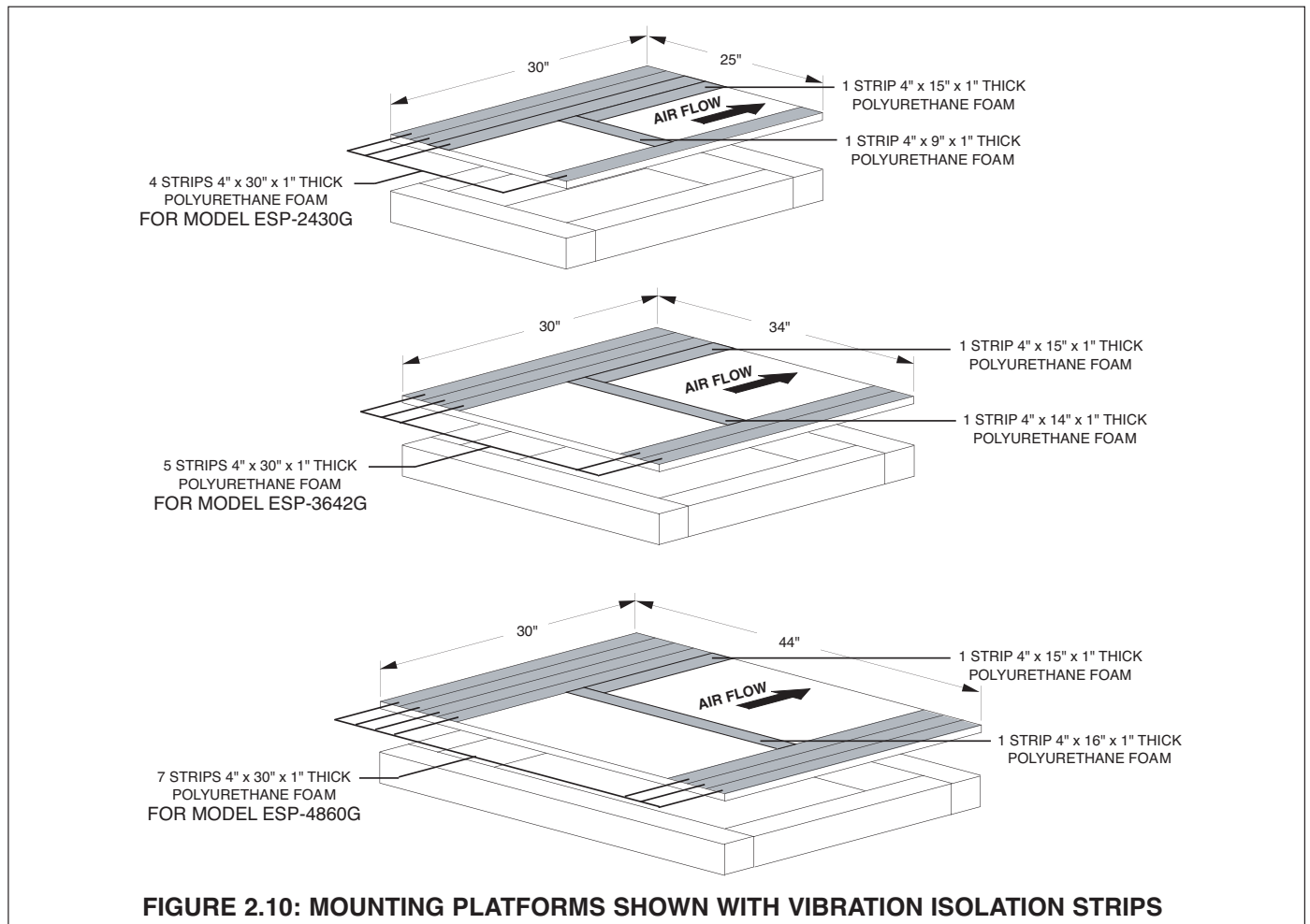

FIGURE 2.10: MOUNTING PLATFORMS SHOWN WITH VIBRATION ISOLATION STRIPS

STEP 6: INSTALLING THE CONDENSATE TRAP & LINE

NOTICE: It is a requirement of the International Mechanical Code (307.2.3) to install a secondary drain or an auxiliary drain pan where damage to any building components will occur as a result of overflow from the equipment drain pan or stoppage in the condensate drain piping from a cooling or an evaporator coil. Follow local code requirements.

Refer to Fig. 2.2 for primary and secondary condensate drain locations. Components for the PVC condensate trap are provided in a separate bag with fan coil unit (see Fig. 2.12) and should be cemented together with PVC pipe cement.

CAUTION Do not use substitute trap. Do not cut off or alter trap components.

Screw male adapter (see Fig. 2.12) into unit's primary condensate drain connection. Assemble and cement remaining components together. Then cement assembly to male adapter. The 45° elbow provides an offset from beneath unit suction line for access to clean-out plug.

Run a condensate line from the trap to a suitable drain that's in accordance with local codes. Make sure the line is pitched 1/4" per foot.

NOTICE: The secondary drain connection requires field supplied components to complete installation. Follow local code requirements.

NOTICE: Never connect condensate line to a closed drain system.

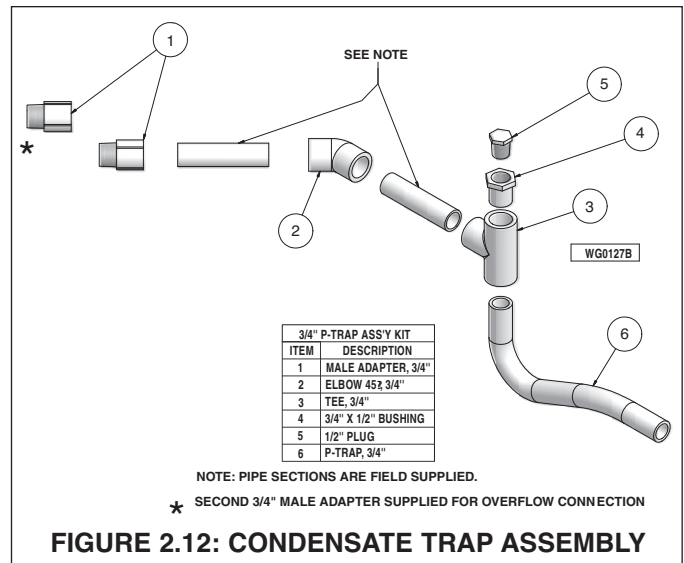

FIGURE 2.12: CONDENSATE TRAP ASSEMBLY

STEP 7: WIRING THE UNIT

WARNING Turn off electrical power supply before servicing. Contact with live electric components can cause shock or death.

All electrical and control wiring must be installed in accordance with the codes listed in Section 1 of this manual. Wiring diagram is provided in Figure 2.13. A separate 208-230/60/1 power supply is recommended for the unit. Use standard 15-amp fuse and 16-gauge wire from power supply to unit.

Connect power supply to Terminals L1 and L2 on the high voltage terminal block. Connect a ground wire to the equipment ground terminal located next to the high voltage terminal block.

STEP 8: INSTALLING AIR DISTRIBUTION COMPONENTS

All plenum duct and supply tubing runs as well as room terminator locations must be in accordance with air distribution system requirements listed in Section 1 of this manual. Where taping of joints is required, UL181 approved tape is required.

The low voltage transformer in the unit has a 208 volt tap in the primary winding (color coded RED). If unit is to be operated with 208 volt electrical service, remove the 230 volt ORANGE lead from the L2 terminal and connect the 208 volt RED lead to the L2 terminal. Be sure to insulate the end of the unused ORANGE lead.

Locate the room thermostat on a wall near the return air box, between 40" to 48" from the floor. Connect the low-voltage thermostat wiring from the room thermostat to the low voltage control block in the unit.

Connect low voltage from air handler to condensing unit as shown in figure 2.13.

Set DIP switches according to application. See page 14, SpacePak G Series Control DIP switch settings.

Plenum Duct Installation

All tees, elbows and branch runs must be a minimum of 24" from the fan coil unit or any other tee, elbow or branch run. Keep all tees and elbows to a minimum to keep system pressure drop on larger layouts to a minimum.

NOTICE: Refer to duct installation instructions supplied with fan coil unit or follow manufacturers instructions supplied with other duct system types.

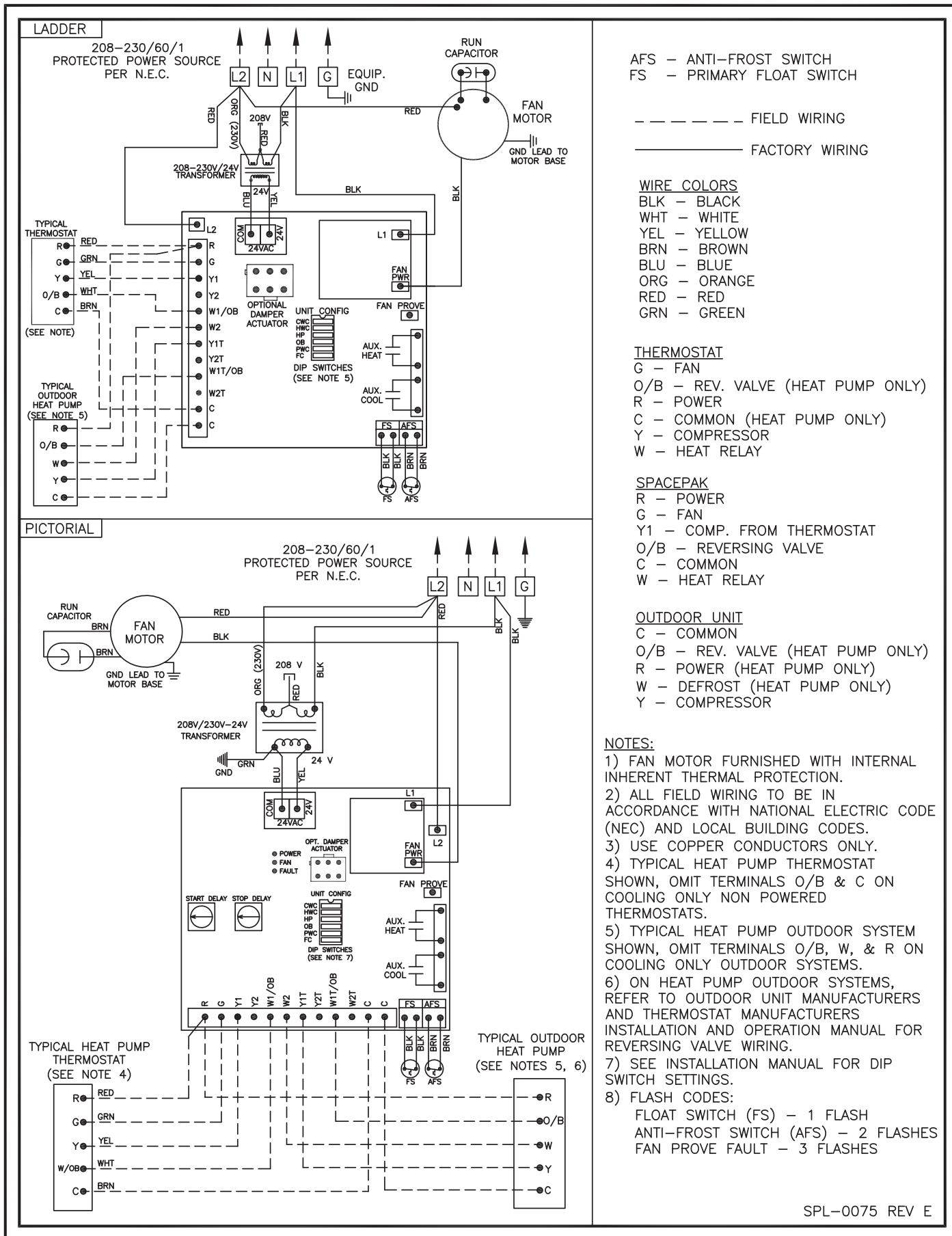
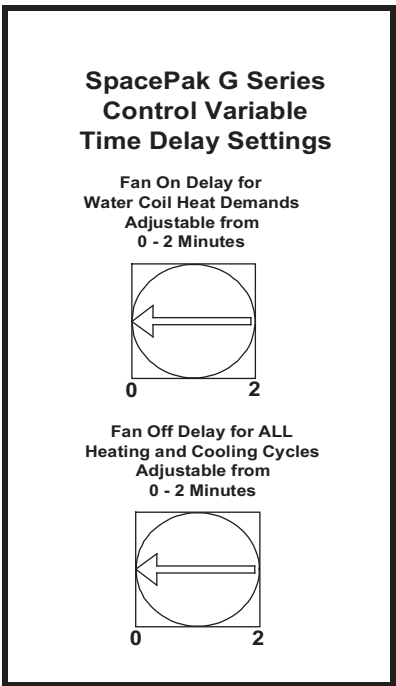
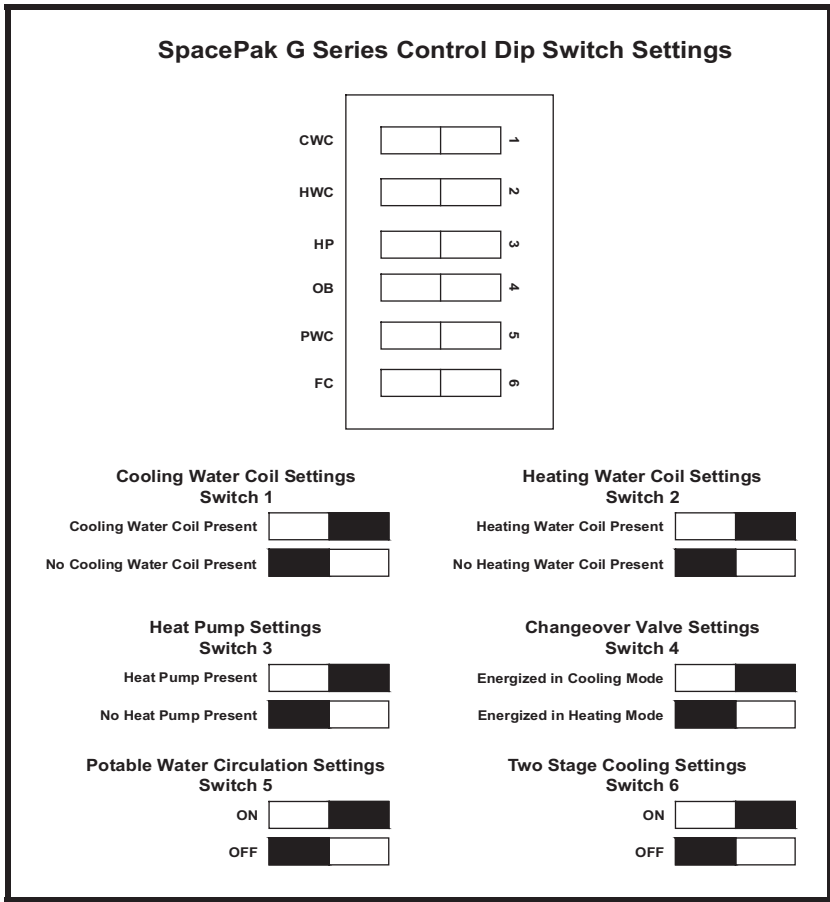

FIGURE 2.13: WIRING DIAGRAM



SpacePak G Series Control Indicator LEDs

Power Indicator

The Power indicator will blink to indicate that the control is operational.

Fan Prove Indicator

The Fan Prove indicator will illuminate when there is power to the fan and the optional damper is in the open position.

Note: The Fan Prove Terminal will also energize with 24VAC when the above conditions are met.

Fault Indicator

Fault Flash Codes:

Float Switch	1 Flash
Anti-Frost Switch	2 Flashes
Fan Prove Fault	3 Flashes

Note: All Flash Codes are latched until power is cycled, even if the fault is cleared. The Float Switch requires power to be cycled to resume operation.

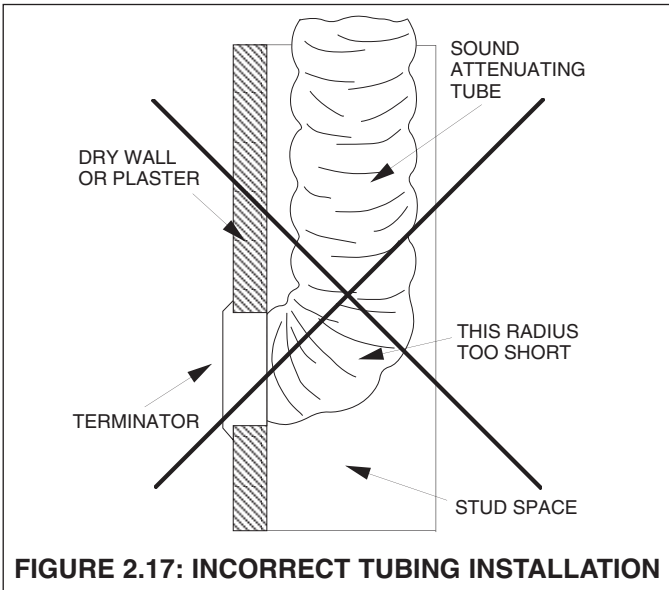

Room Terminator & Sound Attenuating Tubing Installation

Room terminators and pre-assembled sound attenuating tubes are provided in the Installation Kits.

NOTICE: Do not install terminators in a wall in which a sharp bend in the sound attenuating tube is required (see Figure 2.17). The result would be unacceptable noise.

OPTION: Using a SpacePak Kwik Connect Wall Elbow (Model Number: AC-KCWE) addresses this condition (see Figure 2.18).

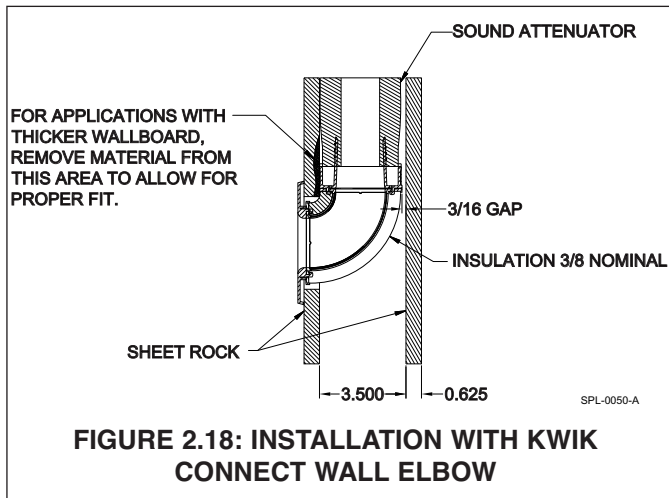

In marking location for room terminator (see Figure 2.19), the center of the terminator should be approximately 5" from the wall or, when installed in the corner of a room 5" from both walls.

After marking location, drill a 1/8" diameter hole for outlet. Verify there is at least 2" for tubing assembly clearance all around this hole by visual inspection or inserting a bent piece of wire to feel for obstructions. Adjust direction of hole as needed, to gain this 2" clearance. After all clearances have been checked, take a 4" diameter rotary-type hole saw and cut a hole, using the 1/8" diameter hole as a pilot.

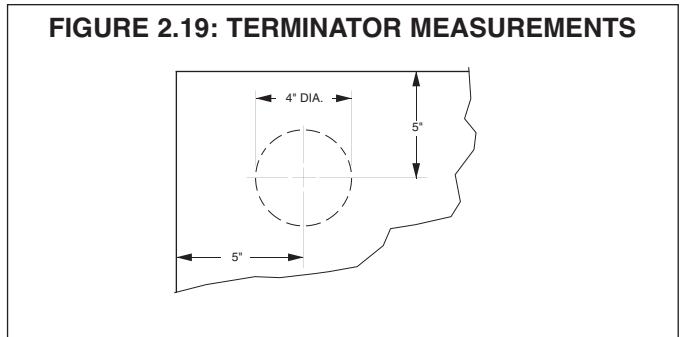

Assemble spring clips to terminator plate with screws provided in installation kit. Tighten clips until they are close to the thickness of the material they are being mounted to.

Assemble the room terminator to the sound attenuating tubing by simply fitting the two pieces together and twisting until tight (see Figure 2.20). If the terminator is to be used in a floor location, then field fabricate a small screen (1-1/2" square; 1/4 X 1/4 20-gauge galvanized wire screen) and place screen over opening on the back of the terminator prior to twisting on the kwik-connect (on the sound attenuating tube).

NOTICE: Do not shorten sound attenuating tube length. The result would be unacceptable noise.

Push the free end of the sound attenuating tube through the 4" hole until the two toggle springs on the room terminator snap into place.

Center the two spring clips on a line parallel to the direction of the tubing routing from the room terminator (see Figure 2.20). This is important since the weight of the tubing will have a tendency to cause a part of the terminator to pull away from the ceiling if the clips and tubing do not run parallel.

Then tighten the screws (attached to the terminator) until the terminator is snug against the ceiling or floor. **Do not overtighten.** For installations with floors or ceilings which are thicker than normal, longer toggle screws or special mounting plates may be required.

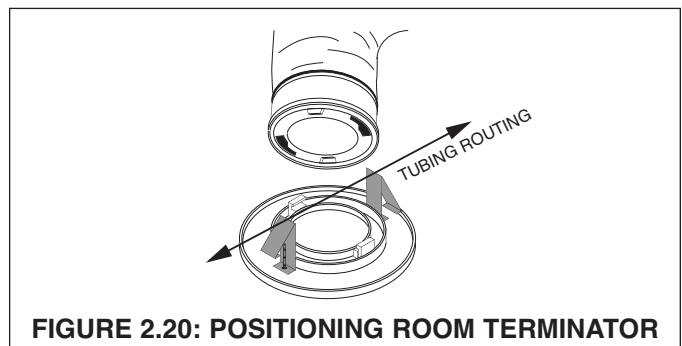

Supply Tubing Installation

Kwik-connects and balancing orifices are provided in the Installation Kits. Plenum take-offs, gaskets and fasteners are supplied in the separate plenum take-off kit.

Avoid sharp bends in the supply tubing (as well as the sound attenuating tubing). The minimum radius bend is 4" (see Figure 2.21); however, wherever possible, hold to a larger radius.

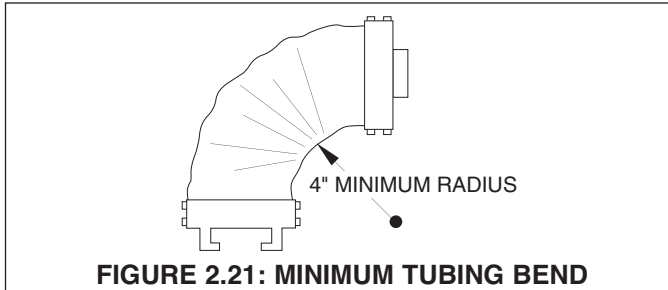

FIGURE 2.21: MINIMUM TUBING BEND

At the plenum, all supply tubing connections must be a minimum of 18" from any plenum tee, plenum elbow or the fan coil unit.

Individual supply tubing runs must be a minimum of 6-feet, even if the distance between the sound attenuating tubing and plenum is less than 6 feet.

Supply tubing comes in 100-foot sections (R8 tubing comes in 75-foot sections) and may be cut to length with a knife or fine tooth hacksaw.

For each supply tubing run, estimate and cut the length of tubing that will be needed between the plenum and sound attenuating tube. At the open end of the supply tubing a kwik-connect will be installed (see Figure 2.22). First, push back the cover and the insulation exposing approximately 4" of the inner core. Fold in any tails or frays that may be present after cutting the supply tubing. Second, hand compress the corrugations until they are densely compacted 1-1/2" to 2" from the open end of the supply tube. Third, thread kwik-connect into the inner core until snug. Fourth, pull the insulation and cover forward and tuck it into the deep groove on the back side of the kwik-connect. Fifth, wrap the connection securely with UL181 approved tape.

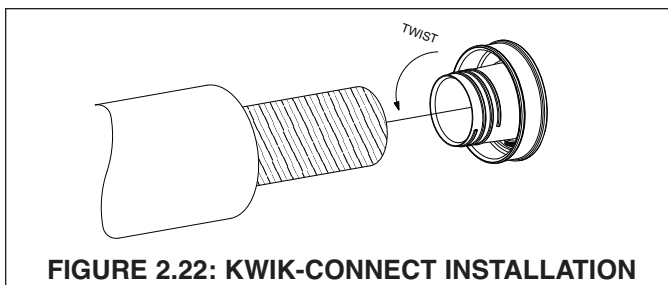

FIGURE 2.22: KWIK-CONNECT INSTALLATION

When finished, simply twist together (see Figure 2.23) the kwik-connect on the sound attenuating tube, and wrap the connection securely with tape.

After attaching the supply tubing to the sound attenuating tube, bring the open end of the tube to the plenum.

To cut a hole in the plenum, refer to duct installation instructions supplied with fan coil unit. Sheet metal duct requires a 2-1/16" hole.

Remove the hole cut-out from the plenum. Make sure there is no "flap" left inside plenum that could block hole during operation.

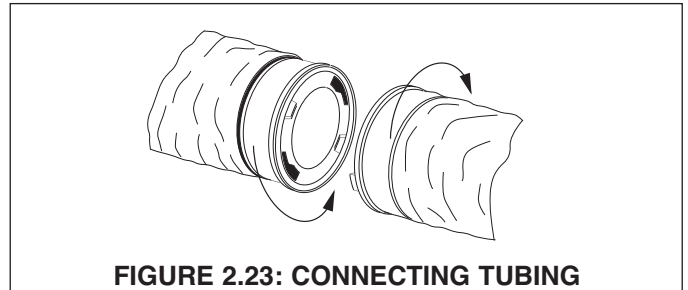

FIGURE 2.23: CONNECTING TUBING

Place the plenum take-off gasket on the back side of the plenum take-off and insert the assembly into the hole in the plenum (see Figure 2.25).

NOTICE: Gasket must be installed to seal plenum take-off to prevent air leakage.

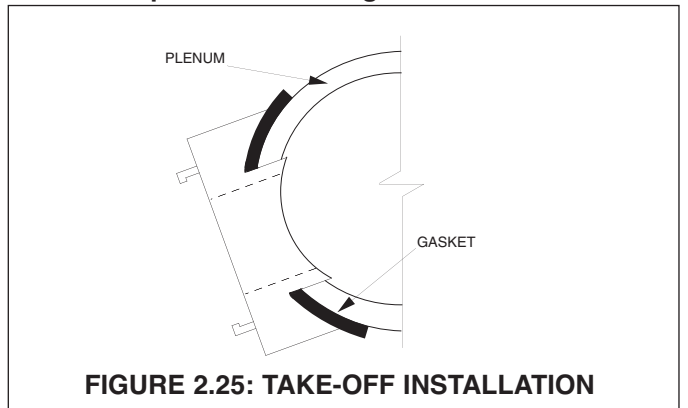
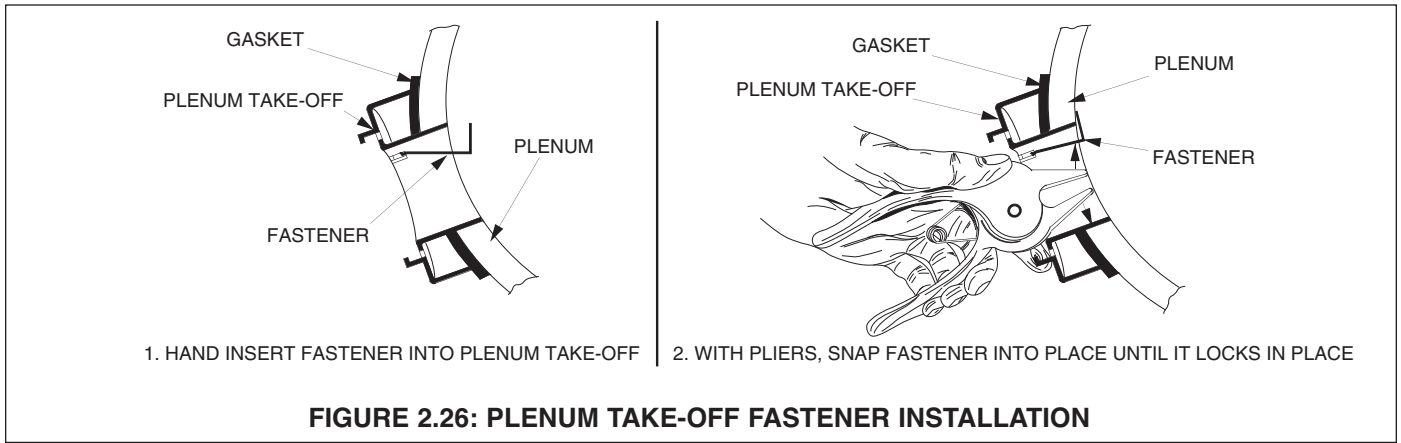

FIGURE 2.25: TAKE-OFF INSTALLATION

Position the plenum take-off to match the curvature of the plenum duct. Hand insert the four plenum take off fasteners one at a time such that each clip reaches the interior of the duct. Using the SpacePak pliers, snap the fasteners into place until they lock in place (see Figure 2.26).

NOTICE: All four fasteners must be installed to assure air tight fitting between plenum take-off and plenum.



In accordance with your calculations as to requirements for balancing orifices, mount the orifice in the outlet of the plenum take-off (see Figure 2.27), prior to attaching the supply tubing.

Next, install a kwik-connect in the open end of the supply tubing, using the same procedures as before, and twist together kwik-connects on supply tubing and plenum take-off. Wrap connection securely with tape.

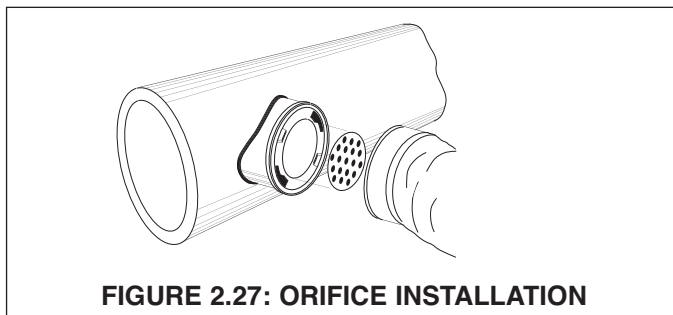

Return Air Box & Duct Installation

Remove the return air grill from the return air box and remove the air filter from the return air grill.

Insert the return box from below for ceiling installation (or from the front for wall installations) and fasten with four screws through holes provided on the long side of the box. (see Figure 2.28).

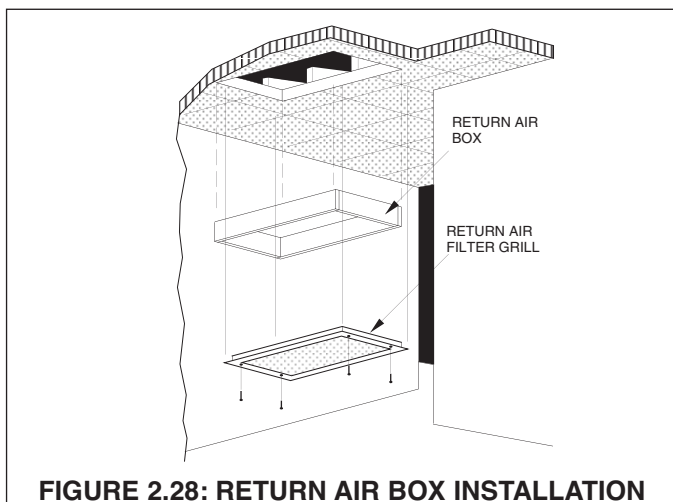

Remove the grill and the filter from the grill frame. Insert the frame into the box and mount in place with the screws provided through a hole at each corner of the frame. Finally, place the air filter into the frame and replace the grill. Turn the latches a quarter turn to lock the grill in place.

Slide a clamp band (provided with return air box) over one end of the return air duct. Place that end over the elliptical flange on the fan coil unit (see Figure 2.29). Move the clamp over the flange and tighten so the clamp holds the return air duct securely to the flange. Follow the same procedures to attach the return air duct to the return air box (see Figure 2.29).

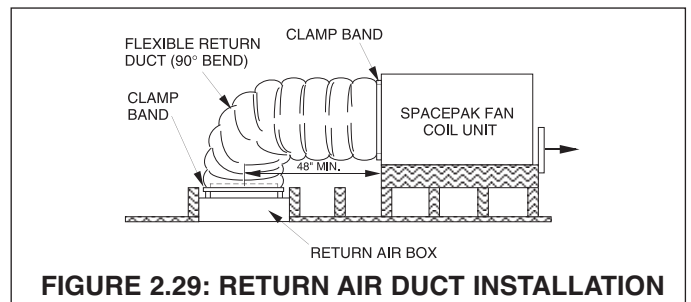

Winter Supply Shut-Off Installation

Simply insert winter supply shut-offs into the room terminator openings (see Figure 2.30). Wrap the return air filter in a plastic bag and reinstall it to block the return air opening. Winter supply shut-offs prevent moisture from collecting in ductwork during winter months. Be sure to remove the plastic bag and all winter supply shut-offs before operating the system.

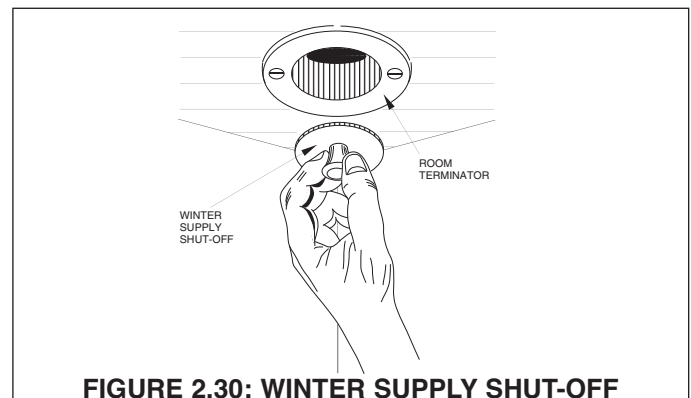

SECTION 3: START-UP & OPERATION

SEQUENCE OF OPERATION

When power is turned on and thermostat fan switch is set to ON and the cooling indicator is set to OFF, the indoor fan motor is energized in approximately 2 minutes. The outdoor unit is off.

When power is turned on and thermostat fan switch is set to ON or AUTO and the cooling indicator to COOL the indoor and outdoor units will start.

AUTO position on the thermostat will stop and start your system when the temperature setting is satisfied. The ON position on the thermostat will stop the outdoor unit only when the temperature setting is satisfied and the indoor unit will continue to run, recirculating indoor air.

The fan coil unit is equipped with a protective device called an anti-frost control which will automatically stop the outdoor unit (while the indoor unit continues to run) if ice accumulates on the indoor unit evaporator coil causing abnormal operating conditions. When the accumulated ice has melted, the anti-frost control will restart the outdoor unit.

The fan coil unit is equipped with primary float switch, and the system will automatically shut down if the drain pan is full of water (condensate) and not draining. The system requires service.

PRIOR TO START-UP

1. Check all electrical connections for tightness.
2. Check air filter has been installed in return air box or filter box.
3. Remove all winter supply shut-offs and store them in a safe place.

SYSTEM START-UP & ADJUSTMENTS

1. Place thermostat fan switch in ON position and cooling indicator in OFF position. In about 2 minutes, indoor unit blower will start.
2. Check blower operation for excess noise or vibration.
3. Check entire distribution system for leakage and apply additional tape where necessary.

4. Check that system static pressure is within acceptable limits (minimum 1.2" W.C. - maximum 1.5" W.C.). Static readings must be taken in the plenum a minimum of 18" from the fan coil unit, plenum tees or elbows but before any supply run.
 - a. If greater than 1.5" W.C. add additional supply runs.
 - b. If less than 1.2" W.C. check the return air filter is clean and return duct is not collapsed or kinked.
 - c. Check supply air plenum for leaks.
 - d. If more supply runs than recommended are used, check that balancing orifices are in place.
5. Check that blower motor amp draw compares with fan coil unit rating plate. Amp draw shown on plate is the FLA of motor (not the actual running amps) and will vary with the pressure and voltage.
6. Place the thermostat cooling indicator in COOL position, which will start the outdoor unit. Let the system run at least 30 minutes to stabilize operating conditions.
7. For outdoor unit start-up, follow manufacturer's instructions.
8. Check that temperature drop across evaporator coil in the indoor unit is between 20°F to 28°F.

NOTICE: Do not introduce refrigerant liquid to system through suction port. Liquid in the suction line may damage the compressor.

NOTICE: Before adding refrigerant to system verify Item #4 in "System Start-up & Adjustment" section has been performed.

9. Verify that system refrigerant is correct by measuring subcooling at liquid service port. Subcooling should be 10°F to 13°F.
10. Check the super heat leaving the evaporator coil against the corresponding suction pressure from the schrader fitting at the fan coil unit. Superheat value should be between 9°F and 12°F.
11. If a sight glass has been installed on the liquid line at the air handler check for the presence of flashing. If flashing is occurring, check and adjust subcooling by adding refrigerant.

CHARGING COOLING ONLY SYSTEMS

After start-up, allow the system to operate for approximately 30 minutes in order to establish stable operating conditions. Check that the temperature drop across the evaporator coil is 20°F to 30°F. Do not attempt to adjust the charge at ambient temperatures below 65°F.

1. Check refrigerant charge by measuring liquid subcooling. Subcooling should be approximately 10°F to 13°F. If a sight glass has been installed on the liquid line at the fan coil unit check for the presence of flashing.
2. If the subcooling is below 10°F, add refrigerant gas to the suction line service port. Watch pressure gauge and thermometer for correct subcooling. It should be approximately 10°F to 13°F.

3. If subcooling is too high, slowly bleed refrigerant from suction line service port into an appropriate refrigerant recovery device. Watch pressure gauge and thermometer for correct subcooling (10°F to 13°F).

▲ CAUTION Releasing refrigerant gas into the atmosphere is a criminal offense.

FACTORS AFFECTING THE BALANCE OF THE SYSTEM

- A. Room Terminators (Outlets): Based on the equipment selected, determine the recommended number of fully open outlets from Figure 3.1.

FIGURE 3.1

NOMINAL TONNAGE	MINIMUM RECOMMENDED NUMBER OF FULLY OPEN OUTLETS		
	MODEL	A	B
2	ESP-2430G	12	14
2-1/2	ESP-2430G	15	18
3	ESP-3642G	18	21
3-1/2	ESP-3642G	21	25
4	ESP-4860G	26	28
5	ESP-4860G	30	35

1. The minimum or recommended number of outlets means fully open outlets. Any outlet having an orifice would be only a percentage of an outlet.
2. For systems with average supply tubing lengths of 15 feet or less, use column A. For systems with supply tubing lengths greater than 15 feet, use column B.

NOTICE: The number of outlets and average length of the supply tubing has a significant effect on the overall system performance. It is highly recommended that the adjustment factors outlined in the SpacePak Application Manual are accounted for prior to any installation.

- B. Orifice Combinations: Should orifices be required to balance the system (installed at plenum take-off), refer to the combinations listed in Figure 3.2.

FIGURE 3.2

DESIRED NUMBER OF TERMINALS*	TERMINAL - ORIFICE COMBINATION
.5	(1) .5
.65	(1) .35
.85	(1) .15
1.00	(1)
1.15	(1) .5 + (1) .35
1.30	(2) .35
1.50	(1) .35 + (1) .15 or (1) + (1) .5 or (3) .5
1.65	(1) + (1) .35 or (2) .5 + (1) .35
1.70	(2) .15
1.80	(2) .35 + (1) .5
1.85	(1) + (1) .15
1.95	(3) .35
2.00	(2)

*For a room with more than two (2) terminals, combinations of the above may be used to achieve the desired fractional number.

- C. Supply Tubing Length: An outlet with a supply tubing length of 15 feet is considered one, fully opened outlet. For other lengths refer to Figure 3.3 for adjustment factors.

FIGURE 3.3

2" SUPPLY TUBING LENGTH ADJUSTMENT FACTOR CHART								
RUN	6'	8'	10'	12'	15'	20'	25'	30'
FACTOR	.85	.88	.90	.94	1.0	1.1	1.25	1.50

SECTION 4: MAINTENANCE

The SpacePak system has been designed to provide years of trouble-free performance in normal installations. Examination by the homeowner at the beginning of each cooling season, and in mid-season should assure continued, good performance. In addition, the system should be examined by a qualified service professional at least once every year.

BEFORE EACH COOLING SEASON

1. Check and clean air filter. The air filter is permanent type. Remove and clean thoroughly with soap solution and water.

▲ WARNING Turn off electrical power supply before servicing. Contact with live electric components can cause shock or death.

2. Check fan coil unit. Turn off unit power disconnect switch and remove service access panels.
 - a. Inspect evaporator coil and blower wheel for build-up of dust and dirt. Clean with solvent and/ or water as necessary.
 - b. Replace service access panels and turn on unit power disconnect switch.

3. Check that unit condensate drain is clear and free running, and plug is in cleanout.
4. For outdoor condensing unit, follow manufacturer's maintenance instructions.
5. Follow "System Start-Up & Adjustments" procedures in Section 3 of this manual.

IF SYSTEM FAILS TO OPERATE

1. Check that thermostat switch is set for proper mode of operation and is set below room temperature.
2. Check that outdoor unit is operating.
 - a. Confirm that compressor and fan are operating properly.
 - b. Confirm voltages to outdoor unit.

IF FAN AND COMPRESSOR AT OUTDOOR UNIT ARE NOT RUNNING

1. Check Fault Indicator. See Flash Codes, page 14. Float switch fault will stop fan and compressor.
2. Check for tripped circuit breaker or blown fuse at either the main fuse box or at unit disconnect box on or near the condensing unit. Replace blown fuse with same size and type.
3. Review Troubleshooting Guide beginning on page 21 of this manual.

TROUBLESHOOTING GUIDE

CONDITION: ESP-G & CONDENSING UNITS RUN, BUT COOLING INSUFFICIENT

POSSIBLE CAUSE	VERIFICATION	SOLUTION
Low Suction Pressure	Check blower motor as described on page 25 in this manual.	If defective, replace motor.
	Check that filter in return air box is clean.	Clean air filter.
	Check system refrigerant charge.	Charge to proper subcooling according to manufacturer's instructions.
	Check for dirty evaporator coil.	Clean evaporator coil.
High Suction Pressure	Check for air bubbles in system refrigerant.	Charge to proper subcooling according to condensing unit manufacturer's instructions. Install sight glass near indoor unit and monitor.
	Check calculated heat gain to be sure that equipment is sized properly.	Take necessary action.
	Check for obstructions near condensing unit which could cause recirculation of air.	Remove obstructions.
Low Head Pressure	Check system refrigerant charge.	Charge to proper subcooling according to condensing unit manufacturer's instructions.
	Check calculated heat gain to be sure that equipment is sized properly.	Take necessary action.
High Head Pressure	Check condenser fan motor according to condensing unit manufacturer's instructions.	If defective, replace fan motor.
	Check for dirty condensing unit coil.	Clean condensing unit coil.
	Check system refrigerant charge.	Charge to proper subcooling according to condensing unit manufacturer's instructions.
	Check for dirty evaporator coil.	Clean evaporator coil.
	Check for obstructions near condensing unit which could cause recirculation of air.	Remove obstructions.
	Check for restricted liquid lines.	Remove restrictions and kinks from lines.
Distribution System Air Leaks	Check all joints in air distribution system.	Make sure all joints are air tight. Verify static pressure as described on page 25 in this manual.

CONDITION: ESP-G UNIT & CONDENSING UNIT WILL NOT START

POSSIBLE CAUSE	VERIFICATION	SOLUTION
Thermostat Not Level	Check level of thermostat	If necessary, level thermostat.
Defective Thermostat	With volt meter, check resistance of thermostat contacts.	If resistance, thermostat is O.K. If no resistance, replace thermostat.
Loose Low Voltage Wiring	Check all wiring connections for tightness.	Tighten all loose connections.
Defective Low Voltage Transformer	Check transformer as described on page 25 in this manual.	If defective, replace transformer.
Inadequate Electrical Service	Check electrical service against minimum requirements.	Replace electrical service with adequately sized service.
Flash Code - 1 Flash (Float Switch)	Check drain pan and condensate trap.	Clean condensate trap.

CONDITION: ESP-G UNIT WILL NOT START, BUT CONDENSING UNIT RUNS

POSSIBLE CAUSE	VERIFICATION	SOLUTION
Shorted Or Broken Wiring	Check wiring.	If necessary, repair or replace wiring.
Loose Low or High Voltage Wiring	Check all wiring connections for tightness.	Tighten all loose connections.
Defective Blower Motor	Check motor as described on page 25 in this manual.	If defective, replace motor.

CONDITION: ESP-G UNIT RUNS, BUT CONDENSING UNIT WILL NOT START

POSSIBLE CAUSE	VERIFICATION	SOLUTION
Defective Thermostat	With volt meter, check resistance of thermostat contacts.	If resistance, thermostat is O.K. If no resistance, replace thermostat.
Loose Low Or High Voltage Wiring	Check all wiring connections for tightness.	Tighten all loose connections.
Flash Code - 2 Flashes (Anti-Frost Switch)	With volt meter, check for 24v at terminal "AFS".	If no voltage, check coil for ice. If ice is present, check air filter, return air duct & blower motor for air flow. If no ice on coil, check anti-frost switch for continuity. If no continuity, replace switch. If 24v, switches are O.K.
Shorted Or Broken Wiring	Check wiring.	If necessary, repair or replace wiring.
Condensing Unit	Check according to manufacturer's instructions.	Repair or replace as directed by manufacturer.

CONDITION: ESP-G UNIT WILL NOT START, BUT CONDENSING UNIT CYCLES

POSSIBLE CAUSE	VERIFICATION	SOLUTION
Incorrect Low Voltage Connections	Check low voltage connections against wiring diagram.	Correct low voltage connections.
Loose Low Voltage Connections	Check all wiring connections for tightness.	Tighten all loose connections.
Defective Blower Motor	Check motor as described on page 25 in this manual.	If defective, replace motor.

CONDITION: ESP-G UNIT CYCLES, BUT CONDENSING UNIT RUNS

POSSIBLE CAUSE	VERIFICATION	SOLUTION
Blower Motor	Check motor as described on page 25 in this manual.	If defective, replace motor.
	Check motor amps and compare to nameplate ratings.	If excessive, motor may be overloaded. Check supply duct for breaks or leaks.

CONDITION: ESP-G UNIT RUNS, BUT CONDENSING UNIT CYCLES

POSSIBLE CAUSE	VERIFICATION	SOLUTION
Flash Code - 2 Flashes (Anti-Frost Switch)	With volt meter, check for 24v at terminal "AFS".	If no voltage, check coil for ice. If ice is present, check air filter, return air duct & blower motor for air flow. If no ice on coil, check anti-frost switch for continuity. If no continuity, replace switch. If 24v, switches are O.K.
Thermostat in Wrong Location	Check that thermostat is in vicinity of return air box.	If necessary, relocate thermostat.
Loose Low Or High Voltage Wiring	Check all wiring connections for tightness.	Tighten all loose connections.
Defective Blower Motor	Check motor as described on page 25 in this manual.	If defective, replace motor.
Condensing Unit	Check according to manufacturer's instructions.	Repair or replace as directed by manufacturer.

CONDITION: SWEATING AT ESP-G UNIT SUPPLY OUTLET

POSSIBLE CAUSE	VERIFICATION	SOLUTION
Air Leak At Supply Air Plenum Adaptor	Check taped joint at adaptor.	Tape joint properly.
Insulation at Outlet Not Installed	Check for insulation at outlet.	Install insulation.

CONDITION: EXCESSIVE NOISE AT TERMINATOR

POSSIBLE CAUSE	VERIFICATION	SOLUTION
High Supply Air Plenum Static Pressure	Check static pressure as described on page 25 in this manual.	Check for and add flow restrictors as necessary in supply runs.
		If necessary, add additional outlets.
Sound Attenuating Tube Not Installed	Check for installation of sound attenuating tube.	Where necessary, install sound attenuating tube.
Tight Radius In Sound Attenuating Tube Or In Supply Tubing	Check all tubing for tight radius.	Where necessary, correct radius.
Incorrect Supply Tubing Length	Check that all supply tubing runs are 9' minimum (includes 3 ft sound atten. tube).	Where necessary, correct supply tubing length.
Improperly Balanced System	Check that correct size orifices have been installed.	Properly orifice supply tubing runs.

CONDITION: EXCESSIVE NOISE AT RETURN AIR GRILL

POSSIBLE CAUSE	VERIFICATION	SOLUTION
Return Air Duct Not Installed Properly	Check for minimum 90° bend in return air duct.	Correct bend in return air duct to minimum 90°.
Dirty Return Air Filter	Remove and inspect.	Clean or replace air filter.

CONDITION: EXCESSIVE VIBRATION AT ESP-G UNIT

POSSIBLE CAUSE	VERIFICATION	SOLUTION
Noisy Blower Motor Assembly	Check blower motor assembly.	Tighten all fasteners.
	Check blower motor for bearing noise.	Replace motor.
	Check for loose or damaged blower wheel.	Tighten or replace blower wheel as necessary.

CHECKING ESP-G BLOWER MOTOR

1. With volt meter, check voltage at terminals L1 and L2 on line voltage terminal block. Voltage should be $\pm 10\%$ of ESP-G unit nameplate rating.
2. Disconnect power to the ESP-G unit at the disconnect switch.
3. Disconnect motor lead at terminal L2.
4. With an ohmmeter, check continuity between the disconnected motor lead and terminal "FAN PWR" on control panel.
 - a. If continuity, proceed to Step 5 below.
 - b. If no continuity, feel the motor to see if it is excessively warm which would indicate the internal over-load may be open. When motor has cooled, check again to make sure you did not get a false reading. If no continuity, motor is defective.
5. With an ohmmeter, check each motor lead to ground to be sure motor is not grounded.
 - a. If not grounded, proceed to Step 6 below.
 - b. If grounded, motor is defective.
6. Check capacitor, if capacitor is suspect, replace it with a capacitor of similar rating of motor operates normally, make a permanent capacitor replacement.
7. Reconnect all electrical leads, restore electrical services to the ESP-G unit, and place thermostat fan switch in the **ON** position.
8. With an ampmeter, check that amp draw compares with ESP-G unit rating plate. Amp draw shown on plate is the FLA of motor (not the actual running amps) and will vary with the pressure and voltage.

CHECKING ESP-G BLOWER

The ESP-G unit is equipped with a time-delayed blower. Wait two full minutes after turning on power for blower to start.

1. With a volt meter, check 24v across terminals R and C on the low voltage terminal block.
 - a. If read 24v, proceed to Step 2.
 - b. If no voltage, check low voltage transformer.

2. With a volt meter, check 24v across terminals G and C on the low voltage terminal block.
 - a. If read 24v, proceed to Step 3.
 - b. If no voltage, check thermostat fan circuit.

CHECK ESP-G LOW VOLTAGE TRANSFORMER

1. With volt meter, check for 230v across terminals L1 & L2 on the line voltage terminal block.
 - a. If reading 230v, proceed to Step 2.
 - b. If no voltage, check the power supply to the unit.
2. With volt meter, check for 24v across terminal R and terminal C on the low voltage terminal block.
 - a. If read 24v, transformer is O.K.
 - b. If no voltage, replace transformer.

CHECK EXTERNAL STATIC PRESSURE

You can use a U-tube manometer to check the external static pressure on the duct system.

1. Puncture a 1/4" hole in the plenum duct at least 18" from the fan coil unit.
2. Insert one manometer tube into the hole until the end of the tube is flush with the inside wall of the plenum duct.
3. System static pressure should be between 1.2" and 1.5" W.C.
 - a. If greater than 1.5" W.C. add additional supply runs.
 - b. If less than 1.2" W.C. , check:
 - I. Return air filter is clean
 - II. Return air duct has not been collapsed
 - III. Supply air plenum for leaks
 - IV. If more supply runs than recommended are used, check that flow restrictors (orifices) are in place.



Service / Troubleshooting FORM "1A"

Customer / Dealer Data:

Name: _____

Address: _____

Tel (day) _____ (eve) _____

Installing Dealer / Contractor:

Name: _____

Tel: _____

Equipment Data:

SPACEPAK Model # ESP / WCSP - _____

SPACEPAK Serial # _____

SPACEPAK Date of Installation: _____

Cond Unit Mfr: _____

Cond Unit Mod #: _____

Rated Capacity: _____ BTUH; SEER: _____

Air-side Data:

Total # of outlets: _____; Supply tube length: _____ Ft (avg)
(Please sketch duct layout on reverse side of this sheet, noting all fittings and distances, including return duct size / length)

Air Filter: Size (LxHxD) _____

Type (pleated, etc): _____

Is the filter clean? _____ (Y/N)

Static Pressure (Ps) in supply plenum: _____"WG
(Measure at approximately 3 ft downstream of blower discharge)

Ps in return duct (downstream of filter, upstream of coil) _____"WG

SpacePak Motor: Amps (measured): _____ Amps

Voltage (measured): _____ Volts

Air Temperatures:

@ Return (indoor ambient): _____ °FDB; _____ °FWB

@ Condensing unit (outdoor ambient): _____ °F

@ AHU (read 3 ft from fan discharge) _____ °F

@ last supply outlet _____ °F

Refrigeration-side Data:

Line sizes: Liquid _____ Suction _____

Total equivalent length of lines: _____ Ft; Vertical Rise: _____ Ft.

@ Condensing Unit:

Liquid: _____ psi; Temp: _____ °F; Subcool: _____ °F

Suction: _____ psi; Temp: _____ °F; Superheat: _____ °F

@ SpacePak:

Liquid: _____ psi; Temp: _____ °F; Subcool: _____ °F

Suction: _____ psi; Temp: _____ °F; Superheat: _____ °F

Approximate time running before taking readings: _____ Hrs.

Did you adjust the TXV? _____ (Y/N); (If yes, explain):

Refrigerant Charge (if weighed-in): _____ lbs

R410a / R22 (circle one)

Installed options: (circle one)

sight glass filter/drier zone controls

Other: _____

Water Data: (where applicable)

Line sizes: _____"; Length: _____ FT

Water temperatures:

Supply: _____ °F; Return _____ °F

Glycol?: _____ (Y/N); % Solution: _____

NOTES: _____

REF. NO.*	PART DESCRIPTION	UNIT SIZE	PART NUMBER
1	Anti-Frost Control	All Sizes	460RWG0387-01
2	Primary Drain Pan	2430	W06RWG0220-12
	Primary Drain Pan	3642	W06RWG0220-13
	Primary Drain Pan	4860	W06RWG0220-14
3	Coil Assembly R410A	2430	469RWG0379-12
	Coil Assembly R410A	3642	469RWG0379-13
	Coil Assembly R410A	4860	469RWG0379-14
4	Expansion Valve (TXV) R410A	2430	W28RWG0242-12
	Expansion Valve (TXV) R410A	3642	W28RWG0242-13
	Expansion Valve (TXV) R410A	4860	W28RWG0242-14
5	Transformer	All Sizes	W14RWG0061-01
6	Motor	2430	27-3236
	Motor	3642	27-3237
	Motor	4860	27-3238
7	Blower Wheel	2430	27-8032
	Blower Wheel	3642	27-8032
	Blower Wheel	4860	27-8033
8	Terminal Block (high volt)	All Sizes	W09RWG0422-01
9	Electrical Control Box Cover	All Sizes	462RWG0529-01
10	Side Access Panel (coil side)	All Sizes	462RWG0527-01
11	Primary Float Switch	All Sizes	455RWG0543-01
12	Cable Connector (Ground)	All Sizes	W09RWG0313-01
13	Control Board	All Sizes	W11RWG0478-01

*Item locations within control box may vary.

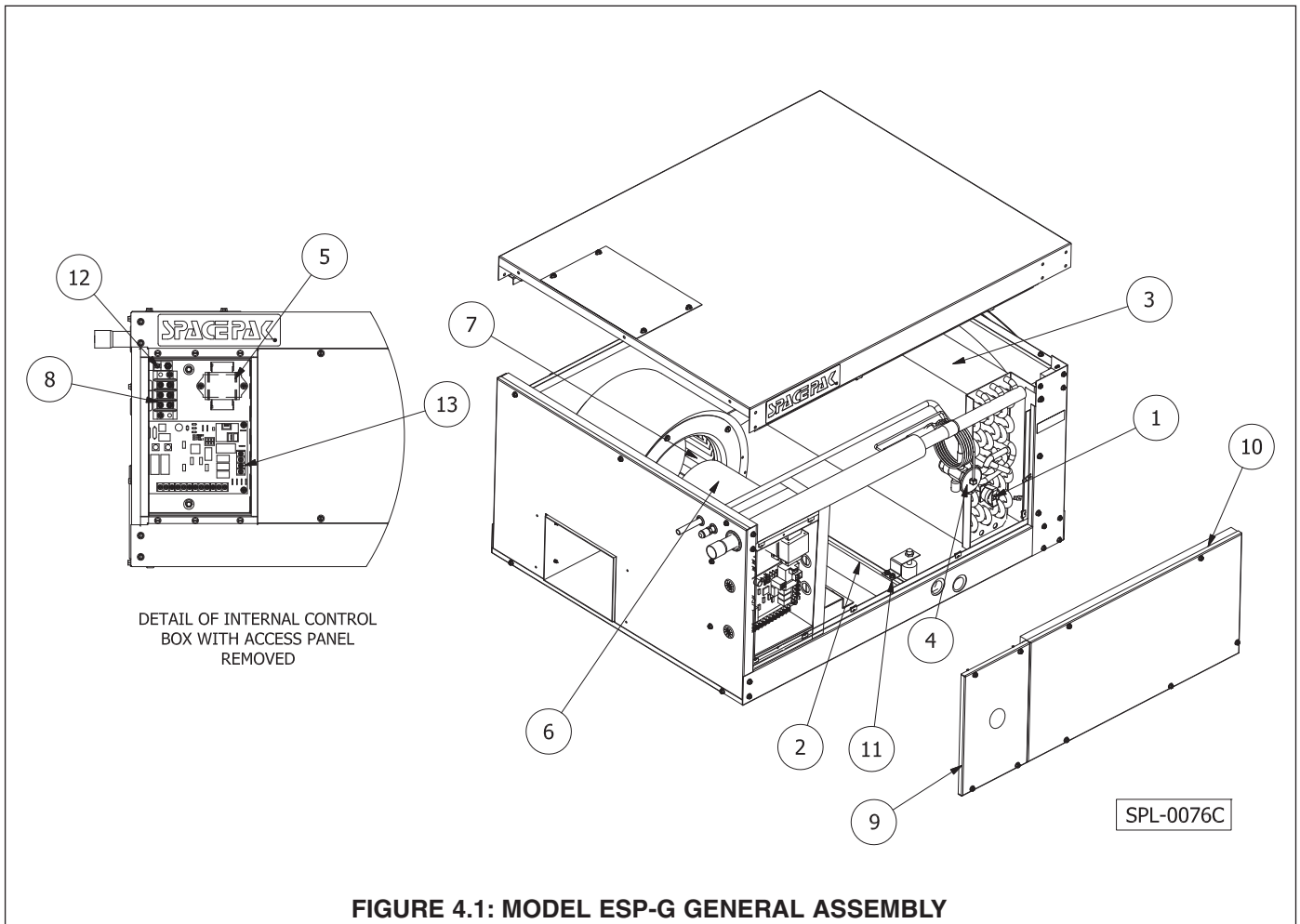

LIMITED WARRANTY

Central Air Conditioning Products

The "Manufacturer" warrants to the original owner at the original installation site that the Central Air Conditioning Products (the "Product") will be free from defects in material or workmanship for a period not to exceed one (1) year from the startup or eighteen (18) months from date of shipment from the factory, whichever occurs first. If upon examination by the Manufacturer the Product is shown to have a defect in material or workmanship during the warranty period, the Manufacturer will repair or replace, at its option, that part of the Product which is shown to be defective.

This limited warranty does not apply:

- a) if the Product has been subjected to misuse or neglect, has been accidentally or intentionally damaged, has not been installed, maintained or operated in accordance with the furnished written instructions, or has been altered or modified in any way.
- b) to any expenses, including labor or material, incurred during removal or reinstallation of the defective Product or parts thereof.
- c) to any workmanship of the installer of the Product.

This limited warranty is conditional upon:

- a) shipment, to the Manufacturer, of that part of the Product thought to be defective. Goods can only be returned with prior written approval from the Manufacturer. All returns must be freight prepaid.
- b) determination, in the reasonable opinion of the Manufacturer, that there exists a defect in material or workmanship.

Repair or replacement of any part under this Limited Warranty shall not extend the duration of the warranty with respect to such repaired or replaced part beyond the stated warranty period.

THIS LIMITED WARRANTY IS IN LIEU OF ALL OTHER WARRANTIES, EITHER EXPRESS OR IMPLIED, AND ALL SUCH OTHER WARRANTIES, INCLUDING WITHOUT LIMITATION IMPLIED WARRANTIES OF MERCHANTABILITY OR FITNESS FOR A PARTICULAR PURPOSE, ARE HEREBY DISCLAIMED AND EXCLUDED FROM THIS LIMITED WARRANTY. IN NO EVENT SHALL THE MANUFACTURER BE LIABLE IN ANY WAY FOR ANY CONSEQUENTIAL, SPECIAL, OR INCIDENTAL DAMAGES OF ANY NATURE WHATSOEVER, OR FOR ANY AMOUNTS IN EXCESS OF THE SELLING PRICE OF THE PRODUCT OR ANY PARTS THEREOF FOUND TO BE DEFECTIVE. THIS LIMITED WARRANTY GIVES THE ORIGINAL OWNER OF THE PRODUCT SPECIFIC LEGAL RIGHTS. YOU MAY ALSO HAVE OTHER RIGHTS WHICH MAY VARY BY EACH JURISDICTION.

