

MODEL ESP-G CENTRAL AIR CONDITIONING / HEAT PUMP SYSTEM 2 TO 5 TONS



SpacePak makes it possible to install central heating and cooling in any home or small business, regardless of structure design, age, size or type of construction. SpacePak is an air distribution system which uses a principle known as aspiration - as the air stream enters the room, it creates a gentle mixing of air in the room to provide thorough, comfortable draft-free air circulation. SpacePak eliminates stratification with a minimum floor-to-ceiling temperature difference.

IDEAL APPLICATION FLEXIBILITY

Can be located nearly anywhere -- attics (fits up through 16"-on-center ceiling joist), basements, crawlspaces and garages.

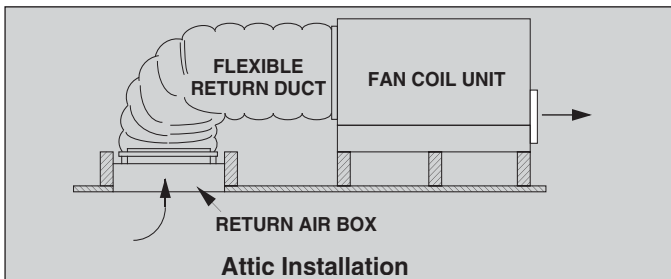

Same unit can be installed for horizontal or vertical supply air flow with simple field conversion.

STANDARD FAN COIL FEATURES

- Corrosion resistant single piece cabinet with durable baked enamel finish. Fully insulated with 1-1/2 lb. density batt.
- Six-row copper tube-aluminum fin evaporator coil removes up to 30% more humidity than conventional coil.
- Heat pump compatible R410A expansion valve factory installed.
- Motor and blower factory-balanced for vibration-free operation.
- Primary and secondary drain connections (3/4" FPT) in durable, polyethylene primary drain pan meet International Mechanical Code 307.2.3. Primary condensate drain assembly included.
- Factory-assembled, pre-wired control center with high voltage terminal block, low voltage transformer and proprietary control board with self diagnostics. Can be relocated up to 10 feet from unit with optional remote mount kit.
- Factory-installed anti-frost control and primary drain pan float switch. Sweat type suction/liquid line connections.
- Schrader valve and refrigerant lines extend through end of cabinet.
- Can be installed with any conventional outdoor condensing unit with capacity and refrigerant line connection meeting SpacePak recommendations.
- Shipped with Nitrogen holding charge.

Model	Nominal System Capacity		Std. CFM @ 1.5" W.C.	Motor HP	F.L. Amps	Connections		Ship Wt. (lbs)	Recommended Condensing Unit Capacity (MBH)
	Nom. Tons	Cool MBH*				Suction Line	Liquid Line		
ESP-2430G	2	21.0	550	1/3	1.8	7/8"	3/8"	120	24
	2-1/2	24.6							30
ESP-3642G	3	33.4	850	1/2	2.8	7/8"	3/8"	144	36
	3-1/2	38.5							42
ESP-4860G	4	45.0	1150	1	5.3	7/8"	3/8"	171	48
	5	54.0							60

NOTES:

Electrical Characteristics: 208-230/60/1.

* For cooling capacity and SEER rating when matched with a specific condensing unit, check the AHRI directory at www.ahridirectory.org.

HOT WATER COIL MODULE

Hot Water Coil Model Number	Fan Coil Unit Model Numbers	BTUH Capacity (Nominal)	Water Connections		Unit Size			Ship Wt. (Lbs.)
			Inlet	Outlet	Height	Depth	Width	
AC-WPAK-60	ESP-2430	60,000	7/8"	7/8"	14"	8-3/4"	24"	28
AC-WPAK-90	ESP-3642	90,000	7/8"	7/8"	14"	8-3/4"	33"	34
AC-WPAK-120	ESP-4860	120,000	7/8"	7/8"	14"	8-3/4"	43"	43

AIR DISTRIBUTION SYSTEM

Pre-fabricated, pre-assembled components, as shown below, can simply be snapped and taped or locked together. With SpacePak, duct sizing is not required.

All systems use the same air distribution components, with the exception of return air ducts and boxes, which helps to simplify component selection, availability and installation.

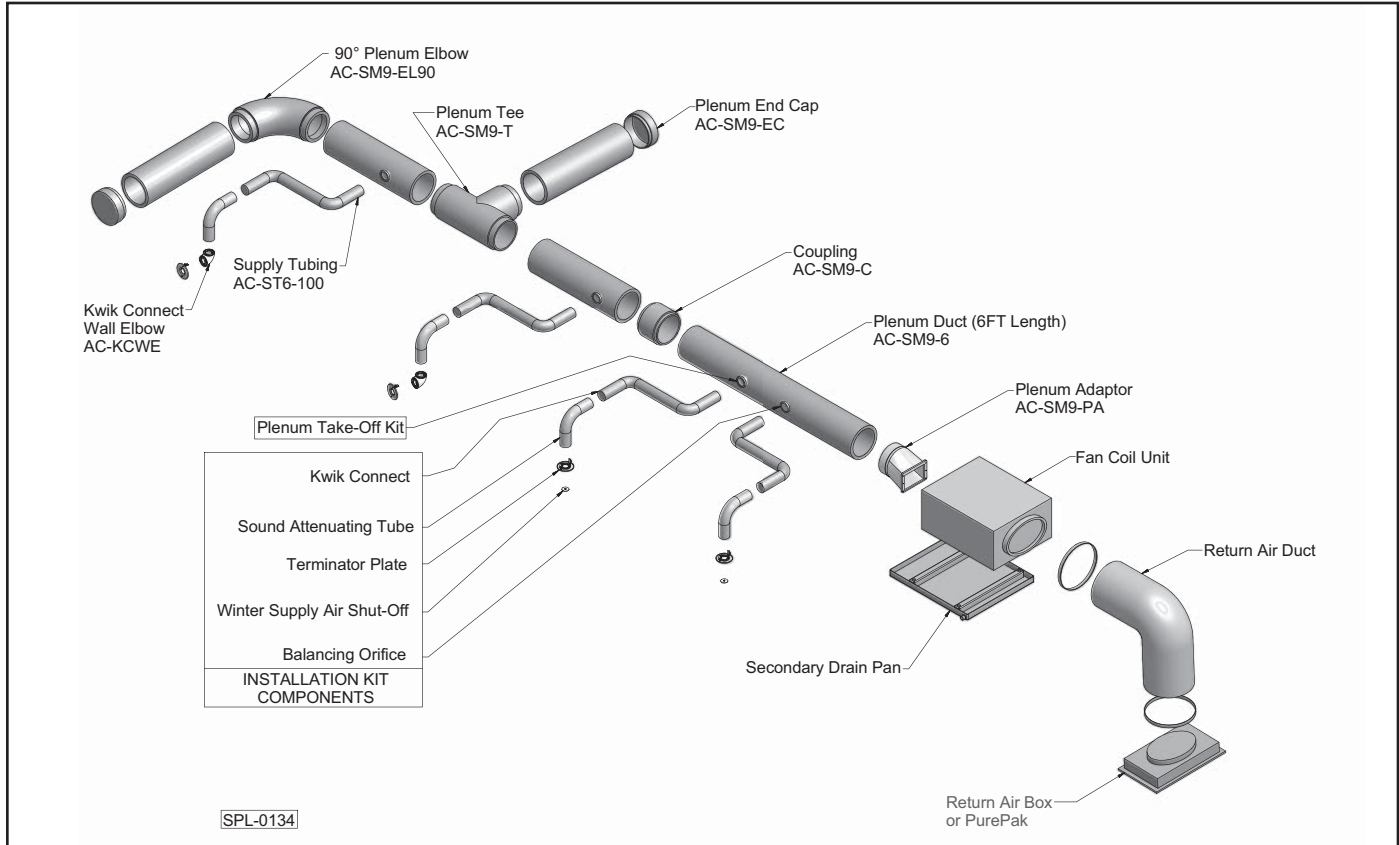

* Shown using SpacePak Smart Seal Duct. Alternate duct options available.

Fan Coil Unit Dimensions

MODEL	Height	Width	Length
ESP-2430G	14-1/8"	24-1/8"	29-3/8"
ESP-3642G	14-1/8"	33-1/8"	29-3/8"
ESP-4860G	14-1/8"	43-1/8"	29-3/8"

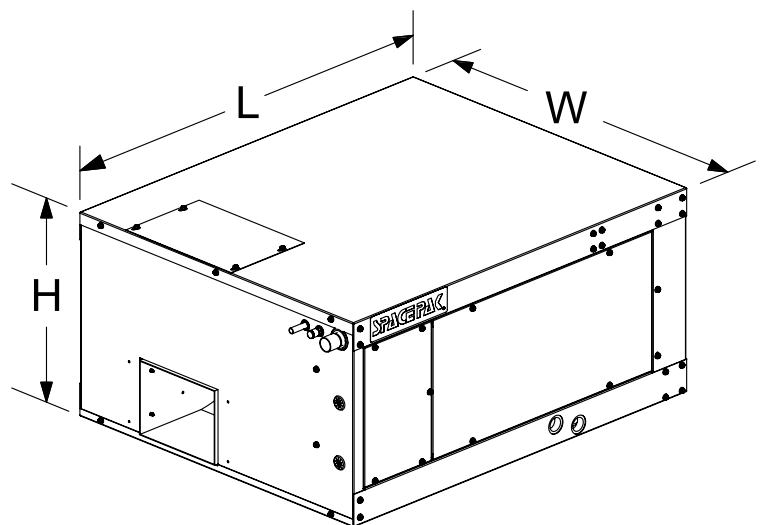

SPL-0071