

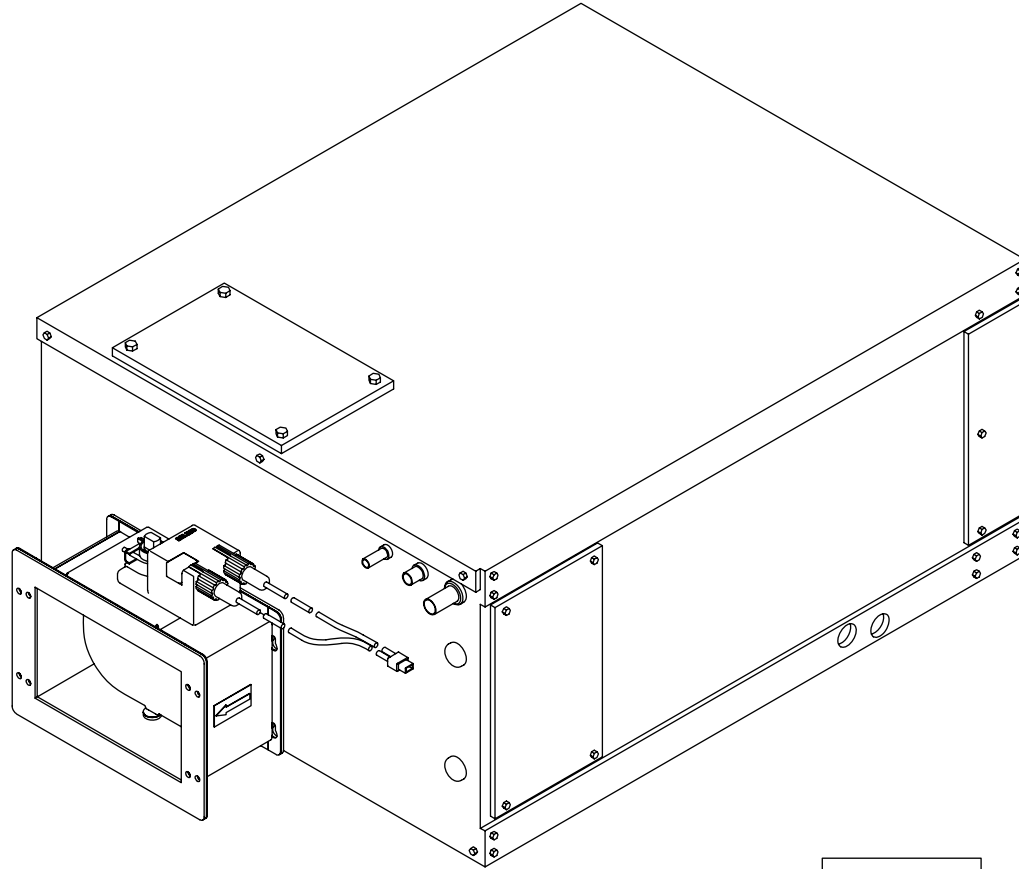

AIR CONTROL MODULE INSTALLATION INSTRUCTIONS FOR "G" SERIES FAN COIL UNITS

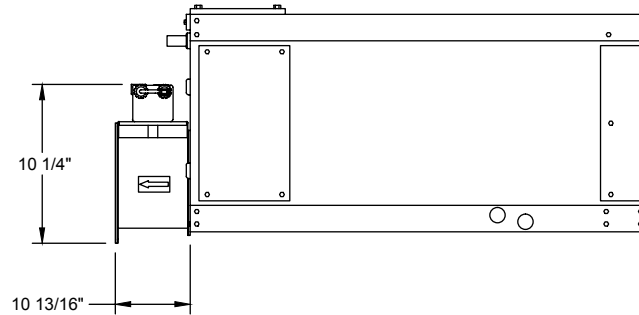

SPL-0104A

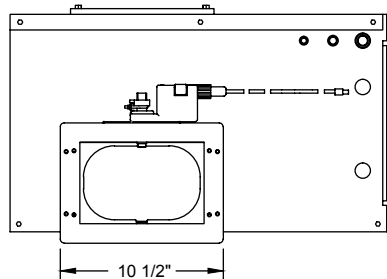

ACM Attachment to Air Handler – refer to Figure 1

1. Insert ACM mounting screws 1/3 deep into the two mounting holes above the supply air opening in the air handler.
2. Position ACM over screws in supply air panel of air handler and push down so that screws bottom into slots.
3. Attach ACM to air handler by tightening upper screws and installing two lower screws.

Figure 1

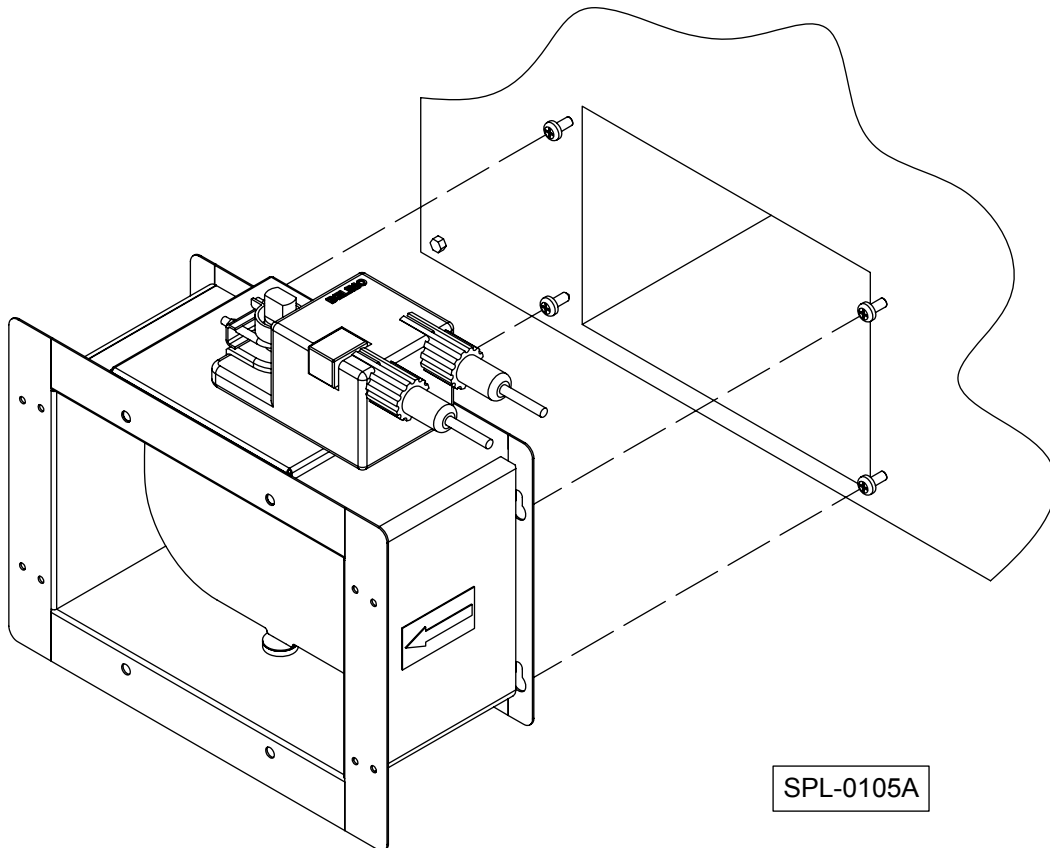

Initial ACM Set Up – refer to Figure 2.

1. Press down manual override button on the actuator and rotate the universal clamp until it contacts stop “1”.
2. Position the ACM damper blade so that it is perpendicular to the supply air panel of air handler (fully open).
3. Tighten nuts on actuator universal clamp with damper blade in fully open position.
4. Adjust reflective position indicator so its tabs are in line with damper blade.
5. Ensure that auxiliary switch is set on the S1/S2 position.

▲ CAUTION The Direction of Rotation Switch must be set to “0”. Setting the Direction of Rotation Switch to “1” will result in improper operation of the SpacePak unit!

Connecting Plenum Duct to ACM

1. Connect Plenum Duct Adaptor per duct installation instructions.
Note: Gasket supplied with Duct Adaptor will not be used.
2. Complete installation of plenum, sound attenuating tubing, room terminators, supply tubing and balancing orifices per ESP-G Installation Manual.

Figure 2

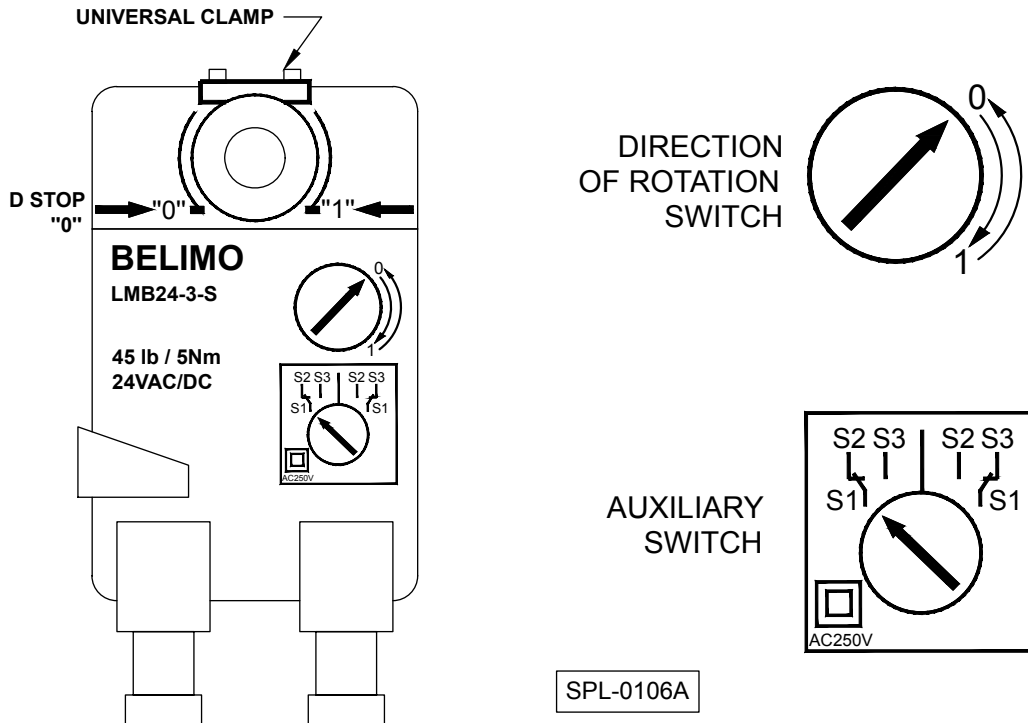

Setting Low Speed Air Flow – refer to Figure 2.

1. Hook amp meter to the L1 blower motor lead.
2. Operate unit so blower comes on.
3. Determine Low Speed CFM desired and select corresponding amperage from Table 1A, 1B, or 1C as applicable.
4. Press down manual override button on actuator and manually rotate the universal clamp until desired amperage is displayed on the amp meter.
5. Adjust end stop "0" so it contacts universal clamp and tighten Phillips-head screws to lock in place. DO NOT loosen universal clamp.

Setting High Speed Air Flow – refer to Figure 2.

1. Hook amp meter to the L1 blower motor lead.
2. Operate unit so blower comes on.
3. Determine High Speed CFM desired and select corresponding amperage from Table 1A, 1B, or 1C as applicable.
4. Press down manual override button on actuator and manually rotate the universal clamp until required amperage is displayed on the amp meter.
5. Adjust end stop "1" so it contacts universal clamp and tighten Phillips-head screws to lock in place. DO NOT loosen universal clamp.
6. Ensure that auxiliary switch is set on the S1/S2 position.

Air Flow Adjustment Chart for 2430 with ACM - Table 1A

Dampener opening	230 Volts		220 Volts		208 Volts	
	AMPS	AIRFLOW (CFM)	AMPS	AIRFLOW (CFM)	AMPS	AIRFLOW (CFM)
▼ This direction Slowly Closed	1.98	734	2.05	724	2.17	708
	1.88	701	1.96	697	2.08	687
	1.82	678	1.88	670	1.99	661
	1.73	648	1.79	639	1.88	634
	1.65	613	1.70	608	1.78	601
	1.50	548	1.53	540	1.59	535
	1.39	492	1.42	480	1.48	480
	1.30	450	1.32	446	1.37	433
	1.23	398	1.25	391	1.28	391

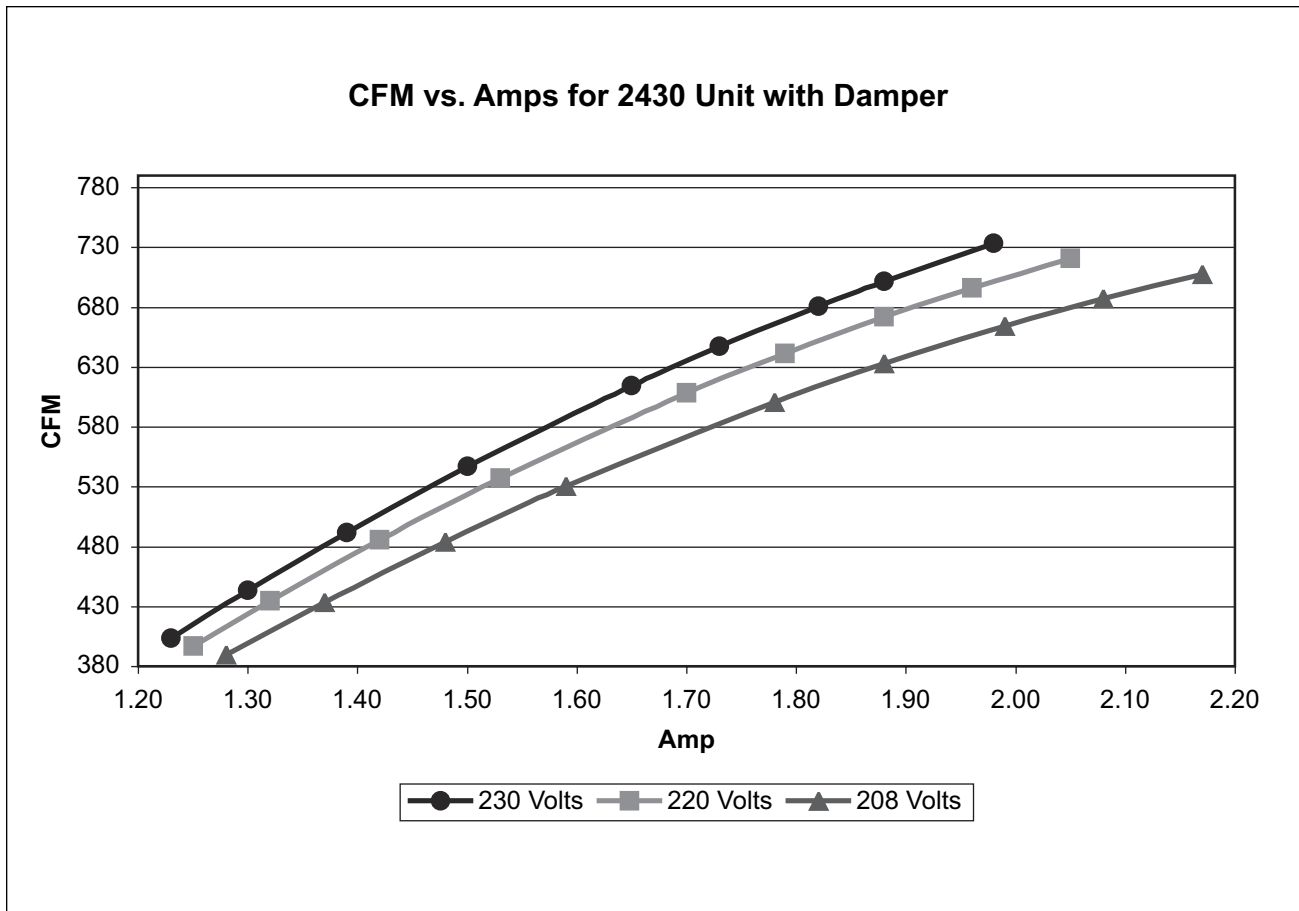

Air Flow Adjustment Chart for 3642 with ACM - Table 1B

Damper opening	230 Volts		220 Volts		208 Volts	
	AMPS	AIRFLOW (CFM)	AMPS	AIRFLOW (CFM)	AMPS	AIRFLOW (CFM)
▼ This direction Slowly Closed	2.69	851	2.76	844	2.88	833
	2.54	842	2.62	838	2.73	824
	2.43	828	2.54	805	2.61	782
	2.35	779	2.40	775	2.50	771
	2.29	767	2.34	755	2.44	748
	2.19	736	2.24	732	2.33	728
	2.11	703	2.16	694	2.22	685
	1.97	645	1.99	640	2.03	626
	1.79	528	1.80	522	1.84	522
	1.62	480	1.62	473	1.63	461
1.55	427	1.54	420	1.55	420	

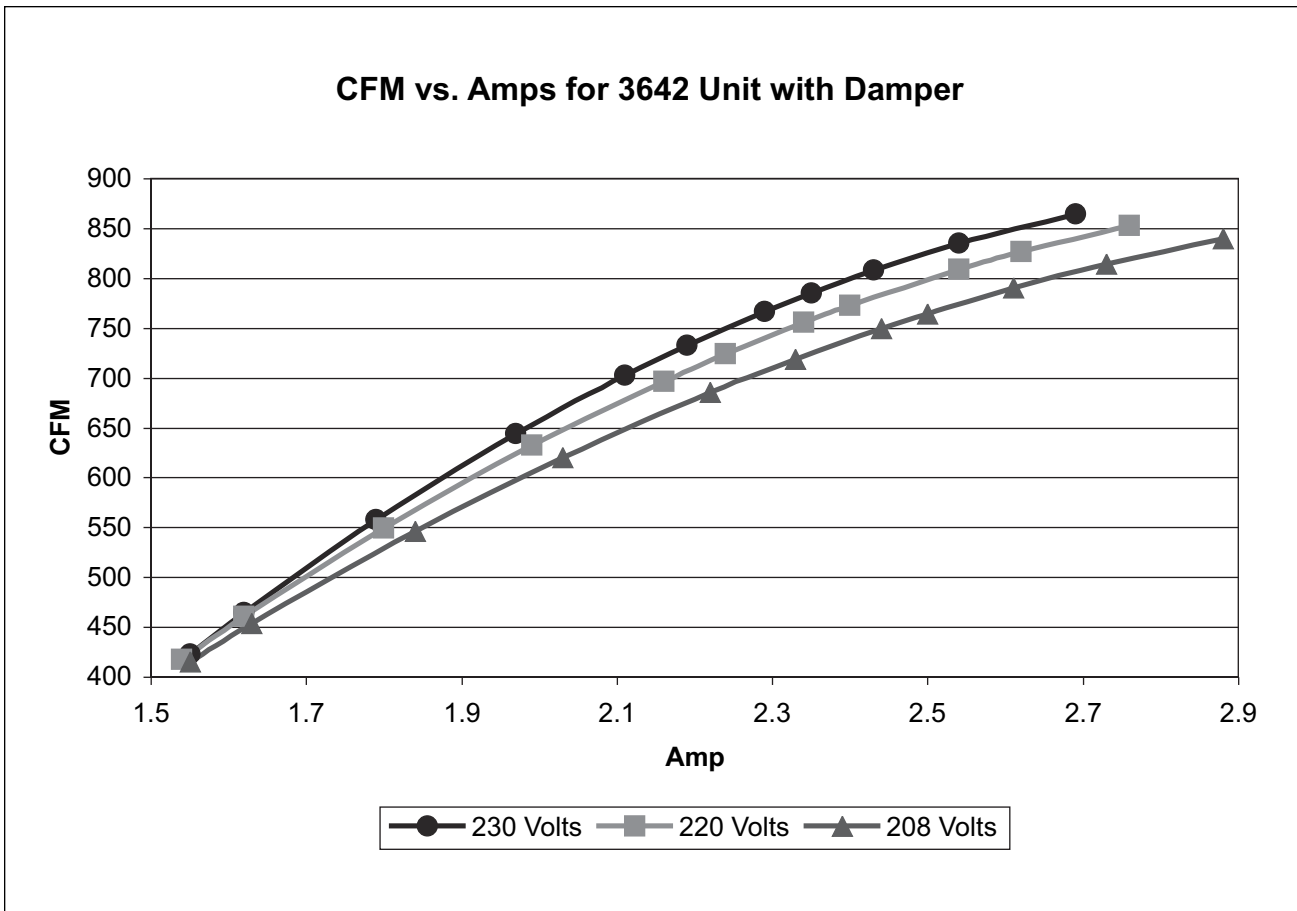

Air Flow Adjustment Chart for 4860 with ACM - Table 1C

Damper opening	230 Volts		220 Volts		208 Volts	
	AMPS	AIRFLOW (CFM)	AMPS	AIRFLOW (CFM)	AMPS	AIRFLOW (CFM)
▼ This direction Slowly Closed	3.87	1200	3.92	1191	4.03	1181
	3.78	1191	3.82	1181	3.92	1172
	3.67	1143	3.68	1133	3.75	1113
	3.49	1072	3.47	1108	3.55	1108
	3.40	1051	3.37	1040	3.41	1029
	3.26	992	3.24	981	3.25	969
	3.09	909	3.03	897	3.03	897
	2.90	818	2.81	804	2.77	804
	2.60	667	2.54	667	2.48	667
	2.51	577	2.40	577	2.30	577
	2.38	470	2.23	470	2.10	470

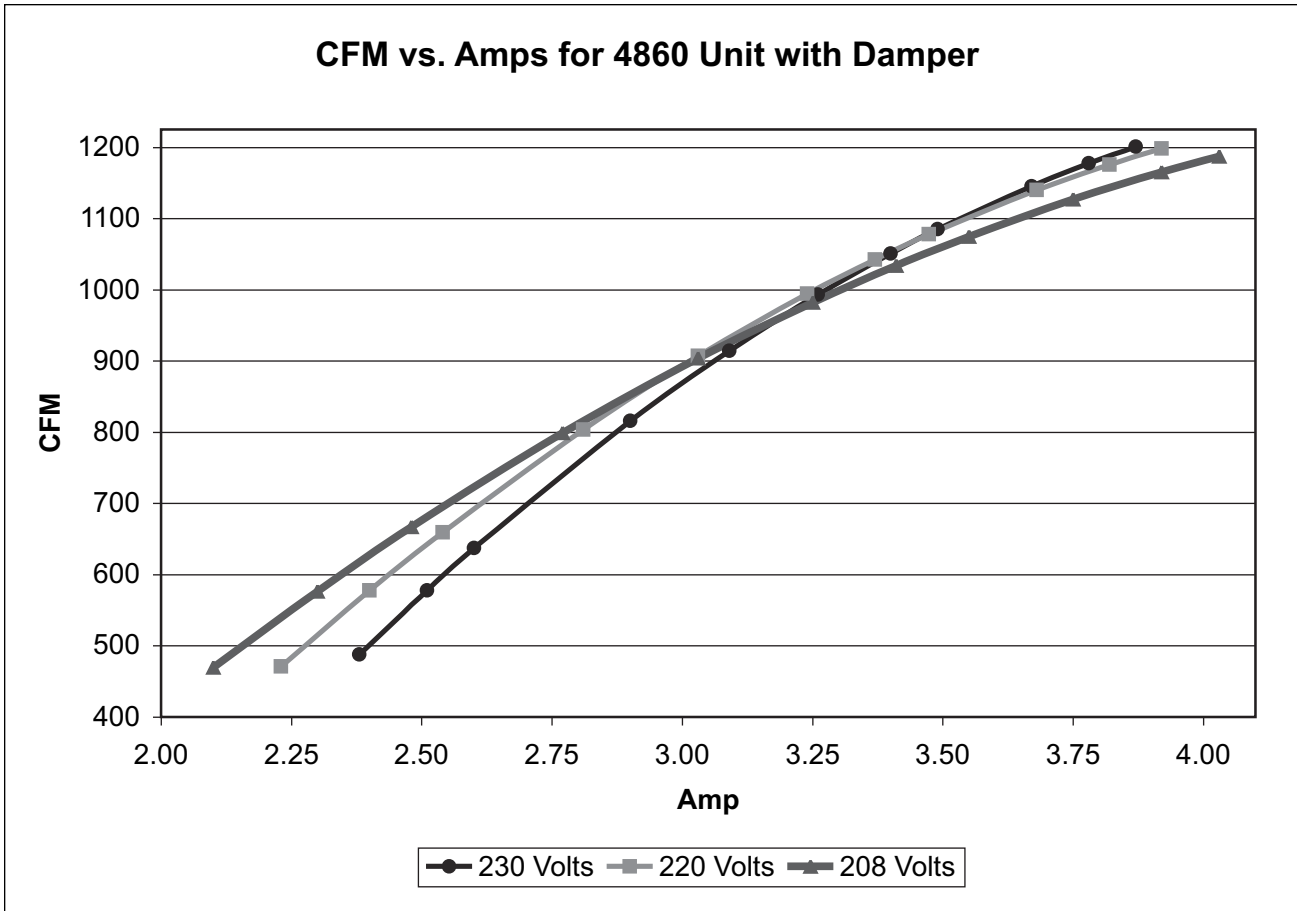

Wiring ACM to Air Handler – refer to Figure 3.

1. Disconnect power to unit
2. Run wire whip attached to ACM actuator through electrical knockout in air handler.
3. Remove Molex jumper connector with red wire loop from control board in air handler.
4. Insert connector from ACM into control board in air handler, being sure to seat securely, but do not force or damage to the board may occur.
5. Restore power to unit.

NOTE: Fan operation will be delayed two minutes on a call for 'Fan Only'

Figure 3

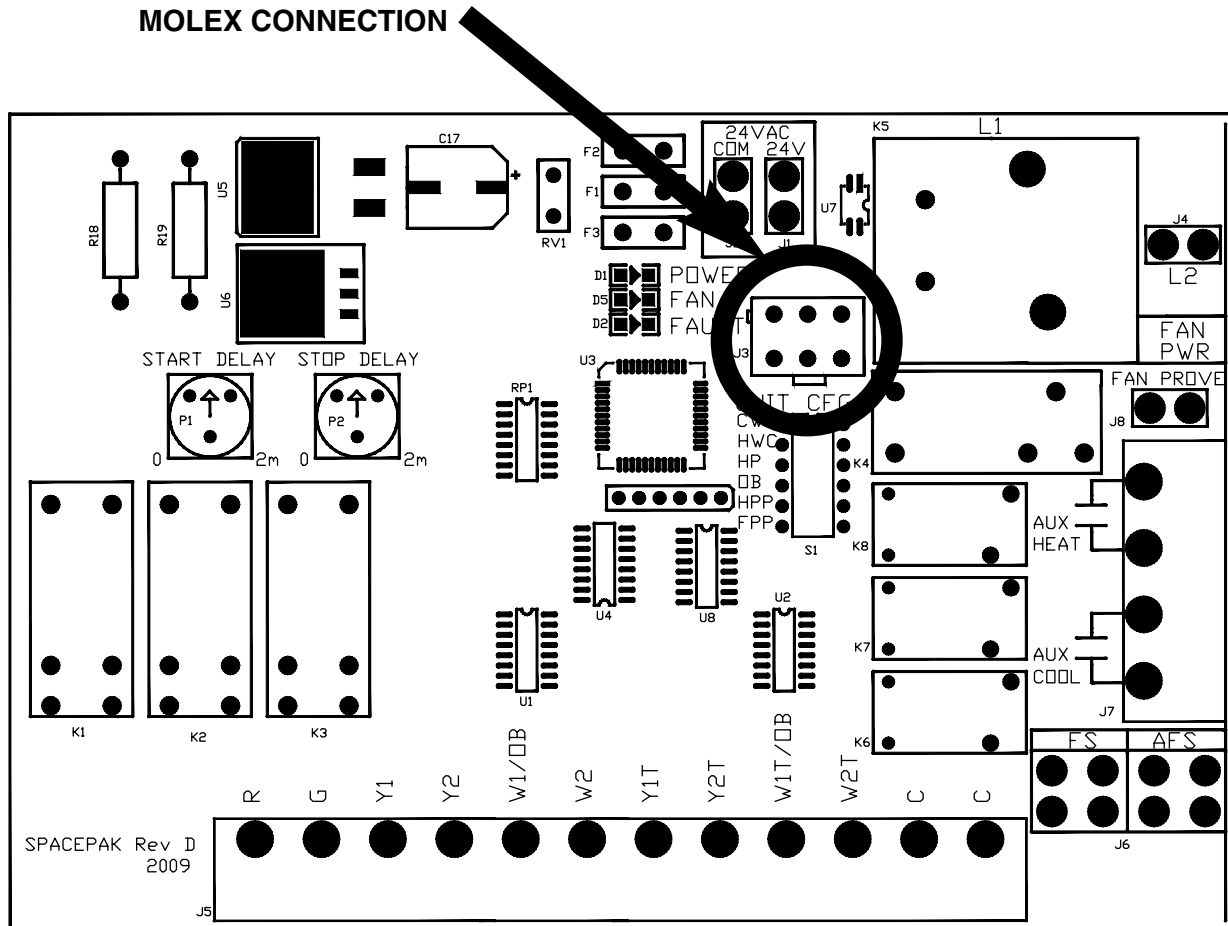

SPL-0107A

IMPORTANT: Refer to ESPG2-709 for detailed instructions on correct DIP switch settings.

LIMITED WARRANTY

Central Air Conditioning Products

The "Manufacturer" warrants to the original owner at the original installation site that the Central Air Conditioning Products (the "Product") will be free from defects in material or workmanship for a period not to exceed one (1) year from the startup or eighteen (18) months from date of shipment from the factory, whichever occurs first. If upon examination by the Manufacturer the Product is shown to have a defect in material or workmanship during the warranty period, the Manufacturer will repair or replace, at its option, that part of the Product which is shown to be defective.

This limited warranty does not apply:

- a) if the Product has been subjected to misuse or neglect, has been accidentally or intentionally damaged, has not been installed, maintained or operated in accordance with the furnished written instructions, or has been altered or modified in any way.
- b) to any expenses, including labor or material, incurred during removal or reinstallation of the defective Product or parts thereof.
- c) to any workmanship of the installer of the Product.

This limited warranty is conditional upon:

- a) shipment, to the Manufacturer, of that part of the Product thought to be defective. Goods can only be returned with prior written approval from the Manufacturer. All returns must be freight prepaid.
- b) determination, in the reasonable opinion of the Manufacturer, that there exists a defect in material or workmanship.

Repair or replacement of any part under this Limited Warranty shall not extend the duration of the warranty with respect to such repaired or replaced part beyond the stated warranty period.

THIS LIMITED WARRANTY IS IN LIEU OF ALL OTHER WARRANTIES, EITHER EXPRESS OR IMPLIED, AND ALL SUCH OTHER WARRANTIES, INCLUDING WITHOUT LIMITATION IMPLIED WARRANTIES OF MERCHANTABILITY OR FITNESS FOR A PARTICULAR PURPOSE, ARE HEREBY DISCLAIMED AND EXCLUDED FROM THIS LIMITED WARRANTY. IN NO EVENT SHALL THE MANUFACTURER BE LIABLE IN ANY WAY FOR ANY CONSEQUENTIAL, SPECIAL, OR INCIDENTAL DAMAGES OF ANY NATURE WHATSOEVER, OR FOR ANY AMOUNTS IN EXCESS OF THE SELLING PRICE OF THE PRODUCT OR ANY PARTS THEREOF FOUND TO BE DEFECTIVE. THIS LIMITED WARRANTY GIVES THE ORIGINAL OWNER OF THE PRODUCT SPECIFIC LEGAL RIGHTS. YOU MAY ALSO HAVE OTHER RIGHTS WHICH MAY VARY BY EACH JURISDICTION.

