



PRODUCT INFORMATION & APPLICATION GUIDE



*The **Original** High Velocity
Central Air Conditioning System*



At home in historical houses and new construction

SpacePak is the original, high-velocity cooling-heating solution for older homes not equipped for central air (heated with hot water, steam or radiant electric heat) and new homes featuring hydronic heating systems, including radiant floor heating. SpacePak's successful track record includes thousands of residential installations and opens up profitable opportunities for contractors. Ease of installation and quiet, efficient operation make SpacePak the number one choice of quality-conscious contractors, homeowners and building owners.

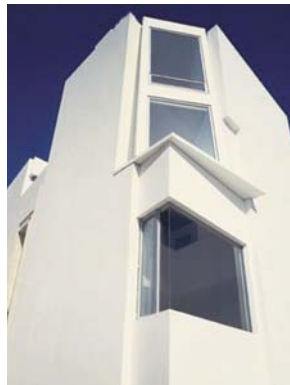

Space-saving versatility with units installed in attics, closets or basements

Ideal for light commercial and institutional applications

The profit potential for SpacePak installations is not limited to residential construction. SpacePak systems may also be installed in a wide variety of commercial and institutional buildings, libraries, municipal buildings, museums, apartment buildings, condos and multi-family housing units. The same attractive installation and performance benefits that make SpacePak ideal for the residential market give contractors and building owners a cost-effective cooling-

heating solution in commercial applications.



SpacePak is also ideal for commercial/institutional buildings and multi-family construction

No major remodeling, speeds and simplifies installation

SpacePak is designed with contractors in mind. Blower units are small enough to fit in attics, basements, crawl spaces and closets. High velocity air is distributed through flexible, pre-insulated 2" diameter ductwork that weaves through wall structures and around obstructions. No large, cumbersome ductwork is required, saving contractors time while reducing installation costs and maintaining architectural integrity.

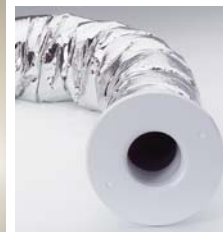

Small diameter, flexible tubing simplifies installation



Quiet and comfort gives contractors a sales edge

SpacePak is ultra quiet and works through the principle of aspiration. Air in the duct is under 5 to 6 times higher pressure than conventional systems. Air exiting the duct expands and creates eddy currents that blend the conditioned air, providing uniform, draft-free temperature from floor to ceiling and room to room. And because SpacePak removes up to 30% more moisture, homeowners are kept cool and comfortable at a higher, more energy efficient thermostat setting.



Removes up to 30% more moisture for enhanced comfort

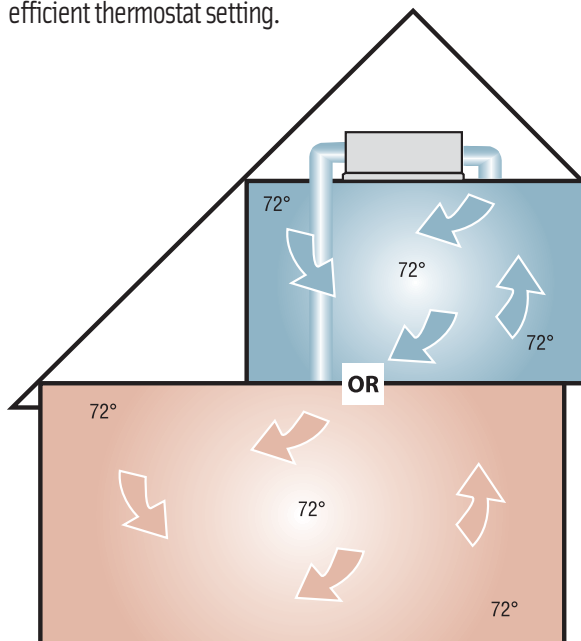

The 'Kwik-Way' to ensure proper sizing

Proper sizing is critical to the performance of the SpacePak system. SpacePak provides an easy to use, 'Kwik-Way' sizing sheet to help contractors calculate the heat gain and/or heat loss of a structure to assure maximum comfort of the occupants. Kwik-Way sizing includes (1) Equipment Selection, Job Estimating and System Design, (2) Room-by-Room Analysis and (3) System Design Considerations. Detailed information can be found in the **SpacePak Factory Trained Installer Handbook** and online at www.spacepak.com.

'Kwik-Connect' makes installation a snap



The SpacePak system features unique 'Kwik-Connect' adapters to save time and money during installation. Simply position the slots and turn to the lock position to provide a secure, air-tight seal for flexible duct connections.

Gentle mixing of air eliminates drafts and minimizes temperature differentials



MODEL ESP-HORIZONTAL

CENTRAL AIR CONDITIONING HEAT PUMP SYSTEM

2 to 5 Tons

One-piece blower unit with DX coil

Standard Fan Coil Features

- Corrosion-resistant cabinet with baked enamel finish
- Fully insulated with 1-1/2 lb. density batt
- Six-row copper tube aluminum fin evaporator coil removes up to 30% more humidity than conventional coil
- Blower motor is factory-balanced for vibration-free operation
- Condensate drain connection in base pan for specially-designed, factory-supplied condensate drain assembly
- Factory-assembled, pre-wired control center with high and low voltage terminal blocks, blower relay and low voltage transformer
- Factory-installed anti-frost control and thermal expansion valve
- Standard factory-installed primary drain pan float switch
- Sweat-type suction/liquid line connections
- Meets or exceeds DOE standards for energy efficiency
- Integrated proprietary control platform
- System diagnostic flash codes
- Plug-in ACM connection
- Simplified wiring

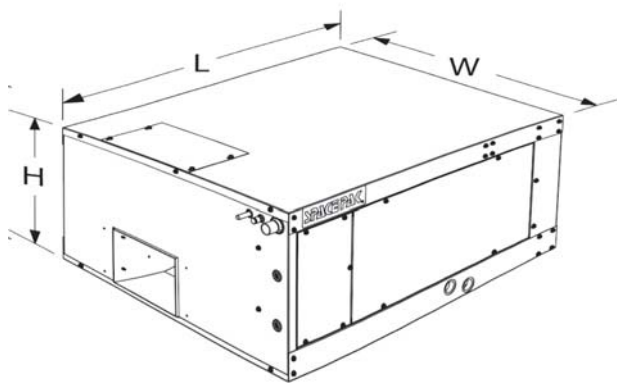

FAN COIL UNIT DIMENSIONS

MODEL	Height	Width	Length
ESP-2430	14-1/8"	24-1/8"	29-3/8"
ESP-3642	14-1/8"	33-1/8"	29-3/8"
ESP-4860	14-1/8"	43-1/8"	29-3/8"

SPECIFICATIONS

Model	Nominal System Capacity		Std. CFM @ 1.5" W.C.	Motor HP	F.L. Amps	Connections		Ship Wt. (lbs.)	Recommended Condensing Unit Capacity (MBH)
	Nom. Tons	Cool MBH				Suction Line	Liquid Line		
ESP-2430G	2	21.0	550	1/3	1.8	7/8"	3/8"	120	24
	2-1/2	24.6	550	1/3	1.8	7/8"	3/8"	120	30
ESP-3642G	3	33.4	850	1/2	2.8	7/8"	3/8"	144	36
	3-1/2	38.5	850	1/2	2.8	7/8"	3/8"	144	42
ESP-4860G	4	45.0	1150	1	3.6	7/8"	3/8"	171	48
	5	54.0	1150	1	3.6	7/8"	3/8"	171	60

Visit www.ahrinet.org to identify compatible condensing units and view associated performance/efficiency ratings

TOTAL COMFORT, WHOLE-HOUSE HEATING and COOLING SYSTEM
For supplemental electric or hydronic heat modules see page 10.



MODEL ESP-VERTICAL

CENTRAL AIR CONDITIONING HEAT PUMP SYSTEM

2 to 5 Tons

One-piece blower unit with DX coil

Standard Fan Coil Features

- Fully-insulated, corrosion-resistant cabinet with baked enamel finish, 1-1/2 lb. density batt
- Six-row copper tube aluminum fin evaporator coil removes up to 30% more humidity than conventional coil
- Blower motor is factory-balanced for vibration-free performance
- Condensate drain connection in base pan for specially-designed, factory-supplied condensate drain assembly
- Factory-assembled, pre-wired control center with high and low voltage terminal blocks, blower relay and low voltage transformer
- Factory-installed anti-frost control and thermal expansion valve
- Standard factory-installed primary drain pan float switch
- Sweat-type water line connections
- All connections located on same side of unit
- Meets or exceeds DOE standards for energy efficiency

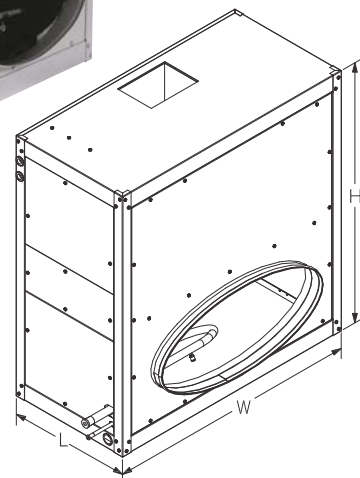

FAN COIL UNIT DIMENSIONS

MODEL	Height	Width	Length
ESP-2430V	34"	24"	16-1/8"
ESP-3642V	34"	33"	16-1/8"
ESP-4860V	34"	43"	16-1/8"

SPECIFICATIONS

Model	Nominal System Capacity		Std. CFM @ 1.5" W.C.	Motor HP	F.L. Amps	Connections		Ship Wt. (lbs.)	Recommended Condensing Unit Capacity (MBH)
	Nom. Tons	Cool MBH				Suction Line	Liquid Line		
ESP-2430V	2	23.0	550	1/3	1.8	7/8"	3/8"	135	24
	2-1/2	27.6	550	1/3	1.8	7/8"	3/8"	135	30
ESP-3642V	3	35.0	850	1/2	2.8	7/8"	3/8"	170	36
	3-1/2	40.0	850	1/2	2.8	7/8"	3/8"	170	42
ESP-4860V	4	48.0	1150	1	3.6	7/8"	3/8"	210	48
	5	57.0	1150	1	3.6	7/8"	3/8"	210	60

NOTES: Electrical characteristics 208-230/1/60. For cooling capacity and SEER rating when mated with a specific condensing unit, check the ARI directory at www.ari.org.

*Visit www.ahrinet.org to identify compatible condensing units and view associated performance/efficiency ratings

TOTAL COMFORT, WHOLE-HOUSE HEATING and COOLING SYSTEM
For supplemental electric or hydronic heat modules see page 10.





MODEL WCSP

CENTRAL AIR CONDITIONING HYDRONIC COIL SYSTEM

2 to 5 Tons

One-piece central unit with chilled water coil

Standard Fan Coil Features

- Ideal for commercial/institutional and Geo-Thermal applications
- Can be installed with conventional chiller or boiler unit as long as capacity and line connections meet SpacePak standards
- Fully insulated blower unit cabinet with baked enamel finish, 1-1/2 lb. density batt
- Six-row copper tube aluminum fin water coil provides efficient operation
- Blower motor is factory-balanced for vibration-free performance
- Condensate drain connection in base pan for specially-designed, factory-supplied condensate drain assembly
- Factory-assembled, pre-wired control center with high and low voltage terminal blocks, blower relay and low voltage transformer
- Standard factory-installed primary drain pan float switch
- Sweat-type water line connections

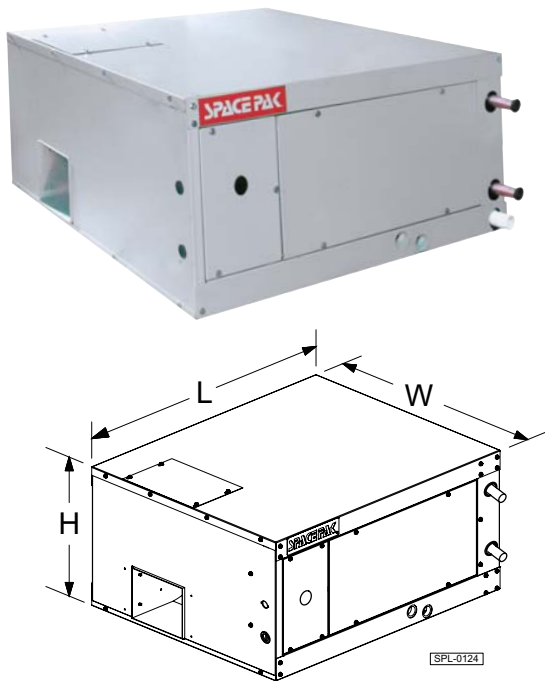

FAN COIL UNIT DIMENSIONS

MODEL	Height	Width	Length
WCSP-2430	14-1/8"	24-1/8"	29-3/8"
WCSP-3642	14-1/8"	33-1/8"	29-3/8"
WCSP-4860	14-1/8"	43-1/8"	29-3/8"

SPECIFICATIONS

Model	Nominal System Capacity		Std. CFM @ 1.5" W.C.	Motor HP	F.L. Amps	Suction Line	Connections		Ship Wt. (lbs.)	Recommended Chiller Unit Capacity (MBH)
	Nom. Tons	Cool MBH					Water In Line	Water Out Line		
WCSP-2430	2	21.0	550	1/3	1.8	7/8"	7/8"	7/8"	120	24
	2-1/2	24.6	550	1/3	1.8	7/8"	7/8"	7/8"	120	30
WCSP-3642	3	33.4	850	1/2	2.8	7/8"	7/8"	7/8"	144	36
	3-1/2	38.5	850	1/2	2.8	7/8"	7/8"	7/8"	144	42
WCSP-4860	4	45.0	1150	1	3.6	7/8"	7/8"	7/8"	171	48
	5	54.0	1150	1	3.6	7/8"	7/8"	7/8"	171	60

TOTAL COMFORT, WHOLE-HOUSE HEATING and COOLING SYSTEM
For supplemental hot water coil heat modules see 'WPAK' page 10.



THERMA-PAK

93% EFFICIENT GAS DIRECT-VENT BOILER

Wall Hung

Standard Features

- 30 MBH to 160 MBH
- Environmentally "green" – NOx 15 ppm
- 93% - Certified DOE efficiency
- 5:1 Continuous Modulation
- Major components fully enclosed:
 - Circulator pump mounted & wired
 - Instantaneous domestic hot water
 - Expansion tank & air vent
- Concentric vent kit
- Patented tri-parallel flow heat exchanger with pre-mix fuel/air combustion process
- 4 GPM of domestic hot water on demand

SPECIFICATIONS

Nominal heat input	160,000 Btu/hr
Minimum heat input	30,000 Btu/hr
Efficiency	93%*
*DOE Heating capacity is based on standard test specified by the United States Department of Energy.	
D.H.W. heat output	142,400 Btu/hr
Instantaneous D.H.W. production (75°F rise)	4 gal/min
Maximum heating temperature	190°F
Maximum heating pressure	30 Psi
Maximum pressure of domestic hot water circuit	125 Psi
Capacity of expansion tank	2.64 gal
Nominal power supply voltage	120/60 V/Hz
Electric power	170 W
Flue gas pipes diameter (split) (polypropylene)	3"
Flue gas pipes max. length (split) (polypropylene)	300 ft
Flue gas pipes diameter (concentric) (polypropylene)	2.36" / 3.94"
Flue gas pipes max. length (concentric) (polypropylene)	70 ft
CO contents (0% O with natural gas)	15 p.p.m.
NOx contents (0% O with natural gas)	15 p.p.m.
Dimensions LxDxH (approximate)	20" x 10" x 33"
Connections (supply - return - D.H.W. - D.C.W. - gas)	3/4"
Weight	100 lbs

* AFUE (DOE Seasonal Efficiency) %



Patented "Tri-Parallel Flow" Heat Exchanger Technology

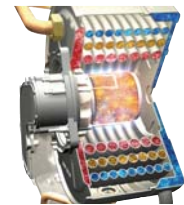

THERMA-PAK DIMENSIONS

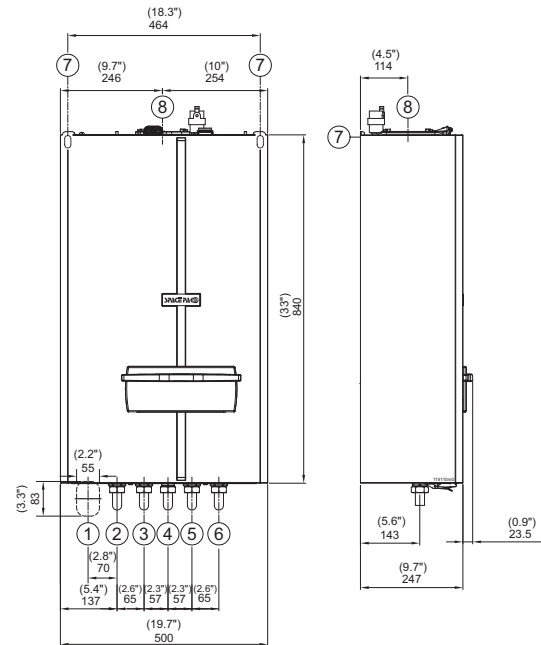

N°	Description	Connections
		Thermo Pak
1	Area for power supply cable	/
2	Heating supply connection	3/4" SWEAT
3	DHW connection	3/4" SWEAT
4	Gas connection	3/4" NPT
5	DCW connection	3/4" SWEAT
6	Heating return	3/4" SWEAT
7	Position for boiler support	/
8	Flue discharge/air intake connection	/





HUMIDITY REMOVAL

30% BETTER HUMIDITY REMOVAL THAN CONVENTIONAL AIR CONDITIONING

ASHRAE PSYCHROMETRIC CHART NO. 1

Normal Temperature
Barometric Pressure

29.921 Inches of Mercury
SEA LEVEL

SpacePak removes humidity and delivers evenly distributed cool air from room to room to ensure superior comfort

SENSIBLE HEAT RATIOS

Sensible Heat Ratios

Conventional = .724

SpacePak = .642

11.5% Lower Sensible Heat Ratio!

Moisture Removal (Dehumidification)

Conventional 14.3 lb/hr

SpacePak 18.6 lb/hr

30% Greater Moisture Removal!

77 Degrees Feels Like 75 Degrees!

© 1992 AMERICAN SOCIETY OF HEATING,
REFRIGERATING AND AIR CONDITIONING ENGINEERS, INC.

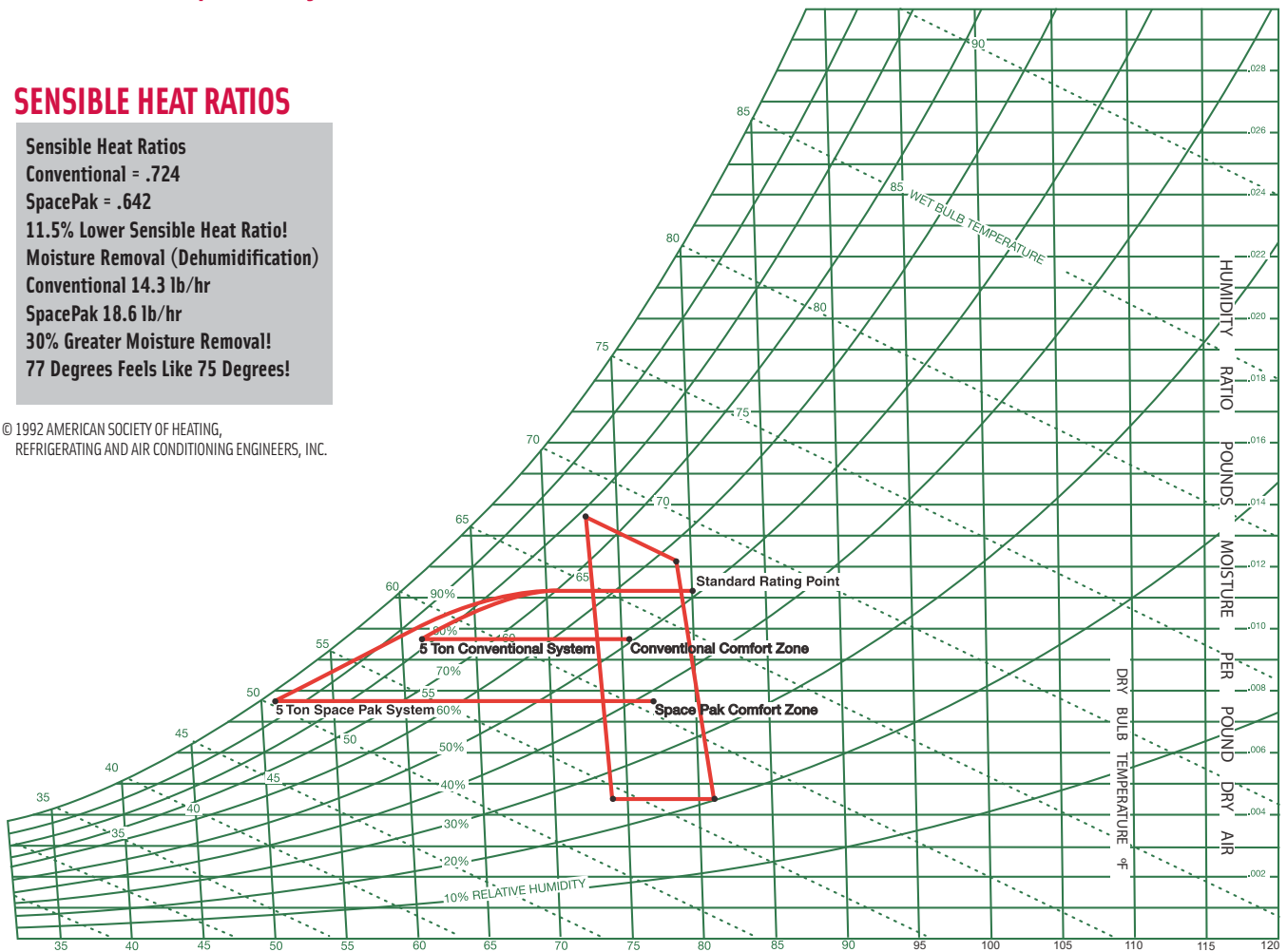

NOTE: All temperature measures listed are Fahrenheit.

SpacePak averages 250 CFM per ton cooling versus 400 CFM for conventional systems. SpacePak's 6-row coil provides a greater temperature drop of the air passing through the coil, typically 24° to 28° F. Specially designed blower pressurizes the duct system 5 to 6 times higher than conventional duct systems. Air exiting into the room is traveling at high velocity, approximately 2000 Ft./Sec. creating floor to ceiling circulation of the air in the room. The air under pressure in the duct system expands as it is released into the room. More moisture is taken out of the air because it is in contact with the coil longer, driving it to a lower dew point temperature. Drier air increases the body's ability to cool itself by perspiration evaporating off the skin. The SpacePak system, by lowering the RH, can run at higher temperature settings. By setting the temperature to 72° instead of 70°, customers can save 15% on their annual cooling energy cost – without sacrificing comfort.

TYPICAL INSTALLATION

EASY TO INSTALL SYSTEM

The SpacePak system has been designed to reduce installation time and cost for installing contractors. Small diameter, flexible tubing weaves around construction obstacles and eliminates the need for large, cumbersome ductwork and major structural renovations. Fittings simply snap securely into place with no tools required. The typical installation diagram and guidelines listed below provide a quick reference to ensure successful installation and operation of the system. More detailed and comprehensive information is available in our **Factory Trained Installer Handbook** and on our website at www.spacepak.com.

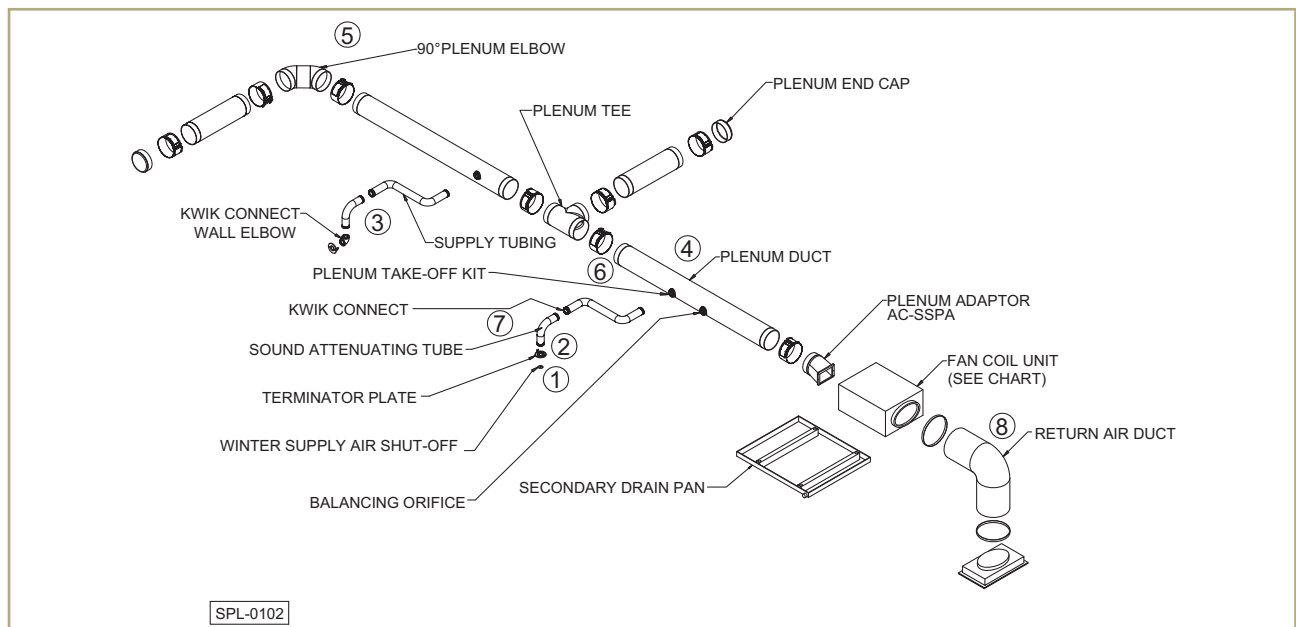

- 1 Outlets** – The most important rule of thumb when installing a SpacePak system is having the proper number of outlets. Six (6) to Seven (7) outlets per ton are recommended for optimal 35–40 CFM airflow from each outlet under normal conditions to maximize aspiration.
- 2 Outlet Placement** – Outlets should be placed in the room where they will create the least disturbance (floors, ceilings, walls) and not infringe upon inhabitants with turbulent air. Traffic patterns, drapes and bed placement are all factors to consider.
- 3 Supply Duct** – Ideally, all runs should be as equal in length as possible. Keep the 2" duct length between 9 ft. and 30 ft. for best performance. The longer the run, the lower the CFM capacity. See performance chart in IOM.
- 4 Main Trunk/Plenum** – Maximize use of the main trunkline in order to minimize the lengths of 2" duct. It will allow for an easier installation and better performing, balanced system if 2" duct lines are minimized.
- 5 60/40 Rule** – Always try to use a full flow "T" in larger, 4–5 ton systems. Never exceed a 60/40 split of outlets off the main trunkline in order to maintain evenly distributed airflow. A perfect 50/50 split is best.
- 6 Locating Take-Offs** – Distribute takeoffs as evenly as possible along the main trunkline – no closer than 6" away from one another. This will assure better balanced airflow.
- 7 Sound Attenuators** – The last 3 ft. of every run should use a fully-fabricated SpacePak sound attenuator to reduce outlet air sound.
- 8 Return Air Duct** – Minimize potential fan noise and maximize performance of this acoustically lined duct by incorporating a 90-degree bend between the air handler and return grille.



VENTILATION AIR POSSIBILITIES

By adding a hot water or electric heating coil, SpacePak becomes a year round cooling and heating ventilation system with continuous blower operation any time a building is occupied and needs to be ventilated. This configuration makes SpacePak ideal for makeup air applications commonly required in office complexes, libraries, schools, apartment buildings and other commercial/institutional buildings.

The benefits for commercial applications include:

- Compact design increases billable space
- Energy recovery compatibility
- Reduces overall cooling load
- Satisfies ASHRAE 62.1 ventilation requirements
- Lowers labor and equipment costs
- Enhances and preserves architectural integrity

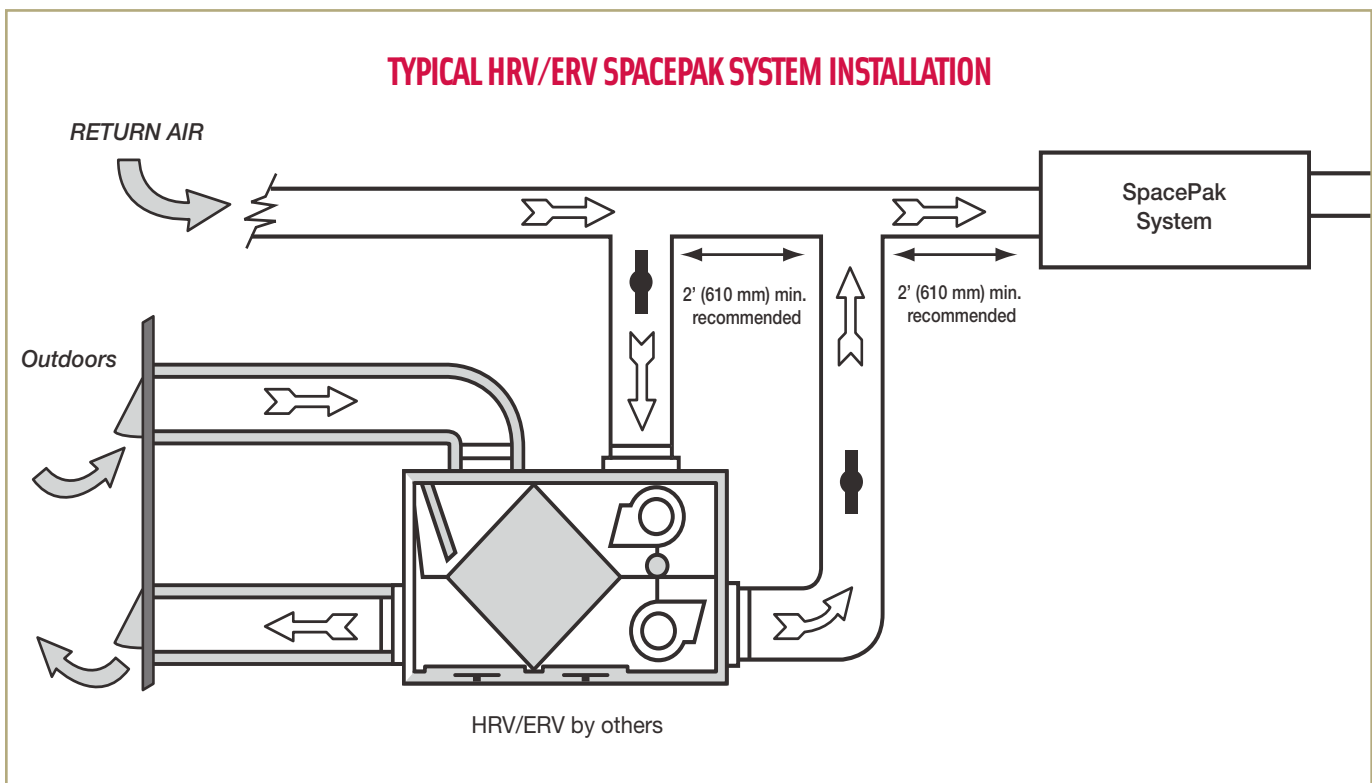

NOTES:

1. Furnace/AC Blower is required to operate when ventilation from HRV/ERV is required.
2. A minimum separation of 24-inches (610 mm) is required between the two direct connections.
3. The exhaust air connection should be upstream of the supply air connection to prevent exhausting any fresh air.
4. Weatherhood arrangement is for drawing purposes only. Six feet (2 m) minimum separation required. Eighteen inches (460 mm) above grade minimum.
5. Due to the differences in pressure between the HRV/ERV and the equipment it is being connected to, the HRV/ERV's airflow must be confirmed on site using the balancing procedure found in the HRV/ERV manufacturers manual.

MODEL ACM

AIR CONTROL MODULE

For "G" Series Fan Coil Units

The SpacePak ACM (Air Control Module) provides the ability to adjust supply air flow allowing for energy savings when operating in fan-only mode. The adjustable damper also offers the means to adjust high speed air flow to provide optimum CFM delivery.

The fully assembled SpacePak ACM is designed to mount directly to the "G" Series Horizontal Fan Coil Unit and is supplied with a molex connector for simple electrical attachment.

One size ACM can be used with all three SpacePak air handler sizes.

Standard ACM Features

- Stainless steel construction
- Insulated housing
- Mounted actuator
- ETL listed
- Compatible with all plenum duct
- Simple plug-in wiring

Benefits

- Precision air volume control
 - Zoning
 - Air circulation
 - IAQ filtration
 - Night set-back
- Soft start – Soft stop
- Maximum energy savings with ultimate comfort control
- Maximum efficiency with 2 speed condensing unit/heat pumps



Air Flow Adjustment Chart For 2430 with ACM

Damper opening	230 Volts		220 Volts		208 Volts	
	AMPS	AIRFLOW (CFM)	AMPS	AIRFLOW (CFM)	AMPS	AIRFLOW (CFM)
▼ This direction Slowly Closed	1.98	734	2.05	724	2.17	708
	1.88	701	1.96	697	2.08	687
	1.82	678	1.88	670	1.99	661
	1.73	648	1.79	639	1.88	634
	1.65	613	1.70	608	1.78	601
	1.50	548	1.53	540	1.59	535
	1.39	492	1.42	480	1.48	480
	1.30	450	1.32	446	1.37	433
	1.23	398	1.25	391	1.28	391

Air Flow Adjustment Chart For 3642 with ACM

Damper opening	230 Volts		220 Volts		208 Volts	
	AMPS	AIRFLOW (CFM)	AMPS	AIRFLOW (CFM)	AMPS	AIRFLOW (CFM)
▼ This direction Slowly Closed	2.69	851	2.76	844	2.88	833
	2.54	842	2.62	838	2.73	824
	2.43	828	2.54	805	2.61	782
	2.35	779	2.40	775	2.50	771
	2.29	767	2.34	755	2.44	748
	2.19	736	2.24	732	2.33	728
	2.11	703	2.16	694	2.22	685
	1.97	645	1.99	640	2.03	626
	1.79	528	1.80	522	1.84	522
	1.62	480	1.62	473	1.63	461
	1.55	427	1.54	420	1.55	420

Air Flow Adjustment Chart For 4860 with ACM

Damper opening	230 Volts		220 Volts		208 Volts	
	AMPS	AIRFLOW (CFM)	AMPS	AIRFLOW (CFM)	AMPS	AIRFLOW (CFM)
▼ This direction Slowly Closed	3.87	1200	3.92	1191	4.03	1181
	3.78	1191	3.82	1181	3.92	1172
	3.67	1143	3.68	1133	3.75	1113
	3.49	1072	3.47	1108	3.55	1108
	3.40	1051	3.37	1040	3.41	1029
	3.26	992	3.24	981	3.25	969
	3.09	909	3.03	897	3.03	897
	2.90	818	2.81	804	2.77	804
	2.60	667	2.54	667	2.48	667
	2.51	577	2.40	577	2.30	577
	2.38	470	2.23	470	2.10	470



ZONE PAK

DAMPER SYSTEM

ZonePak – A unique air-driven damper system – allows for the effortless installation of up to three custom comfort zones working off three independent thermostats. The addition of zoning to the SpacePak system gives installing professionals a tremendous opportunity to offer even more precise comfort to a large segment of the demanding residential and commercial market. ZonePak addresses the unique comfort needs of historical buildings, architecturally challenging structures and anywhere radiant, steam or hot water heat is installed. By delivering conditioned air only where it's wanted, when it's wanted, the needs of all occupants are met while energy costs are reduced.

Benefits of Zoning

- Greater occupant comfort
- Allows for decreases in system capacity demand
- Increased installation flexibility
- Reduced energy consumption

Standard Zone Pak Features

- 2 or 3 zones with one air handler
- Controls integrate with any secondary heat source
- Reliable operation provided by air-driven dampers
- Simple 24 volt wiring
- Quiet operation
- Pre-programmed controls
- Convenient packaged systems



THE ZONE PAK DIFFERENCE

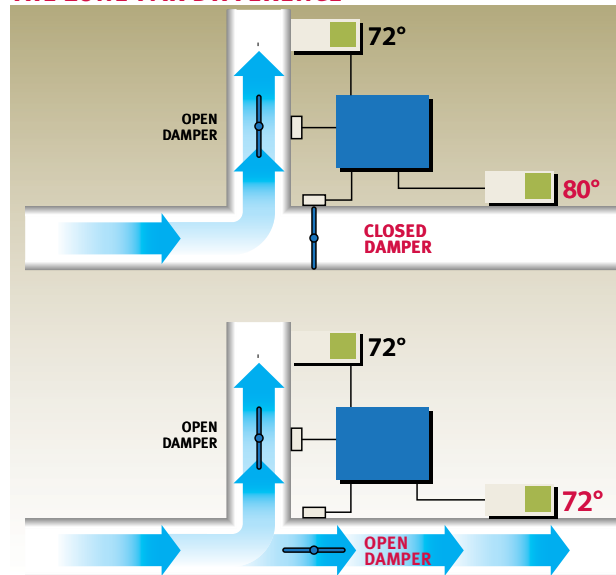

ZonePak's control panel interacts with up to three different thermostats to direct conditioned air from the air handler to whichever zone needs it. The use of branch dampers, with or without plenum dampers, offers even more flexibility.

SMART PAK

SYSTEM DUCT

SmartPak System duct provides homeowners and commercial building owners increased energy efficiency and improved indoor air quality. The unique seal of the SmartPak System duct installs without the use of special tools or messy sealants. It has also proven to be 100% leak resistant to 10" W.C. The SmartPak System plenum adapter allows the duct to be installed level with the bottom of the air handler. Pre-insulated in an R8 sleeve, SmartPak System duct is virtually damage-proof. Holes for take-offs can be drilled almost anywhere without the concern of catching a seam or compromising duct strength. And it installs in less time than most conventional duct systems.

Standard Smart Pak System Duct Features

- 0% Duct leakage
- UL181 Rated proprietary HDPE material
- Patented 100% leak resistant connection system
- Mold and mildew resistant
- Zero VOC's
- Contains up to 40% recycled materials
- Sound dampening qualities
- Recyclable
- Eligible for LEED points

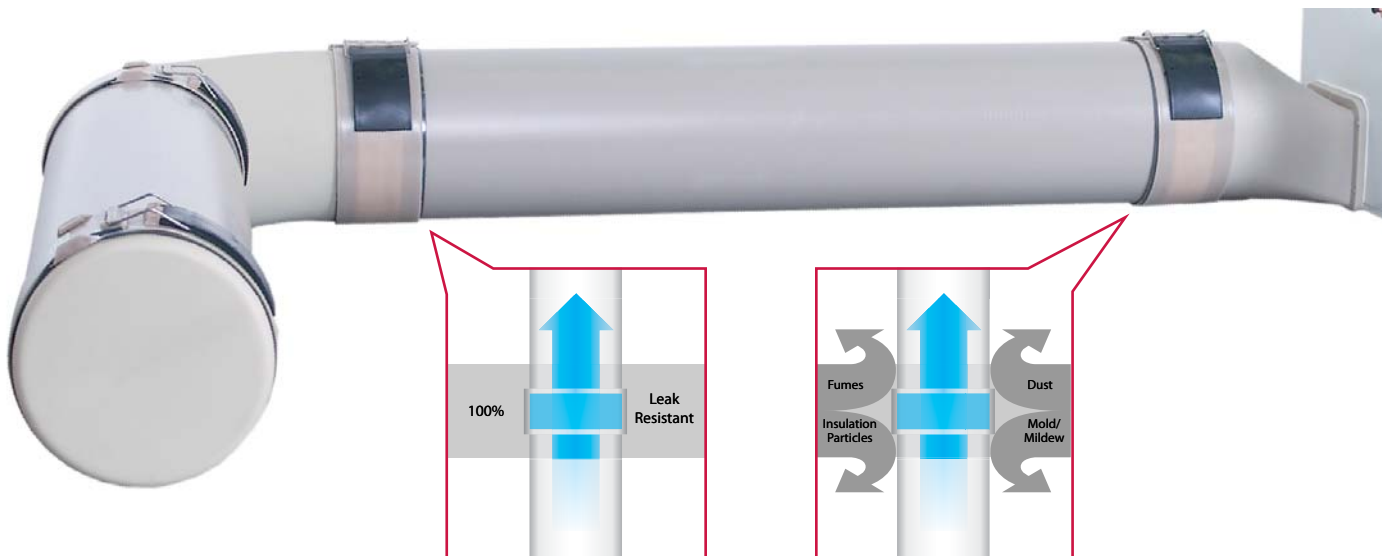
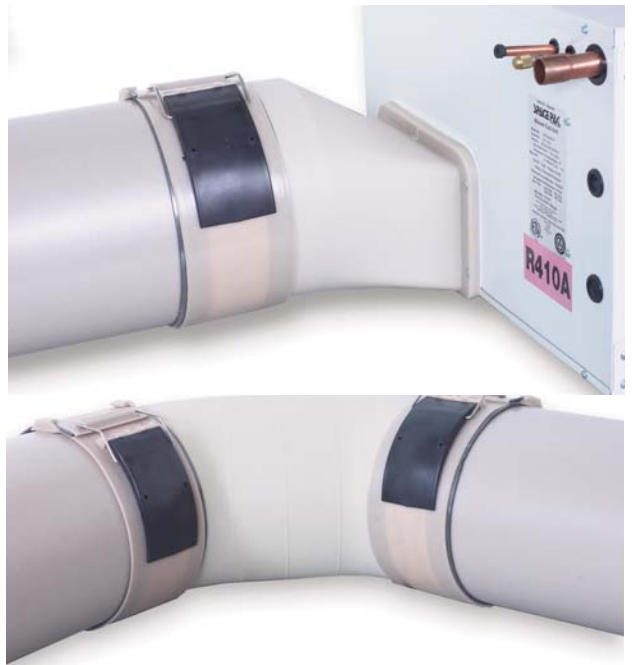

HEATING OPTIONS

ELECTRI PAK

Integral Electric Heat Module for DX Fan Coil Units

Designed to provide a heating option for SpacePak systems. Easy to install in both new and existing systems and fit directly inside horizontal fan coil units. Equipped with an internal modulating feature, heat discharge temperatures are sensed and can be controlled regardless of load condition. Heater design eliminates the need for external regulating devices such as a multi-stage (W3) and/or outdoor thermostat.

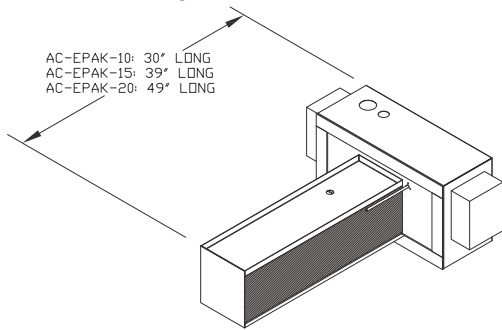

MINIMUM AIR FLOW REQUIREMENTS (CFM)

Electric Heat Module Model	Heat Output @ 240V	208/1/60 FLA MCA		230/1/60 FLA MCA		Fan Coil Unit Model
AC-EPAK-10G	10kW	48	60	43	54	ESP-2430G
AC-EPAK-15G	15kW	72	90	65	82	ESP-3642G
AC-EPAK-20G	20kW	96	120	87	109	ESP-4960G

HEATER COMPATIBILITY/CIRCUIT SIZE

Model	Nominal Air Flow	Minimum Air Flow	Model
AC-EPAK-10G	550	440	ESP-2430G
AC-EPAK-15G	850	680	ESP-3642G
AC-EPAK-20G	1150	920	ESP-4960G

MODEL WPAK HYDRONIC COIL

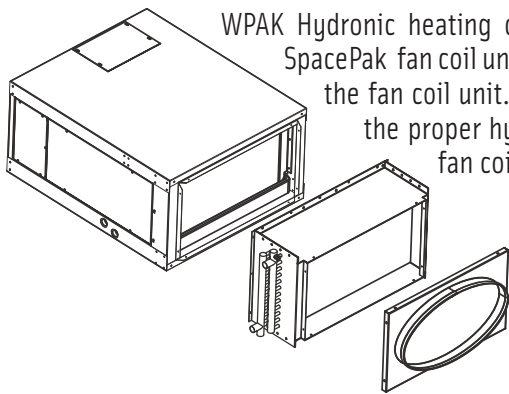

WPAK Hydronic heating coil is designed for use with SpacePak fan coil units. Easily mount to the inlet of the fan coil unit. Use the chart below to match the proper hydronic coil with the SpacePak fan coil unit

Water Pressure Drop (in feet @ 180°)

GPM	AC-WPAK-60	AC-WPAK-90	AC-WPAK-120
2	0.4	0.4	0.5
4	1.4	1.6	1.7
6	3.0	3.3	3.7
8	5.2	5.7	6.3
10	7.9	8.7	9.6

CAUTION:
Areas shaded in tan can exceed 160°F leaving air temperature. To prevent injury or damage, do not install floor outlets when the system is operating in this range.

HEATING CAPACITY MBH

MODEL AC-WPAK-60 for ESP 2430

GPM	Entering Water Temperature (F)				
	120	140	160	180	200
2	20.5	30.0	39.1	48.1	57.2
4	25.2	35.6	46.1	56.6	67.1
6	26.6	37.4	48.3	59.2	70.2
8	27.2	38.2	49.3	60.4	71.6
10	27.5	38.7	49.9	61.1	72.3

At 550 CFM and 70°F Entering Air Temperature*

MODEL AC-WPAK-90 for ESP 3642

GPM	Entering Water Temperature (F)				
	120	140	160	180	200
2	28.8	39.2	51.6	63.4	75.2
4	36.0	50.8	65.7	80.8	95.8
6	39.0	54.9	70.9	87.0	103.1
8	40.4	56.8	73.3	89.9	106.5
10	41.2	57.9	74.7	91.5	108.4

At 850 CFM and 70°F Entering Air Temperature*

MODEL AC-WPAK-120 for ESP 4860

GPM	Entering Water Temperature (F)				
	120	140	160	180	200
2	31.7	46.2	61.2	75.1	89.0
4	45.6	64.2	83.0	102.0	120.9
6	50.6	71.2	92.0	112.9	133.8
8	53.1	74.7	96.4	118.2	140.1
10	54.6	76.7	98.9	121.2	143.6

At 1150 CFM and 70°F Entering Air Temperature*

*To calculate Leaving Air Temperature (LAT) use the following formula: LAT=(BTUH/(1.08XCFM)) +70

OPTIONAL ACCESSORIES

PURE PAK®

RECESSED AIR CLEANER

Removes dangerous airborne particles other cleaning systems miss

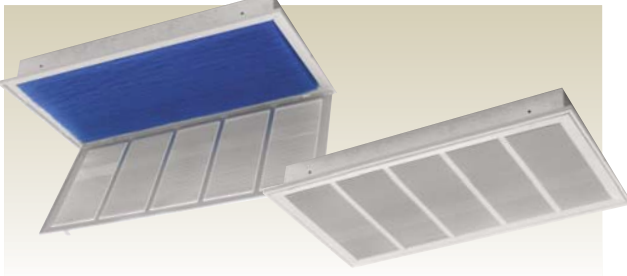

The PurePak system is the key to cleaner, healthier air. It turns the SpacePak system into a whole-house air cleaner quickly and economically. PurePak is controlled by the thermostat fan setting and runs on safe, 24-volt power. It is an easy-to-install, value-added option that your customers will appreciate.

KWIK CONNECT WALL ELBOW

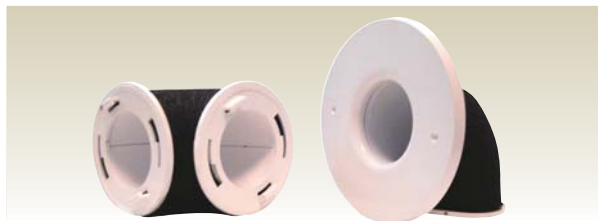

Kwik Connect wall elbows simply snap into place for fast, easy installation.

THERMOSTAT

Features

- Large, back-lit display shows the current and set temperature and time
- Effortless set-up with menu-driven programming
- Real-time clock keeps time during power failures
- "Saving Changes" notification lets you know when changes have been saved



SPACE PAK®



ARCHITECTURAL OUTLETS

Blend with any décor



SpacePak offers the widest variety of Architectural Outlets and Covers to blend with any décor. From finished aluminum and brass to Victorian elegance to natural wood grain.

LINEAR SLOT OUTLET



Linear slot outlet is designed for installation in both new construction and retrofit applications. The fully integrated outlet requires no additional mounting hardware and is supplied with a trim plate that boasts a slim profile less than 1/8 inch.

BASE PAK SECONDARY DRAIN PANS FOR HORIZONTAL FAN COIL UNITS



- Durable polyethylene will not rust
- Resistant to mold growth
- UL recognized material
- Integral, multi-function support channels
- Supports unit when suspended with threaded rod
- Fits through hole cut-out used for return air box
- Threaded 3/4" drain connection
- Meets International Mechanical Code 307.2.3



TRAINING & SALES SUPPORT

SpacePak offers comprehensive installation training and effective sales support and promotional tools for installing contractors. As a Factory Trained Installer you will save time and money on every job and receive an Extended 5-Year Warranty on installed systems. SpacePak training classes are held at the Reed Institute, located in Westfield, MA, and at various locations throughout the country.

Pre-printed sales support materials include homeowner brochures, yard signs, door hangers, truck decals, homeowner direct mail pamphlets, customizable print advertisements and more. Call a local sales representative at **800-465-8558** for more information about SpacePak training and sales support.



The SpacePak Factory Trained Installer Handbook is a resource of knowledge for every aspect of a SpacePak system, featuring product information, specifications and engineering drawings.

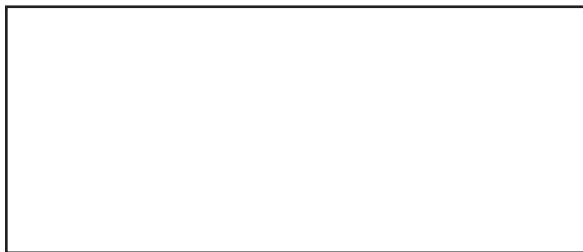

260 North Elm Street, Westfield, MA 01085, Tel. 800-465-8558 • Canada: 7555 Tranmere Drive, Mississauga, Ontario, L5S 1L4, Canada, Tel. 905-672-2991

www.spacepak.com

A MESTEK COMPANY

SCB-2