



# FUTERA FUSION SERIES FINNED COPPER GAS BOILERS (MODEL CB) & WATER HEATERS (MODEL CW) INSTALLATION & OPERATION MANUAL



DESIGNED AND TESTED ACCORDING TO A.S.M.E. BOILER AND PRESSURE VESSEL CODE, SECTION IV FOR A MAXIMUM ALLOWABLE WORKING PRESSURE OF 160 PSI, 1103 kPa WATER.

**WARNING:** If the information in this manual is not followed exactly, a fire or explosion may result causing property damage, personal injury or loss of life.

Do not store or use gasoline or other flammable vapors and liquids in the vicinity of this or any other appliance.

#### WHAT TO DO IF YOU SMELL GAS:

- Do not try to light any appliance.
- Do not touch any electrical switch. Do not use any phone in your building.
- Immediately call your gas supplier from a neighbor's phone. Follow the gas supplier's instructions.
- If you cannot reach your gas supplier, call the fire department.

Installation and service must be performed by a qualified installer, service agency or the gas supplier.

**WARNING:** Failure to properly vent this unit can cause excessive amounts of carbon monoxide resulting in severe personal injury or death!

INSTALLER, THESE INSTRUCTIONS TO BE AFFIXED ADJACENT TO THE BOILER / WATER HEATER.  
CONSUMER, RETAIN THESE INSTRUCTIONS FOR FUTURE REFERENCE PURPOSES.



260 North Elm Street  
Westfield, MA 01085  
Phone: (413) 568-9571  
Fax: (413) 568-9613

7555 Tranmere Drive  
Mississauga, Ontario L5S 1L4 Canada  
Phone: (905) 670-5888  
Fax: (905) 670-5782



# FUTERA FUSION INSTALLATION AND OPERATION INSTRUCTIONS

**AVERTISSEMENT.** Assurez-vous de bien suivre les instructions données dans cette notice pour réduire au minimum le risque d'incendie ou d'explosion ou pour éviter tout dommage matériel, toute blessure ou la mort

Ne pas entreposer ni utiliser d'essence ou ni d'autres vapeurs ou liquides inflammables à proximité de cet appareil ou de tout autre appareil.

## QUE FAIRE SI VOUS SENTEZ UNE ODEUR DE GAZ:

- Ne pas tenter d'allumer d'appareil.
- Ne touchez à aucun interrupteur; ne pas vous servir des téléphones se trouvant dans le bâtiment.
- Appelez immédiatement votre fournisseur de gaz depuis un voisin. Suivez les intructions du fournisseur.
- Si vous ne pouvez rejoindre le fournisseur, appelez le service des incendies.

L'installation et l'entretien doivent être assurés par un installateur ou un service d'entretien qualifié ou par le fournisseur de gaz.

## CONTENTS

Before You Start	page 2
Ratings & Capacities	page 3
Boiler/Water Heater Location	page 3
Combustion Air & Ventilation	page 3
General Venting Guidelines	page 5
General Piping Requirements	page 11
Heating System Piping	page 11
Domestic Water Supply Piping	page 16
Gas Supply Piping	page 20
Electrical Wiring	page 21
General Operation	page 21
Operating Instructions	page 22
Checking & Adjustments	page 24
Control Description	page 25
MPA Staging Control	page 25
Diagnostics	page 27
Maintenance	page 27
Trouble-Shooting	page 29
Repair Parts	page 31
Startup Sheet	page 38

## BEFORE YOU START

This manual covers the application, installation, operation and maintenance of a Futera Fusion Series finned copper heating boiler/water heater.

To obtain the safe, dependable, efficient operation and long life for which this heating boiler/water heater was designed, these instructions must be read, understood and followed.

The Futera Fusion Series finned copper heating boiler/water heaters have been design certified by CSA for use with natural and propane gas under the latest revision of ANSI-Z21.10.3/CSA 4.3, Gas Water Heaters, ANSI-Z21.13/CSA 4.9, Gas-Fired Low Pressure Steam and Hot Water Boilers and CAN1-3.1, Industrial and Commercial Gas Fired Packaged Boilers. Each unit has been constructed and hydrostatically tested for a maximum working pressure of **160 psi, 1103 kPa** in accordance with Section IV of the A.S.M.E. Boiler and Pressure Vessel Code.

All aspects of the boiler/water heater installation must conform to the requirements of the authority having jurisdiction, or, in the absence of such requirements, to the National Fuel Gas Code, ANSI Z223.1/NFPA 54-latest revision. Where required by the authority having jurisdiction, the installation must conform to the Standard for Controls and Safety Devices for Automatically Fired Boilers, ANSI/ASME CSD-1.

In Canada, the installation must be in accordance with the requirements of CSA B149.1 or .2, Installation Code for Gas Burning Appliances and Equipment.

If installed in the Commonwealth of Massachusetts, you **MUST FOLLOW** the additional instructions contained in RBI's instruction sheet "MACODE". If you don't have a copy call your RBI representative.

The owner should maintain a record of all service work performed with the date and a description of the work done. Include the name of the service organization for future reference.

Direct all questions to your RBI distributor or contact the RBI Customer Service Department at: 260 North Elm Street, Westfield, MA 01085 for US or 7555 Tranmere Drive, Mississauga ONT L5S 1L4 for Canada. Always include the model and serial numbers from the rating plate of the boiler/water heater in question.

# FUTERA FUSION INSTALLATION AND OPERATION INSTRUCTIONS

## RATINGS & CAPACITIES

Before undertaking the installation of the Futera Fusion Series boiler/water heater check the rating plate to ensure that the unit has been sized properly for the job. The “Net I=B=R Ratings” specify the equivalent amount of direct cast iron radiation that the unit can supply under normal conditions. Also ensure that the unit has been set up for the type of gas available at the installation site. Other important considerations are the availability of an adequate electrical supply, fresh air for combustion and a suitable chimney or vent system.

## BOILER/WATER HEATER LOCATION

1. This boiler/water heater is suitable for indoor installations. Locate the boiler/water heater in an area that provides good access to the unit. Servicing may require the removal of jacket panels. Allow the minimum clearances between adjacent construction and the boiler/water heater as listed in Table 1.

**NOTE: Service clearances are not mandatory, but are recommended to ensure ease of service should it be required.**

Table 1

	Clearance to Combustibles		Service Clearance	
	in	mm	in	mm
Top	6	153	30	762
Back	6	153	24	610
Left Side	6	153	24	610
Right Side	6	153	24	610
Front	6	153	30	762

2. An optimum site will be level, central to the piping system, close to a chimney or outside wall and have adequate fresh air for combustion. Ensure that the boiler/water heater is level from front to back and from side to side. Use metal shims to level the boiler/water heater. Electrical and electronic components must also be protected from exposure to water during operation and maintenance. DO NOT install this boiler/water heater in a location that would subject any of the gas ignition components to direct contact with water or excessive moisture during operation or servicing.
3. Ensure that the floor is structurally sound and will support the weight of the boiler/water heater.

**NOTE: The Futera Fusion may be installed directly on combustible flooring, but never on carpeting.**

4. Locate the boiler/water heater in an area that will prevent water damage to adjacent construction should a leak occur or during routine maintenance. If such a location doesn't exist, a suitable drain pan that's adequately drained must be installed under the unit.
5. DO NOT place this boiler/water heater in a location that would restrict the introduction of combustion air into the unit or subject it to a negative pressure, see “GENERAL VENTING GUIDELINES”.

6. NEVER place this boiler/water heater in a location that would subject it to temperatures at or near freezing, see the “FREEZE PROTECTION” section on page 11.

**WARNING: Never store combustible materials, gasoline or any product containing flammable vapors or liquids in the vicinity of the boiler/water heater. Failure to comply with this warning can result in an explosion or fire causing extensive property damage, severe personal injury or death!**

## COMBUSTION AIR & VENTILATION

**WARNING: This boiler/water heater must be supplied with combustion air in accordance with Section 5.3, Air for Combustion & Ventilation, of the latest revision of the National Fuel Gas Code, ANSI Z223.1/NFPA 54 and all applicable local building codes. Canadian installations must comply with CAN/ CGA B149.1 or .2 Installation Code for Gas Burning Appliances and Equipment, or applicable provisions of the local building codes. Failure to provide adequate combustion air for this boiler/water heater can result in excessive levels of carbon monoxide which can result in severe personal injury or death!**

To operate properly and safely this boiler/water heater requires a continuous supply of air for combustion. NEVER store objects on or around the boiler/water heater!

**CAUTION: Combustion air contaminated with fluorocarbons or other halogenated compounds such as cleaning solvents and refrigerants will result in the formation of acids in the combustion chamber. These acids will cause premature failure of the boiler/water heater voiding the warranty!**

**CAUTION: If the boiler/water heater is operated while the building is under construction it MUST be protected from wood, concrete, sheet rock and other types of dust. Failure to properly protect the unit from construction dust will damage the unit voiding the warranty!**

Buildings will require the installation of a fresh air duct or other means of providing make-up air if the intake air option isn't used. Any building utilizing other gas burning appliances, a fireplace, wood stove or any type of exhaust fan must be checked for adequate combustion air when all of these devices are in operation at one time. Sizing of an outside air duct must be done to meet the requirements of all such devices.

**WARNING: Never operate the Futera Fusion in an environment subjected to a negative pressure unless it is Direct Vented. Failure to comply with this warning can result in excessive levels of carbon monoxide causing severe personal injury or death!**

# FUTERA FUSION INSTALLATION AND OPERATION INSTRUCTIONS

## All Air From Inside The Building

If the Futera Fusion is to be located in a confined space, the minimum clearances listed in Table 1 must be maintained between it and any combustible construction. When installed in a confined space **without the intake air option**, Figures 5, and 6, two permanent openings communicating with an additional room(s) are required. The combined volume of these spaces must have sufficient volume to meet the criteria for an unconfined space. The total air requirements of all gas utilization equipment, fireplaces, wood stoves or any type of exhaust fan must be considered when making this determination. Each opening must have a minimum free area of **1 in<sup>2</sup>/1000 Btu/hr, 2200 mm<sup>2</sup>/kW** based on the total input rating of ALL gas utilization equipment in the confined area. Each opening must be no less than **100 in<sup>2</sup>, 64,516 mm<sup>2</sup>** in size. The upper opening must be within **12 in, 305 mm** of, but not less than **3 in, 76 mm** from, the top of the enclosure. The bottom opening must be within **12 in, 305 mm** of, but not less than **3 in, 76 mm** from, the bottom of the enclosure.

## All Air From Outside The Building

When installed in a confined space **without utilizing the intake air option** two permanent openings communicating directly with, or by ducts to, the outdoors or spaces that freely communicate with the outdoors must be present. The upper opening must be within **12 in, 305 mm** of, but not less than **3 in, 76 mm** from, the top of the enclosure. The bottom opening must be within **12 in, 305 mm** of, but not less than **3 in, 76 mm** from, the bottom of the enclosure.

Where directly communicating with the outdoors or communicating with the outdoors through vertical ducts, each opening shall have a minimum free area of **1 in<sup>2</sup>/4000 Btu/hr, 550 mm<sup>2</sup>/kW** of the total input rating of all of the equipment in the enclosure.

Where communicating with the outdoors through horizontal ducts, each opening shall have a minimum free area of **1 in<sup>2</sup>/2000 Btu/hr, 1100 mm<sup>2</sup>/kW** of the total input rating of all of the equipment in the enclosure.

When ducts are used, they must have the same cross-sectional area as the free area of the opening to which they connect.

When calculating the free area necessary to meet the make-up air requirements of the enclosure, consideration must be given to the blockage effects of louvers, grills and screens. Screens must have a minimum mesh size of **1/4 in, 6.4 mm**. If the free area through a louver or grill is not known, ducts should be sized per Table 2.

**Table 2 – Make-up Air Louver Sizing**

Input (MBH)	Required Cross Sectional Area					
	1/4 in 6.4 mm Wire Screen		75% Free Area Metal Louvers		25% Free Area Wooden Louvers	
	in <sup>2</sup>	cm <sup>2</sup>	in <sup>2</sup>	cm <sup>2</sup>	in <sup>2</sup>	cm <sup>2</sup>
500	125	806	167	1077	500	3226
750	187	1206	250	1613	750	4839
1000	250	1613	333	2148	1000	6452
1250	313	2019	416	2684	1250	8065
1500	375	2419	500	3226	1500	9677
1750	437	2819	583	3761	1750	11,290
1999	500	3226	667	4303	2000	12,900

Canadian installations must comply with CSA B149.1 when **air supply** is provided by natural air flow from the outdoors for **natural draft**, partial fan-assisted, fan-assisted, or power draft-assisted **burners**, there shall be a permanent **air supply** opening(s) having a cross-sectional area of not less than **1 in<sup>2</sup> per 7,000 Btu/h (310 mm<sup>2</sup> per kW)** up to **and including 1 million Btu/h, plus 1 in<sup>2</sup> per 14,000 Btu/h (155 mm<sup>2</sup> per kW) in excess of 1 million Btu/h.**

## Intake Air Option – General Guidelines

This configuration provides combustion air directly to the boiler/water heater's air intake using a dedicated pipe when using the direct vent option. The RBI air intake adapter must be fitted to the blower inlet. Combustion air can be drawn in horizontally through the same outside wall which terminates the exhaust gases or vertically through the roof, see Figures 1, 2, 3 & 4.

**WARNING: Common intake air systems may be used provided the common duct is sized properly and an intake combustion air damper is installed in the intake air pipe of each heater. Improper installation can result in excessive levels of carbon monoxide which can cause severe personal injury or death!**

Single wall galvanized smoke pipe, single wall aluminum pipe, flexible aluminum pipe, PVC or CPVC pipe can be used for the intake air pipe. It must be sized per Table 3.

**Table 3 - Intake Air Pipe Sizing**

Model Size	For Vertical		For Horizontal (Up To 60')	
	in	mm	in	mm
500	8	203	6	152
750	8	203	6	152
1000	8	203	6	152
1250	10	254	8	203
1500	10	254	10	254
1750	12	305	12	305
2000	12	305	12	305

All joints in metal intake air systems must be secured using corrosion resistant fasteners and sealed using a suitable Silicone caulk. If PVC or CPVC is used, the joints must be cleaned with a suitable solvent and connected using a solvent based PVC cement. **The combustion air system MUST be supported by the building structure not the boiler/water heater.**

# FUTERA FUSION INSTALLATION AND OPERATION INSTRUCTIONS

**CAUTION:** A combustion air damper interlocked with the unit should be installed in the intake air pipe when the infiltration of subfreezing air could occur, otherwise the unit could freeze up voiding the warranty!

## Intake Air Option – Vertical Guidelines

The maximum equivalent length for the vertical intake air pipe is **60 ft, 18.3 m**. Each 90° elbow and the intake air terminal are equal to **10 linear ft, 3.0 m** of pipe, see Table 3.

An approved, nonrestrictive intake air terminal must be used. The intake air terminal must terminate as shown in Figure 3. The penetration point in the roof must be properly flashed and sealed.

## Intake Air Option – Horizontal Guidelines

The maximum equivalent length for the horizontal intake air pipe is **60 ft, 18.3 m**. Each 90° elbow and the intake air terminal are equal to **10 linear ft, 3.0 m** of pipe. If horizontal runs exceed **5 ft 1.5 m** they must be supported at **3 ft, 0.9 m** intervals with overhead hangers. The certified intake air terminal from RBI must be used, see Figures 1, 2 and 4.

## GENERAL VENTING GUIDELINES

**WARNING:** The vent installation must be in accordance with Part 7, Venting of Equipment, of the National Fuel Gas Code, ANSI Z223.1/NFPA 54-latest revision or applicable provisions of the local building codes. Canadian installations must comply with CAN/CGA B149.1 or .2 Installation Code. Improper venting can result in excessive levels of carbon monoxide which can result in severe personal injury or death!

All vent systems must be fully supported by the building structure and not by the boiler/water heater. Appropriate thimbles and fire-stops must be used where required.

**WARNING:** Common vent systems must be properly engineered and sized, please contact the factory.

## VENT SYSTEM OPTIONS

The Futera Fusion may be vented the following ways:

- 1) **Direct Vent, Positive Pressure, Category IV** uses a vent system certified to UL 1738 for installations in the United States, ULC S636 for installations in Canada. Combustion air is piped from the outdoors to the blower inlet.
- 2) **Side Wall Vent, Positive Pressure, Category IV** uses a vent system certified to UL 1738 for installations in the United States, ULC S636 for installations in Canada. Combustion air is obtained from the space in which the unit is installed.
- 3) Must consult factory when venting single or multiple unit(s) over 60 equivalent feet. Mechanical system may be required.

**NOTE:** All venting, combustion air material supplied by installer.

## ANSI Categorization

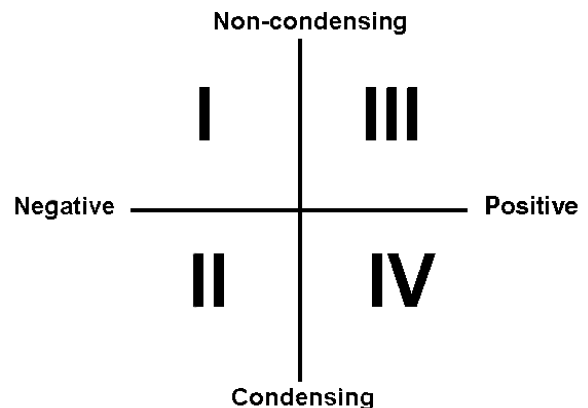

# FUTERA FUSION INSTALLATION AND OPERATION INSTRUCTIONS

## DIRECT VENT, POSITIVE PRESSURE, CATEGORY IV

In this configuration the boiler/water heater blower is used to push the flue products to the outdoors while drawing combustion air from the outdoors. The Intake Air Option instructions under the “COMBUSTION AIR & VENTILATION” section must be followed! The vent system must be sized per Table 4.

**Table 4 – Category IV**

Model Size	Pipe Diameter (Min.) (Up to 60')	
	in	mm
500	7	178
750	7	178
1000	7	178
1250	8	203
1500	8	203
1750	10	254
2000	10	254

### Horizontal Direct Vent Systems – Figures 1 & 2

The vent materials used in horizontal vent systems must be certified to UL 1738 for installations in the United States, ULC S636 for installations in Canada. The certified vent terminal from RBI must also be used.

The maximum equivalent length for the horizontal vent pipe is **60 ft, 18.3 m**. Each 90° elbow and the vent terminal are equal to **10 linear ft, 3.0 m** of pipe. If any part of a single wall metal vent system passes through an unheated space, it must be insulated with insulation rated for **400° F, 204°C**. Structural penetrations must be made using approved fire-stops. For best results, horizontal vent systems should be as short and straight as possible.

The vent system must be both gas tight and watertight. All seams and joints in metal pipes must be joined and sealed in accordance with the vent system manufacturer's instructions.

When horizontal vent runs exceed **5 ft, 1.5 m** they must be supported at **3 ft, 0.9 m** intervals with overhead hangers. The vent system must be pitched back, towards the secondary heat exchanger, **1/4 in/ft, 20 mm/m**. If any part of a single wall metal vent system passes through an unheated space it must be insulated with insulation rated for **400°F, 204°C**.

Horizontal vent systems shall terminate at least **4 ft, 1.2 m** below, **4 ft, 1.2 m** horizontally from or **1 ft, 0.30 m** above any door, window or gravity air inlet into any building. It must not terminate less than **4 ft, 1.2 m** horizontally from, and in no case above or below, unless a **4 ft, 1.2 m** horizontal distance is maintained, from electric meters, gas meters, regulators and relief equipment and not less than **7 ft, 2.1 m** from any adjacent public walkway. The bottom of the vent terminal(s) shall be located at least **5 ft, 1.5 m** above the air intake terminal(s) unless there is a minimum **5 ft, 1.5 m** horizontal separation between them. Avoid terminal locations likely to be affected by winds, snowdrifts, people and pets. Protect building materials and vegetation from degradation caused by the flue gases.

### Vertical Direct Vent Systems – Figure 3

If any part of a single wall metal vent system passes through an unheated space, it must be insulated with insulation rated for **400°F, 204°C**. Structural penetrations must be made using approved fire-stops.

An approved, nonrestrictive vent terminal must be used. The top of a vertical vent system must extend at least **5½ ft, 1.7 m** above the roof surface and maximum snow line that it passes through, **4 ft, 1.2 m** above the intake air terminal, see Figure 3.

In addition the vent system must conform to the dimensions shown in Figure 3. The penetration point in the roof must be properly flashed and sealed.

The vent system must be gas tight. All seams and joints in metal pipes must be joined and sealed in accordance with the vent system manufacturer's instructions.

### Combination Direct Vent Systems – Figure 4

The boiler/water heater can be vented vertically with the intake air piped horizontally through an outside wall. Follow the instructions in the Intake Air Option – Horizontal Guidelines. Also follow the general instructions in the “COMBUSTION AIR & VENTILATION” and “GENERAL VENTING GUIDELINES” sections.

# FUTERA FUSION INSTALLATION AND OPERATION INSTRUCTIONS

Figure 1– Horizontal Combustion Air and Venting for a Single Unit

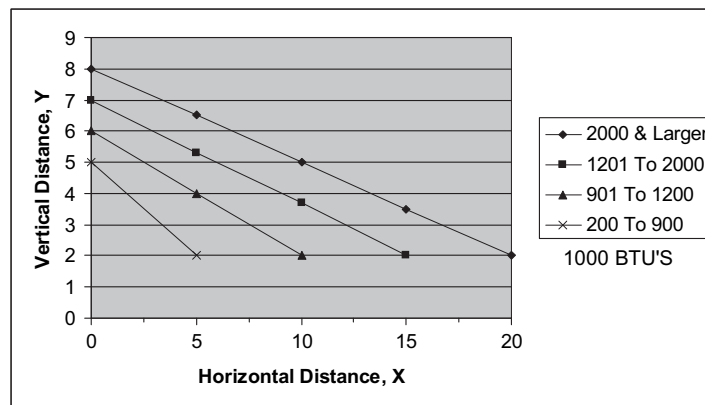
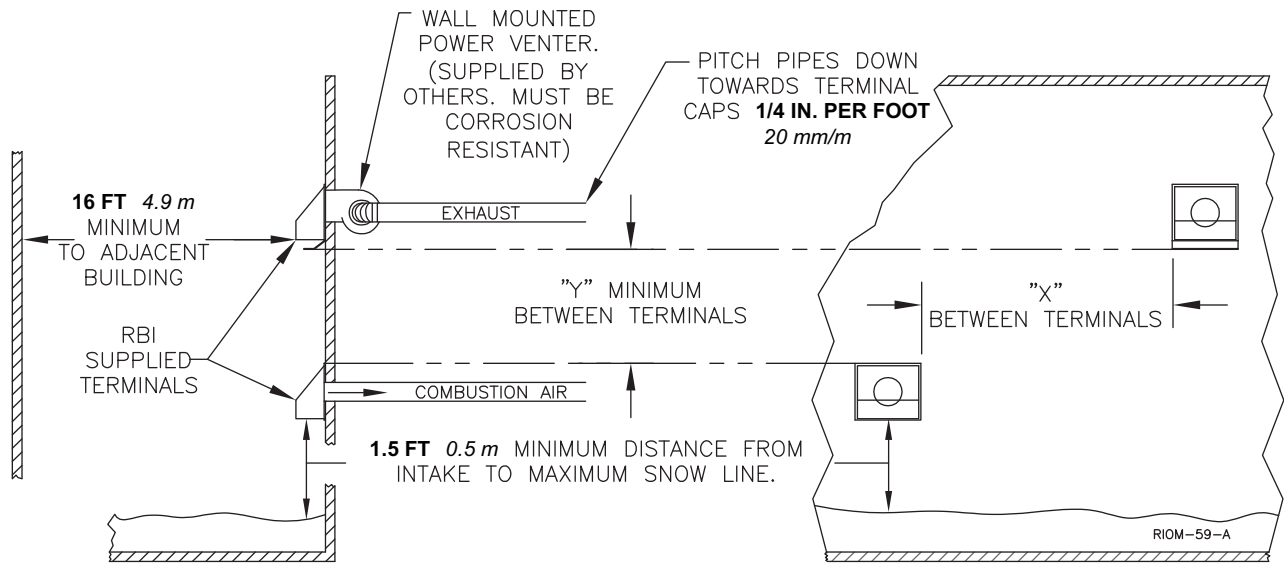

When running horizontal combustion air and venting for single or multiple units, exhaust and combustion air terminals must be installed on the same plane (outside wall) in order to prevent pressure differences due to prevailing winds. In cold climates, double-wall or insulated inlet pipe recommended to prevent condensation.

Figure 2 – Horizontal Combustion Air and Venting for Multiple Units

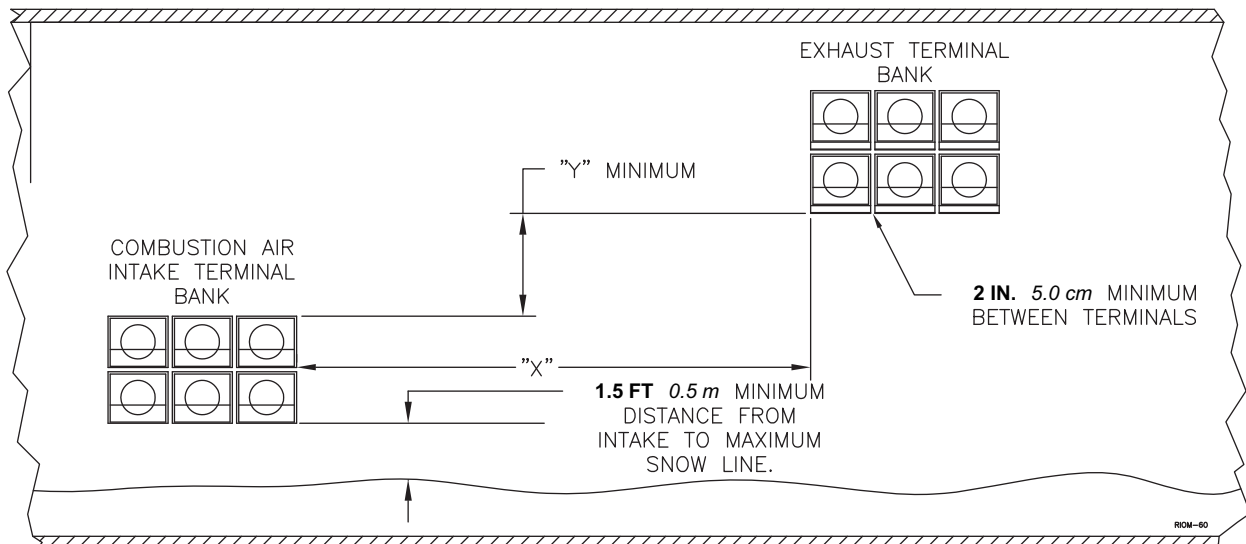

# FUTERA FUSION INSTALLATION AND OPERATION INSTRUCTIONS

Figure 3 - Vertical Air Intake and Venting for Direct Vent System

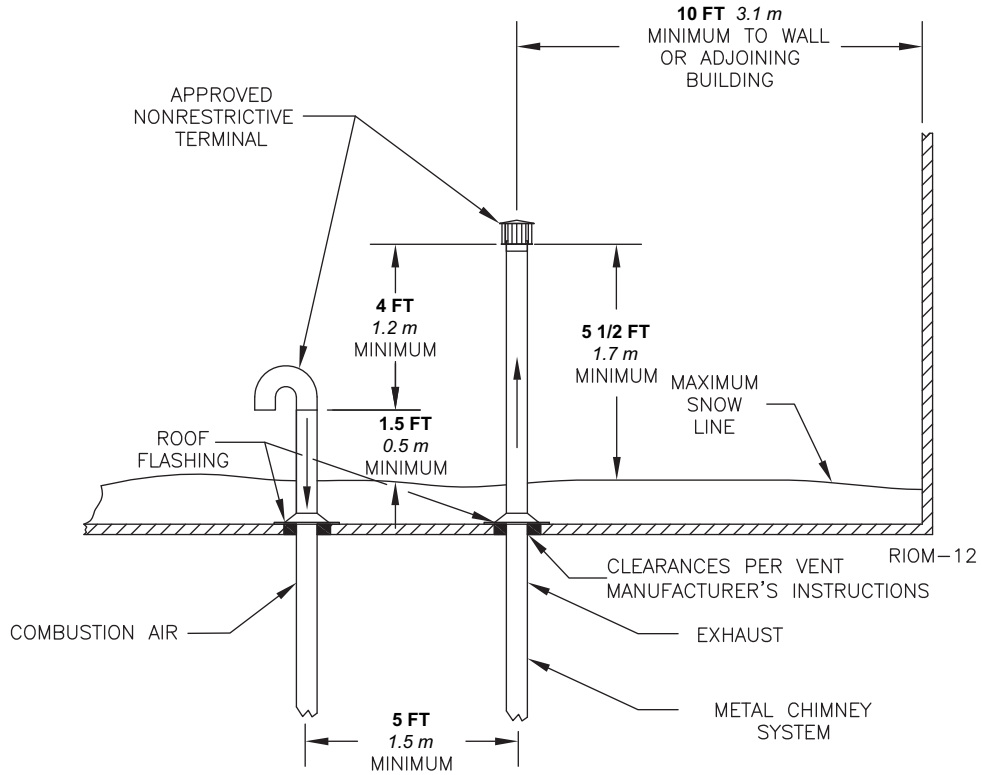
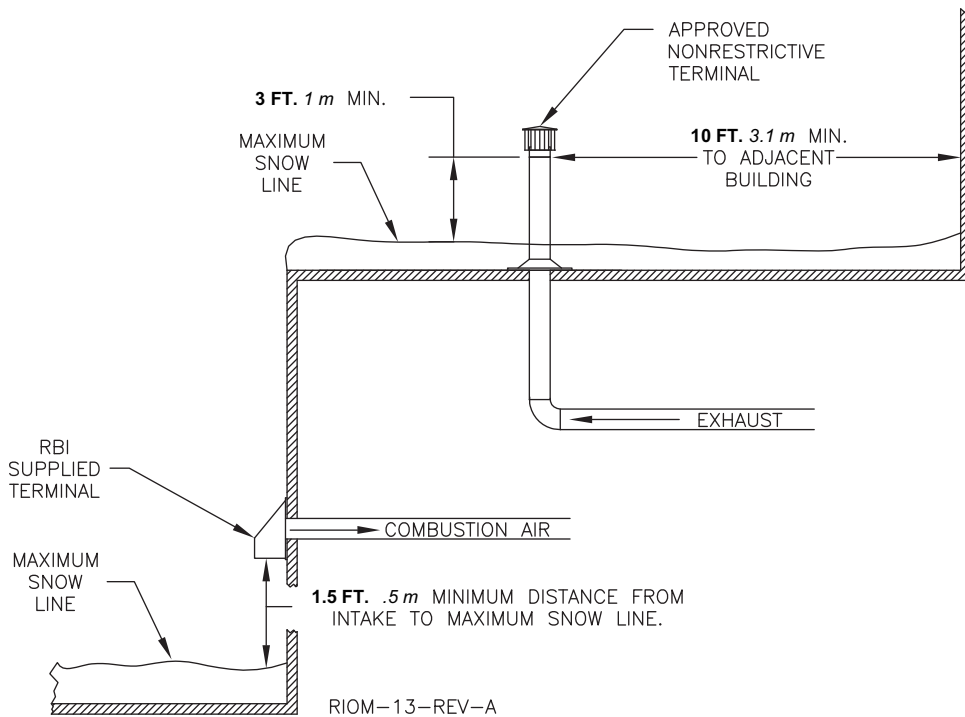

Figure 4 – Combination Direct Vent Systems



# FUTERA FUSION INSTALLATION AND OPERATION INSTRUCTIONS

## SIDE WALL VENT, POSITIVE PRESSURE, CATEGORY IV

In this configuration the boiler/water heater blower is used to push the flue products horizontally to the outdoors, see Figure 5. The air for combustion is taken from the space in which the unit is installed. The applicable instructions under the "COMBUSTION AIR & VENTILATION" section must be followed! The vent guidelines under the Horizontal Direct Vent Systems section must also be followed.

Figure 5 – Side Wall Venting

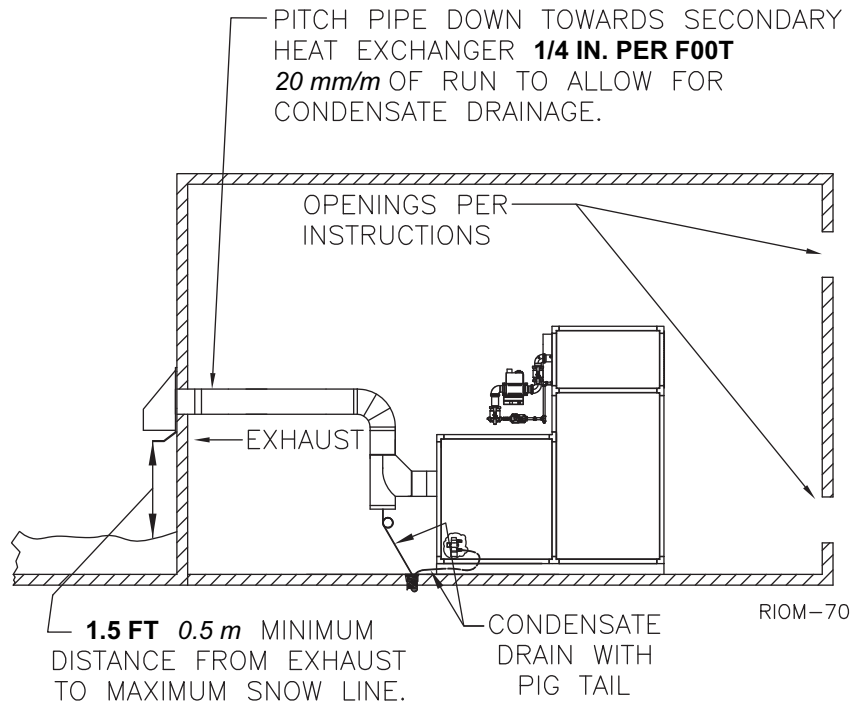

# FUTERA FUSION INSTALLATION AND OPERATION INSTRUCTIONS

Figure 6 – Vertical Venting with a Metal Chimney System

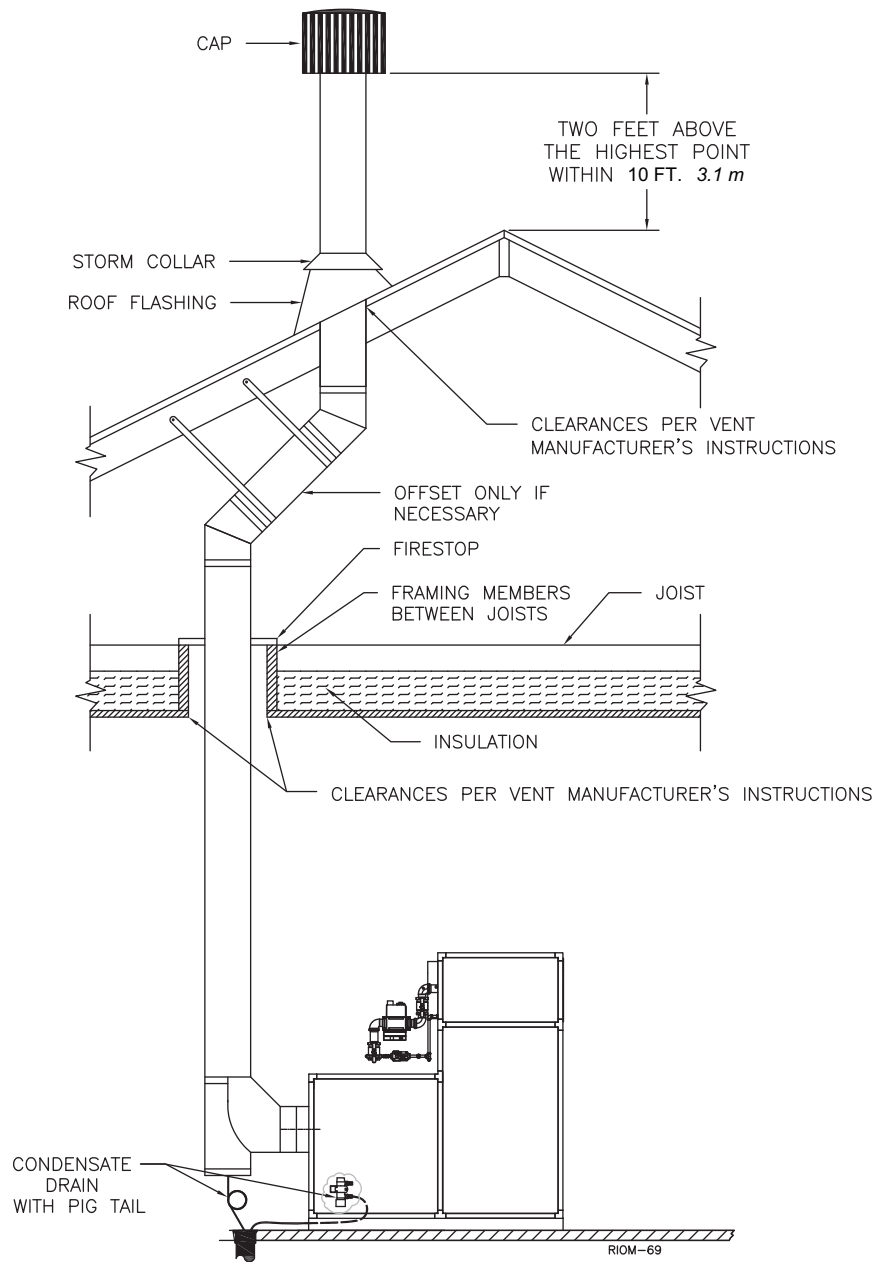

# FUTERA FUSION INSTALLATION AND OPERATION INSTRUCTIONS

## GENERAL PIPING REQUIREMENTS

**CAUTION: Improper piping of this boiler/water heater will void the manufacturer's warranty and can cause boiler failure resulting in flooding and extensive property damage! Excessive water hardness causing scaling in the copper heat exchanger tubes is NOT covered under the manufacturer's warranty, see Table 7. Excessive pitting and erosion of the internal surface of the copper heat exchanger tubes is NOT covered under the manufacturer's warranty if the result of high water flow rates, see Table 7.**

**NOTE: Shut off valves and unions should be installed at the inlet and outlet connections of the boiler/hot water heater to provide for isolation of the unit should servicing be necessary.**

### Freeze Protection

Installations in areas where the danger of freezing exists are not recommended unless proper freeze protection is provided. The following precautions MUST be observed:

1. A continuous flow of water through the unit MUST be maintained! The pump responsible for flow through the boiler/water heater must run continuously!
2. An ethylene glycol/water mixture suitable for the minimum temperature that the unit will be exposed to must be used. The pump must be capable of producing a minimum of 15% more flow and overcoming a 20% increase in head loss. Domestic water systems must be isolated from the water heater by the use of a heat exchanger or other approved method.
3. If the unit must be shut off for any reason the electric, gas and water supplies MUST be shut off and the unit and its pump completely drained.

### Condensate Piping

The condensate trap provided with the boiler must be attached to the bottom pan and piped to a suitable floor drain or condensate pump. If a condensate neutralization device is installed, it must be positioned prior to boiler room drain. Condensate fill trap must be maintained with fluid.

### Relief Valve

Pipe the discharge of the pressure relief valve as shown in Figure 8.

**WARNING: Never install any type of valve between the boiler/water heater and the relief valve or an explosion causing extensive property damage, severe personal injury or death may occur!**

### Flow Switch

The flow switch supplied with the boiler/water heater must be wired to the terminal strip in the control panel to prevent the boiler from firing unless there's adequate water flow through the unit. The flow switch must be installed in the supply piping adjacent to the boiler outlet connection.

**CAUTION: Failure to properly install the flow switch may result in damage to the boiler/water heater heat exchanger voiding the warranty!**

## HEATING SYSTEM PIPING

### General Piping Requirements

All heating system piping must be installed by a qualified technician in accordance with the latest revision of the ANSI/ASME Boiler and Pressure Vessel Code, Section IV, and ANSI/ASME CSD-1, Standard for Controls and Safety Devices for Automatically Fired Boilers. All applicable local codes and ordinances must also be followed. A minimum clearance of **1 in, 25 mm** must be maintained between heating system pipes and all combustible construction. All heating system piping must be supported by suitable hangers not the boiler. The thermal expansion of the system must be considered when supporting the system. A minimum system pressure of **12 psig, 82.7 kPa** must be maintained.

### Heating Boiler Piping Connections

The supply and return connections should be sized to suit the system, see Table 6.

**Table 6 – Supply & Return Pipe Sizing**

Model Size	Supply Size	Return Size
500 thru 1000	2" NPT	2" NPT
1250 thru 2000	2 1/2" NPT	2 1/2" NPT

### Pump Requirements

This low mass boiler requires a continuous minimum water flow for proper operation. The system pump must be sized to overcome the head loss of the boiler and the heating system in order to achieve the required temperature rise. Table 7 provides the heat exchanger pressure drop and temperature rise figures. The temperature rise across the boiler must never exceed **35°F, 19.4°C**. The adjustable pump delay turns the pump on each time the burner fires and runs the pump for 20 to 600 seconds after the call for heat is satisfied.

# FUTERA FUSION INSTALLATION AND OPERATION INSTRUCTIONS

Figure 8 – Futera Fusion Piping

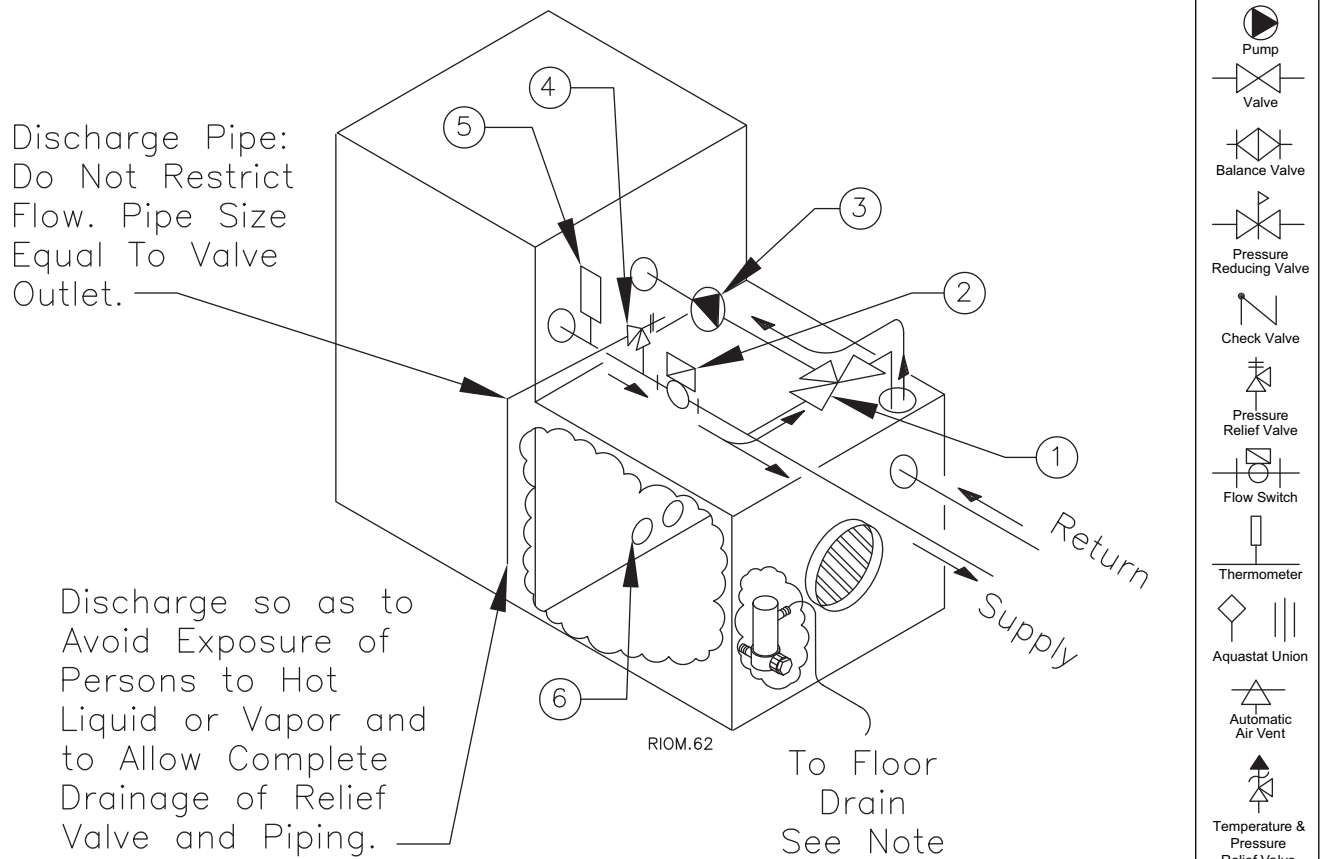

**NOTE:**

Fill condensate drain trap with water or approved anti-freeze solution prior to start-up.

Item Number	Description
1	3-Way Valve
2	Flow Switch
3	Circulator
4	Pressure Relief Valve
5	T&P Gauge
6	Primary Heat Exchanger Drain Valves
7	Condensate Drain Trap

# FUTERA FUSION INSTALLATION AND OPERATION INSTRUCTIONS

**CAUTION: A temperature rise outside of the range listed in Table 7 indicates that the flow rate through the heat exchanger is incorrect which will damage the heat exchanger voiding the warranty! The maximum allowable temperature rise is 35°F, 19.4°C.**

The maximum allowable flow rate through a Futera Fusion boiler is 97 GPM, 6.1 L/s on 500 through 1000 models and 136 GPM, 8.6 L/s for 1250 through 2000 models. The Cupro-Nickel heat exchanger allows for 108 GPM, 6.8 L/s on 500 through 1000 models and 151 GPM, 9.5 L/s on 1250 through 2000 models.

**Table 7 - Temperature Rise Table**

		$\Delta T = 15^{\circ}\text{F}$		$\Delta T = 8.3^{\circ}\text{C}$	
Model Number	Flow Rate GPM	Total Loss* Ft	Flow Rate L/s	Total Loss* kPa	
500	58.0	8.8	3.7	26.3	
		$\Delta T = 20^{\circ}\text{F}$		$\Delta T = 11.1^{\circ}\text{C}$	
Model Number	Flow Rate GPM	Total Loss* Ft	Flow Rate L/s	Total Loss* kPa	
750	65.3	10.5	4.1	31.4	
1250	108.8	11.6	6.9	34.7	
		$\Delta T = 25^{\circ}\text{F}$		$\Delta T = 13.9^{\circ}\text{C}$	
Model Number	Flow Rate GPM	Total Loss* Ft	Flow Rate L/s	Total Loss* kPa	
750	52.2	7.7	3.3	23.0	
1250	87.0	8.2	5.5	24.4	
1500	104.4	11.6	6.6	34.7	
1750	121.8	14.7	7.7	43.9	
		$\Delta T = 30^{\circ}\text{F}$		$\Delta T = 16.7^{\circ}\text{C}$	
Model Number	Flow Rate GPM	Total Loss* Ft	Flow Rate L/s	Total Loss* kPa	
1000	58.0	9.5	3.7	28.4	
1500	87.0	8.5	5.5	25.4	
1750	101.5	10.6	6.4	31.7	
2000	116.0	13.8	7.3	41.2	

\*Includes primary, secondary, mixing valve and piping.

## Low Water Cutoff

If a boiler is installed above any radiation elements it must be fitted with a low water cutoff device.

Refer to the wiring diagram supplied with the boiler/water heater for proper wiring connections.

## Expansion Tank & Air Separator

An expansion tank or other means to control thermal expansion must be installed in the heating system. An expansion tank must be installed close to the boiler on the suction side of the pump. An air scoop and automatic air vent must also be installed to eliminate air trapped in the system.

## Primary/Secondary Piping

Figure 9 shows a typical primary/secondary piping system. Boilers connected to heating systems using zone valves, zone pumps, or systems that have excessive flow rates must be isolated from these systems to protect the boiler.

## Multiple Boiler Systems

Systems using multiple boilers can also be installed using a primary/secondary manifold system, Figure 11.

## Piping For Use With Cooling Units

The boiler, when used in connection with a refrigeration system, must be installed so the chilled medium is piped in parallel with the boiler. Appropriate valves must be used to prevent the chilled water from entering the boiler.

When a boiler is connected to a heating coil that may be exposed to refrigerated air from an air handling device, the piping system must be equipped with flow-control valves or some other automatic means of preventing gravity circulation of the boiler water during the cooling cycle.

# FUTERA FUSION INSTALLATION AND OPERATION INSTRUCTIONS

**Figure 9 - Typical Primary/Secondary, Low Temperature Piping System**  
(See Notes)

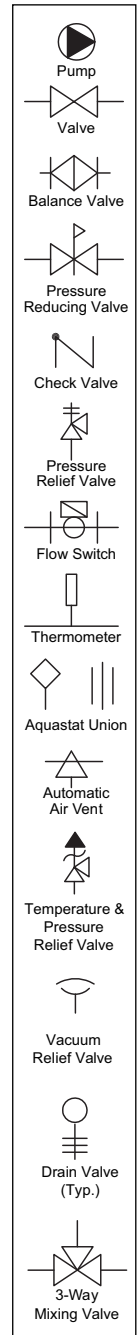
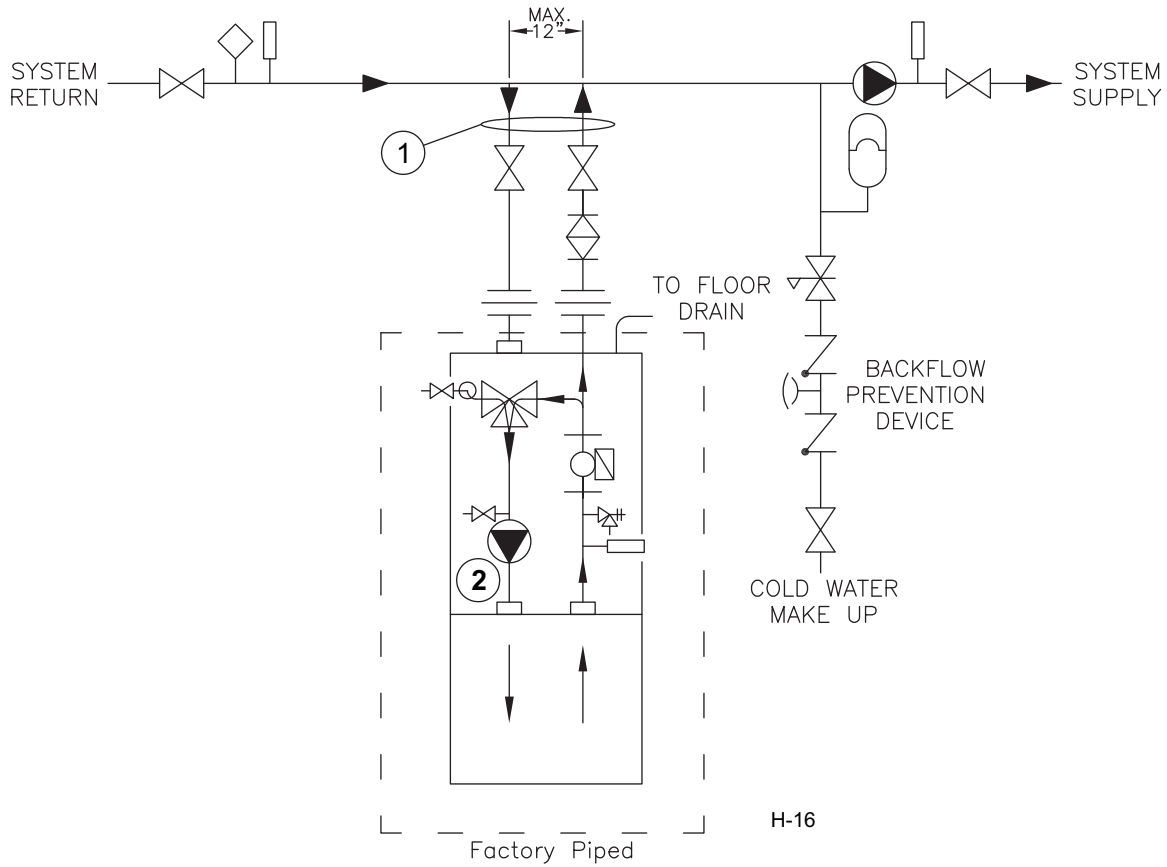

**NOTES:**

1. Boiler circuit piping must be sized large enough to handle maximum flow through unit.
2. **Boiler and pump purging required. Air must be purged from 3-way valve after the boiler is filled. Use purge valves provided. Purge valve may be located on pump flange. On multiple boiler installations the flow switch may fail due to trapped air. See manual for procedure.**
3. All boilers furnished with factory mounted outlet water temperature gauge.

Notice: These drawings show suggested piping configuration and valving. Check with local codes and ordinances for specific requirements.

# FUTERA FUSION INSTALLATION AND OPERATION INSTRUCTIONS

Figure 11 - Multiple Boiler Piping (See notes)

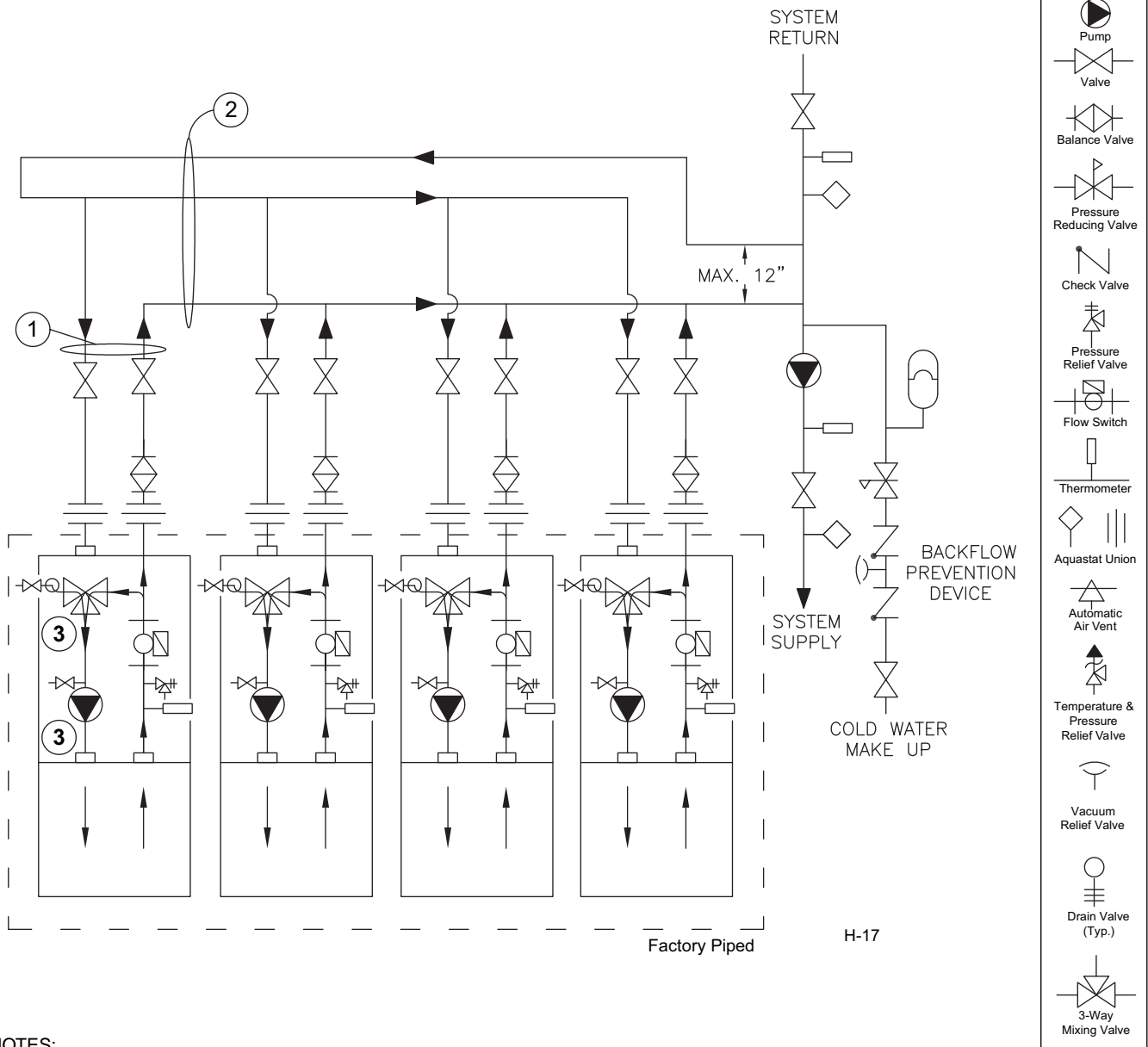

**NOTES:**

1. Boiler circuit piping must be sized large enough to handle maximum flow through each unit.
2. System loop pipe diameter must be sized large enough to handle maximum flow through all units.
3. **Boiler and pump purging required. Air must be purged from 3-way valve after the boiler is filled. Use purge valves provided. Purge valve may be located on pump flange. On multiple boiler installations the flow switch may fail due to trapped air. See manual for procedure.**
4. All boilers furnished with factory mounted outlet water temperature gauge.
5. Condensate lines on each unit should be connected for a floor drain.

Notice: These drawings show suggested piping configuration and valving. Check with local codes and ordinances for specific requirements.

# FUTERA FUSION INSTALLATION AND OPERATION INSTRUCTIONS

## DOMESTIC WATER SUPPLY PIPING

**CAUTION: Proper controls must be used to prevent water supplied for domestic use from exceeding 130°F, 54°C or a scald injury will occur! When higher water temperatures are required for appliances such as a dishwasher, a mixing valve or some other tempering means must be installed. Households with small children may require water temperatures less than 120°F, 49°C. Local codes must be complied with!**

### General Piping Requirements

Ensure that the water heater is equipped with bronze headers. Piping and components connected to the water heater must be suitable for use with potable water. The water heater must not be connected to any heating system piping or components previously used with a non-potable water heating appliance. No toxic chemicals, such as those used for boiler treatment, are to be introduced into the potable water used for space heating. If a hot water storage tank is used in the system it must be equipped with a temperature and pressure relief valve that complies with ANSI Z21.22 or CAN-4.4 and CAN-4.6.

**NOTE: The storage tank must be located as close to the water heater as possible to prevent excessive head loss which will reduce flow.**

### Bleed Air From Boiler

Open the water heater piping bleed valves one at a time, to purge the air trapped in the primary and secondary heat exchangers. Refer to piping drawings (Figures 12 & 13) for bleed locations.

### Water Chemistry

The required temperature rise across the water heater is based on water having a hardness between 8 and 18 grains per gallon with a level of dissolved solids not exceeding 350 ppm. Water having a hardness less than 8 grains can cause excessive corrosion of the heat exchanger. Water that has a hardness greater than 18 grains per gallon and/or a level of dissolved solids exceeding 350 ppm will require a recalculation of the pump size and temperature rise.

A cupro-nickel heat exchanger may also be required. The manufacturer should be consulted when these water conditions are encountered. See Table 8A.

**CAUTION: The maximum allowable flow rate through a Futera Fusion water heater is 97 GPM, 6.1 L/s on 500 through 1000 models and 136 GPM, 8.9 L/s for 1250 through 2000 models. The cupro-nickel heat exchanger allows for 108 GPM, 6.8 L/s on 500 through 1000 models and 151 GPM, 9.5 L/s on 1250 through 2000 models.**

RBI water heaters are designed to run scale free. Due to the extreme variables of water conditions world wide it is necessary to consider pH values and water hardness in relationship to scaling. It is crucial to consider these two variables when making heat exchanger and pump selections. If local water conditions are extreme, follow the guidelines in the Heat Exchanger Selection Table (Table 8A). Scale free operation can be achieved by using water with a hardness between 8 and 18 and by maintaining the pH between 5 and 9. Follow the conditions listed under NORMAL in the table. In some areas of the country additional precautions must be observed due to unusual characteristics of the local water supply. Call the nearest RBI representative for details.

### Expansion Tank

An expansion tank or other means to control thermal expansion must be installed in the water heating system if back flow prevention devices are installed.

### Pump Requirements

This low-mass water heater requires a continuous minimum water flow for proper operation. The proper velocity through the water heater must be maintained in accordance with Table 7 for efficient operation and long life. If the temperature rise through the water heater is lower than recommended the water velocity is too high. Premature erosion of the heat exchanger will occur. Conversely, if the temperature rise is higher than recommended in Table 7 the flow rate is too low. Scaling and softening of the heat exchanger will occur. **The temperature rise across the water heater must never exceed 35°F, 19.4°C.**

**Storage Tank Thermostatic Mixing Valve – Water Above 140°F, 60°C** Water can be stored at temperatures above 140°F, 60°C provided that a thermostatically controlled mixing valve is used to temper the hot water to an acceptable temperature before it's supplied for domestic use.

The mixing valve **MUST** be set to prevent a scald injury from occurring, see the caution against scalding.

Storage of water for domestic use above 140°F, 60°C will provide an increased quantity of tempered water and help prevent the growth of water born bacteria.



# FUTERA FUSION INSTALLATION AND OPERATION INSTRUCTIONS

**Figure 12 - Typical Water Heating Piping (CW Models Only)**

(See Notes)

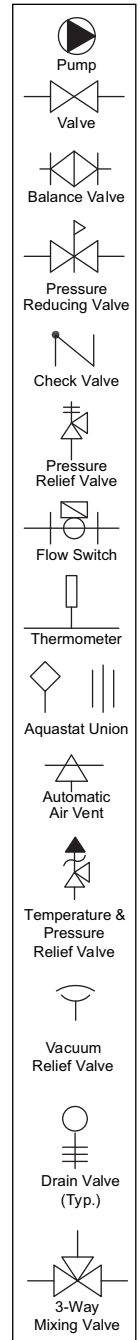
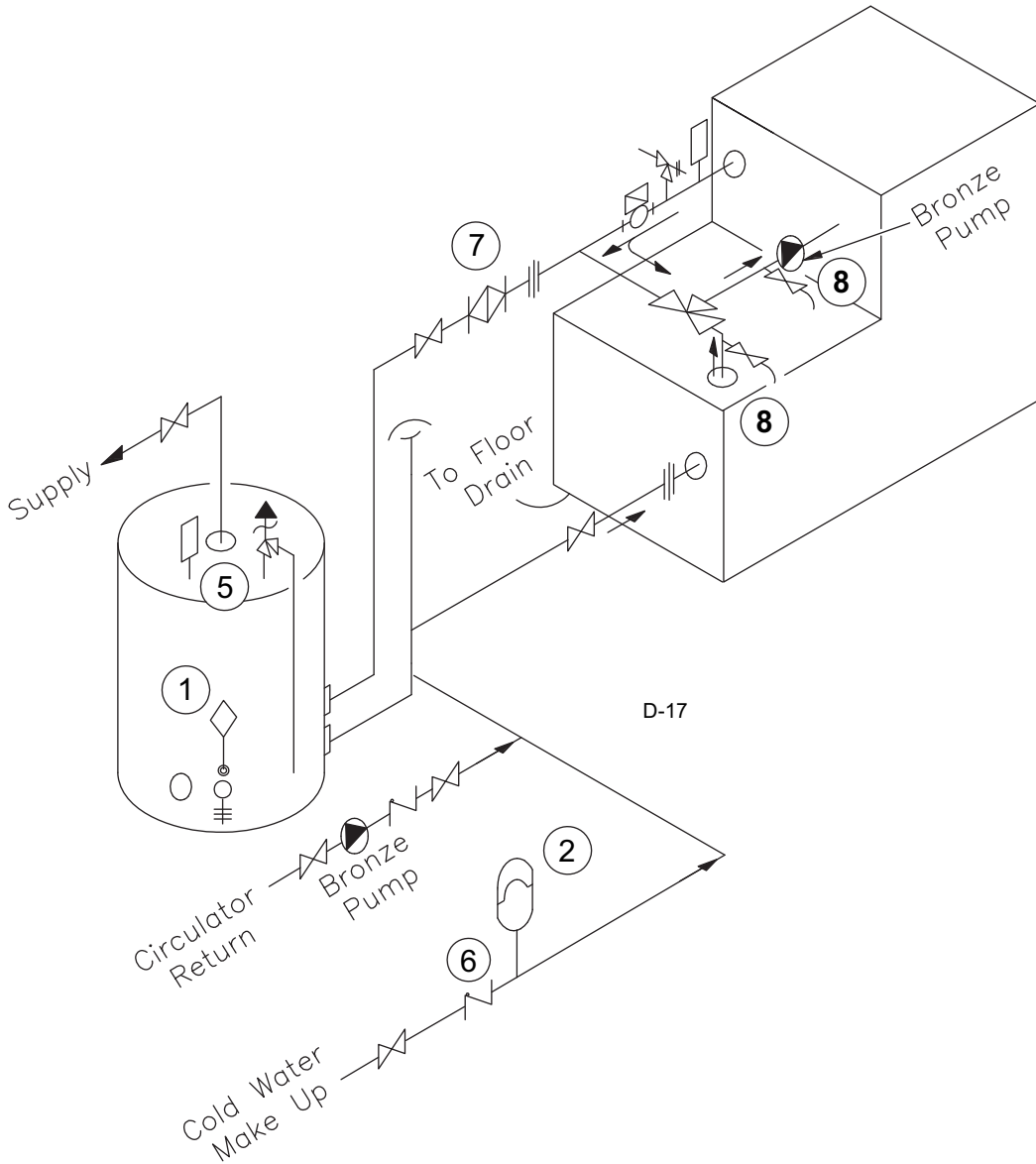

**NOTES:**

1. When using intermittent pump and pump delay, locate remote aquastat well in lower 1/3 of tank. Install aquastat with heat sensing compound.
2. Thermal expansion tank may be required, check local codes.
3. CAUTION: MEASURE WATER HARDNESS AND pH AT JOB SITE.  
Be sure to specify when ordering the pH and water hardness. This must be measured before selecting heat exchanger and pump. Consult the Heat Exchanger Graph and Pumping Performance Table before making selection.
4. Common piping must be sized for maximum combined heater flow.
5. Hot water tanks should be equipped with a combination temperature & pressure relief valve.
6. MA Code requires an 1/8" hole in check valve to compensate for thermal expansion.
7. Use balance valve to set the temperature rise through the boiler. (Delta T)
8. **Boiler and pump purging required. Air must be purged from 3-way valve after the boiler is filled. Use purge valves provided. Purge valve may be located on pump flange. On multiple boiler installations the flow switch may fail due to trapped air. See manual procedure.**

Notice: These drawings show suggested piping configuration and valving. Check with local codes and ordinances for specific requirements.

# FUTERA FUSION INSTALLATION AND OPERATION INSTRUCTIONS

**Figure 13 - Multiple Water Heating Piping (CW Models Only)**  
(See Notes)

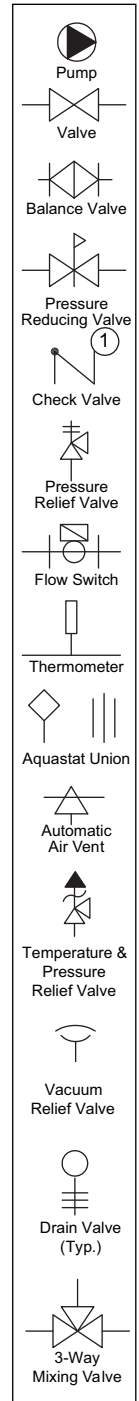
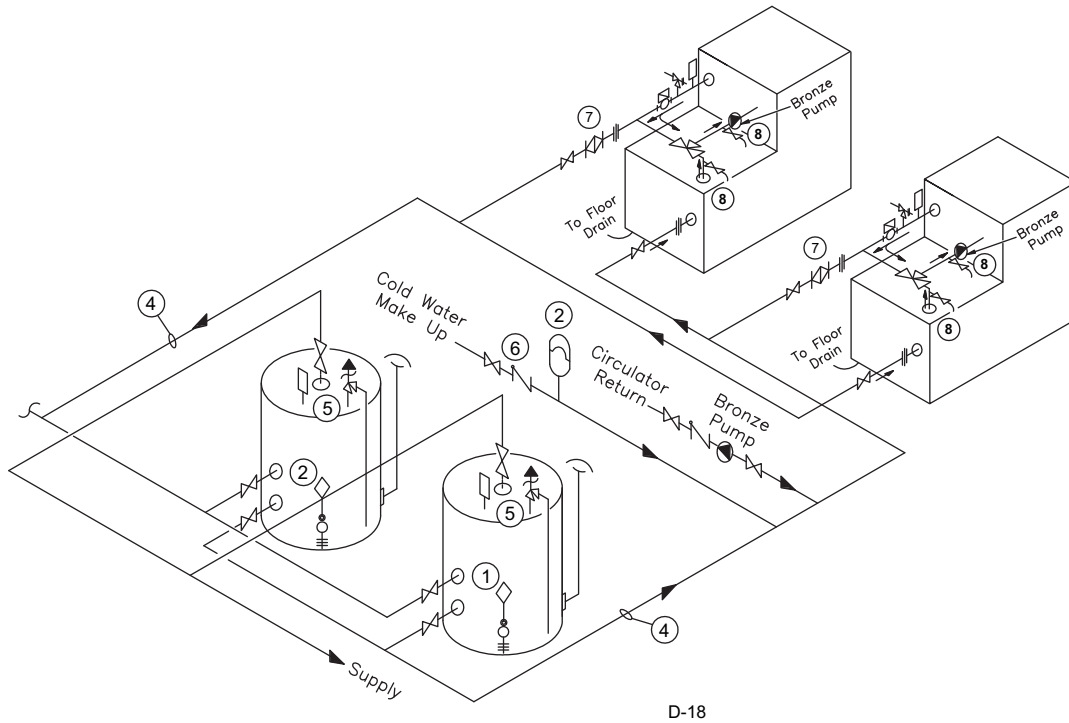

**NOTES:**

1. When using intermittent pump and pump delay, locate remote aquastat well in lower 1/3 of tank. Install aquastat with heat sensing compound.
2. Thermal expansion tank may be required, check local codes.
3. **CAUTION: MEASURE WATER HARDNESS AND pH AT JOB SITE.**  
Be sure to specify when ordering the pH and water hardness. This must be measured before selecting heat exchanger and pump. Consult the Heat Exchanger Graph and Pumping Performance Table before making selection.
4. Common piping must be sized for maximum combined heater flow.
5. Hot water tanks should be equipped with a combination temperature & pressure relief valve.
6. MA Code requires an 1/8" hole in check valve to compensate for thermal expansion.
7. Use balance valve to set the temperature rise through the boiler. (Delta T)
8. **Boiler and pump purging required. Air must be purged from 3-way valve after boiler is filled. Use purge valves provided. Purge valve may be located on pump flange. On multiple boiler installations the flow switch may fail due to trapped air. See manual procedure.**

Notice: These drawings show suggested piping configuration and valving. Check with local codes and ordinances for specific requirements.

# FUTERA FUSION INSTALLATION AND OPERATION INSTRUCTIONS

## GAS SUPPLY PIPING

**WARNING: Check the boiler/water heater rating plate to make sure that the boiler/water heater is for the type of gas that will be used. If it isn't, do not connect the boiler/water heater to the gas supply. Gas supply piping must be in accordance with the National Fuel Code, ANSI Z223.1-latest revision or applicable provisions of the local building codes. Canadian installations must comply with CAN/CGA B149.1 or .2 Installation Code. Failure to comply with this warning can result in extensive property damage, severe personal injury or death!**

The Futera Fusion comes from the factory ready to be piped to the gas supply. If for any reason the boiler/water heater is not for the type of gas available at the installation site, call your RBI representative to resolve the problem.

**NOTE: A minimum gas supply pressure of 2 in, 51 mm, W.C. natural or propane and maximum 14 in, 356 mm W.C. natural or propane, must be available at the safety shutoff valve inlet with the unit(s) operating.**

Table 9 should be used to ensure that the gas supply piping is sized properly. If more than one appliance is supplied by the same supply pipe, the piping must be sized based on the maximum possible demand. Do not neglect the pressure drop due to pipe fittings. Table 9 should be used in conjunction with Table 10 to ensure that the gas supply piping has the capacity to meet the demand.

Figure 14 depicts the proper way to connect the boiler/water heater to the gas supply piping. The manual shutoff valve **MUST** be installed in the supply piping. It should be installed **5 ft, 1.5 m** above the floor where required by local codes. Provide a sediment trap at the bottom of the vertical section of the gas supply pipe upstream of the gas controls.

A ground joint union should be installed between the boiler gas controls and the supply piping. Each of these items are needed to ensure long life and ease of servicing. Always use a pipe sealant that is suitable for use with LP gas.

**Table 9 – Gas Pipe Capacity**

Maximum pipe capacity in ft <sup>3</sup> /hr based on 0.60 specific gravity gas at a pressure of 0.5 psig or less and a 0.3" WC pressure drop.									
Nominal Iron Pipe Size, (in)	Pipe length in feet								
	10	20	30	40	50	60	80	100	150
Maximum gas volume of pipe, (ft <sup>3</sup> /hr)									
1"	520	350	285	245	215	195	170	150	120
1 1/4"	1050	730	590	500	440	400	350	305	250
1 1/2"	1600	1100	890	760	670	610	530	460	380
2"	3050	2100	1650	1270	1120	1000	890	770	630

Note: Multiply the gas volume by 0.62 for propane flow capacity in ft<sup>3</sup>/hr. Multiply the propane flow capacity by 2500 Btu/ft<sup>3</sup> to determine the propane Btu/hr capacity for a given pipe size and length.

**Table 10 – Equivalent Pipe Length Chart**

Nominal Iron Pipe Size, (in)	Type of pipe fitting			
	90° Elbow	Tee <sup>1</sup>	Gate Valve <sup>2</sup>	Gas Cock <sup>2</sup>
Equivalent pipe length, (ft)				
1"	2.6	5.2	0.6	1.5
1 1/4"	3.5	6.9	0.8	1.9
1 1/2"	4.0	8.0	0.9	2.3
2"	5.2	10.3	1.2	3.0

Notes: 1. For flow through branch.  
2. For flow at full open.

**Figure 14 – Gas Supply Piping**

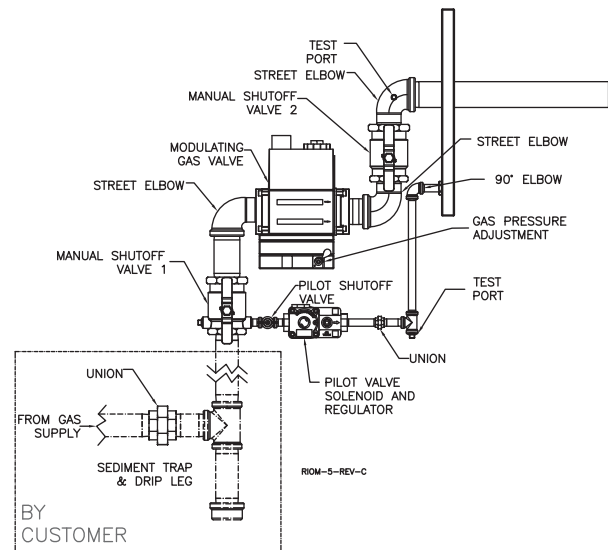

**CAUTION: Always use a wrench on the gas valve body when making gas connections to it. Never over-tighten the piping entering the gas valve body or gas valve failure may result!**

When applicable, provisions for vent, bleed and gas relief lines must be made in accordance with the latest revision of ANSI Z223.1/NFPA 54. The main Dungs gas valve supplied with the boiler/water heater does not require external venting.

Safe lighting and other performance criteria were met with the gas manifold and control assembly provided on the boiler. All gas connections **MUST** be leak tested before putting the boiler into operation.

# FUTERA FUSION INSTALLATION AND OPERATION INSTRUCTIONS

**WARNING: Never use an open flame to test for gas leaks. Always use an approved leak detection method. Failure to comply with this warning can cause extensive property damage, severe personal injury or death!**

Whenever the gas supply piping is pressure tested the boiler/water heater gas controls must be protected. If the test pressure is equal to, or less than **1/2 psig, 3.5 kPa** isolate the boiler/water heater by closing its manual shut off valve, see Figure 14. If the test pressure is greater than, or equal to **1/2 psig, 3.5 kPa**, disconnect the boiler/water heater and its individual shut-off valve.

## ELECTRICAL WIRING

### Electrical Power Connections

**CAUTION: Label all wires prior to disconnection when servicing controls. Wiring errors can cause improper and dangerous operation! Verify proper operation after servicing.**

**ATTENTION: Au moment de l'entretien des commandes, étiquetez tous les fils avant de les débrancher. Des erreurs de câblage peuvent entraîner un fonctionnement inadéquat et dangereux. S'assurer que l'appareil fonctionne adéquatement une fois l'entretien terminé.**

The electrical connections to this boiler/water heater must be made in accordance with all applicable local codes and the latest revision of the National Electrical Code, ANSI/NFPA-70. Installation should also conform with CSA C22.1 Canadian Electrical Code Part I if installed in Canada.

Install a separate 120 volt 15 amp circuit for the boiler/water heater. A properly rated shut-off switch should be located at the boiler/water heater. The boiler/water heater must be grounded in accordance with the authority having jurisdiction, or if none, the latest revision of the National Electrical Code, ANSI/NFPA-70.

Line voltage field wiring of any controls or other devices must conform to the temperature limitation of type T wire at **95°F, 35°C** above room temperature. Use copper conductors with a minimum size of #14 awg.

Refer to the wiring diagram supplied with the boiler/water heater for proper wiring connections.

## GENERAL OPERATION

**WARNING: Before proceeding read and fully understand the instructions contained in this manual. Do not attempt to operate this boiler/water heater if it has not been installed in accordance with the guidelines set forth in this manual. Failure to comply with this warning can result in extensive property damage, severe personal injury or death!**

Should overheating occur or the gas supply fail to shut off, turn off the manual gas control valve to the appliance. Do not interrupt water flow through the boiler/water heater.

En cas de surchauffe ou si l'alimentation en gaz ne s'arrête pas, fermez manuellement le robinet d'arrêt de l'admission de gaz.

### Hydronic Heating Boilers (Fill System)

Open the make-up water valve and slowly fill the boiler and all of the radiation with water. Ensure that all bleed and drain valves are closed.

Adjust the make-up water pressure regulator so a minimum **12 psig, 82.7 kPa** system pressure is maintained at the highest point in the system piping. If a make-up water pump is used adjust it to maintain a minimum **12 psig, 82.7 kPa** system pressure.

**Open the boiler piping bleed valves one at a time, to purge the air trapped in the primary and secondary heat exchanger. Refer to piping drawings (Figures 9 & 11) for bleed locations.**

With the boiler off, run the system pump for at least 30 minutes and bleed the system piping using the bleed valves. If strainers are used in the system piping, the make-up water valve should be closed and the strainers checked and cleaned.

The system expansion tank should be checked to ensure that the correct water level in the tank is maintained. The tank should be less than half full of water with the system full and adjusted to the correct operating pressure.

Start the boiler as described in the "OPERATING INSTRUCTIONS" section. Run the boiler for at least an hour. The system pump(s) and all radiation units must be operated during this time. Ensure that the make-up water valve is open.

Shut the boiler off and open the bleed valves to purge the air trapped in the heating system piping. Close the make-up water valve and check and clean the strainers and make-up water pressure reducing valve.

Open the make-up water valve and adjust the system pressure if necessary. The system should be checked and bled after three days of operation.

# FUTERA FUSION INSTALLATION AND OPERATION INSTRUCTIONS

## OPERATING INSTRUCTIONS

FOR YOUR SAFETY READ BEFORE OPERATING.

### POUR VOTRE SÉCURITÉ LISEZ AVANT DE METTRE EN MARCHÉ

- A. This appliance is equipped with an ignition device which automatically lights the pilot. Do not try to light the pilot by hand.

Cet appareil est muni d'un dispositif d'allumage qui allume automatiquement la veilleuse. Ne tentez pas d'allumer la veilleuse manuellement.

- B. BEFORE OPERATING smell all around the appliance area for gas. Be sure to smell next to the floor because some gas is heavier than air and will settle on the floor.

**DANGER: Propane gas may not always be detected by smell. Propane gas is heavier than air and can collect in low areas.**

**Propane gas can ignite or explode if an ignition source is present and result in death, serious injury and property damage!**

#### FOR YOUR SAFETY

- Have only qualified licensed professionals install, service and maintain this appliance and your gas system in accordance with all applicable codes.
- If you suspect a leak:
  1. Have everyone leave the building immediately.
  2. Do not attempt to light any appliance.
  3. Do not touch any electrical or electronic switches in the building.
  4. Do not use any phone in the building.
  5. Call your gas supplier from a phone outside of the building.
  6. If you cannot reach your gas supplier call the fire department.

AVANT DE FAIRE FONCTIONNER, reniflez tout autour de l'appareil pour déceler une odeur de gaz. Reniflez près du plancher, car certains gaz sont plus lourds que l'air et peuvent s'accumuler au niveau du sol.

#### QUE FAIRE SI VOUS SENTÉZ UNE ODEUR DE GAZ:

- Ne pas tenter d'allumer d'appareil.
- Ne touchez à aucun interrupteur; ne pas vous servir des téléphones se trouvant dans le bâtiment.
- Appelez immédiatement votre fournisseur de gaz depuis un voisin. Suivez les instructions du fournisseur.
- Si vous ne pouvez rejoindre le fournisseur, appelez le service de incendies.

- C. Do not use this appliance if any part has been under water. Immediately call a qualified service technician to inspect the appliance and to replace any part of the control system and any gas control that has been under water.

N'utilisez pas cet appareil s'il a été plongé dans l'eau, même partiellement. Faites inspecter l'appareil par un technicien qualifié et remplacez toute partie du système de contrôle et toute commande qui ont été plongés dans l'eau.

**CAUTION: To prevent being burned, stand clear of the boiler during ignition and don't touch any hot metal parts!**

## Operating Instructions

1. **STOP!** Read the safety information above. If, at any time, the appliance will not operate properly, follow the instructions "TO TURN OFF GAS TO APPLIANCE".
2. Set the operating control to off or its lowest setting.
3. Turn off all electric power to the appliance.
4. Close manual main shut-off valves 1 and 2 and the pilot gas shut-off valve, Figure 14.
5. Make sure that the gas supply piping has been purged of air and that all gas joints up to the gas valve have been thoroughly checked for leaks.

Wait five (5) minutes to clear out any gas. Then smell for gas, including near the floor. If you smell gas, **STOP!** Follow "B" in the safety information above (to the left) on this label. If you don't smell gas, go to the next step.

6. Power appliance and turn the power switch on the side of the boiler to "on". If all interlocks are properly closed, the display will say "Standby Futera Fusion". If this is not the case refer to the "DIAGNOSTICS" section for further information.
7. A minimum gas supply pressure of **2 in, 51 mm**, W.C. natural of propane and max **14 in, 356 mm** W.C., natural of propane, must be available at the safety shutoff valve inlet with the unit(s) operating.
8. Create a full input demand by jumping the AA terminals on control board at terminal strip J12.
9. The boiler will begin the start sequence.

# FUTERA FUSION INSTALLATION AND OPERATION INSTRUCTIONS

10. Monitor the flame current on the Honeywell Burner Control 7897C. No flame current should be detected and the 7897C should lock out. If flame current is detected at any time up to the 7897C locking out, the 120V wiring on the ignition transformer must be reversed. Test again to insure that no flame is detected.

**WARNING: Improper wiring of the ignition transformer can result in an explosion causing extensive property damage, severe personal injury or death!**

11. Open the manual main shut-off valves 1 and 2 and the pilot gas shut-off valve, Figure 14.
12. Reset the Honeywell 7897C. The boiler will begin the start sequence.
13. When the main display reads "PILOT RUNNING" and the flame current is 5 VDC, switch the Honeywell 7897C to the "test" position. This will hold the Honeywell 7897C in its ignition state.
14. Adjust the pilot pressure per the "CHECKING & ADJUSTMENTS".
15. Switch the Honeywell 7897C back to "run".
16. Allow the boiler to establish main flame and modulate to full input. Check the input rate per the "CHECKING & ADJUSTMENTS" section.
17. Move the slide switch below the display to "Min Hold", low fire.
18. Set manifold pressure at elbow before entering cabinet to -2.95" WC ( $\pm$  -1.1" WC) at high fire.
19. Allow the boiler to modulate to min input. Observe the burner to ensure that it is not operating in an infrared condition. Take a flue gas sample using a calibrated analyzer. Use a 2.5mm, 3/32" allen wrench to adjust the gas valve to produce a CO<sub>2</sub> of approximately 8.5% for natural gas and 10.5% for propane. Make small 10-degree adjustments and wait until the CO<sub>2</sub> readings settle before making further adjustments.
20. When all adjustments are finished, move the slide switch below the display to the "Run" position and remove input by opening jumper AA.
21. The boiler allows for four modes of operation. Refer to the "MPA STAGING CONTROL" for further information.

## Consignes d'utilisation

1. **ATTENTION!** Lisez les mises en garde ci-dessus. Si vous constatez une anomalie quelconque dans le fonctionnement de l'appareil, suivez les instructions de la section «COMMENT COUPER L'ALIMENTATION DE GAZ DE L'APPAREIL».

2. Mettez l'appareil à l'arrêt ou réglez celui-ci au minimum.
3. Coupez toute alimentation électrique de l'appareil.
4. Fermez manuellement les robinets d'arrêt principaux 1 et 2 ainsi que le robinet d'arrêt de la veilleuse. Voir figure 14.
5. Assurez-vous au préalable que la conduite d'alimentation en gaz a été purgée et que tous ses raccords jusqu'au niveau du robinet sont exempts de fuite.
6. Mettez l'appareil sous tension et tournez l'interrupteur situé sur le côté de la chaudière en position de marche. Si tous les interrupteurs de verrouillage sont convenablement fermés, l'affichage doit indiquer «Standby Futera Fusion». Si ce n'est pas le cas, reportez-vous à la section «DIAGNOSTIC».
7. Lorsque l'appareil est en marche, la pression du gaz à l'entrée du robinet d'arrêt de sécurité doit être au minimum de **2 po, 51 mm, CE**, gaz naturel ou propane et au maximum de **14 po, 356 mm, CE**, gaz naturel ou propane.
8. Créez une nette demande de chauffage au tableau de commandes en posant un cavalier sur les bornes AA (bornier J12).
9. La chaudière entamera la séquence de démarrage.
10. Surveillez le courant de flamme sur le régulateur du brûleur Honeywell 7897C. Aucun courant de flamme ne doit être détecté et le 7897C devrait se verrouiller. Si un courant de flamme est détecté avant le verrouillage du 7897C, le câblage 120V du transformateur d'allumage doit être inversé. Vérifiez à nouveau pour vous assurer qu'aucune flamme n'est détectée.

**AVERTISSEMENT: Un câblage incorrect du transformateur d'allumage peut provoquer une explosion entraînant de graves blessures ou la mort et causer d'importants dégâts matériel.**

11. Ouvrez manuellement les robinets d'arrêt principaux 1 et 2 ainsi que le robinet d'arrêt de la veilleuse. Voir figure 14.
12. Remettez à zéro le régulateur Honeywell 7897C. La chaudière commencera la séquence de démarrage.
13. Lorsque l'affichage indique «PILOT RUNNING» et que le courant de flamme est de 5V c.c., commutez le Honeywell 7897C en mode «test». Ceci permettra de le maintenir en position d'allumage.
14. Réglez la pression de la veilleuse tel qu'indiqué à la section «VÉRIFICATION ET RÉGLAGES».
15. Commutez à nouveau le Honeywell 7897C en mode «marche».

# FUTERA FUSION INSTALLATION AND OPERATION INSTRUCTIONS

16. Laisser la chaudière compléter la séquence d'allumage et atteindre son plein régime. Vérifiez le débit tel qu'indiqué à la section «VÉRIFICATION ET RÉGLAGES».
17. Déplacez le curseur situé sous l'écran d'affichage, à la position «Min Hold», soit faible régime.
18. Laissez la chaudière atteindre son régime minimum. Observez le brûleur et vérifiez qu'il ne fonctionne pas en infrarouge. Prélevez un échantillon de gaz de combustion à l'aide d'un analyseur calibré. Réglez le robinet de gaz au moyen d'une clé Allen de 2,5mm (3/32 po) afin de produire une concentration de CO<sub>2</sub> d'environ 8,5% pour du gaz naturel et de 10,5% pour du gaz propane. Procédez par écarts de 10 degrés et attendez que la lecture du CO<sub>2</sub> se stabilise avant chaque nouveau réglage.
19. Lorsque tous les réglages ont été effectués, glissez le curseur situé sous l'écran d'affichage à la position «Run» et mettez fin à la demande en retirant le cavalier des bornes AA.
20. La chaudière offre quatre modes d'opération. Reportez-vous à la section «MPA STAGING CONTROL» pour plus de détails.

## To Turn Off Gas To Appliance

1. Set the operating control or thermostat to its lowest setting.
2. Turn off all electric power to the appliance if service is to be performed.
3. Close the manual main and pilot gas shut-off valves.

## COMMENT COUPER L'ADMISSION DE GAZ DE L'APAREIL

1. Réglez le thermostat à la température la plus basse.
2. Coupez l'alimentation électrique de l'appareil s'il faut procéder à l'entretien.
3. Fermer la vanne manuelle d'arrêt d'alimentation de gaz.

## CHECKING & ADJUSTMENTS

### Spark Gap

With the main and pilot gas manual valves in the closed position energize the unit. Observe the trial for ignition to confirm that the spark is strong and continuous. If not check and adjust the spark gap as shown in Figures 15 & 16.

Figure 15 – Spark Gap

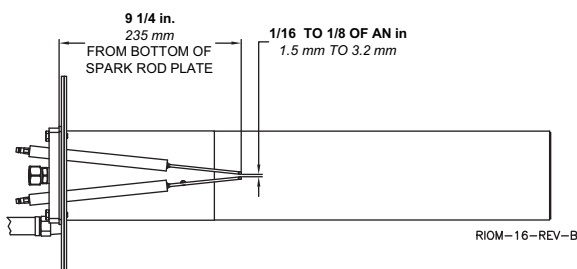
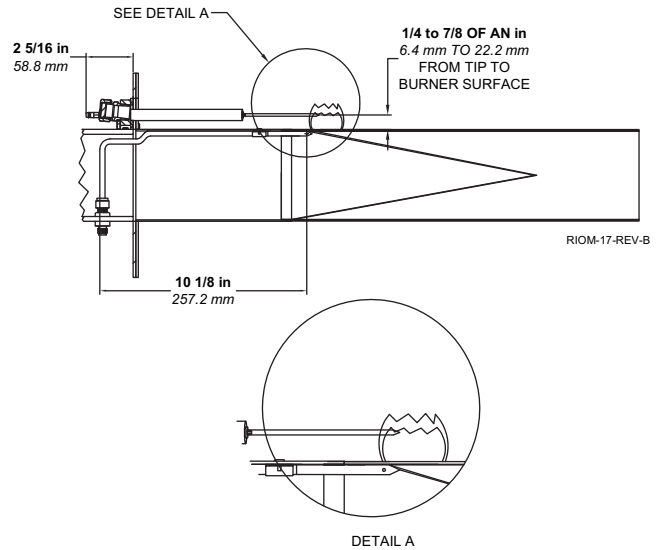

Figure 16 – Spark Rod Position and Pilot Flame



### Pilot Adjustment

The pilot pressure has been factory set at 2" and shouldn't need adjustment. To check the pilot pressure close the manual main shut-off valve 2 and the pilot gas shut-off valve, Figure 14. Remove the 1/8" pipe plug from the pilot tee and connect a manometer having a minimum range of 6 in, 152 mm WC to it. Open the pilot gas shut-off valve. With the unit powered, generate a call for heat. When the pururge is complete the ignition/pilot trial will begin. At this point put the Honeywell 7897C test switch in the test position. The control will hold in the ignition/pilot sequence allowing you to check the pressure.

### To adjust the pilot the following steps must be taken:

1. Remove the pilot gas pressure regulator cap.
2. Turn the pressure regulator adjustment screw clockwise to increase the pressure and counterclockwise to decrease it.
3. Replace the pressure regulator adjustment screw cap.

**CAUTION: Never force the regulator adjustment screw beyond the stop limits or damage to the regulator will occur!**

**WARNING: The air damper adjustment must only be made by a trained technician using a combustion analyzer! Improper adjustment can result in excessive levels of carbon monoxide or an explosion resulting in severe personal injury or death!**

# FUTERA FUSION INSTALLATION AND OPERATION INSTRUCTIONS

## Required Gas Pressure

Provide gas supply pressure at inlet to boiler gas train as follows:

	LP	Nat
Minimum (in W.C.)	2	2
Maximum (in W.C.)	14	14

Measure pressure when the boiler is firing at full rate. Low gas pressure could indicate undersized gas line or insufficient gas supply.

“Static and operating gas pressure required at the gas valve inlet is between 2" W.C. and 14" W.C. for natural gas and 2" W.C. and 14" W.C. propane. If the gas pressure is above this limit, a lock-up style regulator suitable for dead end service such as an Equimeter or Fisher must be installed to prevent increase (creep) of gas pressure when the units are not operating. This pressure regulator (supplied by others) may be installed at the service entrance to each unit or a “master” regulator sized to handle multiple units may be utilized. Consult local gas utility or regulator manufacturer for recommendations to meet specific job site requirements.”

## Input Rate, Natural Gas

Gas appliances are rated based on sea level operation with no adjustment required at elevations up to **2000 ft, 610 m**. At elevations above **2000 ft, 610 m** input ratings should be reduced by 4% for each **1000 ft, 305 m**.

Check the input rate as follows:

1. Turn off all other gas appliances that use the same gas meter as the boiler/water heater.
2. Call your gas supplier and ask for the heating value of the gas.
3. Start the boiler/water heater and let it run for 15 minutes.
4. Using the gas meter and a stopwatch, clock the time that it takes to burn **10 ft<sup>3</sup>, 0.28 m<sup>3</sup>** of gas and divide this time by 10.
5. Insert the heating value and the time, in seconds, into the formula below.
6.  $\text{Input} = (\text{heating value, Btu/hr})(3600)/(\text{time, seconds})$
7. If the computed rate deviates by more than 5% from the rated input value of the unit, consult factory.

**CAUTION: Never increase the input to the boiler/water heater above that for which it is rated. Doing so can cause premature failure of the boiler!**

## CONTROL DESCRIPTION

### Low Water Cutoff

If the boiler is to be installed above radiation or if required by other codes or regulations, install a low water cutoff in appropriate piping. Wire the switch and any external controls in series to the "Interlock" contacts in the junction box (see the attached Connection Diagrams for details). Ensure that the low water cutoff device(s) will function properly.

## Operating Control

The preferred control setting for potable hot water is **130°F, 54°C**. The operating control should be set to the lowest setting that will satisfy the consumer's needs.

**WARNING: Setting the thermostat or operation control too high can result in scalding resulting in severe personal injury!**

## High Limit (Aquastat)

The high limit is located in the top control area of the boiler/water heater. A remote capillary bulb is run to a well on the outlet side of the supply header. The high limit can be reset by depressing the red button.

The water heater high limit should be set a minimum of **20°F, 11°C** higher than the operating control. Refer to the HOT WATER SUPPLY section for the proper supply water temperature.

## Flow Switch

A flow switch is provided in the water outlet piping to prevent the boiler/water heater from firing without adequate water flow through the heat exchanger.

## MPA STAGING CONTROL

This boiler control is mounted on the front panel of the boiler/water heater. It utilizes various temperature sensors to calculate boiler/water heater demand and adjust the modulation as needed. Various features of the control can be adjusted from the 3-button panel on the controller. To change settings of the modulation controller, press and hold all three buttons approximately 2 seconds until the “adjust” screen appears, then release them. The modulating control provides 4 modes of operation based on the requirements of the system. Each mode is defined below.

At the rear of the controller, there is a single DIP switch. This switch is factory set to provide a “lockout” with minimum adjustment capabilities in the field. However, for experienced installers and operators, changing these switch settings can offer many fine-tuning features. Please consult the factory for assistance.

**CAUTION: DO NOT change DIP switch or controller settings unless you have completely read and understood this document and the control manufacturer's instructions. Doing otherwise will lead to improper modulating control.**

# FUTERA FUSION INSTALLATION AND OPERATION INSTRUCTIONS

## Installer Level Settings

**Modes of Operation (MODE):** The control allows for four modes of operation in order to define the control operation and piping arrangement used.

*Mode 1: Setpoint Control. Parallel Piping.* The Futera Fusion is piped in parallel with the system. The rate of modulation is controlled to provide a setpoint temperature at the boiler/water heater outlet, whenever there is a heat demand present.

*Mode 2: Setpoint Control. Primary/Secondary Piping.* The Futera Fusion is piped in a primary/secondary configuration. An additional system sensor is required to properly control the system supply (primary loop) temperature. The rate of modulation is controlled to provide the setpoint temperature in the primary loop.

*Mode 3: Domestic Hot Water (DHW) generation.* The Futera Fusion is piped in parallel with the storage tank. An additional sensor is required to monitor the tank temperature. The rate of modulation is controlled to maintain the desired DHW tank temperature.

*DHW Operation:* A DHW demand is generated whenever the temperature sensed by the DHW sensor drops below the programmed tank target temperature by 1/2 the tank differential, adjustable from 2 to 10°F. The demand remains until the temperature sensed by the DHW sensor rises above the programmed tank target temperature plus 1/2 the tank differential.

*Mode 4: External Boiler Control:* The Modulating Boiler Control allows for an external boiler control to operate the boiler. Factory installed terminals are supplied inside the front cabinet of the Futera Fusion. These include boiler start contacts, 4-20mA modulating signal contacts, and boiler alarm dry contacts. A sequencer or controller must provide both boiler start contacts and a modulating signal for external control of the boiler/water heater. The modulating boiler control will display inlet and outlet temperatures as well as control the pump delay.

### **Boiler Target Temperature (BOIL TARGET)**

The boiler target temperature is determined from the mode of operation. The control displays the temperature that it is currently trying to maintain at the operating sensor as BOIL TARGET in the View menu. The operating sensor for mode 1 is the outlet sensor. Mode 2 is the system supply sensor. Mode 3 is the tank sensor. There is no boiler target temperature generated in mode 4.

### **Boiler Differential (BOIL DIFF)**

The boiler is operated with a differential in order to reduce short cycling. The boiler differential is divided around the boiler target temperature. The control will initiate the boiler/water heater when the operating sensor is 1/2 of the differential setting below the boiler target temperature, and will stop the boiler/water heater once the modulating output is at the minimum modulation setting and the water temperature at the operating sensor is 1/2 of the differential setting above the boiler target temperature.

### **Boiler Purge (PMP DLY)**

After a demand is satisfied, the control continues to operate the boiler pump for a period of time. The length of time that the boiler pump continues to run is based on the PMP DLY setting. Once the boiler turns off, the control keeps the boiler pump running for the time selected. This setting allows purging of any excess heat out of the boiler after the boiler is shut off.

When PMP DLY is set to OFF, there is no purging. When PMP DLY is set to ON, the pump runs continuously.

### **Tank Target Temperature (TANK TARGET), Mode 3 Only**

The TANK TARGET setting is used to set the desired DHW tank temperature.

### **Tank Differential (TANK DIFF), Mode 3 Only**

A differential setting that operates 1/2 above and below the TANK TARGET is selectable using the TANK DIFF item in the Adjust menu.

## Advanced Level Settings

**CAUTION: These settings are not to be changed unless the manufacturer is contacted. Unstable or even dangerous operation of the boiler/water heater could result.**

**Motor Speed:** The control includes a motor speed adjustment, which sets the speed of the actuating motor that provides firing modulation. Default value is 30.

**Start Modulation:** The start modulation is the firing rate recommended for proper burner ignition. Default value is 4%.

**Minimum Modulation:** The minimum modulation is the firing rate the control will modulate down to during operation. This setting is based on the analog output signal, which provides low fire. Default value is 0%.

**Fire Delay:** The fire delay is the time that the control waits at the Start Modulation output. The delay is the result of a pre-purge and trial ignition built into the boiler's safety circuits. Default value is 20 sec.

**Boiler Mass:** The boiler mass setting allows the installer to adjust the control to the thermal mass of different types of heat sources used. The boiler mass setting automatically determines the rate of modulation. A higher thermal mass setting provides slower modulation, while a lower thermal mass provides faster modulation. Default value is 1.

**Boiler Minimum:** The boiler minimum is the lowest water temperature that the control is allowed to use as a boiler target temperature. For boiler operation the default value is 140°F. For domestic hot water operation the default value is 120°F.

**Boiler Maximum:** The boiler maximum is the highest water temperature that the control is allowed to use as a boiler target temperature. The default value is 210°F.

# FUTERA FUSION INSTALLATION AND OPERATION INSTRUCTIONS

## DIAGNOSTICS

The Futera Fusion has a display that indicates the sequence of operation. The display will also list faults should the unit fail to operate. An explanation of each status message and fault is listed below.

**STANDBY FUTERA FUSION:** Indicates that power is being supplied to the unit and there is no call for heat.

**STANDBY START DEMAND:** Indicates that the boiler has a call for heat and that all safety limits have proved.

**STANDBY REMOTE DISABLED:** Indicates that the boiler start interlock is open. This usually indicates that either a building management system or a remote thermostat has disabled the boiler.

**PREPURGE:** The boiler performs a 10 second fan pre-purge to push out any gases that might still be in the combustion chamber before the boiler fires.

**PILOT RUNNING:** This is displayed during the pilot flame establishing period.

**MAIN MODULATION:** This indicates when the boiler has successfully established a pilot flame and the main valve has opened. The screen will also display the rate of modulation as a percentage.

**POSTPURGE:** The boiler performs a 10 second fan post-purge to push out any gases that are still in the combustion chamber after the flame is extinguished.

**HONEYWELL ALARM:** Indicates that there is a call for heat and the Honeywell Burner Control is locked out. Either it is locked out due to a flame failure, or it is malfunctioning. Press the reset button on the Burner Control.

**LOCKOUT HIGH LIMIT:** Indicates that the high limit controller has opened due to a high outlet water temperature. To reset press the red button on the high limit controller inside the upper cabinet. The high limit should be set at least 20°F above the target temperature for the boiler.

**LOCKOUT AIR FLOW:** Indicates that there is inadequate airflow through the boiler. Check the air filter for debris, or for any materials obstructing the flue outlet. Check the blocked flue switch, it may have to be reset.

**LOCKOUT GAS PRESSURE:** Indicates that either the low gas or high gas pressure switches have opened. These switches are manual reset.

**LOCKOUT WATER LIMIT:** Indicates that the water flow switch is not proving adequate water flow through the boiler or the low water cutoff is sensing low water.

**LOCKOUT HI-LIMIT & WATER LIMIT:** Indicates that both the high-limit and water limit interlocks are open.

**LOCKOUT HI-LIMIT & GAS PRESSURE:** Indicates that both the high-limit and gas pressure interlocks are open.

**MULTIPLE INTERLOCK:** Indicates that there are more than 2 interlocks that are open. Check the high-limit, gas pressure switches, and water flow switch.

**LOCKOUT TEKTRA ALARM:** Indicates a problem with the RBI Modulating Control. This is usually the result of a short or open circuit in one of the temperature sensors. Inspect the sensor in question to see if it is connected properly. Also, check to see if the sensor is shorted or open using an ohmmeter.

## MAINTENANCE

**WARNING: Disconnect electrical power and close the manual gas shut off valve before performing maintenance or severe personal injury may result!**

**CAUTION: Servicing, inspection and adjustment must be done by a trained technician in accordance with all applicable local and national codes. Improper servicing or adjustment can damage the boiler/water heater!**

The boiler/water heater must be cleaned and inspected at least once a year and before each heating season. Make sure that the burner and ignition components are free from dust, soot, dirt, corrosion or other deposits that would impair the boiler/water heater 's performance. Refer to page 31 and 32 for component identification.

**CAUTION: Improper burner servicing can result in premature burner failure voiding the warranty!**

### Burner Removal

1. Close the manual shutoff valves in the gas supply line and turn off electrical power to the boiler/water heater.
2. Remove the jacket top panel.
3. Disconnect the wires to the fan and remove the four bolts that secure the fan to the transition piece.
4. Remove wires from the spark rods and remove the UV sense from the transition piece.
5. Disconnect the compression nut at the back of the transition piece to remove pilot gas tubing.
6. Remove the four nuts holding the transition piece to the heat exchanger.
7. Lift and remove the transition piece and burner together from the boiler/water heater, taking care not to damage the spark rods and or their alignment.
8. Disconnect the compression nut from the inside of the transition piece.
9. Remove the transition piece, taking care not to damage the spark rods and or their alignment.

### Heat Exchanger Inspection

1. Close the manual shutoff valves in the gas supply lines and turn off electrical power to the boiler/water heater.
2. Remove burner following the instructions in the **Burner Removal** section.
3. Remove the front jacket panel and combustion chamber door.
4. Inspect the inside and outside of the heat exchanger for signs of damage, sooting or corrosion.

# FUTERA FUSION INSTALLATION AND OPERATION INSTRUCTIONS

- The outside surfaces of the copper tubes should be free of any soot deposits. A slight black smudge is normal with some types of gases. Black soot indicates poor combustion. Green deposits indicate condensation due to low return water temperatures. Water returned to the water heater inlet must not be less than **125°F, 52°C** or excessive condensation of the products of combustion will damage the water heater voiding the warranty. In either case the heat exchanger must be cleaned thoroughly and the problem resolved before the boiler/water heater is returned to service.
- If there are no signs of damage, sooting or corrosion, reassemble the unit following the previous steps in reverse order.
- A badly corroded or damaged heat exchanger must be replaced, see the **Heat Exchanger Repair & Replacement** section.

## Heat Exchanger Cleaning

- Close the shut off valves in the inlet and outlet piping. On heating systems close the system fill valve and relieve the system pressure from the boiler by carefully lifting the relief valve or opening the drain valve.
- Disconnect the boiler/water heater from the system piping.
- Remove the eight bolts on the rear pipe enclosure panel.
- Remove the front jacket panel and combustion chamber door.
- Slide the heat exchanger out of the unit.
- Remove the "V" baffle straps and "V" baffles.
- Thoroughly clean the heat exchanger with water from a high-pressure hose. Use a soft bristle brush if necessary.
- Replace the cleaned heat exchanger and other components in the reverse order of their removal.

## Heat Exchanger Repair & Replacement

- A leaking or otherwise damaged tube(s) can be replaced as outlined in steps 2 through 8.
- Remove the heat exchanger from the boiler/water heater as outlined in the **Heat Exchanger Cleaning** section.
- Remove the pipe plugs from the inlet/outlet and return headers opposite from the ends of the tube(s) being replaced.
- Carefully cut the damaged tube(s) in half, taking care not to damage the adjacent tubes and remove.
- Install and swage/expand in place the new tube(s).
- Replace the pipe plugs using a suitable thread sealant on each one.
- Sagging or distorted heat exchanger tubes are an indication of low water flow through the system. A damaged heat exchanger must be replaced and the condition that caused the damage resolved before the boiler/water heater is returned to service.
- Replace the heat exchanger and other components in the reverse order of their removal.

## Air Intake & Vent System

Thoroughly inspect the air intake and vent systems for any signs of blockage, corrosion or leakage. Immediately replace any unsound vent system piping. Inspect the air filter and wash with warm water and soap if dirty.

## Controls

Use the "GENERAL OPERATION" and "CHECKING AND ADJUSTMENTS" sections of this manual for reference.

- Check the operating controls for proper operation.
- A float type low water cutoff device must be flushed out per the manufacturers' instructions. The probe on a probe low water cut off must be removed, cleaned and inspected at least once a year. Ensure that the low water cutoffs operate properly. If not, replace them.
- The flow switch contacts must be open when water flow is not present.
- The relief valve should not weep or discharge water at normal system pressure. If it does, contact a qualified service technician to have it inspected. NEVER try to clean or repair the relief valve! If the valve fails to operate properly, have it replaced!
- The aquastat high limit controls the maximum water temperature in the boiler. It is adjustable from **140°F, 60°C to 250°F, 121°C**. If the water temperature reaches the set temperature before the demand for heat has been met, the aquastat high limit should shut the boiler off. The water temperature should never exceed the maximum set point of **250°F, 121°C**. The aquastat high limit cannot be repaired. If it fails to function properly, replace it.
- Visually check the pilot and main burner flames to ensure proper operation, see Figures 16 & 17.

**WARNING: A yellow, floating flame indicates a lack of combustion air. Do not operate the boiler/water heater until the problem is solved or severe personal injury or death may occur!**

Figure 17 – Main Burner Flame

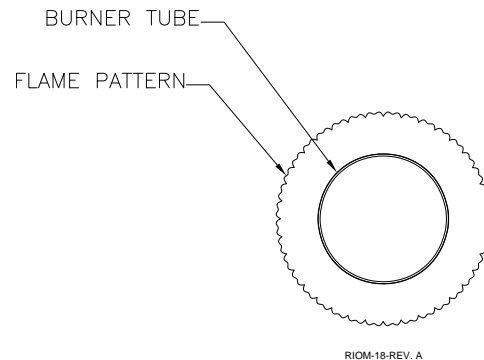

# FUTERA FUSION INSTALLATION AND OPERATION INSTRUCTIONS

## TROUBLE-SHOOTING

<b>PROBLEM</b>	<b>POSSIBLE CAUSES</b>	<b>REMEDIES</b>
No power to control circuit.	Power not connected.	Wire unit to line voltage.
	External circuit breaker open.	Reset breaker.
	Transformer fuse open.	Replace fuse.
No action on call for heat.	Primary limit or other control/interlock open.	<ul style="list-style-type: none"> <li>• Reset limit control or resolve problem as applicable.</li> <li>• If not resolved, check wiring and condition of limit</li> </ul>
	Low water cutoff open.	<ul style="list-style-type: none"> <li>• Check circulating pump.</li> <li>• Check pump contact in control box.</li> <li>• Check LWCO wiring and condition.</li> </ul>
	Operating control sensor(s) not wired or are malfunctioning.	<ul style="list-style-type: none"> <li>• Wire sensor(s) or replace as necessary.</li> <li>• Check error message on control, refer to control documentation.</li> </ul>
	Operating control malfunctioning.	Replace operating control.
No power to pump.	Pump contact not wired.	Wire pump contact in control box.
	Defective pump relay C1.	Replace pump relay C1.
	Operating Control malfunctioning.	Replace operating control
	Pump malfunctioning.	Replace pump.
No power to optional power venter.	Power venter not wired to external power.	Wire power venter as shown in connection diagram.
	Defective power venter timer TD1.	Replace power venter timer TD1.
	Defective flame sense relay.	Replace flame sense relay.
	Power venter fault.	Replace power venter.
Power venter on, no action from unit.	Power venter interlock not wired.	Wire power venter interlock as shown in connection diagram.
No power to blower.	Blower not plugged in.	Plug in blower.
	Defective blower relay C2 (1250-2000 only).	Replace blower relay C2.
	Defective flame sense relay.	Replace flame sense relay.
	Defective variable freq. drive.	Replace variable freq. drive.
	Blower malfunctioning.	Replace blower.
Unit does not spark	Incorrect spark gap or shorted igniter lead.	Properly adjust igniter gap or correct short.
	Bad ground on flame sense module.	Check ground connections, adjust as necessary.
	Low air (blocked flue/inlet) condition.	<ul style="list-style-type: none"> <li>• If conditon exists, check inlet, flue &amp; chimney for blockage.</li> <li>• Check combustion air/ventilation openings in space.</li> <li>• Check inlet air filter, clean and replace as necessary.</li> </ul>
	Spark generator fault.	Check spark generator wiring.
	Defective flame sense relay.	Replace flame sense relay.

# FUTERA FUSION INSTALLATION AND OPERATION INSTRUCTIONS

## TROUBLE-SHOOTING

<b>PROBLEM</b>	<b>POSSIBLE CAUSES</b>	<b>REMEDIES</b>
Unit sparks but pilot will not fire.	Low gas pressure.	Check gas supply pressure during ignition trial, adjust as necessary.
	Pilot valve manual knob closed.	Open pilot valve manual knob.
	Pilot valve wires not connected.	Connect pilot valve wires.
	Low pilot pressure.	Check pilot pressure, adjust as necessary.
	Pilot valve malfunctioning.	Replace pilot valve.
Pilot lights but main burners will not fire.	Defective flame sense relay.	Replace flame sense relay.
	Bad flame sense lead from igniter to spark generator.	Check sense lead & ground connections, rewire as necessary.
	Manual valve(s) closed.	Open manual valve(s).
	Main valve not plugged in.	Plug in main valve.
	Low manifold pressure.	Check manifold pressure during ignition trial, adjust as necessary.
Insufficient heating.	Defective flame sense relay.	Replace flame sense relay.
	Main valve malfunctioning.	Replace main valve.
Unit consistently shuts down on high limit.	Target temperature set too low.	Increasing operating target temperature setting.
	High limit set too low.	Increase high limit setting.
Bad combustion (high CO, yellow flames)	High limit set too low.	Increase high limit setting.
	Insufficient air.	<ul style="list-style-type: none"> <li>• Check CO &amp; CO<sub>2</sub> adjust blower inlet damper(s) to increase airflow.</li> <li>• Check for air box leakage, seal as necessary.</li> </ul>
	Dirty inlet air filter.	Remove inspect and clean inlet air filter as necessary.
Gas flow shuts off during operation (blowers remain on).	Too much air.	Check CO & CO <sub>2</sub> , adjust blower inlet damper(s) to decrease airflow.
	Low air (blocked flue/inlet) condition.	<ul style="list-style-type: none"> <li>• If condition exists, check inlet, flue, chimney for blockage.</li> <li>• Check combustion air/ventilation openings in space.</li> <li>• Check inlet air filter, clean and replace as necessary.</li> <li>• Check pressure switch for correct setting.</li> </ul>

# FUTERA FUSION INSTALLATION AND OPERATION INSTRUCTIONS

Figure 18 – Exploded View

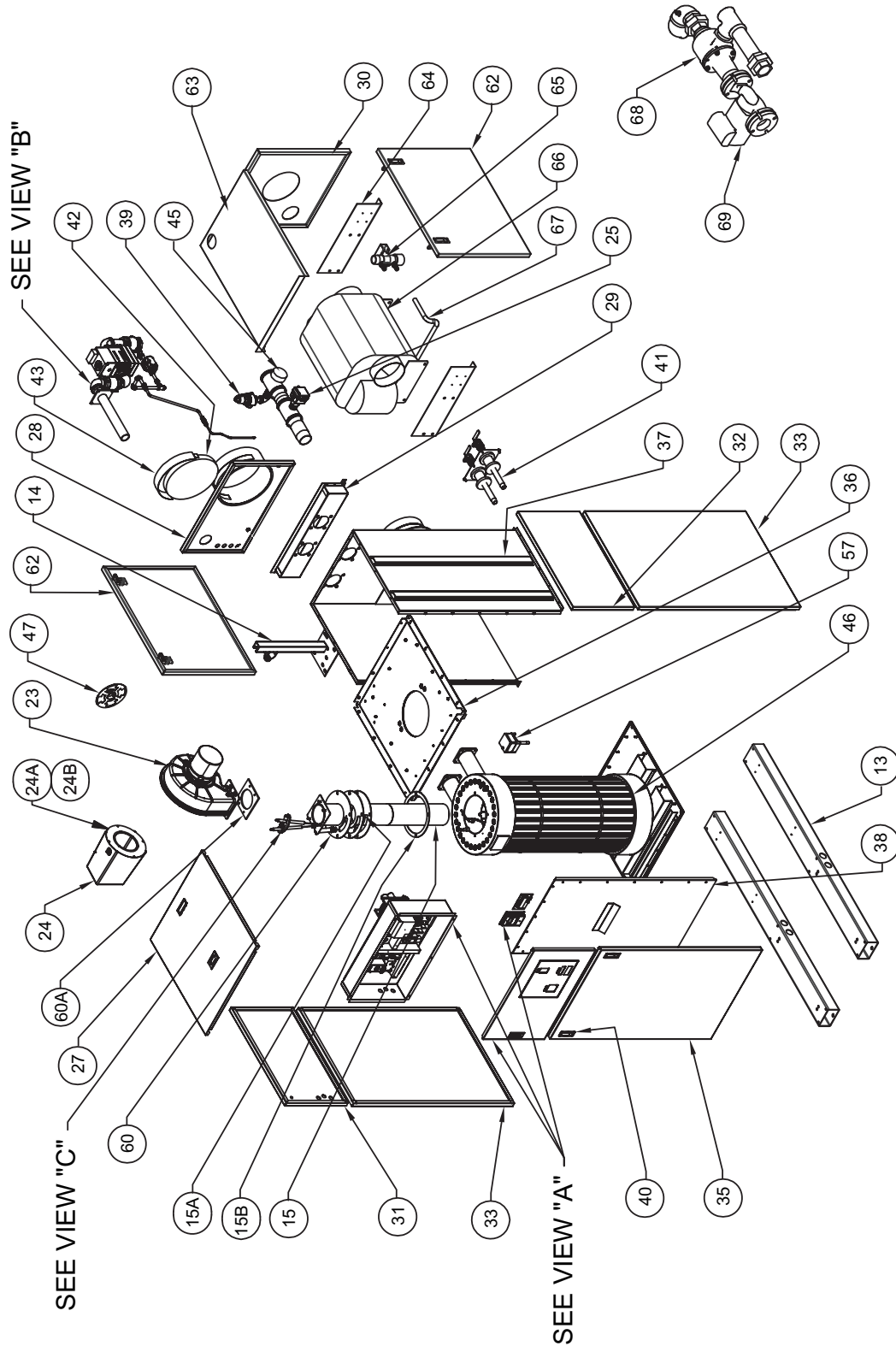

RIOM-20-REV. B

# FUTERA FUSION INSTALLATION AND OPERATION INSTRUCTIONS

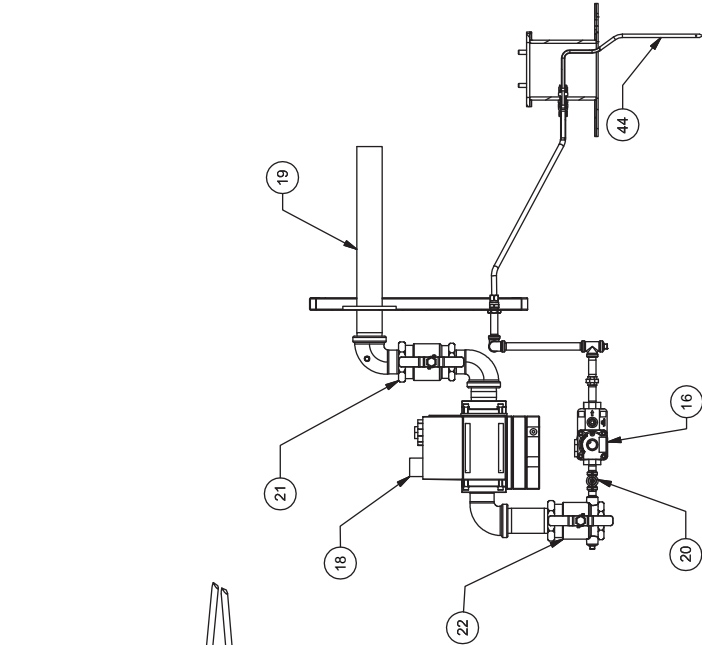

VIEW: B  
ROTATED VIEW

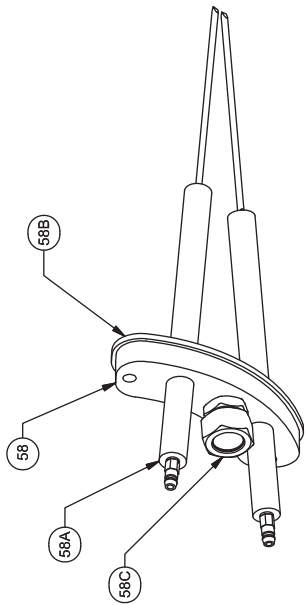

VIEW: C  
R10M-73

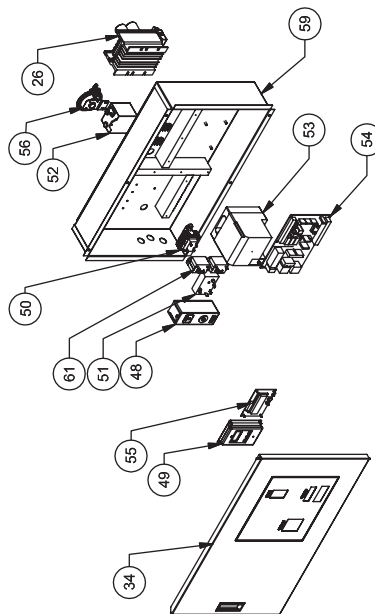
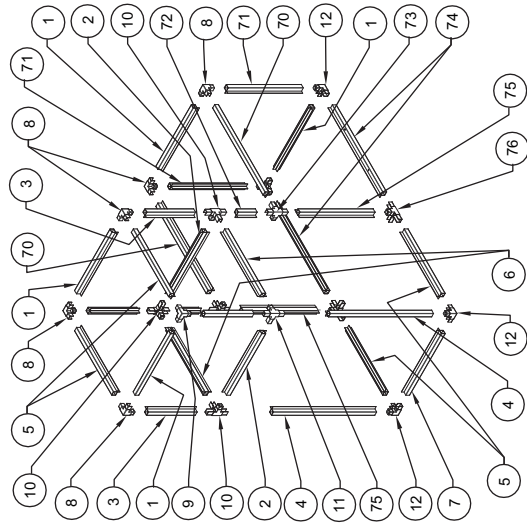

VIEW: A

# FUTERA FUSION INSTALLATION AND OPERATION INSTRUCTIONS

Futera Fusion Model Size with Item Quantities Below									
Ref #	Name of Part	Part #	500	750	1000	1250	1500	1750	2000
1	Top/Bottom X Profile	04-0523	3	3	3				
		04-0524				3	3	3	3
2	Middle X Profile	04-0525	2	2	2				
		04-0526				2	2	2	2
3	Top Y Profile	04-0530	4	4	4	4	4	4	4
4	Bottom Y Profile	04-0531	4						
		04-0532		4					
		04-0533			4				
		04-0534				4			
		04-0535					4		
		04-0536						4	
		04-0537							4
5	Top/Bottom Z Profile	04-0538	4	4	4				
		04-0539				4	4	4	4
6	Middle Z Profile	04-0540	2	2	2				
		04-0541				2	2	2	2
7	Bottom/Front X Profile	04-0524	1	1	1				
		04-0525				1	1	1	1
8	Frame Corner	20-0053	3	3	3	3	3	3	3
9	Frame Corner	04-0543	1	1	1	1	1	1	1
10	Crosses	20-0054	3	3	3	3	3	3	3
11	Drilled Crosses	04-0544	1	1	1	1	1	1	1
12	Bottom Corner	04-0542	4	4	4	4	4	4	4
13	Base Legs	04-1073	2	2	2				
		04-1074				2	2	2	2
14	Gas Train Support Bracket Assembly	70-2344	1	1					
		70-2345			1	1	1		
		70-2346						1	1
15	Burner	10-0280	1						
		10-0309		1					
		10-0308			1				
		10-0286				1			
		10-0288					1		
		10-0290						1	
		10-0292							1
15a	Burner Gasket	06-0026	1	1	1				
		06-0027				1	1	1	1
15b	Burner Gasket	06-0011	1	1	1				
		06-0012				1	1	1	1
16	Solenoid Valve w/Regulator, NG	11-0372	1	1	1	1	1	1	1
	Solenoid Valve w/Regulator, LP	11-0374	1	1	1	1	1	1	1
18	Gas Valve, DMV-SE	11-0211	1	1	1	1	1	1	1
NS	Flange 1"	11-0217	2	2					
NS	Flange 1 1/4"	11-0213			2	2	2		
NS	Flange 1 1/2"	11-0214						2	2
NS	Orifice Gasket	06-0023	1	1					
		06-0022			1	1	1	1	1
19	Main Gas Orifice Assembly	70-2382	1	1	1				
		70-2383				1	1		
		70-2384						1	1
NS	Orifice Plate	03-2911	1						
		03-2912		1					
		03-2913			1				
		03-2914				1			
		03-2915					1		
		03-2916						1	
		03-2917							1
NS	Firing Valve 3/4"	11-0461	1	1	1	1	1	1	1

# FUTERA FUSION INSTALLATION AND OPERATION INSTRUCTIONS

Futera Fusion Model Size with Item Quantities Below									
Ref #	Name of Part	Part #	500	750	1000	1250	1500	1750	2000
20	Ball Valve	11-0395	1	1	1	1	1	1	1
21	Firing Valve, 1"	11-0456	1	1					
	Firing Valve, 1 1/4"	11-0457			1	1	1		
	Firing Valve, 1 1/2"	11-0458						1	1
22	"A" Valve, 1"	11-0465	1	1					
	"A" Valve, 1 1/4"	11-0466			1	1	1		
	"A" Valve, 1 1/2"	11-0467						1	1
23	Blower, Fasco 7043	12-0016	1	1	1				
	Blower, Fasco 7035	12-0017				1	1	1	1
NS	Air Orifice	14-0099	1	1	1	1	1	1	1
24	Mixing Box	20-0051	1	1	1				
		20-0052				1	1	1	1
24a	Airbox Mounting Assembly	70-2309	1	1	1	1	1	1	1
24b	Gasket	06-0045	1	1	1	1	1	1	1
25	Flow Switch	14-0203	1	1	1	1	1	1	1
	Flow Switch (Outdoor)	14-0205	1	1	1	1	1	1	1
NS	2" Outlet Adapter	04-0587	1	1	1				
	2 1/2" Outlet Adapter	04-0588				1	1	1	1
26	Frequency Drive, KBVF-14W	15-0227	1	1	1				
	Frequency Drive, KBVF26D	15-0226				1	1	1	1
27	Jacket Top Panel	70-2412	1	1	1				
		70-2413				1	1	1	1
28	Upper Rear Panel	70-2414	1	1	1				
		70-2415				1	1	1	1
29	Rear Pipe Enclosure Assembly	70-2333	1	1	1				
		70-2334				1	1	1	1
30	Lower Rear Jacket Panel	03-3111	1						
		03-3112		1					
		03-3113			1				
		03-3114				1			
		03-3115					1		
		03-3116						1	
		03-3117							1
31	Upper Left Jacket Panel	03-2831	1	1	1				
		03-2832				1	1	1	1
32	Upper Right Jacket Panel	03-2833	1	1	1				
		03-2834				1	1	1	1
33	Lower Left & Right Jacket Panel	03-2835	2						
		03-2836		2					
		03-2837			2				
		03-2838				2			
		03-2839					2		
		03-2840						2	
		03-2841							2
34	Upper Front Jacket Panel	70-2317	1	1	1				
		70-2318				1	1	1	1
35	Lower Front Jacket Panel	70-2365	1						
		70-2366		1					
		70-2367			1				
		70-2368				1			
		70-2369					1		
		70-2370						1	
		70-2371							1
36	Combustion Chamber Top Panel	70-2356	1	1	1				
		70-2357				1	1	1	1

# FUTERA FUSION INSTALLATION AND OPERATION INSTRUCTIONS

Futera Fusion Model Size with Item Quantities Below									
Ref #	Name of Part	Part #	500	750	1000	1250	1500	1750	2000
37	Combustion Chamber Rear/Side Panel	70-2319	1						
		70-2320		1					
		70-2321			1				
		70-2322				1			
		70-2323					1		
		70-2324						1	
		70-2325							1
38	Combustion Chamber Door Assembly	70-2358	1						
		70-2359		1					
		70-2360			1				
		70-2361				1			
		70-2362					1		
		70-2363						1	
		70-2364							1
39	Pressure Relief Valve 50#	30-0360	1	1	1				
	Pressure Relief Valve 50#	30-0374				1			
	Pressure Relief Valve 50#	30-0379					1	1	1
	Pressure Relief Valve 125#	30-0364	1	1	1	1	1	1	1
40	Latch	20-0046	2	2	2	2	2	2	2
41	Drain Valve Assembly (CB)	70-2427	1	1	1				
		70-2428				1	1	1	1
	Drain Valve Assembly (CW)	70-2429	1	1	1				
		70-2430				1	1	1	1
42	Air Filter	09-0489	1	1	1				
		09-0498				1	1		
		09-0499						1	1
43	Filter Cover	03-2206	1	1					
		03-2207			1	1	1		
		03-2208						1	1
44	Pilot Assembly	70-9024	1	1	1				
		70-9025				1	1	1	1
45	Tridicator (CB) 30-50 psi	13-0308	1	1	1	1	1	1	1
	Tridicator (CB) 60 - 160 psi	13-0305	1	1	1	1	1	1	1
46	Heat Exchanger (Copper)	70-2186	1						
		70-2187		1					
		70-2188			1				
		70-2189				1			
		70-2190					1		
		70-2191						1	
		70-2192							1
	Heat Exchanger (Cupronickel)	70-2193	1						
		70-2194		1					
		70-2195			1				
		70-2196				1			
		70-2197					1		
		70-2198						1	
		70-2199							1
47	Air Damper Assembly	70-2351	1	1	1				
		70-2353				1	1		
		70-2354						1	1
48	High Limit, L4008E, (CB)	14-0112	1	1	1	1	1	1	1
	High Limit, L4008E, (CW)	14-0105	1	1	1	1	1	1	1
NS	Operator, T6031A (pool heater) (Canada Only)	14-0003	1	1	1	1	1	1	1
NS	Thermometer Well, 3/8 x 2	13-0102	2	2	2	2	2	2	2
NS	High Limit Well, 3/8 x 3	13-0104	2	2	2	2	2	2	2
49	Tekmar MPA Control	14-0322	1	1	1	1	1	1	1
	Tekmar MPA Control (Outdoor Reset Only)	14-0324	1	1	1	1	1	1	1
NS	Tekmar 071 Temperature Sensor	14-0308	3	3	3	3	3	3	3
	Outdoor Sensor & Enclosure	14-0319	1	1	1	1	1	1	1
50	Transformer, 40 VA	15-0002	1	1	1	1	1	1	1

# FUTERA FUSION INSTALLATION AND OPERATION INSTRUCTIONS

Futera Fusion Model Size with Item Quantities Below									
Ref #	Name of Part	Part #	500	750	1000	1250	1500	1750	2000
NS	Pump Contactor (C1, C2)	15-0118	1	1	1	1	1	1	1
51	Purge Timer, ST7800	16-0007	1	1	1	1	1	1	1
52	Spark Generator, Q652B	16-0008	1	1	1	1	1	1	1
53	Flame Safeguard, RM7897C	16-0024	1	1	1	1	1	1	1
54	Main Board	40-0068	1	1	1	1	1	1	1
55	Display Board	40-0069	1	1	1	1	1	1	1
NS	Ribbon Cable	40-0115	1	1	1	1	1	1	1
NS	Toggle Switch	48-0010	1	1	1	1	1	1	1
56	Air Pressure Switch	11-0416	1	1	1	1	1	1	1
57	Blocked Flue Switch	11-0411	1	1	1	1	1	1	1
NS	Terminal Block 6P	48-0157	1	1	1	1	1	1	1
NS	Terminal Block 4P	48-0161	1	1	1	1	1	1	1
NS	Resistor Assembly	70-9001	1	1	1	1	1	1	1
NS	Mini Peeper, C7027A	16-0009	1	1	1	1	1	1	1
NS	UV Amplifier, R7849A	16-0006	1	1	1	1	1	1	1
NS	Base, Q7800A	16-0003	1	1	1	1	1	1	1
NS	Ignition Cable	44-0056	1	1	1	1	1	1	1
58	Pilot/Flame Rod Kit	70-2303	1	1	1				
		70-2304				1	1	1	1
58a	Electrode	16-0333	2	2	2	2	2	2	2
5b	Electrode Gasket	06-0024	1	1	1				
		06-0025				1	1	1	1
58c	View Port Assembly	70-2205	1	1	1	1	1	1	1
59	Control Box Panel	70-2376	1	1	1				
		70-2377				1	1	1	1
NS	Harness RM7800	40-0117	1	1	1	1	1	1	1
NS	Harness 120V Switch	40-0118	1	1	1	1	1	1	1
NS	Harness Tekmar	40-0119	1	1	1	1	1	1	1
NS	Harness Transformer	40-0120	1	1	1	1	1	1	1
NS	Harness VFD	40-0121	1	1	1	1	1	1	1
60	Transition Assembly	70-2305	1	1	1				
		70-2306				1	1	1	1
60a	Gasket	06-0043	1	1	1				
		06-0044				1	1	1	1
61	Pump Contactor Relay	15-0118	1	1	1	2	2	2	2
62	Left & Right Side Jacket Panel Extension	03-3101	2						
		03-3102		2					
		03-3103				2			
		03-3104					2		
		03-3105						2	
		03-3106							2
		03-3107							
63	Jacket Top Panel Extension	03-3108	1	1	1				
		03-3109				1	1		
		03-3110						1	1
64	Economizer Mounting Bracket	03-3118	1	1					
		03-3119			1				
		03-3120				1	1	1	1
65	Condensate Drain Assembly	70-4001	1	1	1	1	1	1	
66	Economizer	12-2001	1	1	1				
		12-2002				1	1		
		12-2003						1	1
67	Condensate Hose (ft)	62-0301	3	3	3	3	3	3	
68	Thermostatic Valve (CB) 2" Cast Iron	13-0201	1	1	1				
	Thermostatic Valve (CB) 2 1/2" Cast Iron	13-0202				1	1	1	1
	Thermostatic Valve (CW) 2" Bronze	13-0203	1	1	1				
	Thermostatic Valve (CW) 2 1/2" Bronze	13-0204				1	1	1	1
69	Pump	(see pump selection chart in Trade Price Book)							
70	Top Horizontal Frame Extension Profile	04-1069	2	2	2				
		04-1071				2	2	2	2

# FUTERA FUSION INSTALLATION AND OPERATION INSTRUCTIONS

Futera Fusion Model Size with Item Quantities Below									
Ref #	Name of Part	Part #	500	750	1000	1250	1500	1750	2000
71	Vertical Frame Extension Profile	04-1055	2						
		04-1056		2					
		04-1057			2				
		04-1058				2			
		04-1059					2		
		04-1060						2	
		04-1061							2
72	Vertical Center Frame Extension Profile	04-1052	2	2	2				
		04-1053				2	2		
		04-1054						2	2
73	Frame Cross 4 Way Rear	04-1021	2	2	2	2	2	2	2
74	Bottom Horizontal Frame Extension Profile	04-1072	2	2	2				
		04-1070				2	2	2	2
75	Vertical Center Extension Profile	04-1062	2						
		04-1063		2					
		04-1064			2				
		04-1065				2			
		04-1066					2		
		04-1067						2	
		04-1068							2
76	Frame Cross 4 Way Bottom	04-1020	2	2	2	2	2	2	2
NS	Stainless Steel Wipes	66-0050	1	1	1	1	1	1	1
NS	Rating Plate	82-0054	1	1	1	1	1	1	1
NS	Futera Fusion Overlay	82-0195	1	1	1	1	1	1	1
NS	Paint	66-0013	1	1	1	1	1	1	1
NS	Silicone	66-0151	1	1	1	1	1	1	1
<b>OPTIONS</b>									
NS	Alarm Bell	70-2232	1	1	1	1	1	1	1
NS	Main Flame Status Contact	30-0759	1	1	1	1	1	1	1
NS	Low Gas Pressure Switch (Manual Reset)	11-0410	1	1	1	1	1	1	1
NS	High Gas Pressure Switch (Manual Reset)	11-0411	1	1	1	1	1	1	1
NS	Flow Switch (Potter)	14-0201	1	1	1	1	1	1	1
NS	C.A.D. Dry Contact	30-0782	1	1	1	1	1	1	1
NS	Freeze Protection Kit, 8" Damper	70-2330	1	1	1				
	Freeze Protection Kit, 12" Damper	70-2332				1	1	1	1
NS	Pump Contactor 3PH	15-0111	1	1	1	1	1	1	1
NS	Keyboard Display Module, S7800A	16-0010	1	1	1	1	1	1	1
NS	Vent Termination Hood 5"	09-0117	1	1					
	Vent Termination Hood 6"	09-0112			1	1			
	Vent Termination Hood 8"	09-0113					1		
	Vent Termination Hood 10"	09-0115						1	1
NS	Air Intake Hood 6"	09-0102	1	1	1				
	Air Intake Hood 8"	09-0103				1			
	Air Intake Hood 10"	09-0104					1		
	Air Intake Hood 12"	09-0105						1	1

# FUTERA III / FUSION STARTUP SHEET



DATE:	JOB NAME:
TECHNICIAN:	LOCATION:
COMPANY:	MODEL
PHONE NUMBER:	SERIAL #:

## PRE-STARTUP CHECK LIST

- |  |  |
|--|--|
| <input type="checkbox"/> NO VISUAL DAMAGE TO UNIT  | <input type="checkbox"/> INLET AIR FILTER INSTALLED AND CLEAN              |
| <input type="checkbox"/> PIPING PROPERLY CONNECTED | <input type="checkbox"/> PROPER SERVICE CLEARANCE PROVIDED                 |
| <input type="checkbox"/> BOILER CIRCULATOR WIRED   | <input type="checkbox"/> PUMP RUNNING, HEAT EXCHANGER FULL                 |
| <input type="checkbox"/> VENT/STACK CONNECTED      | <input type="checkbox"/> GAS LINES PURGED, NO LEAKS, NO MISSING TEST PLUGS |

## BOILER STARTUP SEQUENCE

**Note:** Locate the AA terminals in the bottom-right of the electrical panel on the control relay board and the min-hold switch located on the display board. Also locate the gas pressure tapping upstream of the main gas valve.

1. Cycle boiler and hold at trial for pilot ignition.
2. Set pressure to 2 - 2.5" W.C. (Flame signal should read 5.0 V DC)
3. Cycle boiler to main flame trial for ignition.
4. Place boiler to min hold (33%).
5. Record combustion and elbow pressure. (Reference factory start-up sticker)
6. Release boiler from min hold to run. (Jumper AA terminals for 100% input)
7. Record combustion and elbow pressure. (Reference factory start-up sticker)
8. Check all combustion results using a calibrated flue gas analyzer.
9. Remove jumper at terminals AA and release boiler to RUN mode.

COMBUSTION ANALYSIS	33% FIRE	100% FIRE
GAS PRESSURE (IN. W.C.)		
CO <sub>2</sub>		
O <sub>2</sub>		
CO (PPM)		
NET STACK TEMP.		

## TESTING MODULATING BOILER CONTROL

Allow the boiler to control itself through the Modulating Boiler Control. Check sticker on the inside of the door or the Installation Manual for instructions on using the boiler control.

BOIL TARGET		TANK DIFF (MODE 3)		PUMP DELAY	
BOILER OUT		BOIL MAX		UNITS	
BOILER IN		BOIL MIN		SECONDARY INLET TEMP (FUTERA FUSION ONLY)	
MODE		BOIL MASS		SECONDARY OUTLET TEMP (FUTERA FUSION ONLY)	
TANK TARGET (MODE 3)		BOILER DIFF			

## SAFETY TESTS CHECKLIST

- FLOW SWITCH                       AIR SWITCH                       FLAME SAFEGUARD  
 LOW WATER CUTOFF               HIGH-LIMIT

## COMMISSIONING THE BOILER/WATER HEATER

<input type="checkbox"/> UNIT CYCLED MIN. OF 15 TIMES <input type="checkbox"/> CUSTOMER INSTRUCTED <input type="checkbox"/> ALL COVERS REPLACED <input type="checkbox"/> CUSTOMER GIVEN MANUAL <input type="checkbox"/> TARGET TEMP. SET PER CUSTOMER  COMMISSIONED BY: _____ <div style="text-align: right;">(SIGNATURE)</div> DATE: _____	<p>THE DELTA T BETWEEN THE HEATERS INLET AND OUTLET IS CRITICAL TO PROPER FLOW. BEFORE YOU LEAVE THE JOBSITE, YOU MUST RECORD THE DELTA T. THIS READING SHOULD NOT EXCEED 35 DEG F, 19.4 DEG C, OR BE LOWER THAN 20 DEG F, 11.1 DEG C.</p> <p style="text-align: center;"> <input style="width: 60px; height: 20px;" type="text"/> DELTA T       </p>
---	---

## ADDITIONAL NOTES AND COMMENTS

---



---



---



---



---



---



---



260 North Elm Street  
Westfield, MA 01085  
Phone: (413) 568-9571  
Fax: (413) 568-9613

7555 Tranmere Drive  
■ Mississauga, Ontario L5S 1L4 Canada  
Phone: (905) 670-5888  
Fax: (905) 670-5782

[www.rbiwaterheaters.com](http://www.rbiwaterheaters.com)

