

INSTALLATION, OPERATING & MAINTENANCE MANUAL WING STEADYAIR® UNITS

INTRODUCTION

You have purchased the finest in industrial heating equipment. Read these instructions to be assured of optimum performance.

I. RECEIVING, HANDLING, AND PRE-INSTALLATION CHECKS OF WING STEADYAIR® UNITS

1. Depending on unit size and accessories included, the shipment may be made in two or more sections. Check items received against packing list and bill of lading.
2. All parts should be carefully inspected to determine if any damage has incurred in shipment; especially fan wheel, shaft, bearings and externally supported components.
3. *ANY SHORTAGES AND/OR CLAIMS FOR DAMAGE SHOULD BE IMMEDIATELY REPORTED TO THE DELIVERING CARRIER FOLLOWED BY FILING A CLAIM FOR SHORTAGES AND/OR DAMAGES.*
4. Special care should be taken when handling and assembling component sections of the unit. Rough handling can result in bearing damage, bent blower shaft, etc.

Angle iron or heavy gauge steel angles with holes are provided on the top of components for unit lifting. *THE UNIT SHOULD NOT BE LIFTED BY ONLY ONE COMPONENT.* Spreader bars are to be used to separate the lifting slings.

CAUTION: Never hoist the unit by attaching hooks to the top flanges or header of the face and bypass coils.

Do not remove protective caps from coil headers until ready to connect piping. Do not remove protective grease from fan shaft. Plywood or heavy cardboard should be placed as walkways in fan section to prevent damage to insulation when supplied. This plywood or cardboard *MUST* be removed once installation is complete.

5. If unit is to be stored for more than 2 weeks prior to installation, the following precautions should be observed:

Select a storage site that is reasonably level and sturdy to prevent undue stress or permanent damage to the unit structure and/or components. Do not store unit on vibrating surface. Damage to stationary bearings may result.

Cover entire unit with a tarp. Extend cover under unit if stored out of doors and adequately secure cover. *DO NOT LET THE STEADYAIR UNIT SET ON GROUND. SUPPORT ABOVE MUD AND WATER LEVEL.*

MONTHLY: REMOVE TARP, AND ROTATE FAN AND MOTOR SLOWLY BY HAND TO REDISTRIBUTE BEARING GREASE AND TO PREVENT BEARING CORROSION.

For cold storage (below -20°F) some units are available with built-in component heaters which should be wired to have power to the heaters to protect motor gears, internal friction points and controls. Check job specifications to see if these were supplied.

II. INSTALLATION

1. The unit must be installed level to prevent distortion, insure proper damper operation, and coil drainage.
2. Adequate space around unit should be provided for maintenance. Service clearances for access panels and doors, fan shaft and coil removal, filter removal for cleaning and replacement, lubrication access, damper linkage access, and motor and belt adjustment should be considered.
3. Dimensional drawings illustrate component assembly. When shipped separately, screws, gasketing (when required), nuts and bolts are included for this purpose.
4. Flexible ducting should be used between the unit and both supply and return air ducts.
5. When unit is located on or hung from roof, it must be mounted on support beams that span load bearing columns. If not done, excessive vibration may occur due to the resiliency of the roof.
6. Fan noise is a function of CFM, static pressure, efficiency, and design of the fan. Fan noise measuring methods do not evaluate the pure tones generated by some fans and, when radiated into occupied spaces, these tones can be objectionable. On critical applications, it is recommended that sound attenuation be provided in the octave band containing the tone.
7. Internally isolated fan boxes have isolators installed and adjusted at the factory. Blower assembly tie down bolts should be removed before start-up.
8. Motors and drives are installed at the factory when unit is tested. However, shipment may cause sheave alignment and belt tension to change. Therefore, the following must be performed before start-up:

Check angular and parallel alignment of sheaves.

Tighten all sheave and bearing set screws (use torque wrench and tighten to specified torque as outlined in the table below:

TORQUE FOR TIGHTENING SETSCREWS			
Set-Screw Dia.	Hex Size Across Flat	Min. Recommended Torque	
		inch lbs.	foot lbs.
1/4	1/8	85	7.2
5/16	5/32	164	13.7
3/8	3/16	296	24.7
7/16	7/32	452	37.7
1/2	1/4	655	54.6
5/8	5/16	1435	119.6

Loosen motor base locknut(s) and adjust belt tension by turning adjusting screws. With correct belt tension, belts may squeal initially on start-up and will quiet down when blower reaches operating speed. Excessive belt tension reduces belt life, and may cause bearing and shaft damage.

Secure locknut(s) and check all bolts on motor base for tightness.

III. PIPING INSTRUCTIONS

1. IFB Coil (see IFB IOM Manual)
2. VIFB Coil (see VIFB IOM Manual)
3. Cooling Coils.
 - a. Chilled Water Coils — Complete drainage and flushing with antifreeze of water coils is recommended during winter months. All water coils are supplied with a vent and drain connection (1/4" MPT). Coils must be adequately vented in order to prevent air binding.
 - b. Direct Expansion — Coils supplied have single or double distributors. Double distributor coils are either face or row split depending on job specification.
 - c. The expansion valve utilized must be of the external equalizer tube type. The expansion valve bulb must be located on the suction line at the coil, in accordance with instructions with expansion valve.
 - d. All refrigerant piping practices should be in accordance with local codes and the latest ANSI Standard B9 safety code. Hard drawn type "L" or "K" copper tubing should be used. Good practices should be followed as to pulling adequate vacuum, tubes cleaned of foreign material, etc.
 - e. Condensate Drain Trap

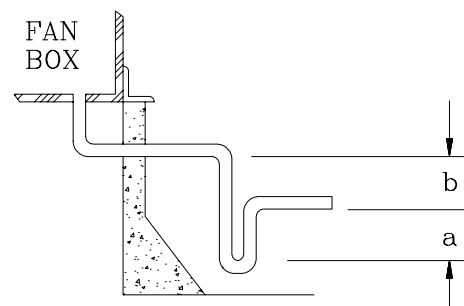

- a) Equal to or greater than the fan section negative at design operating conditions.
- b) Equal to (a) for water storage to prevent losing seal.

CEILING SUSPENDED

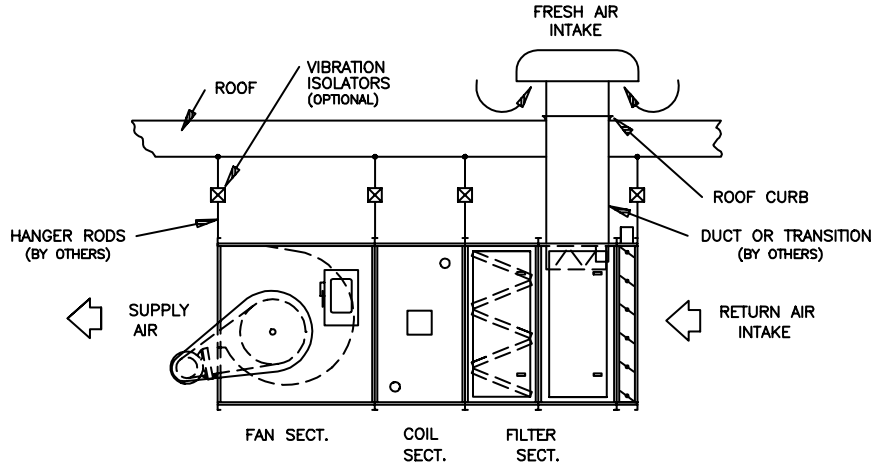

BASE SUPPORTED

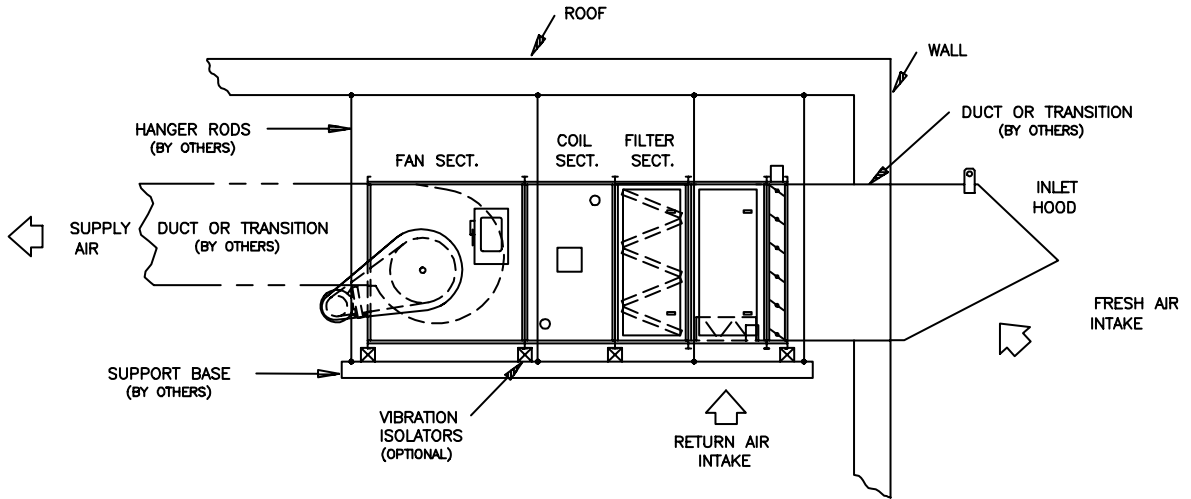

ROOF MOUNTED

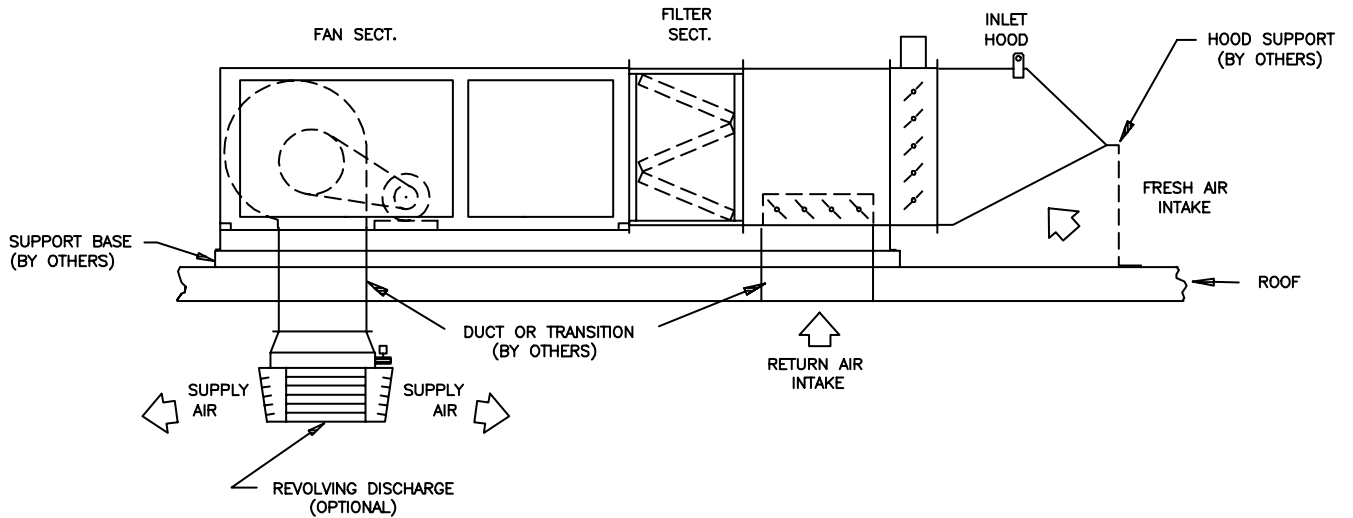

IV. START-UP

1. General
 - a. Make sure all bolts and screws are tight.
 - b. Review items listed under Section II.
 - c. Check for proper blower rotation.
 - d. Check the amperage draw of the motor. It should not exceed the nameplate amps shown on the motor serial plate.
2. Control Checklist for IFB or VIFB coil (see IFB IOM Manual or VIFB IOM Manual.)

V. MAINTENANCE

1. After approximately 2 weeks of operation, the drive belts will have nearly acquired their permanent stretch. At this time the belt tension should be checked and adjusted. After this, belt tension should be checked every three months.
2. The fan shaft bearings are self-aligning, pillow block, ball bearing type with screw-in grease zerks for relubrication. Internal bearings may have optional extended lube lines with fittings mounted on the exterior of the fan box.

3. Bearings should be lubricated accordingly to table below with a lithium based grease conforming to #2 consistency. *SPECIAL GREASE MAY HAVE BEEN SUPPLIED FOR OPERATION OR STORAGE OUTSIDE THE -10 °F TO 200 °F STD. BEARING RATING. CHECK UNIT SPECIFICATIONS BEFORE GREASING BEARINGS.*
4. The unit filters should be periodically inspected and cleaned or replaced when necessary. Do Not operate the system without filters.
5. The Wing face and bypass heating coils should be periodically inspected for continuous satisfactory operation. Loose nuts, bolts and screws should be tightened. Crank arm pivots and damper rods should be checked for wear and replaced if worn.
6. Steam traps should be checked for proper operation. Strainers, dirt pockets and drip legs should be cleaned periodically. Air valve on hot water installations should be checked for proper operation.

LUBRICATION INSTRUCTIONS			
Speed	Temperature	Cleanliness	Greasing Intervals
100 RPM	Up to 120°F	Clean	6 to 12 Months
500 RPM	Up to 150°F	Clean	2 to 6 Months
1000 RPM	Up to 210°F	Clean	2 Weeks to 2 Months
1500 RPM	Over 210°F - 250°F	Clean	Weekly
1500 - 200 RPM	Up to 150°F	Dirty	1 Week to 1 Month
	Over 150°F - 250°F	Dirty	Daily to 2 Weeks
	Any Temp. - 250°F	Very Dirty	Daily to 2 Weeks
	Any Temp. - 250°F	Extreme Conditions	Daily to 2 Weeks



4830 TRANSPORT DRIVE, DALLAS TX 75247
TEL.: (214) 638-6010 FAX: (214) 905-0806
<http://www.mestek.com>