



APPLYING THE L.J. WING FRESH AIR SUPPLY (FAS) UNIT FOR BOILER ROOM COMBUSTION AIR PREHEAT





4830 Transport Drive, Dallas, TX 75247 Tel. (214) 638-6010 Fax (214) 905-0806
www.ljwing.com

In the interest of product improvement, L.J. Wing reserves the right to make changes without notice.

TABLE OF CONTENTS

<i>Why Combustion Air is Needed</i>	4
<i>Integral Face and Bypass Coil Operation</i>	5
<i>Design and Construction</i>	6
<i>Model Number Description</i>	7
<i>Performance</i>	8
<i>Selection</i>	9
<i>Dimensions</i>	10
<i>Piping</i>	11
<i>Controls</i>	12-15
<i>Typical Specification and Schedule</i>	16

WHY COMBUSTION AIR IS NEEDED

How the L.J. Wing Fresh Air Supply System Helps

Boilers need combustion air! The latest International Building Code prescribes 1 cubic foot per minute of combustion air for every 2,400 Btu per hour of boiler output heat. This is approximately equivalent to 17.4 cubic feet per minute for every boiler HP. Introducing this outside air into the boiler room in winter, however, presents a significant engineering design challenge. If the air is left unheated, the boiler room could become uncomfortably chilly, possibly even presenting a threat of freezing. L.J. Wing's Fresh Air Supply Unit (or FAS) eliminates both of these potential problems.

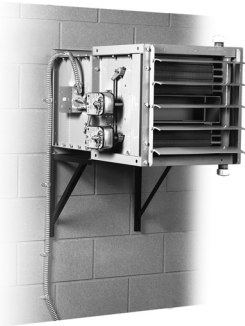

Designed for installation in wall openings, the horizontal airflow FAS-U heater draws in air through weatherproof hoods or wall louvers, passes the air over a uniquely designed integral face and bypass heating coil, and discharges the air through adjustable vanes to achieve the desired airflow pattern. The temperature of the heated air is held constant by continually repositioning the coil's face and bypass dampers as the outdoor air temperature changes. Freeze potential is minimized as the coil is continually maintained at full steam pressure or full water/glycol flow.



Reduces Louver Sizes

Air brought directly into a boiler room through a louvered opening must be sized by code for a

minimum of approximately 0.1 square feet per boiler HP. This can lead to some large wall space demands. For example, a boiler room with a boiler load of 400 HP would require a minimum louvered opening of nearly 40 square feet. The FAS-U heater reduces the opening size by 65-75%, thereby resulting in substantial louver and wall space savings as well as a more architecturally pleasing appearance.

Increases Boiler Efficiency

Preheating the boiler combustion air also increases boiler efficiency. According to the Dept. of Energy, a boiler gains one percentage point of efficiency for every 40 degree F rise in combustion air temperature. So, preheating outside air from -10 degrees F to 70 degrees F (an 80 degree F rise) results in a 2% boiler efficiency improvement. Over time, this can lead to substantial savings in operating costs.

Improves Reliability

Maximum coil freeze protection improves the reliability of boiler room operation.

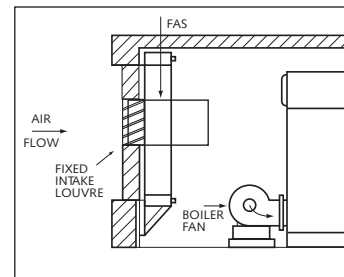

Simplifies Installation

Installation is greatly simplified with the FAS-U heater. The unit can ship complete with controls, and because the bypass section is integral to the coil, installation of a separate bypass section is not required. Piping and electrical connections are all that are necessary.

Design flexibility

Should design constraints preclude the use of a horizontal airflow FAS-U heater, a vertical airflow FAS heater, designated FAS-HC, may be used. Selection and performance is identical to that of the horizontal airflow unit. Consult L.J. Wing Technical Guide TGFAS for more information on FAS-HC heaters.

OPERATION

Integral Face and Bypass Coil Operation

C000606

The integral face and bypass coil design incorporated into the FAS heater consists of a number of alternate heating passages (A) and by-pass passages (B). Full steam or water flow is maintained in the heated, or “face”, section at all times, while air flowing through the bypass passages is not heated. The integral face and bypass design allows discharge air to blend into a single stream of uniform temperature to satisfy design requirements. Each passage is provided with a volume control damper.

Two synchronized electric or pneumatic, spring-return damper motors are provided, one to operate the face set of dampers and one to operate the bypass set of dampers. The damper motors are actuated by either an airstream or room thermostat as required.

When no fresh air supply is needed, such as during non-operating hours, the fan motor will be off. If the unit is equipped with electric damper motors, both sets of dampers will be closed to prevent infiltration of cold outside air into the boiler room. If the unit is equipped with pneumatic damper motors, the face dampers will be open and the bypass dampers will be closed.

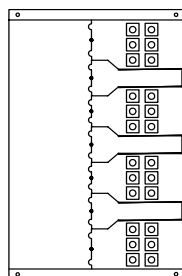
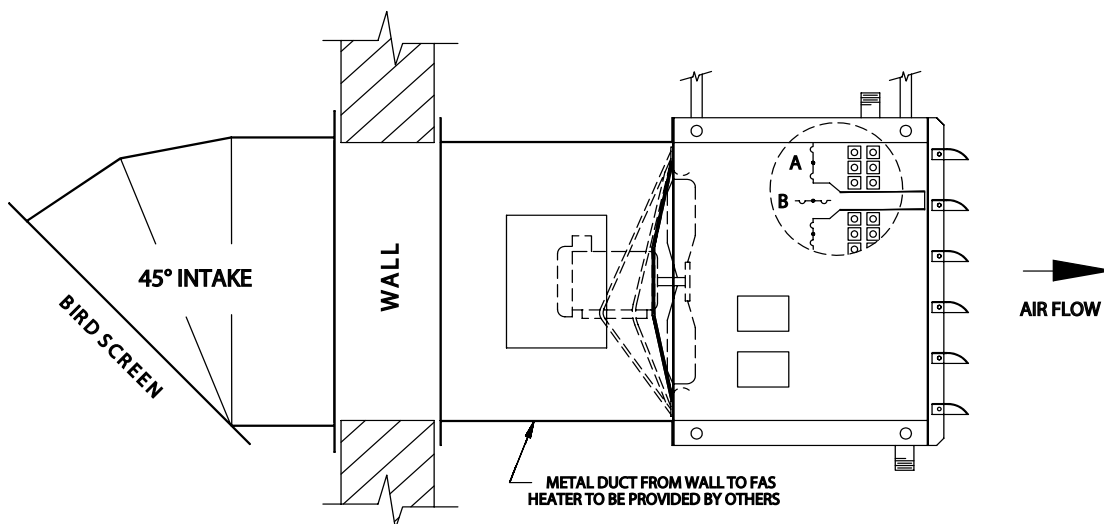

FIGURE 1

WHEN THE UNIT'S FAN IS NOT RUNNING, ALL THE DAMPERS REMAIN CLOSED TO PREVENT INFILTRATION OF OUTSIDE AIR.

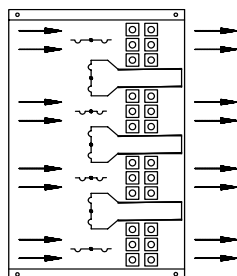

FIGURE 2

WHEN MAXIMUM HEAT IS REQUIRED, THE BYPASS DAMPERS ARE COMPLETELY CLOSED AND ALL OUTSIDE AIR IS DIRECTED THROUGH THE HEATING CHANNELS.

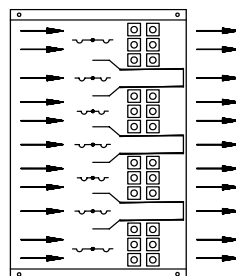

FIGURE 3

AS THE OUTSIDE AIR TEMPERATURE RISES NEAR THE THERMOSTAT SETTING, FRESH AIR PASSES THROUGH BOTH THE HEATING AND BYPASS CHANNELS.

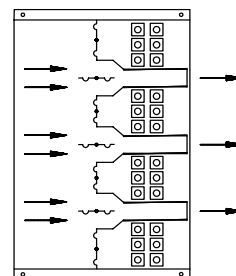

FIGURE 4

WHEN THE OUTSIDE AIR TEMPERATURE EXCEEDS THE THERMOSTAT SETTING, THE AIR IS DELIVERED THROUGH THE BYPASS CHANNELS ONLY.

DESIGN AND CONSTRUCTION

Construction Details

Heating element

Type: Fin and tube, extended surface type.
Tubes: 3/8" O.D. copper, 0.028" thick wall
Fins: Smooth, rectangular aluminum fins, 0.010" thick; mechanically bonded to the tubes.
Headers: Schedule 40 steel, connected to tubes by a brazed joint.

Casing assembly

Material: 14 gauge galvanized steel.
Attachment to heating elements: By heavy key plates welded to the headers. Tube ends are guided, spaced and secured against vibration by channel-shaped retainers.
Finish: Air-dried, alkyd enamel paint.

Face and bypass dampers:

Material: 16 gauge galvanized steel The heater coil banks and by-pass passages are alternated for proper air proportioning.

Fan:

Type: Propeller
Material: Aluminum through size 27; steel for larger sizes.

Motor:

Type: Totally enclosed, fan-cooled (TEFC)
Frame: 'C' face frame through size 27; rigid base for larger sizes.

Motor and Sound Table

FAS SIZE	FACE AREA (SQ.FT.)	MOTOR HP		FAN RPM	SOUND POWER LEVEL - dB	SOUND PRESSURE LEVEL IN Dba AT DISTANCE FROM UNIT			
		SINGLE PHASE	THREE PHASE			5 FT.	10 FT.	15 FT.	20 FT.
13	1.15	1/6	1/4	1,150	78.0	55.7	49.7	46.2	43.7
17	1.71	1/6	1/4	1,150	79.0	55.9	49.9	46.4	43.9
19	2.43	1/4	1/4	1,150	82.0	59.1	53.1	49.6	47.1
22	3.67	1/4	1/4	1,150	84.4	61.2	55.2	51.7	49.2
24	3.67	1/2	1/2	1,150	86.0	63.6	57.6	54.1	51.6
25	5.44	1/2	1/2	1,150	96.3	76.8	70.8	67.3	64.8
27	5.44	3/4	3/4	1,150	98.0	78.4	72.4	68.9	66.4
30	7.63	3/4	3/4	850	92.5	75.1	69.0	65.6	63.1
33	9.10	1-1/2	1-1/2	850	94.5	76.6	70.6	67.1	64.6
36	10.90	1-1/2	1-1/2	850	95.0	77.1	71.1	67.6	65.1
38	10.90	2	2	850	97.0	79.0	73.0	69.5	67.5
40	16.00	3	3	850	99.0	80.2	74.2	70.7	68.2
41	16.00	3	3	850	99.5	80.7	74.7	71.2	68.7
43	23.00	5	5	850	101.5	83.5	77.5	74.0	71.5
44	23.00	7-1/2	7-1/2	850	102.8	84.9	78.9	75.4	72.9

Note:

1. Single-phase units through size 27 and all three-phase, 230 or 460 volt, units are available with direct-drive motors. Single-phase and three-phase units size 30 and larger are also available in belt-drive motor configurations.

MODEL NUMBER DESCRIPTION

Model Number Description

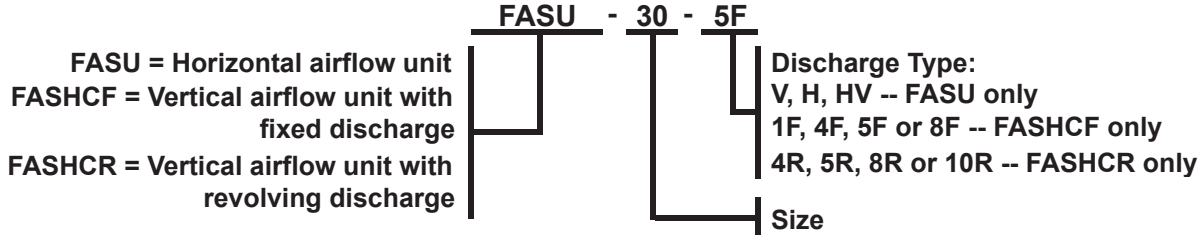

Note: Only FAS type FASU is described in this manual. For information on vertical units (Types FASHCF and FASHCR) please consult Technical Guide TGFAS.

PERFORMANCE

Steam and Water Units

TABLE 1

FAS	BASE PERFORMANCE WITHOUT FILTERS				
	CFM	MAX MBH	MAX HP	BATRS	BATRW
13	855	1,640	49	96.3	71.7
17	1,400	2,685	80	92.4	67.8
19	2,000	3,836	115	92.2	67.6
22	2,750	5,274	158	96.0	71.4
24	3,700	7,096	212	84.3	60.1
25	4,300	8,246	247	93.8	69.2
27	5,300	10,164	304	85.6	61.3
30	7,000	13,424	401	87.9	63.4
33	8,500	16,301	487	87.2	62.8
36	10,000	19,178	573	87.9	63.4
38	13,000	24,931	745	77.7	55.2
40	16,000	30,684	917	84.6	60.4
41	17,200	32,985	986	81.8	58.1
43	22,000	42,191	1,261	86.3	61.9
44	26,000	49,862	1,491	79.9	56.6

Notes:

- (1) MAX MBH and MAX HP = Maximum boiler output for which unit can be applied.
- (2) BATRS = Base air temperature rise for steam units at 15 psig pressure.
- (3) BATRW = Base air temperature rise for water units at 200 degrees F entering water temperature.

TABLE 2

FAS	BASE PERFORMANCE WITH FILTERS				
	CFM	MAX MBH	MAX HP	BATRS	BATRW
13	600	1,151	34	111.8	87.0
17	800	1,534	46	116.6	91.6
19	1,400	2,685	80	107.4	82.7
22	2,000	3,836	115	109.8	85.1
24	3,000	5,753	172	92.4	67.8
25	3,500	6,712	201	102.5	77.9
27	4,500	8,630	258	92.0	67.4
30	6,600	12,657	378	90.2	65.6
33	8,200	15,726	470	88.6	64.1
36	9,500	18,219	545	89.9	65.3
38	12,400	23,780	711	79.6	56.4
40	15,300	29,342	877	86.3	61.9
41	16,400	31,451	940	83.6	59.6
43	20,500	39,314	1,175	89.0	64.5
44	25,000	47,944	1,433	81.4	57.7

TABLE 3

STEAM PRESSURE (PSIG)	SATURATED TEMP., SST (DEGREES F)	LATENT HEAT (BTU)
5	227.1	960.4
10	239.0	952.6
15	249.5	945.7

TABLE 4

FAS SIZE	BASE WATER FLOW RATE, GPMB (GPM)	BASE WATER PRESSURE DROP, WPDB (FT. H2O)
13	13.5	3.7
17	14.8	4.4
19	17.6	5.0
22 & 24	23.5	6.9
25 & 27	35.0	10.0
30	49.0	5.8
33	58.0	7.7
36 & 38	70.0	9.4
40 & 41	103.0	10.0
43 & 44	147.0	10.0

TABLE 5

WATER FLOW RATE/BASE WATER FLOW RATE (---)	ATR CORRECTION FACTOR, ATRF (---)	WPD CORRECTION FACTOR, WPDF (---)
1.5	1.040	2.25
1.2	1.020	1.44
1.0	1.000	1.00
0.8	0.965	0.64
0.6	0.910	0.36
0.5	0.860	0.26

SELECTION

Steam Units

1. Select FAS unit using combined boiler MBH output or HP from Table 1 for an FAS unit without filters, or Table 2 for an FAS unit with filters.
2. Read the base air temperature rise for steam units, BATRS, from Table 1 or 2.
3. Calculate the air temperature rise correction factor, ATRS: $ATRS = (SST - EAT) / 249.5$
where SST = Saturated steam temperature from Table 3 and EAT = Entering air temperature as given.
4. Calculate heat transfer, Q:
 $Q = 1.085 \times CFM \times ATRS \times BATRS$
where CFM = Airflow from Table 1 or 2.
5. Calculate the air temperature leaving the FAS unit, LAT: $LAT = EAT + (BATRS \times ATRS)$
6. Calculate the condensate load, CL:
 $CL = Q / LH$
where LH = Latent Heat from Table 3.

Example: Select FAS unit without filters for a set of two 91 HP boilers using 5 psig steam to heat outside air at -10 degrees F.

Solution:

1. For a combined boiler load of $2 \times 91 = 182$ HP, choose an FAS-22 from Table 1.
2. Also from table 1, BATRS = 96.0 degrees F for an FAS-22.
3. From Table 3, SST = 227.1 degrees F, so:
 $ATRS = (227.1 - (-10)) / 249.5 = 0.950$
4. $Q = 1.085 \times 2,750 \times 96.0 \times 0.950 = 272,100$ Btuh.
5. $LAT = -10 + (96.0 \times 0.950) = 81.2$ degrees F
From Table 3, LH = 960.4, so:
6. $CL = 272,100 / 960.4 = 283.3$ lb/hr.

Water Units

1. Select FAS unit using combined boiler MBH output or HP from Table 1 for an FAS unit without filters, or Table 2 for a unit with filters.
2. Read the base air temperature rise for water units, BATRW, from Table 1 or 2.
3. Calculate the air temperature rise correction factor, ATRW:
 $ATRW = (EWT - EAT) / 200$
where EWT = Entering water temperature as given and EAT = Entering air temperature as given.
4. Using the given water flow rate, calculate the ratio to Base Water flow Rate from Table 4.
5. Using the ratio of step 4, look up the Air Temperature Rise correction factor due to gpm, ATRF, from Table 5.
6. Calculate the Heat transfer, Q:
 $Q = 1.085 \times CFM \times (BATRW \times ATRW \times ATRF)$
where CFM = Airflow from Table 1 or 2.
7. Calculate the air temperature leaving the FAS unit, LAT:
 $LAT = EAT + (BATRW \times ATRW \times ATRF)$
8. Read the Base water Pressure Drop, WPD, Base from Table 4 for the unit selected.
9. Read the Water pressure Drop correction factor due to flow, WPDF, from Table 5 using the flow ratio of Step 4.
10. Calculate the water pressure drop, WPD:
 $WPD = (WPDB \times WPDF)$
11. Calculate the Water temperature Drop, WTD:
 $WTD = Q / (500 \times GPM)$

12. Calculate the leaving water temperature, LWT, using:
 $LWT = EWT - WTD$

Example: Select FAS unit with filters for a single 8,000 MBH output boiler using 42 gpm of 210 degrees F water to heat outside air at -5 degrees F.

Solution:

1. For a boiler load = 8,000 MBH output, choose an FAS-27 from Table 2.
2. Also from Table 2, BATRW = 67.4 degrees F for an FAS-27.
3. $ATRW = (210 - (-5)) / 200 = 1.075$
4. From Table 4, base water flow rate = 35 gpm.
 $Water\ flow\ rate / base\ water\ flow\ rate = 42 / 35 = 1.20$.
5. From Table 5 at Water flow rate / base water flow rate = 1.20: ATRF = 1.02.
6. $Q = 1.085 \times 4,500 \times (67.4 \times 1.075 \times 1.02) = 360,800$ Btuh.
7. $LAT = -5 + (67.4 \times 1.075 \times 1.02) = 68.9$ degrees F.
8. From Table 4 for FAS-27: WPDB = 10.0 feet H₂O.
9. From Table 5 at a water flow ratio of 1.20:
WPDF = 1.44.
10. $WPD = (10.0 \times 1.44) = 14.4$ feet H₂O.
11. $WTD = (360,800) / (500 \times 42) = 17.2$ degrees F.
12. $LWT = 210 - 17.2 = 192.8$ degrees F.

DIMENSIONS

Horizontal Units

C000607

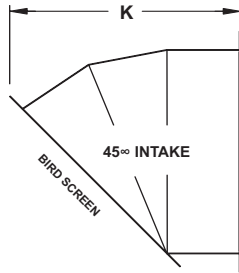

WALL INTAKE HOOD

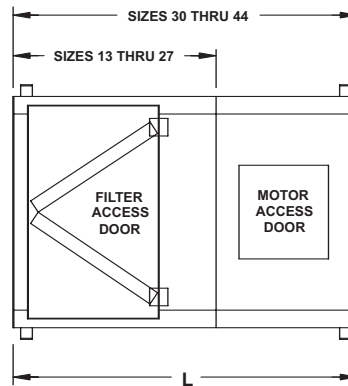

FILTER BOX

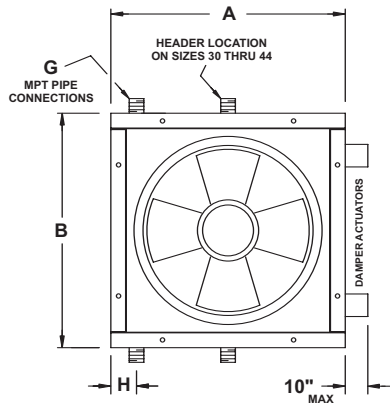

MODEL FASU
SAME FOR FASHCF
AND FASHCR

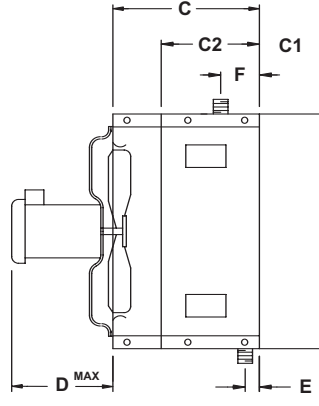

DIRECT DRIVE ASSEMBLY
SIZES 13 THRU 44
BELT DRIVE ALSO AVAILABLE
ON SIZES 30 THRU 44

C = STANDARD HEATER CASING DEPTH
C1 = OPTIONAL DISCHARGE DAMPER DEPTH
C2 = OPTIONAL SHORTDEPTH HEATER CASING

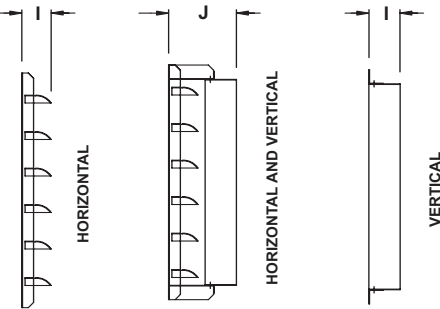

DISCHARGE LOUVER ASSEMBLY FURNISHED
AND MOUNTED ON THE UNIT AT THE FACTORY

FAS	DIMENSIONS													WEIGHTS				
	A	B	C	C1	C2	D	E	F	G	H	I	J	K	L	B1	B2	WI	FB
13	19 3/4	19 3/4	17	7	12	11 11/16	3 9/32	1 5/32	1 1/2	2 9/16	3 5/16	6 1/2	19 1/16	26 1/2	115	126	30	40
17	22 3/4	22 3/4	17	7 1/2	12	11 3/16	3 7/16	1 15/16	1 1/2	2 9/16	3 5/16	6 1/2	21 7/32	21	127	139	40	45
19	27 3/4	27 3/4	21	7 1/2	12	11 3/16	3 25/32	1 15/32	1 1/2	2 3/4	3 5/16	6 1/2	24 3/4	28	183	200	55	65
22	32 3/4	32 3/4	21	7	12	11 1/4	3 27/32	1 13/32	1 1/2	2 3/4	3 5/16	6 1/2	28 9/32	31	253	276	70	80
24	32 3/4	32 3/4	21	7	12	11 1/4	3 27/32	1 13/32	1 1/2	2 3/4	3 5/16	6 1/2	28 9/32	31	233	257	70	80
25	39 1/8	39 1/8	22	8	13	11 1/4	4 5/16	1 11/16	2	3 7/16	4 5/16	8 1/2	32 3/32	37	301	335	95	120
27	39 1/8	39 1/8	22	8	13	10 13/16	4 5/16	1 11/16	2	3 7/16	4 5/16	8 1/2	32 3/32	37	310	344	95	120
30	50 1/8	45 1/8	28	8	14	16 7/8	5 3/8	2	2 1/2	25 1/16	4 5/16	8 1/2	35 5/16	42	577	628	125	200
33	60 3/4	45 1/8	28	8	14	18 1/4	5 3/8	2	2 1/2	30 3/8	4 5/16	8 1/2	36 5/16	50	649	709	150	240
36	60 3/4	49 3/4	32 1/8	8	16	18 5/8	8 1/4	4 1/4	3	30 3/8	4 5/16	8 1/2	39 19/32	44	741	806	165	275
38	60 3/4	49 3/4	32 1/8	8	16	17 15/16	8 1/4	4 1/4	3	30 3/8	4 5/16	8 1/2	39 19/32	44	781	846	165	275
40	73	57	40	9	20	22 5/16	8 1/8	4 1/8	3	36 1/2	4 5/16	8 1/2	44 23/32	48	880	972	230	360
41	73	57	40	9	20	22 5/16	8 1/8	4 1/8	3	36 1/2	4 5/16	8 1/2	44 23/32	48	880	972	230	360
43	73 1/8	80 1/4	44	9	20	23 13/16	8 1/8	4 1/8	3	36 9/16	4 5/16	8 1/2	61 9/32	50	1,636	1,748	365	445
44	73 1/8	80 1/4	44	9	20	22 1/16	8 1/8	4 1/8	3	36 9/16	4 5/16	8 1/2	61 9/32	50	1,671	1,783	365	445

Notes:

- All dimensions in inches.
- All weights in pounds.
- Weight nomenclature: B1 = Base Horizontal Unit with Horizontal or Vertical blade discharge; B2 = Base Horizontal Unit with Horizontal and Vertical blade discharge; WI = Wall Intake; FB = Filter Box.

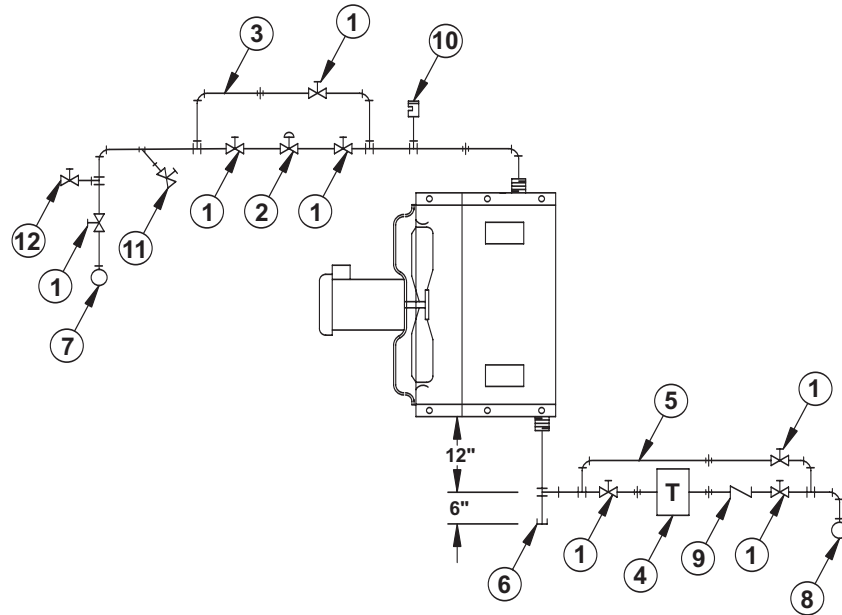

STEAM PIPING LEGEND (FOR GRAVITY ATMOSPHERIC RETURN SYSTEMS)

- | | |
|--|--|
| 1. GLOBE OR GATE VALVE | 7. STEAM SUPPLY MAIN. |
| 2. OPTIONAL MOTORIZED SHUT-OFF VALVE | 8. CONDENSATE RETURN MAIN. |
| 3. BY-PASS TO ALLOW SERVICING OF MOTORIZED VALVE.
BYPASS LINE TO BE THE SAME SIZE AS MOTORIZED VALVE. | 9. 15° SWING CHECK VALVE. |
| 4. INVERTED BUCKET OR COMBINATION FLOAT AND THERMOSTATIC TRAP WITH VENT. | 10. 1/2" SPRING LOADED VACUUM BREAKER VENTED TO ATMOSPHERE. |
| 5. BY-PASS TO PERMIT SERVICING OF TRAP. BY-PASS TO BE ONE PIPE SIZE LARGER THAN TRAP ORIFICE. | 11. STEAM STRAINER WITH BLOW-DOWN VALVE. |
| 6. DIRT POCKET AND DRIP LEG. TO BE THE SAME SIZE AS THE HEATER CONDENSATE RETURN LINE. | 12. 1/2" DRAIN VALVE. TO BE OPENED WHEN GLOBE OR GATE SHUTOFF VALVE IS CLOSED. |

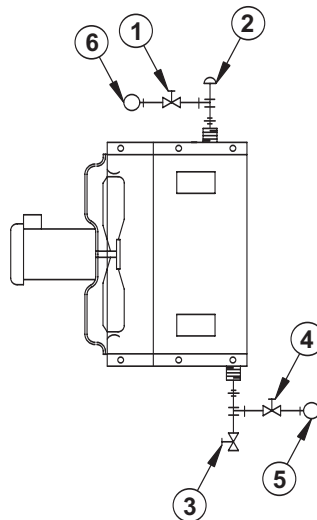

HOT WATER PIPING LEGEND

- | | |
|------------------------|-----------------------------|
| 1. GLOBE OR GATE VALVE | 4. WATER FLOW CONTROL VALVE |
| 2. AUTOMATIC AIR VENT | 5. HOT WATER SUPPLY LINE |
| 3. COIL DRAIN VALVE | 6. HOT WATER RETURN LINE |

CONTROLS

Temperature Control Systems

Methods of Control

The FAS is available with either of two methods of temperature control: Airstream or Room with Low Limit. Both methods control the discharge temperature of the unit by modulating the face and bypass dampers. With Airstream control, the controller is mounted on the unit and has a single sensing element located in the discharge airstream. Room with Low Limit control uses the Airstream controller as its low limit and adds a room thermostat as the primary control.

Pneumatic or Electric Actuators

Both methods of temperature control are available in either electric or pneumatic versions. The standard electric version uses direct-coupled 24 volt Belimo damper actuators with Viconics controllers. The standard pneumatic version uses Siemens actuators. Consult factory for availability of controls by other manufacturers.

Controller Setpoints

The FAS heater is a make-up air system and, as such, the delivered air temperature should be at or near that of the boiler room ambient temperature. With Room with Low Limit control, this insures that if the Room thermostat is satisfied, the Low Limit controller will not allow the unit discharge to fall below the desired temperature. Without this, or if the Low Limit were set well below the Room, unheated air could be introduced into the boiler room, driving the ambient temperature down and requiring the unit to bring it back up. The Room with Low limit Control prevents this unwanted temperature cycling.

Sequence of Operation

When maximum temperature rise is required, the face dampers are fully open to the heating sections while the bypass dampers are fully closed. With electric actuators, as the discharge temperature approaches the controller setpoint, the bypass dampers will begin to open. Once the bypass dampers are fully open, if even less temperature rise is required, the face dampers will begin to close. With pneumatic actuators, as the discharge temperature approaches the controller setpoint, the bypass dampers will begin to open while the face dampers begin to close.

Shutoff Feature

For units equipped with electric damper actuators, when the unit is shut down, both the face and bypass dampers close to prevent the infiltration of cold outside air. There is no need for a separate motorized shutoff damper. However, for units equipped with pneumatic damper actuators, when the unit is shut down, the face dampers open and the bypass dampers close. A separate motorized shutoff damper is therefore needed to prevent the infiltration of cold outside air.

Additional Control Options

Included among the additional temperature control options are:

- Freezestat – Uses an averaging sensing element mounted to one heating element to shut down the unit upon sensing a temperature that could potentially lead to a frozen tube or coil.
- Fan Cut-Off Thermostat - Uses a single sensing bulb to shut down the unit upon sensing a temperature that could potentially lead to a frozen tube or coil.
- Discharge Dampers – Can be installed on the leaving side of the face sections to minimize temperature override.

CONTROLS

Temperature Control Arrangements

C000608

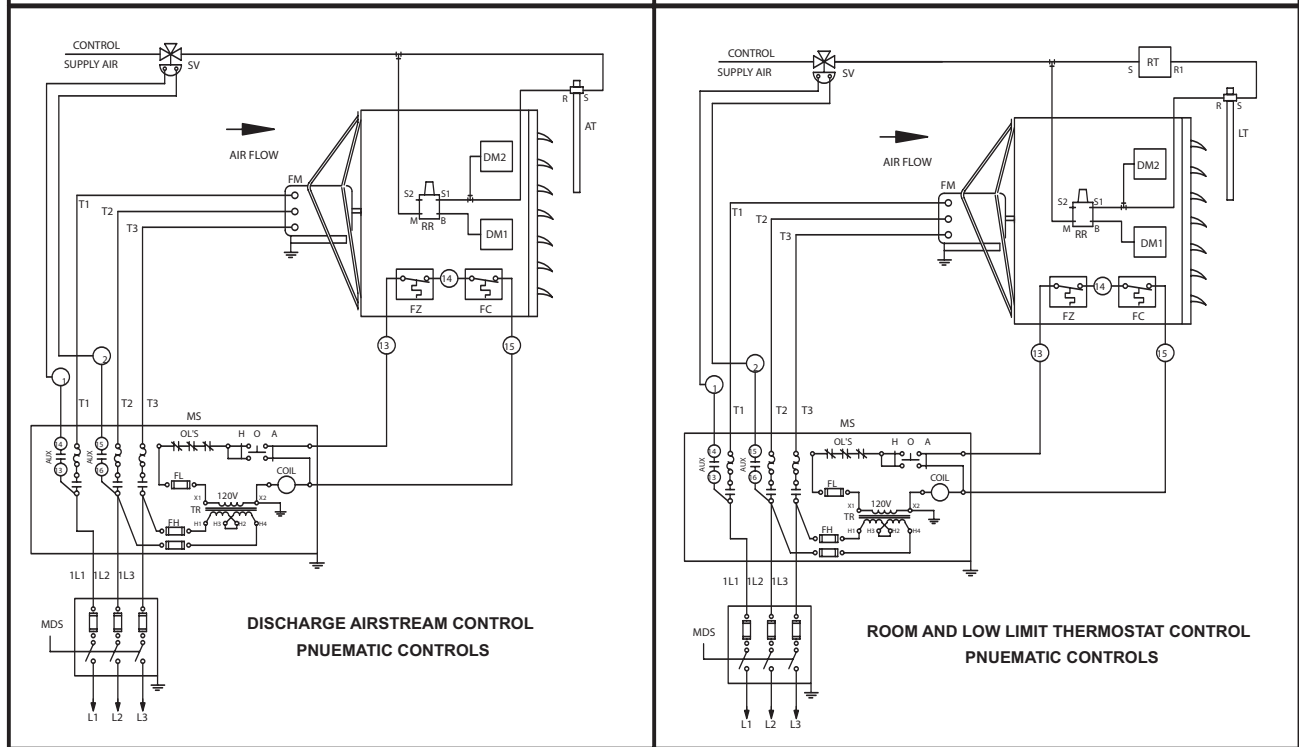
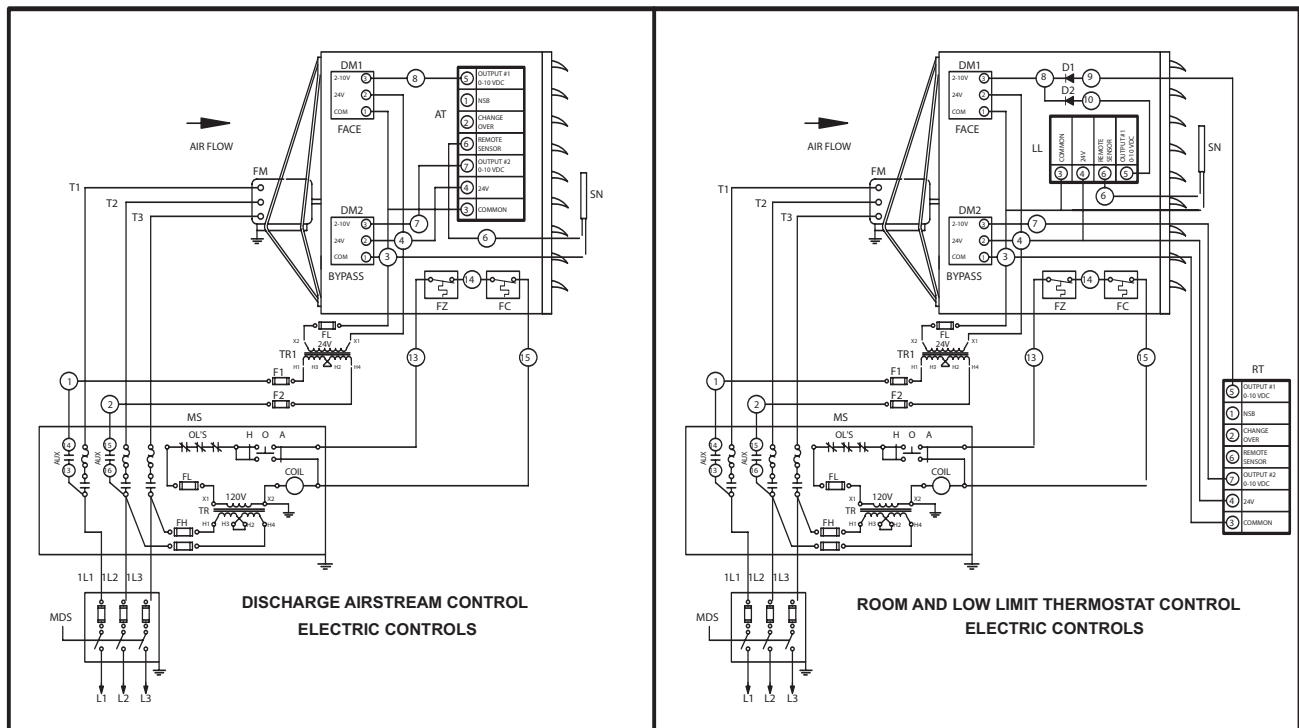

AT AIRSTREAM THERMOSTAT
 D1, D2 DIODES
 DM1 FACE DAMPER MOTOR
 DM2 BYPASS DAMPER MOTOR
 F1, F2 FUSE
 F3 FUSE - REVOLVING DISCHARGE MOTOR
 FC MOTOR CUT-OFF THERMOSTAT
 FH FUSE

FL FUSE
 FM SUPPLY AIR FAN MOTOR
 FZ FREEZESTAT
 LL LOW LIMIT THERMOSTAT - ELECTRIC
 LT LOW LIMIT THERMOSTAT - PNEUMATIC
 MDS FUSED MAIN DISCONNECT SWITCH
 MS MOTOR STARTER
 RDM REVOLVING DISCHARGE MOTOR

RR POSITIVE POSITIONER - PNEUMATIC
 RT ROOM THERMOSTAT
 SN AIR DISCHARGE SENSOR
 SV THREE WAY CONTROL AIR SOLENOID PRESSURETROL
 TP1 AQUASTAT
 TR1 24 VOLT TRANSFORMER
 TR 120 VOLT TRANSFORMER

CONTROLS

Airflow Control Systems

As standard, the FAS unit provides a constant flow of heated fresh air for combustion. For applications where it is desired to vary the intake of outside air in conjunction with the firing rate of the boiler(s), four methods of outside airflow control are available. These methods are described below; schematics of each are shown on the following page. In all cases, it may also be necessary to use a different motor and fan blade depending on the total system static pressure.

Method #1: Two-Speed Motor

FAS units are available with optional two-speed motors and two-speed motor controllers so that two stages of airflow control can be achieved. Such an approach might be desirable, for example, on a single boiler application with hi-low firing rates. Two-speed motors are only available as an option on belt-driven FAS sizes 28 and larger.

Method #2: Mixing Box

With the installation of a mixing box upstream of the FAS tied to a room pressure transducer, the outside air can be varied in proportion to the demand for combustion air from the boiler(s). When all boilers are at high fire, the damper for the return air is full closed and the outside air damper is full open to maintain the desired room pressurization.

Method #3: Variable Frequency Drive

With a variable frequency drive attached to the FAS motor, the motor speed and hence the delivery of outside air can readily be modulated through a room pressure transducer as the demand for combustion air changes. Variable frequency drives can also be programmed for multiple, specific fan rpm ratings.

Method #4: Multiple FAS units

Yet another approach to airflow control is the use of multiple FAS units, with perhaps each FAS unit serving the combustion airflow needs of a single boiler. This method offers the additional benefit of providing redundancy in the unlikely event of FAS unit failure.

CONTROLS

Airflow Control Arrangements

D000740

**METHOD #1
2-SPEED MOTOR**

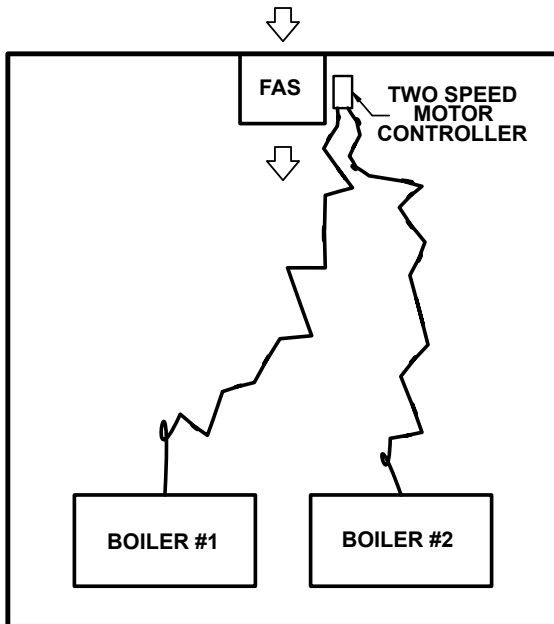

**METHOD #2
MIXING BOX**

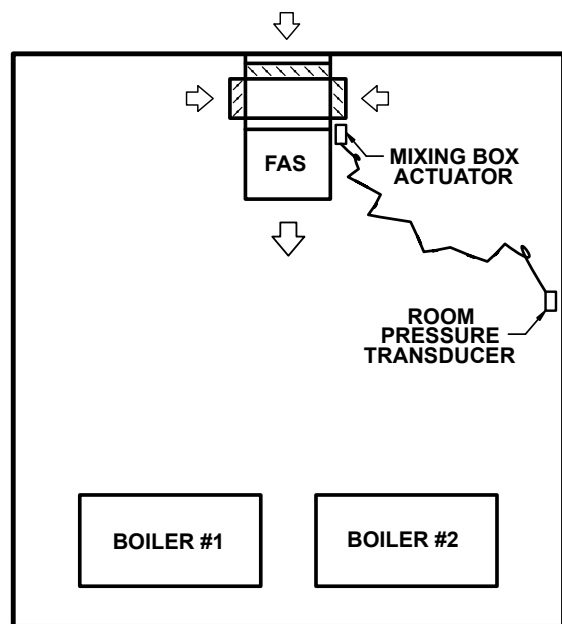

**METHOD #3
VARIABLE FREQUENCY DRIVE**

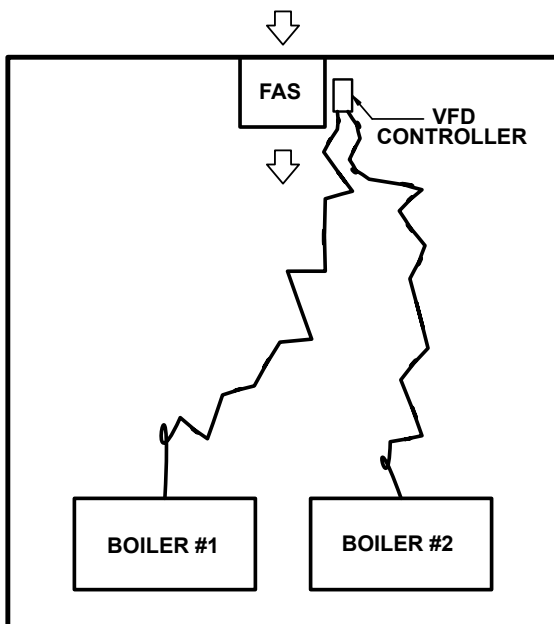

**METHOD #4
MULTIPLE FAS**

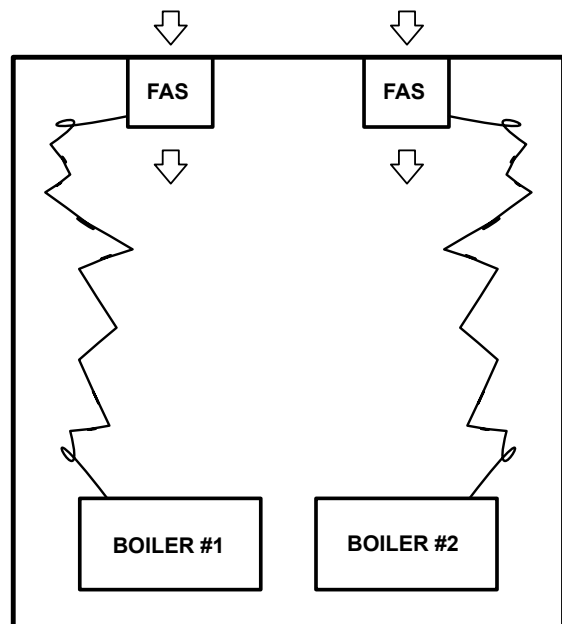

TYPICAL SPECIFICATION AND SCHEDULE

Typical Specification

General

Furnish a factory-assembled FAS model combustion air preheater as manufactured by L.J. Wing, Dallas, TX, to heat outside air for the boiler room. Performance shall be as shown in the schedule. Unit shall be capable of maintaining discharge air temperature regardless of fluctuations in inlet air temperature. Each unit shall consist of a heater section containing an integral face and bypass coil consisting of built-in multiple alternate finned heating elements and bypasses. Separate dampers shall control the airflow through these face and bypass sections. Each set of dampers shall be interlocked and controlled by a separate electric or pneumatic damper motor as scheduled.

Finned heating elements shall be fabricated of seamless return bend type 3/8" o.d. copper tubes with rectangular 0.010" thick aluminum fins. Each tube shall be secured to the headers by a brazed joint. The opposite end of the tubes shall be secured by channel-shaped retainers that permit expansion and contraction. Finned elements shall be factory tested with 200 psig steam and 500 psig hydrostatic pressure. Unit shall have a propeller type fan blade driven by a TEFC motor with characteristics as scheduled. Casing and discharge shall be constructed of galvanized sheet metal. Unit casing and discharge shall be painted inside and out with an air-dried alkyd enamel finish.

Temperature Controls

Unit shall be furnished with _____ (indicate either "Airstream Control with a thermostat to provide a constant discharge temperature regardless of inlet air temperature fluctuations", or "Room with Low Limit Control having a room thermostat and overriding low limit thermostat to prevent the unit's discharge temperature from falling below the desired minimum.")

Discharge

Unit shall have a discharge consisting of _____ (indicate either "horizontal vanes for maximum horizontal airflow projection"; "vertical vanes for maximum airflow spread"; or "horizontal and vertical vanes for adjustable airflow projection and spread").

Airflow Controls (optional)

2-Speed Motor (optional)

Unit shall be furnished with a two-speed motor controller to provide two steps of airflow control in response to the boiler(s) firing rate.

Mixing Box (optional)

A mixing box shall be furnished upstream of the unit to proportion the amount of room air and outside air through the heater in response to a signal from a room pressure transducer.

Variable Frequency Drive (optional)

The unit shall be fitted with a variable speed drive to vary the fan speed in response to the firing rate of the boiler(s).

Multiple Heaters (optional)

Multiple heaters shall be furnished to vary the amount of boiler combustion air in response to the boiler(s) firing rate.

Intake Hood (optional)

Unit shall be furnished with an intake hood fashioned of heavy gauge sheet steel with 45 angular degree overhang and turned-up flange to prevent water from entering the unit. Intake shall be covered with a bird screen to keep out animals and debris.

Filter Box (optional)

Unit shall be equipped with a filter box fabricated of heavy gauge sheet steel, complete with _____ (indicate "throwaway" or "cleanable") filters.

Typical Schedule

Model no.	Airflow Rate (scfm)	Ent. Air Temp. (degrees F)	Leav. Air Temp. (degrees F)	Steam Pressure (psig)	Condensate load (lbm/hr)	External S.P. (inches w.c.)	Electrical Service (volt/ph./Hz)	Motor Horsepower (HP)
FAS-22	2,750	-10	81.0	5	282.9	0	208/3/60	1/4

