

IFB Coil Technical Guide



**HORIZONTAL TUBE INTEGRAL FACE AND BY-PASS HEATING COILS
FOR AIR PREHEATING**

Since 1875, the L.J. Wing Company has been a leader in providing innovative solutions for difficult HVAC problems. Wing IFB integral face and by-pass coils provide reliable air preheating for air handling systems. This technical guide will help you size, select and specify the proper IFB model to satisfy your project's make-up air preheating requirements. If you have questions, please contact your local L.J. Wing representative; he will be glad to assist you.



4830 Transport Drive, Dallas, TX 75247 Tel. (214) 638-6010 Fax (214) 905-0806
www.ljwing.com

In the interest of product improvement, L.J. Wing reserves the right to make changes without notice.

TABLE OF CONTENTS

Operation.....4
Performance.....5
Model Number Description.....5
Dimensions.....6-7
Piping.....8-16
Controls.....17
Installation Tips.....18
Accessories.....19
Typical Specification.....20
Typical Schedule.....20

OPERATION

How the IFB Coil Works

L.J. Wing pioneered the development of the first integral face and bypass coil in the early 1960's as a solution to providing effective outside air preheating in sub-freezing temperatures. Prior air preheat systems typically employed either modulating valves or coils with external face and bypass dampers to control preheat temperature. Wing's integral face and bypass coil operates with full steam or water flow, thereby eliminating the cost and freezing hazard of modulating valves. With Wing's design concept, accurate final air temperature is achieved by proportioning the air, rather than by modulating the steam pressure or water flow. As shown in the schematic below, Wing's concept consists of a number of alternate heating passages and by-pass passages.

Full steam or water flow is maintained in the heated, or "face", section at all times, while air flowing through the bypass passages is not heated. As the temperature of the entering air varies, a thermostat located in the discharge air stream responds by adjusting the position of the dampers to maintain the correct proportioning of air through the face and bypass channels necessary to keep the discharge air temperature constant. The thin strata of heated and unheated air mix thoroughly and rapidly within three feet downstream of the coil. Potential freezing or nuisance freezestat trip-outs associated with external face and bypass coil systems are thereby eliminated.

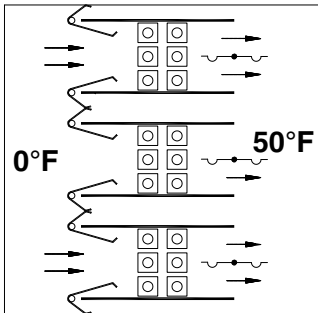

For 0° Entering Air

The damper blades are completely open to the face to allow maximum temperature rise.

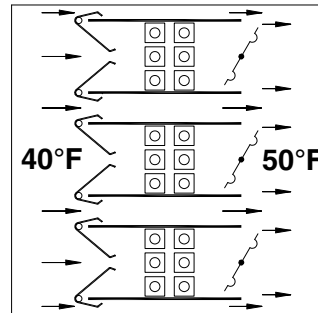

For 40° Entering Air

The damper blades are mostly closed to the face, allowing more bypass air than face air to achieve the desired leaving air temperature.

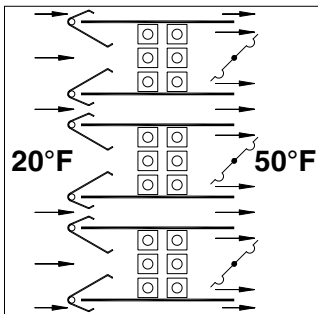

For 20° Entering Air

The damper blades are partially closed to the face, allowing the proper proportions of face and bypass air to achieve the desired leaving air temperature.

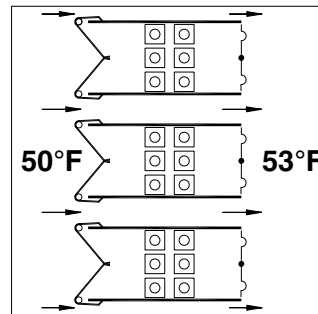

For 50° Entering Air

The clamshell damper blades are completely closed to allow full bypass airflow with minimum temperature override.

PERFORMANCE AND CERTIFICATION

Performance

Performance ratings for IFB coils can be obtained from the L.J. Wing Coil Specifier program that can be downloaded from the L.J. Wing website: www.ljwing.com

With a menu-driven format, the Coil Specifier program is quick and simple to use. Input and output values are conveniently shown on a single screen, enabling you to instantaneously evaluate the effect of changing input variables such as fin spacing or coil size.

The Specifier program offers two printed reports: "Coil Rating" and "Specification". The "Coil Rating" report includes not only the coil performance rating, but also a dimensional drawing and piping diagram. The "Specification" report generates a dynamic specification for the coil selected.

Along with the IFB series, L.J. Wing's other two integral face and bypass coil product lines, the VIFB and MV series, may be also selected and rated with the Coil Specifier.

Certification



Wing IFB coil performance generated with the Wing Specifier program is certified by the Air-Conditioning, Heating, and Refrigeration Institute (AHRI) under AHRI Standard 410. Having the AHRI label provides assurance that AHRI certifies the accuracy of the IFB coil performance ratings. To earn and maintain AHRI certification, randomly selected IFB coils must annually pass through the AHRI design performance certification process. For best performance, always select an AHRI-certified coil.

All L.J. Wing IFB coils are listed by Engineering Test Laboratories (ETL) to Underwriters' Laboratories (UL) Standard 1995. This standard assures that IFB coils are safe to operate up to a design pressure of 100 psig. The standard further stipulates that each coil must withstand a hydrostatic pressure equal to five times the rated design pressure, such that each IFB coil is hydrostatically tested to 500 psig. For quality products, always look for the ETL mark.

Model Number Description

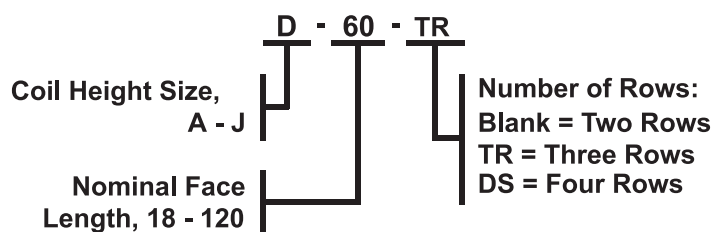

DIMENSIONS

Steam and Hot Water Coils – Side Headers

D000722

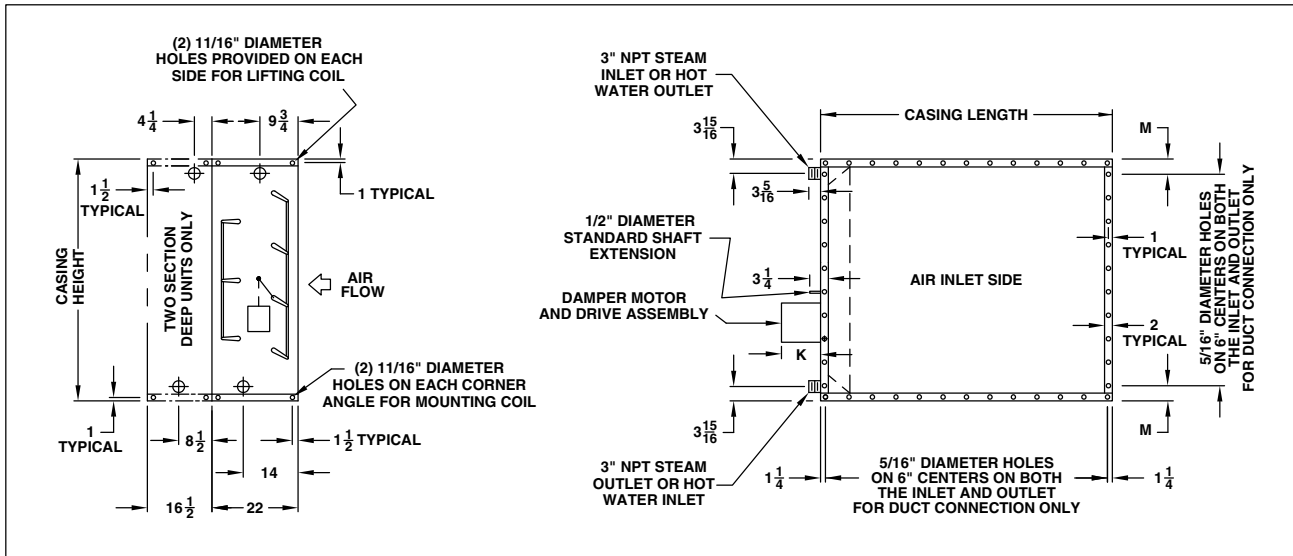

NOTES :

- (1) LEFT HAND DAMPER MOTOR LOCATION IS STANDARD. RIGHT HAND LOCATION IS OPTIONAL.
- (2) COIL CONNECTIONS AND DAMPER MOTOR MUST BE ON THE SAME SIDE.
- (3) TWO (2) AND THREE (3) ROW COILS HAVE A SINGLE SECTION. FOUR (4) ROW COILS HAVE TWO SECTIONS.
- (4) DIMENSION 'K' FOR A FOOT MOUNTED ACTUATOR IS 10". DIMENSION 'K' FOR A DIRECT COUPLED ACTUATOR IS 5".

SIZE			18		24		30		36	
CASING LENGTH			26.5		32.5		38.5		44.5	
SIZE	CASING HEIGHT	M	OA	WT	OA	WT	OA	WT	OA	WT
A	20.750	4.375	2.04	180	2.74	205	3.44	223	4.14	245
B	29.125	5.563	3.06	240	4.11	265	5.16	291	6.21	315
C	37.500	3.750	4.09	303	5.48	333	6.88	361	8.27	385
D	45.875	2.938	-	-	6.85	405	8.60	430	10.3	455
E	54.250	3.125	-	-	-	-	10.3	493	12.4	525
F	62.625	4.313	-	-	-	-	12.0	553	14.5	595
G	71.000	5.500	-	-	-	-	-	-	16.6	665
H	79.375	3.688	-	-	-	-	-	-	-	-
J	87.750	4.875	-	-	-	-	-	-	-	-

SIZE			42		48		54		60	
CASING LENGTH			50.5		56.5		62.5		68.5	
SIZE	CASING HEIGHT	M	OA	WT	OA	WT	OA	WT	OA	WT
A	20.750	4.375	4.84	267	5.55	289	6.23	312	6.93	335
B	29.125	5.563	7.25	341	8.30	367	9.35	386	10.4	431
C	37.500	3.750	9.67	415	11.1	445	12.5	482	13.9	517
D	45.875	2.938	12.1	491	13.8	533	15.6	575	17.3	613
E	54.250	3.125	14.5	567	16.6	613	18.7	662	20.8	709
F	62.625	4.313	16.9	641	19.4	693	21.8	752	24.3	805
G	71.000	5.500	19.3	716	22.1	773	24.9	832	27.7	901
H	79.375	3.688	21.7	791	24.9	853	28.0	912	31.1	997
J	87.750	4.875	-	-	27.6	933	31.1	992	34.6	1,093

Notes:

1. OA = Outlet Area in square feet, WT = Weight in pounds.
2. All dimensions in inches.
3. Table weights apply to two row coils only; for three row coils, multiply table weight by 1.06; for four row coils, multiply table weight by 1.7.

DIMENSIONS

Steam and Hot Water Coils – Size 66-120

D000723

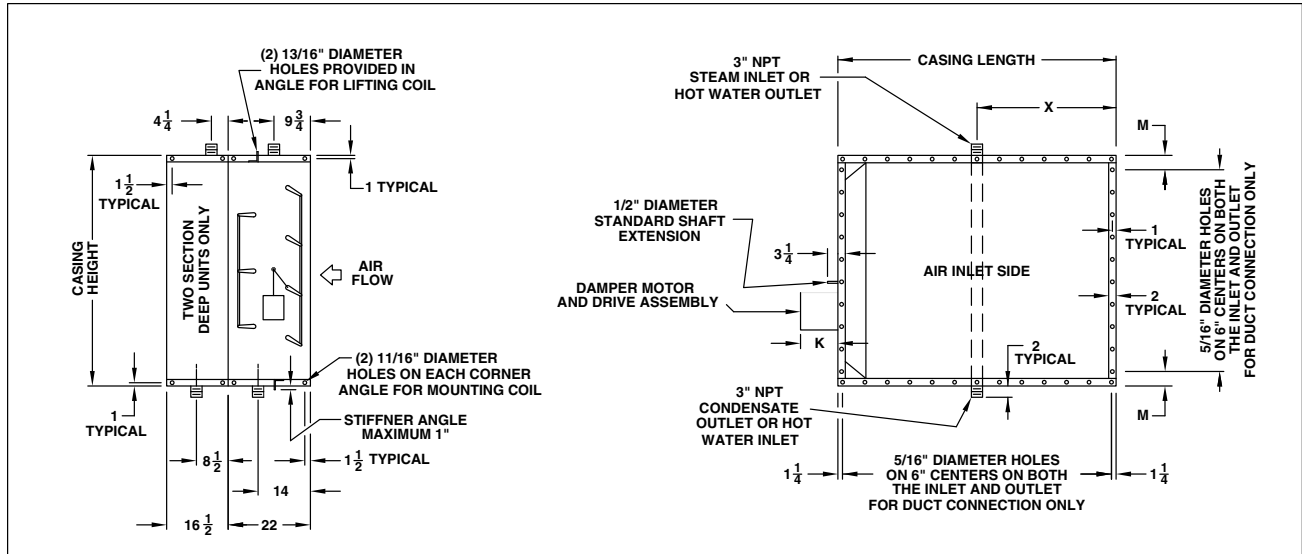

NOTES :

- (1) LEFT HAND DAMPER MOTOR LOCATION IS STANDARD. RIGHT HAND LOCATION IS OPTIONAL.
- (2) TWO (2) AND THREE (3) ROW COILS HAVE A SINGLE SECTION. FOUR (4) ROW COILS HAVE TWO SECTIONS.
- (3) DIMENSION 'K' FOR A FOOT MOUNTED ACTUATOR IS 10". DIMENSION 'K' FOR A DIRECT COUPLED ACTUATOR IS 5".

SIZE			66		72		78		84		90	
CASING LENGTH			74.50		80.50		86.50		92.50		98.50	
X			37.25		40.25		43.25		46.25		49.25	
SIZE	CASING HEIGHT	M	OA	WT	OA	WT	OA	WT	OA	WT	OA	WT
A	20.750	4.375	7.63	379	8.32	408	9.02	434	9.72	460	10.4	486
B	29.125	5.563	11.4	481	12.5	517	13.5	553	14.60	589	15.6	624
C	37.500	3.750	15.3	583	16.7	626	18.0	670	19.40	715	20.8	761
D	45.875	2.938	19.1	685	20.8	741	22.6	797	24.3	852	26.1	907
E	54.250	3.125	22.9	797	25.0	860	27.1	923	29.2	986	31.3	1,048
F	62.625	4.313	26.7	899	29.1	979	31.6	1,055	34.0	1,128	36.5	1,203
G	71.000	5.500	30.5	1,015	33.3	1,098	36.1	1,181	38.9	1,263	41.7	1,346
H	79.375	3.688	34.3	1,131	37.4	1,217	40.6	1,307	43.7	1,398	46.8	1,489
J	87.750	4.875	38.1	1,247	41.6	1,336	45.1	1,433	48.6	1,533	52.1	1,632

SIZE			96		102		108		114		120	
CASING LENGTH			104.50		110.50		116.50		122.50		128.50	
X			52.25		55.25		58.25		61.25		64.14	
SIZE	CASING HEIGHT	M	OA	WT	OA	WT	OA	WT	OA	WT	OA	WT
A	20.750	4.375	11.1	513	11.8	539	12.5	565	13.2	591	13.9	617
B	29.125	5.563	16.7	660	17.7	696	18.8	732	19.8	767	20.9	803
C	37.500	3.750	22.2	807	23.6	852	25.0	898	26.4	943	27.8	989
D	45.875	2.938	27.8	963	29.5	1,019	31.3	1,074	33.0	1,130	34.8	1,175
E	54.250	3.125	33.4	1111	35.4	1,174	37.5	1,236	39.6	1,299	44.7	1,361
F	62.625	4.313	38.9	1279	41.4	1,353	43.8	1,422	46.2	1,491	48.7	1,547
G	71.000	5.500	44.5	1,428	47.3	1,512	50.1	1,594	52.8	1,677	55.6	1,753
H	79.375	3.688	50.0	1,577	53.1	1,671	56.3	1,766	59.4	1,863	62.5	1,959
J	87.750	4.875	55.5	1,726	59.0	1,830	62.5	1,938	66.0	2,049	69.5	2,165

Notes:

1. OA = Outlet Area in square feet, WT = Weight in pounds.
2. All dimensions in inches.
3. Table weights apply to two row coils only; for three row coils, multiply table weight by 1.06; for four row coils, multiply table weight by 1.7.

Recommendations

The integrity of the system depends in part on proper piping. The following recommendations should be diligently observed:

Steam Systems

1. All piping in contact with airflow or inside an air handler should be insulated.
2. Install the casing level; tubes are pitched within casing to provide proper condensate drainage.
3. Full steam pressure must be supplied to the coil at all times; modulating valves must not be used.
4. Steam mains, return mains and traps should be anchored and supported independently of the IFB coil.
5. A drip trap should be installed in the steam supply line and drip into the return main. This will prevent steam line condensate from entering the unit with the steam. Avoid dripping steam mains into the IFB coil or into the line between the IFB coil and traps.
6. Use only bucket or float and thermostatic traps for condensate removal. Thermostatic traps should be used for venting only.
7. Steam traps should be sized for three times the calculated condensate loading at the coil design conditions, based on the pressure differential across the trap rather than the boiler pressure. Each trap should be selected for the actual pressure differential across the trap, not the boiler pressure. Pressure differential is herein defined as the gauge pressure at the trap minus the pressure in the return main.
8. The return connection should be full size of the coil header and reduced at the trap. Use of a reducing bushing on the coil return connection is not recommended. (If shutoff valve, strainer and trap are piped together with pipe nipples, then the pipe can be reduced to the trap inlet size at the shutoff valve).
9. Strainers should be installed ahead of traps to prevent dirt and sludge from affecting trap operation.
10. When the "closed circuit gravity return system" leads directly to the boiler, the coil traps should be located at least two feet above the water line of the boiler.
11. Risers should not be installed in condensate return lines.
12. Each coil in a coil bank or in series should be individually trapped and vented.
13. The steam trap should have provisions for air venting. If the trap is non-venting, proper air vents should be provided for each coil section to eliminate condensable gases. All air vent lines should be minimum one-inch diameter and properly pitched to assure free venting of air. The venting device should be located at least 12 inches above the bottom of the coil casing. In low-pressure steam systems (15 psig and below) in which a non-venting trap is used for condensate removal, a thermostatic air trap should be installed in a one-inch diameter air line bypassing the condensate trap to the atmospheric return main. An automatic air vent should be installed in a one-inch diameter air line before the condensate trap on systems with a vacuum return system. In high-pressure steam systems (above 15 psig) in which a non-venting trap is used for condensate removal, an automatic air vent should be installed in a one-inch diameter air line before the condensate trap. Do not return vented air to the condensate return main.
14. A bypass line with valve should be installed around the trap to permit operation of the coil during trap maintenance. This feature will also provide better coil start-up conditions when temperatures are below freezing.
15. If condensate must be lifted above the coil return level into overhead mains or if return mains are pressurized, then a pump and receiver should be installed between the condensate traps and return mains.
16. Proper vacuum breakers should be furnished as shown on the piping diagrams.
17. Swing check valves of 15-degree type should be utilized to prevent condensate backup in the case of steam system failure. Vertical lift check valves or 45-degree swing check valves should not be used as they require a higher head pressure of water for opening.

Hot Water Systems

1. Install the casing level; tubes are pitched within the casing to provide proper water drainage.
2. Inlet and outlet mains should be anchored and supported independently of the IFB coil.

PIPING DIAGRAM

Two Row Steam Coils – Size 18-60

W10

STEAM PRESSURE BELOW 15 PSIG OR 103.4 KPA

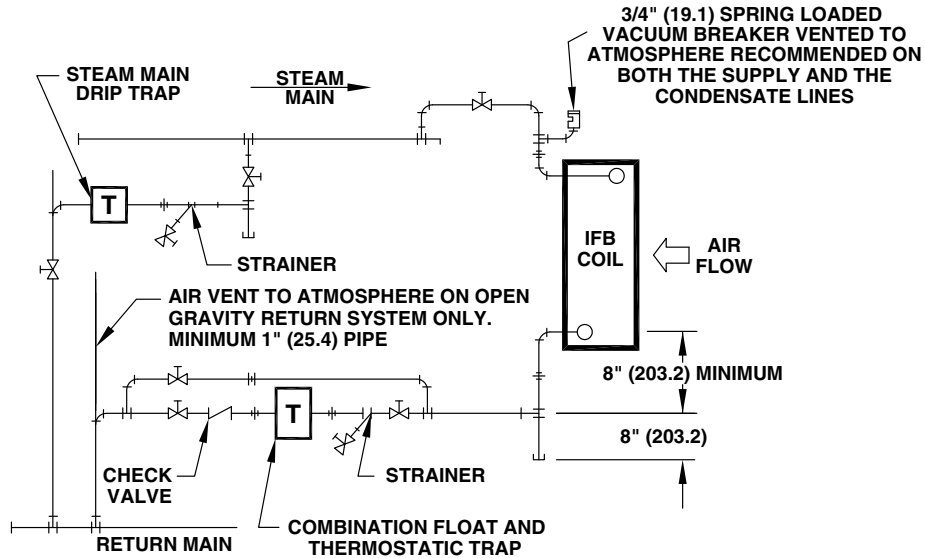

Non-venting Traps
(Steam Pressure Below 15 PSIG Or 103.4 kPa)

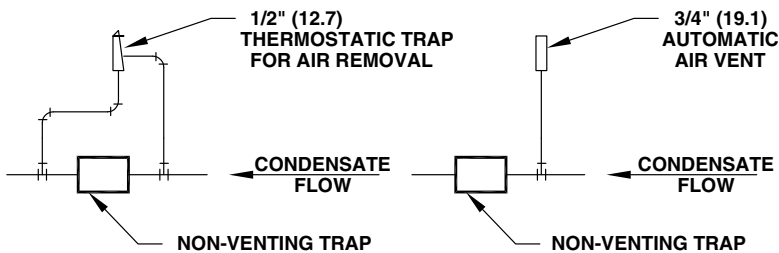

STEAM PRESSURE ABOVE 15 PSIG OR 103.4 KPA

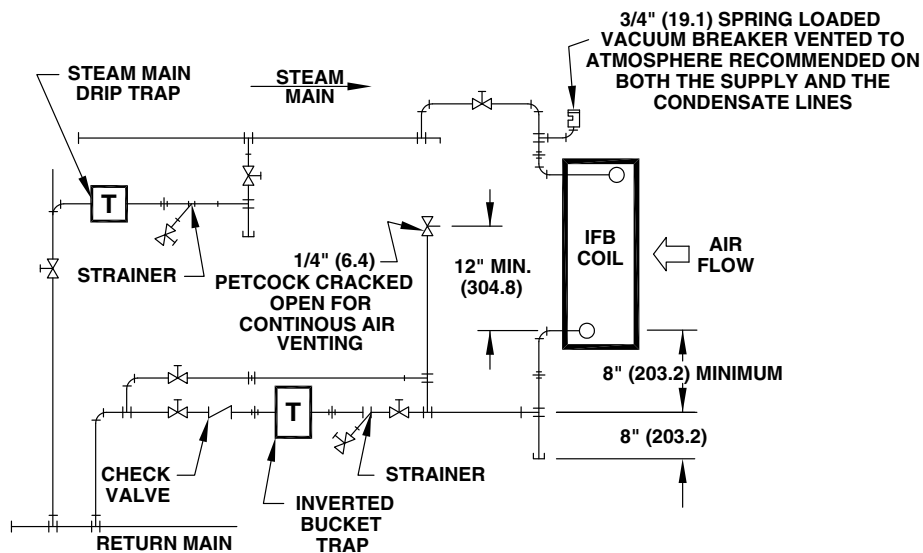

NOTE : DIMENSIONS ARE IN INCHES.
DIMENSIONS IN PARENTHESIS ARE IN MILLIMETERS.

PIPING DIAGRAM

Two Row Steam Coils – Size 66-120

W16

STEAM PRESSURE BELOW 15 PSIG OR 103.4 KPA

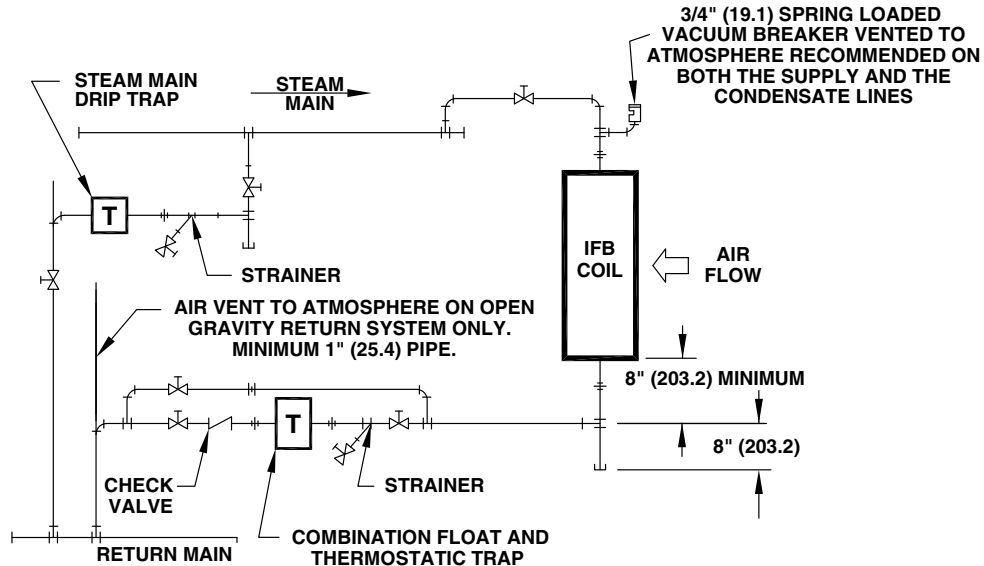

Non-venting Traps
(Steam Pressure Below 15 PSIG Or 103.4 KPa)

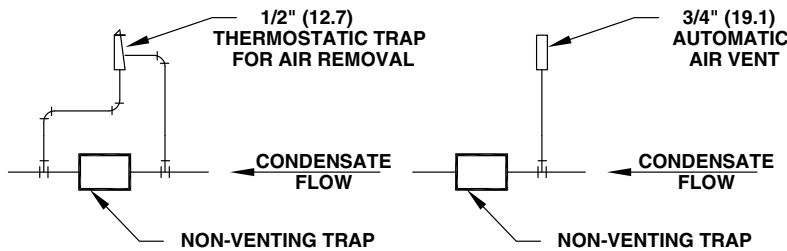

STEAM PRESSURE ABOVE 15 PSIG OR 103.4 KPA

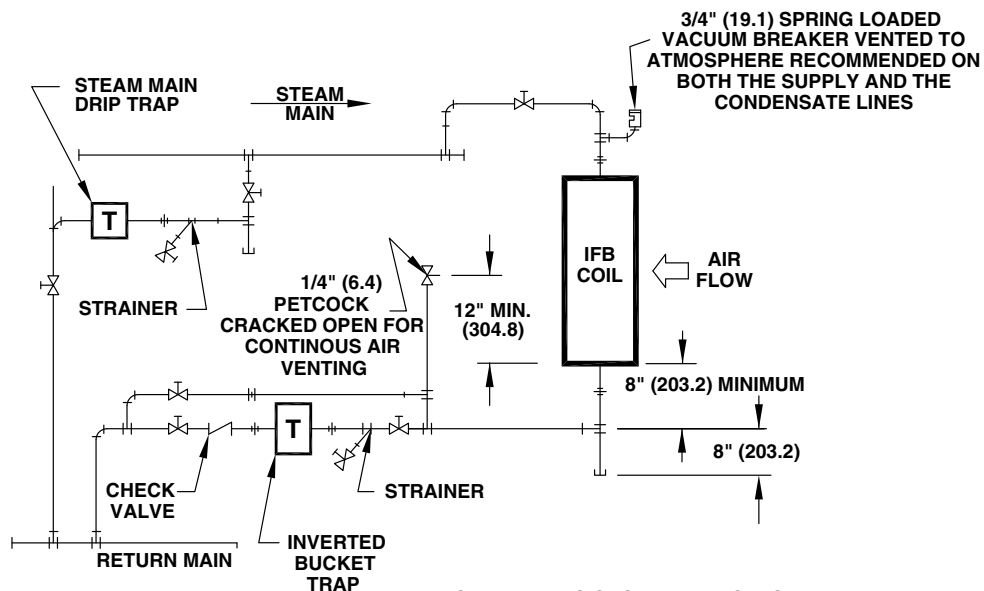

NOTE : DIMENSIONS ARE IN INCHES.
DIMENSIONS IN PARENTHESIS ARE IN MILLIMETERS.

PIPING DIAGRAM

Four Row Steam Coils – Below 15 psig – Size 18-60

W14

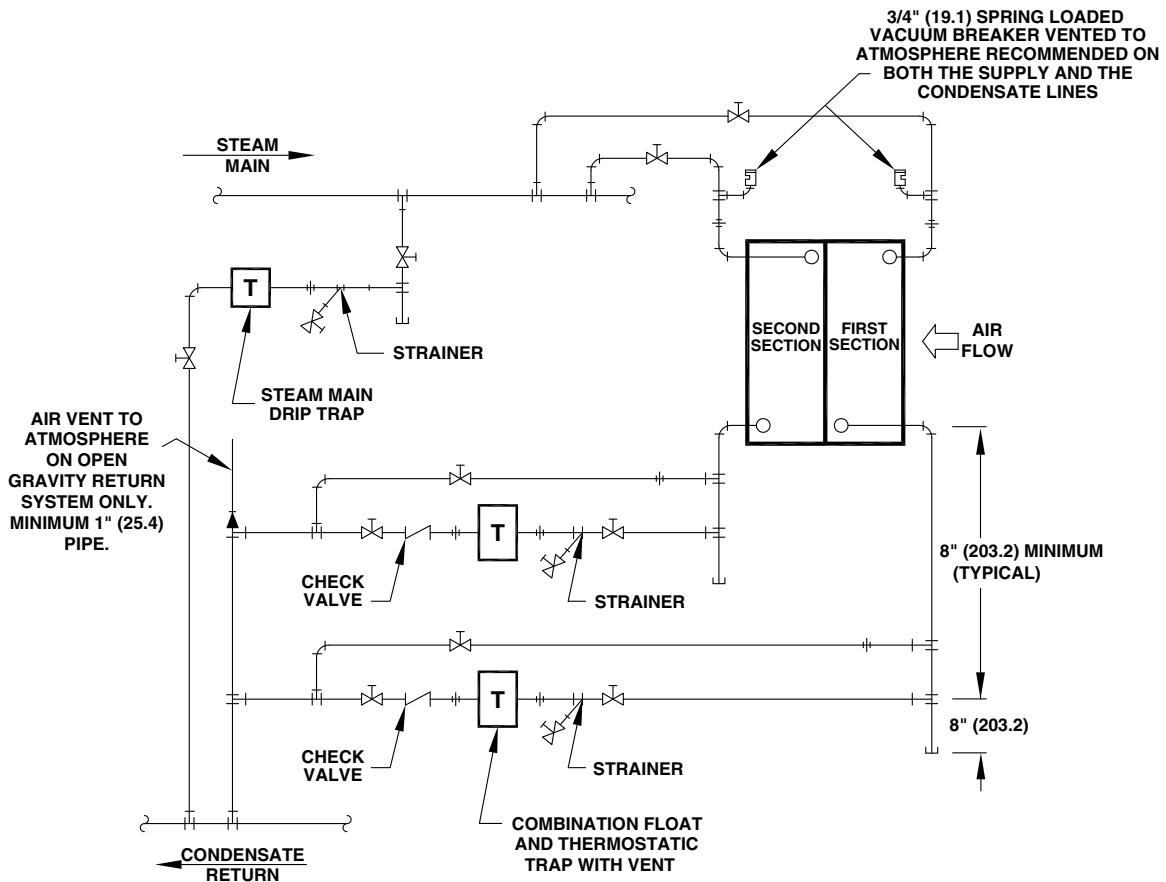

Additional Piping Required For Non-Venting Type Steam Traps

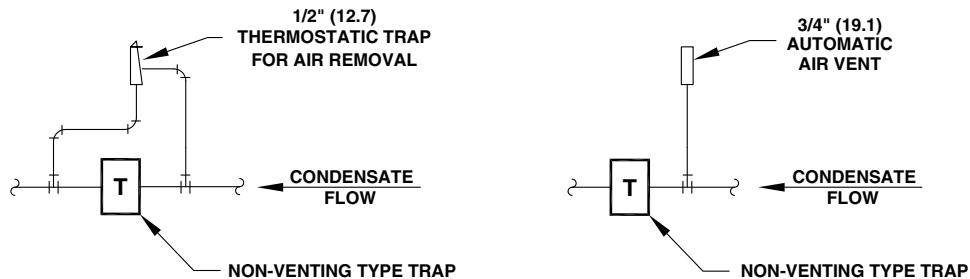

NOTES :

- STANDARD IFB COIL STEAM INLET AND CONDENSATE LINE SIZE IS 3" (76.2) NPT.
- STEAM MAIN NEEDS TO BE SIZED TO HANDLE STEAM FLOW RATE FOR THE TWO COIL SECTIONS TO BE PIPED IN PARALLEL.
- CONDENSATE LINE NEEDS TO BE SIZED TO HANDLE CONDENSATE FLOW RATE FOR THE TWO COIL SECTIONS TO BE PIPED IN PARALLEL.
- DIMENSIONS ARE IN INCHES. DIMENSIONS IN PARENTHESIS ARE IN MILLIMETERS.

PIPING DIAGRAM

Four Row Steam Coils – 15 psig and above – Size 18-60 W15

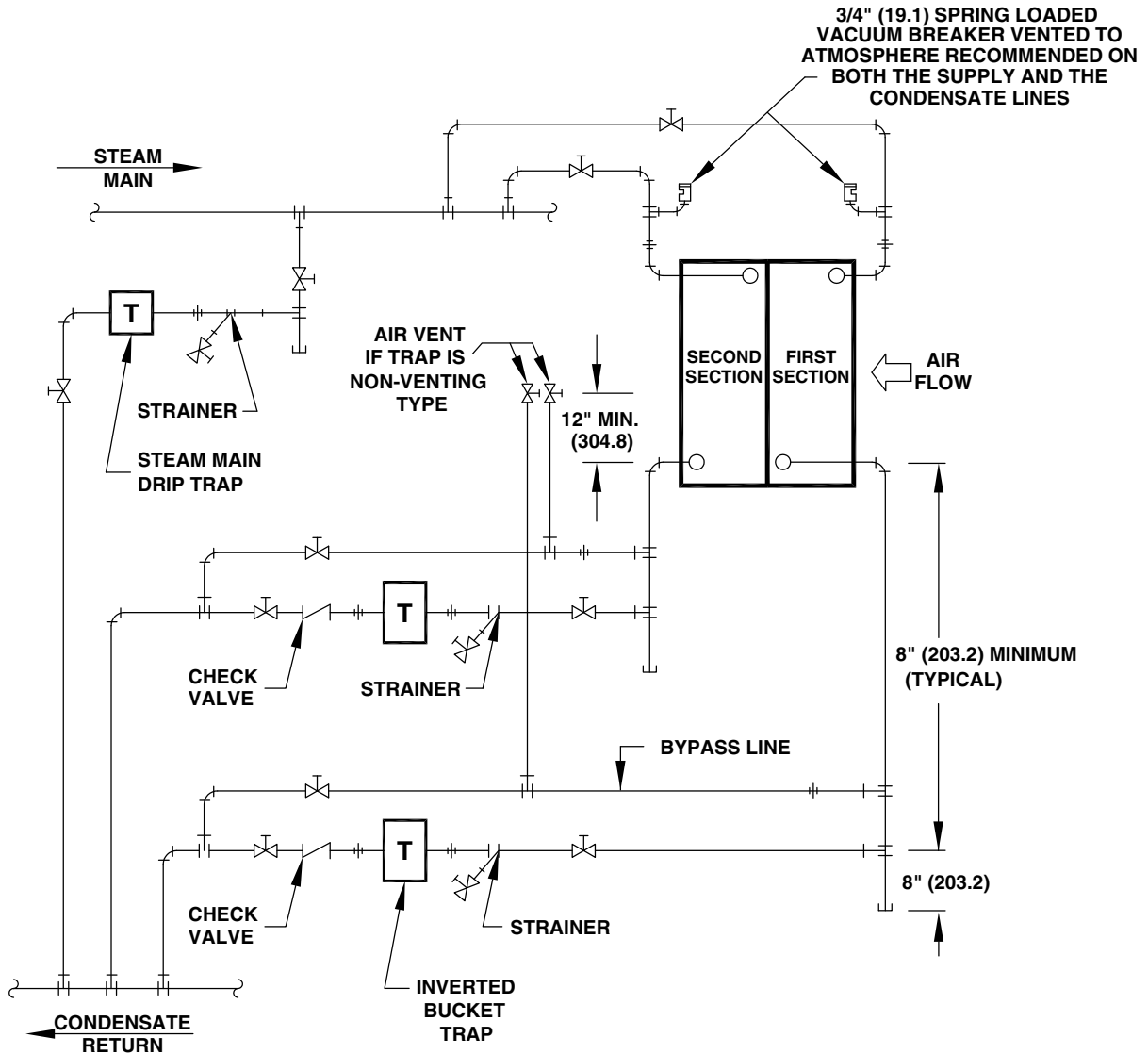

NOTES :

- A. STANDARD IFB COIL STEAM INLET AND CONDENSATE LINE SIZE IS 3" (76.2) NPT.
- B. STEAM MAIN NEEDS TO BE SIZED TO HANDLE STEAM FLOW RATE FOR THE TWO COIL SECTIONS TO BE PIPED IN PARALLEL.
- C. CONDENSATE LINE NEEDS TO BE SIZED TO HANDLE CONDENSATE FLOW RATE FOR THE TWO COIL SECTIONS TO BE PIPED IN PARALLEL.
- D. DIMENSIONS ARE IN INCHES. DIMENSIONS IN PARENTHESIS ARE IN MILLIMETERS.

PIPING DIAGRAM

Four Row Steam Coils – Below 15 psig – Size 66-120

W18

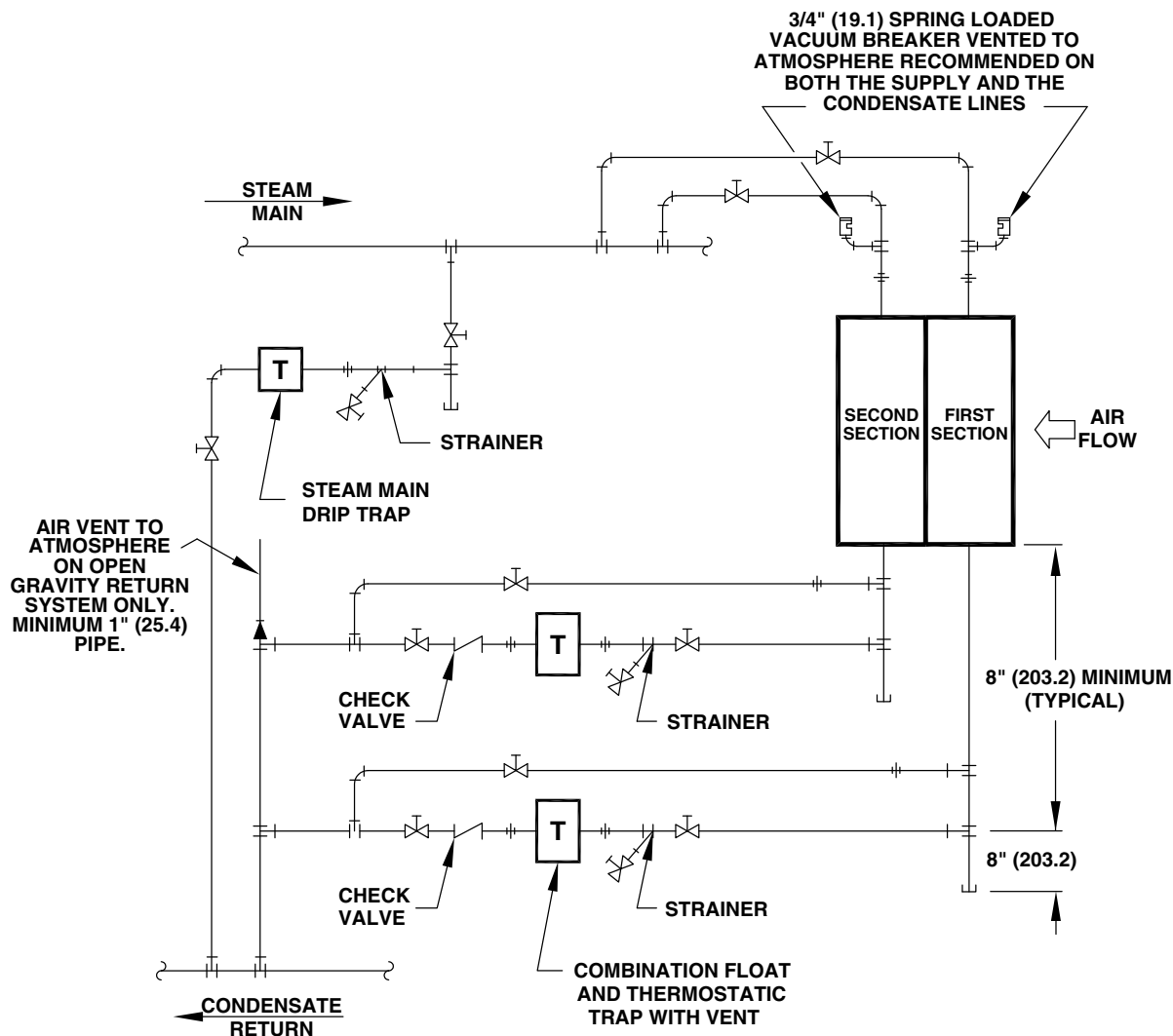

Additional Piping Required For Non-Venting Type Steam Traps

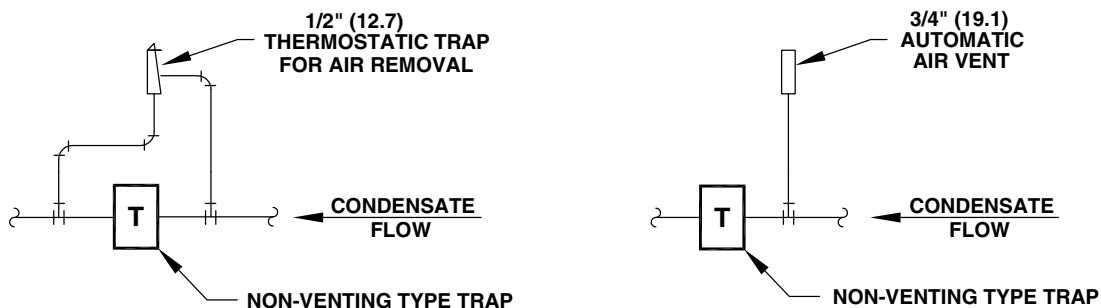

NOTES :

- A. STANDARD IFB COIL STEAM INLET AND CONDENSATE LINE SIZE IS 3" (76.2) NPT.
- B. STEAM MAIN NEEDS TO BE SIZED TO HANDLE STEAM FLOW RATE FOR THE TWO COIL SECTIONS TO BE PIPED IN PARALLEL.
- C. CONDENSATE LINE NEEDS TO BE SIZED TO HANDLE CONDENSATE FLOW RATE FOR THE TWO COIL SECTIONS TO BE PIPED IN PARALLEL.
- D. DIMENSIONS ARE IN INCHES. DIMENSIONS IN PARENTHESIS ARE IN MILLIMETERS.

PIPING DIAGRAM

Four Row Steam Coils – 15 psig and above – Size 66-120 W19

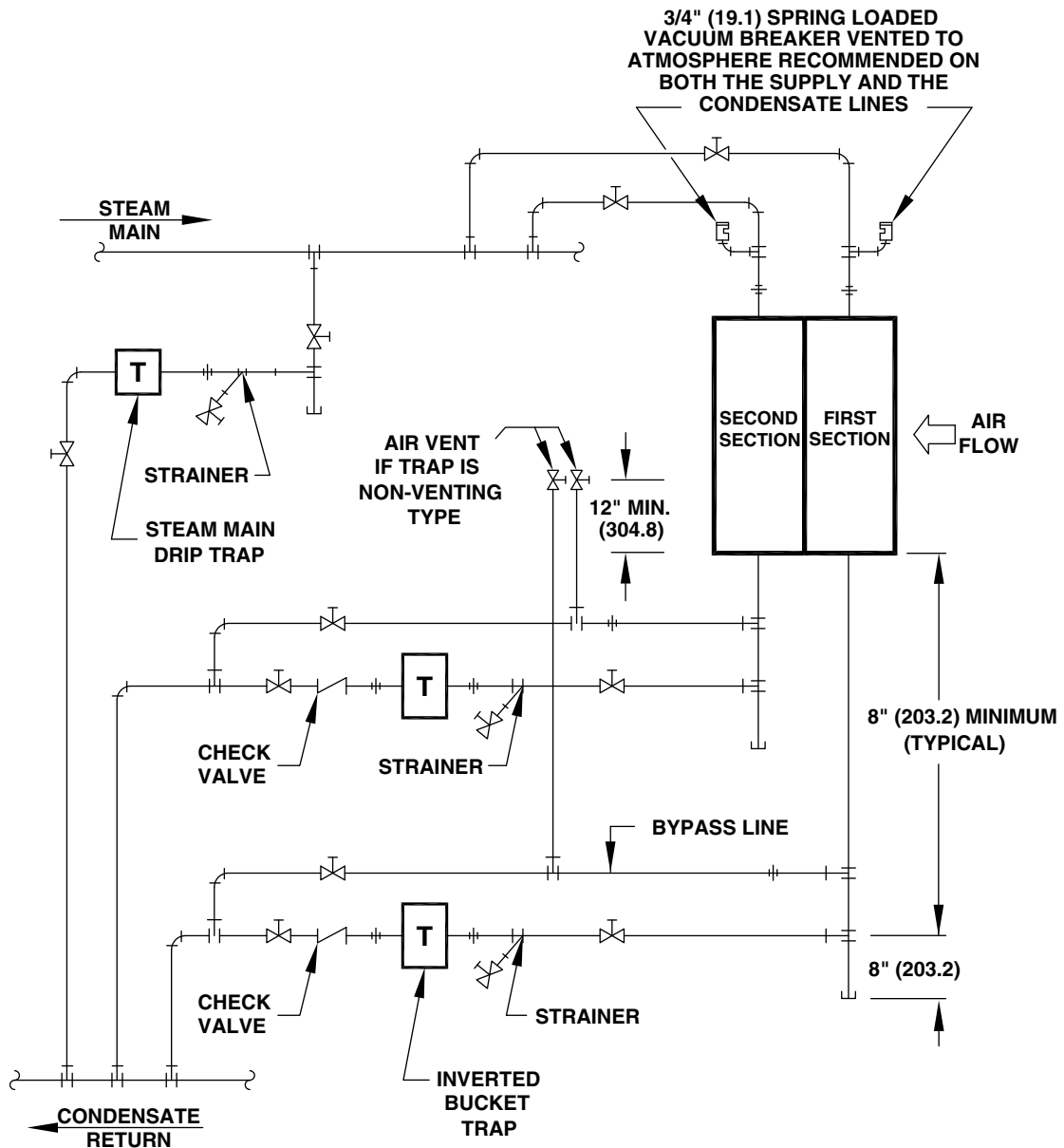

NOTES :

- A. STANDARD IFB COIL STEAM INLET AND CONDENSATE LINE SIZE IS 3" (76.2) NPT.
- B. STEAM MAIN NEEDS TO BE SIZED TO HANDLE STEAM FLOW RATE FOR THE TWO COIL SECTIONS TO BE PIPED IN PARALLEL.
- C. CONDENSATE LINE NEEDS TO BE SIZED TO HANDLE CONDENSATE FLOW RATE FOR THE TWO COIL SECTIONS TO BE PIPED IN PARALLEL.
- D. DIMENSIONS ARE IN INCHES. DIMENSIONS IN PARENTHESIS ARE IN MILLIMETERS.

PIPING DIAGRAM

Two, Three and Four Row Hot Water Coils – Size 18-60

W17

SINGLE SECTION - 2 AND 3 ROW COILS

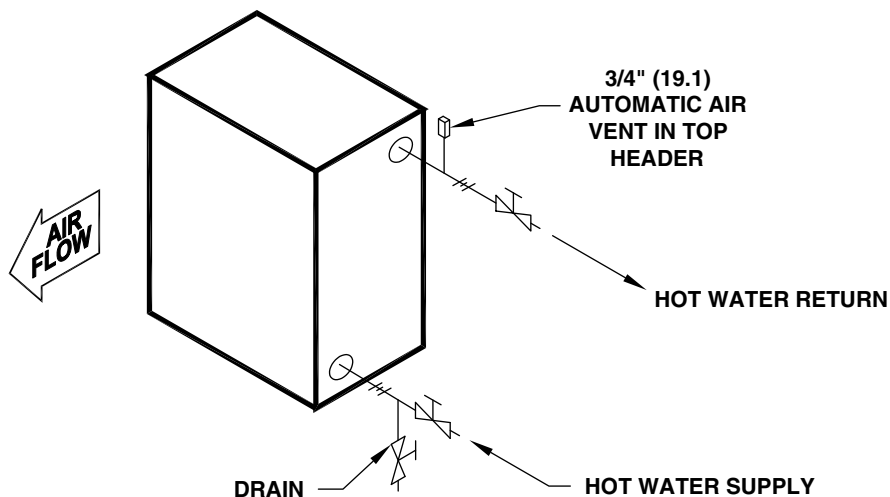

DOUBLE SECTION - 4 ROW COIL

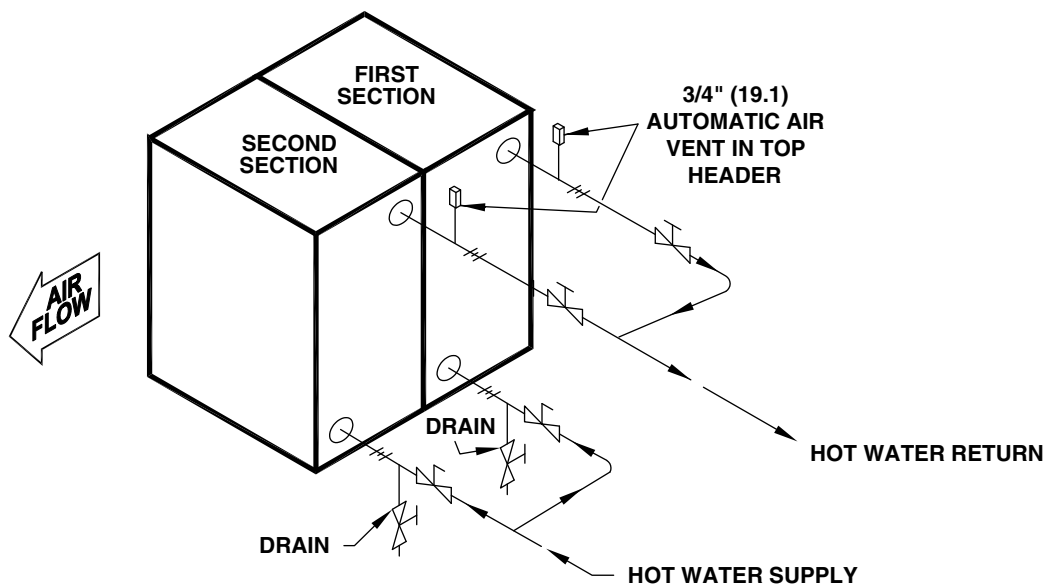

NOTE : DIMENSIONS ARE IN INCHES.
DIMENSIONS IN PARENTHESIS ARE IN MILLIMETERS.

PIPING DIAGRAM

Two, Three and Four Row Hot Water Coils – Size 66-120 W11

SINGLE SECTION - 2 AND 3 ROW COILS

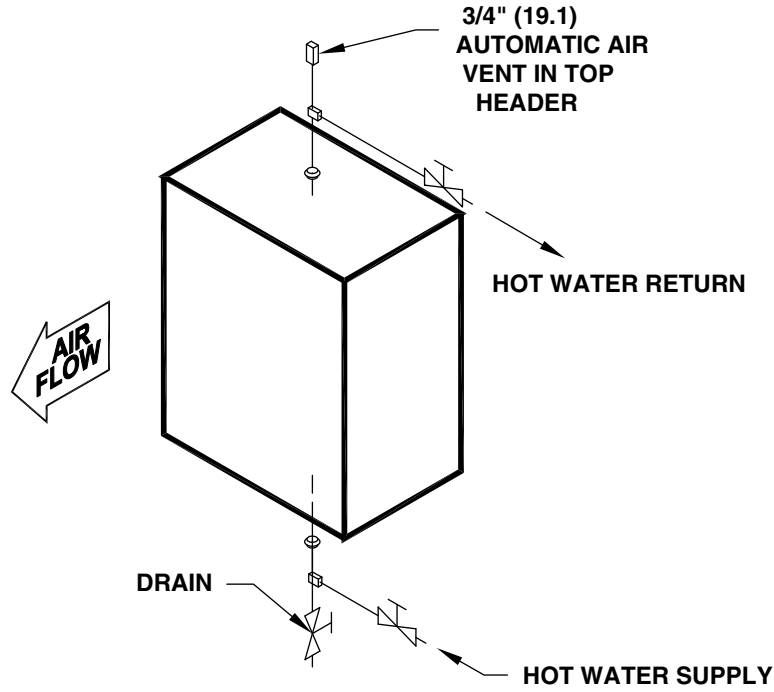

DOUBLE SECTION - 4 ROW COIL

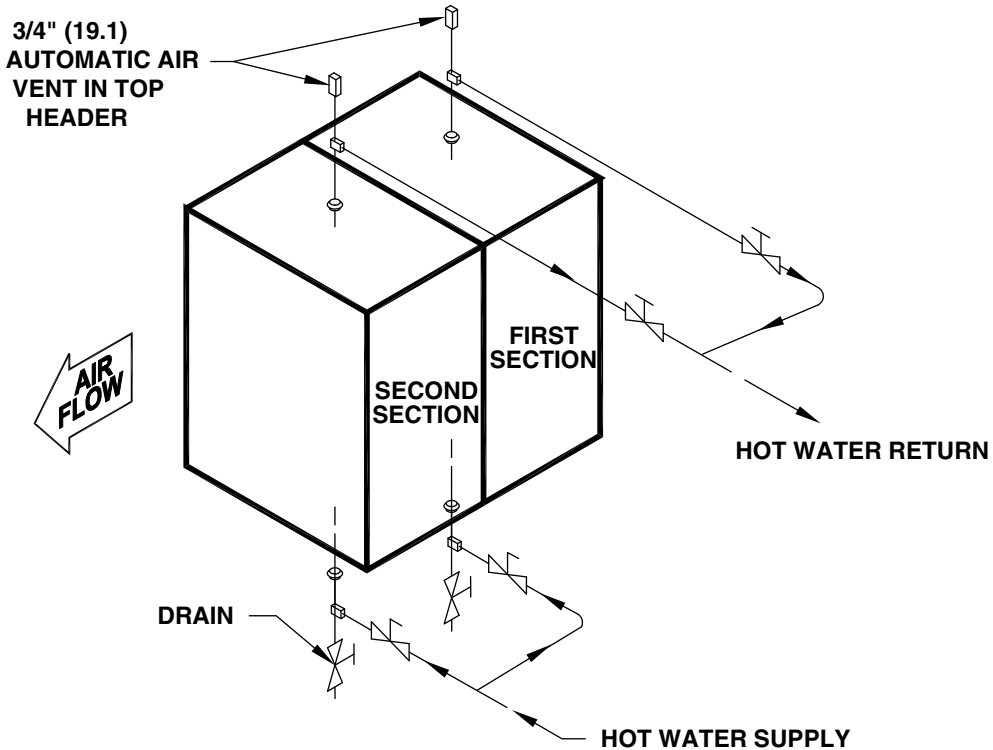

NOTE : DIMENSIONS ARE IN INCHES.
DIMENSIONS IN PARENTHESIS ARE IN MILLIMETERS.

CONTROLS

Electric and Pneumatic

Wing's IFB coil meets the most exacting requirements of accurate temperature control. Air stream temperature is controlled by an air stream thermostat that operates in conjunction with an electric or pneumatic actuator to properly position the dampers to achieve the proper balance of face and bypass airflows.

Damper actuators furnished by L.J. Wing are factory-mounted to ensure precise adjustment and to provide a complete package that is ready for installation and operation.

Damper actuators are side-mounted as standard on the left hand side of the unit casing (when looking in the direction of air flow). Right hand damper actuator mounting is optional.

On electric control installations, electric proportional damper motors are used which, if a control failure occurs, will remain at the last controlling position.

On pneumatic control installations, the actuators close the bypass dampers on spring return stroke to protect the system in event of control air pressure failure. (Pilot positioners are required).

Electric actuators may be of the direct-coupled or indirect-coupled type.

Integral face and bypass coils are subject to some temperature override, i.e., a rise in air stream temperature above the desired set point in the full bypass mode. Coil temperature override occurs as a result of heat picked up from the hot damper blades. In the event that any temperature override is undesirable a slow-acting two-position (i.e., fully open or fully closed) valve should be installed.

All motorized shut-off or pressure reducing valves should be of the normally-open type, so that in the event of a malfunction, they will fail in the open position

The air stream or low limit thermostat bulb should be located in the air stream a minimum of three feet downstream (two feet if anti-stratification baffles are installed) of the coil. The thermostat bulb should be positioned parallel to the headers across both the face and bypass sections. When coils are installed in banks, each coil should have its own thermostat for positive temperature control.

**Typical Electric Control
(0 - 135 OHM)**

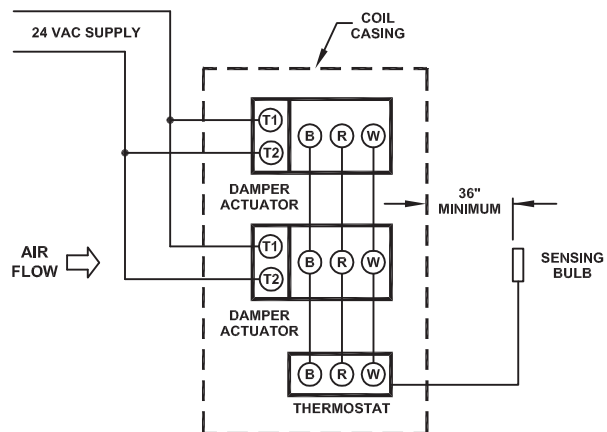

Typical Pneumatic Control

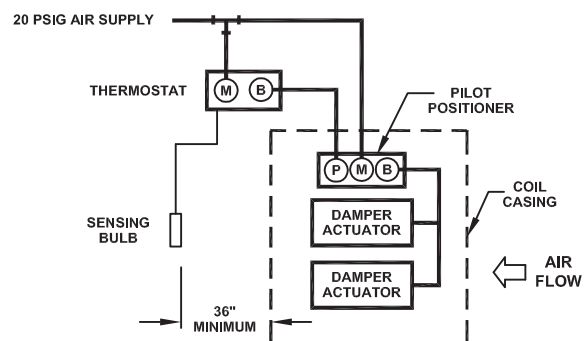

INSTALLATION TIPS

Control Valves

Full steam pressure or water flow must be supplied at all times – modulating valves must not be used. A modulating steam valve on a preheat coil can actually cause the coil to retain the condensate due to a reduced pressure in the coil, thus exposing condensate in the tubes to freezing conditions.

To isolate the coils in the off-season, slow acting on/off valves may be used. If motorized steam valves are employed, they should be of the normally open type so if the actuator fails, the valve will go to the open position.

Temperature Override

The amount that the delivered air temperature exceeds the thermostat setting is called temperature override. To minimize temperature override:

- (a) Use slow –acting on/off valves to close at desired set points.
- (b) Insulate inlet and outlet mains located in the airstream.
- (c) Insulate internal steam manifolds and piping of humidifiers installed within the air handler.

Temperature Controls

The airstream thermostat control to the coils should be located a minimum of 36” downstream. Each coil should have its own temperature control system.

Freezestats mounted on the face of the cooling coils should be located a minimum of 36” downstream of the IFB coil flange. Optional anti-stratification baffles are available to reduce this spacing to 24”.

Coils operating at lower or higher than recommended air velocities or in VAV systems should be fitted with optional anti-stratification baffles.

Piping and Start-Up

Steam pipes must be sized to handle desired steam flows at the lowest pressures.

Where more than one (1) coil is used, each coil should be piped independently.

To avoid freezing of pre-heat coils when applying steam or hot water in very cold locations, first raise the tube metal temperature above freezing by applying steam or hot water to the coil prior to passing airflow over it.

ACCESSORIES

Steel Tubes

Available for applications where the job requirements preclude the use of copper or 90/10 cupronickel tube materials.

90/10 Cupronickel Tubes

Available for applications with higher steam pressures up to 350 psig.

0.049" Wall Copper Tubes

Available for applications with higher steam pressures.

Copper Headers

For systems requiring extra cleanliness in the boiler return water.

Anti-Stratification Baffles

For applications where the heated and bypass air must be mixed within a reduced area. Allows reduction of the downstream mixing length from 36" to 24".

Casing Flange Extensions

For applications where it is desirable to match coil casing to a fixed duct or an air handling unit in the field.

Raised Face Flanges on Header Connections

For applications where coil piping must match existing field piping. Both threaded and welded designs are available.

Crossover Piping

Connects both sections of a four row coil so that only one input and one output connection is required instead of two connections each. Available for hot water applications only; reduces GPM by half with some reduction in performance.

Painted Finish

Unit casing and dampers can be fabricated of galvanized steel painted inside and out with an air-dried alkyd enamel finish.

Epoxy Coating

Entire coil can be provided with a durable epoxy coating for applications in corrosive atmospheres.

Stainless Steel Construction

Casing, damper blades, and most of linkage can be furnished in type 304 stainless steel for applications in corrosive atmospheres.

Electric Freezestat

Shuts off fan if freezing temperatures are sensed. Provided factory-mounted on the downstream face of one tube bank.

Electric Fan Cut-Off Thermostat

Mounts on fan inlet to shut off fan if supply air temperature is too cold.

Pressuretrol®

Safety device for steam applications only. Shuts off power to system if inlet steam pressure drops below set point. Shipped loose for field mounting on steam main.

Aquastat®

Safety device for hot water applications only. Shuts off power to system if inlet water temperature drops below set point. Shipped loose for mounting on inlet water main.

Weatherproof Housing

For outdoor installations to protect the linkage controls. Housing includes a removable panel for easy access.

SPECIFICATIONS AND SCHEDULE

Typical Specification

General

Furnish type IFB integral face and bypass coils as manufactured by L.J. Wing, Dallas, TX, to heat air using steam or hot water as the heating medium. Performance shall be ARI-certified and as shown in the schedule. Each heating coil shall consist of built-in series of finned heating elements and bypasses with interlocked dampers controlled by optional electric (or pneumatic) damper motor(s) and air stream thermostat. Dampers are to be arranged so as to completely enclose and isolate the heating coil passes when no temperature rise is required. Each coil shall be capable of maintaining a constant discharge air temperature regardless of variations in entering air temperatures with full steam pressure or water flow at all times. Actuators are to be side-mounted.

Proportioning of the air shall be such that the temperature at any point in a plane parallel to the face of the coil three feet (**two feet if optional anti-stratification baffles are installed**) downstream from the leaving air side will not vary more than +/- 5° F from the average discharge air stream temperature.

Finned heating elements shall be fabricated of seamless return bend type 5/8" o.d. copper (**optional: 90/10 cupronickel, steel**) tubes of 0.035" (**optional: 0.049"**) wall thickness with rectangular fins of 0.010" thick aluminum. Fins shall not be spaced closer than 12 fins per inch. Each tube shall be secured to the headers by a brazed joint. Finned elements shall be factory tested with 500 psig hydrostatic pressure.

Unit casing and dampers shall be fabricated of heavy gauge galvanized steel (**optional: type 304 stainless steel**). Headers shall be three-inch diameter, SCH 40 steel (**optional: copper**) pipe.

Options:

Painted Finish – Unit casing and dampers shall be fabricated of galvanized steel painted inside and out with an air-dried alkyd enamel finish.

Casing Flange Extensions – Coil casing shall be furnished with extended flanges to match a fixed duct connection.

Epoxy Coating – Coil shall be furnished with a baked epoxy coating for corrosion protection.

Raised Face Flanges on Header Connections – Raised face flanges shall be supplied on the header connections.

Weatherproof Housing – A weatherproof housing shall be furnished over the actuators to protect them from the outdoor elements.

Electric freezestat – Provide factory-mounted electric freezestat on the downstream face of one tube bank of the coil.

Electric Fan Cut-Off Thermostat – Furnish electric fan cut-off thermostat to shut off fan if supply air temperature is too cold. Thermostat is to be shipped loose for field mounting by others.

Typical Schedule

Model no.	Airflow Rate (scfm)	Ent. Air Temp. (degrees F)	Leav. Air Temp. (degrees F)	Steam Pressure (psig)	Condensate load (lbm/hr)	Air Pressure Drop (inches w.c.)
C-54	7,000	-10	55	15	635.4	0.36