

LJ WING[®]

INSTALLATION, OPERATION AND MAINTENANCE MANUAL

IFB HEATING COILS

ATTENTION: READ THIS MANUAL AND ALL LABELS ATTACHED TO THE UNIT CAREFULLY BEFORE ATTEMPTING TO INSTALL, OPERATE OR SERVICE THESE UNITS! CHECK UNIT DATA PLATE FOR STEAM OR HOT WATER REQUIREMENTS AND ELECTRICAL SPECIFICATIONS AND MAKE CERTAIN THAT THESE AGREE WITH THOSE AT POINT OF INSTALLATION. RECORD THE UNIT MODEL AND SERIAL No.(s) IN THE SPACE PROVIDED. RETAIN FOR FUTURE REFERENCE.

WING Model No. _____ Serial No. _____

SAVE THIS MANUAL



SINCE 1896

WARNING: Improper installation, adjustment, alteration, service or maintenance can cause property damage, injury or death. Read the installation, operating and maintenance instructions thoroughly before installing or servicing this equipment.

INSTALLER'S RESPONSIBILITY

Installer Please Note: This equipment has been tested and inspected. It has been shipped free from defects from our factory. However, during shipment and installation, problems such as loose wires, leaks or loose fasteners may occur. **It is the installer's responsibility to inspect and correct any problems that may be found.**

ATTENTION: READ CAREFULLY BEFORE ATTEMPTING TO INSTALL, OPERATE OR SERVICE THIS EQUIPMENT. RETAIN FOR FUTURE REFERENCE.

POST AND MAINTAIN THESE INSTRUCTIONS IN LEGIBLE CONDITION.



4830 Transport Drive, Dallas, TX 75247
Tel: (214) 638-6010 • Fax: (214) 905-0806
www.ljwing.com



SECTION I - FORWARD

As is the case with any fine piece of equipment, care must be taken to provide the proper attention to the operation and maintenance details of this machine.

This manual of instructions has been prepared to help you become well-acquainted with those details, and in doing so, you will be able to give your Wing IFB Heating Coil the care and attention any piece of equipment needs and deserves.

Table of Contents

Section I: Forward and Table of Contents	2
Section II: General Information.....	2
Section III: Installation and Mounting.....	3
Section IV: Ductwork and Transitions.....	5
Section V: Parts Drawing.....	6-7
Section VI: Piping	8-16
Section VII: Control Installation and Adjustment	17
Section VIII: Start Up	18
Section IX: Shut Down.....	18
Section X: Maintenance.....	19
Section XI: Tube Removal and Replacement.....	19

SECTION II - GENERAL INFORMATION

A. Purpose

The purpose of this manual is to present a guide for proper installation, maintenance, and operation of the Wing IFB Heating Coil, and supplement, BUT NOT TO REPLACE, the services of qualified field service personnel to supervise the initial start-up and adjustment of the unit. Persons without previous experience with large commercial and industrial heating equipment should not attempt the initial adjustment and checkout procedure which is essential before such installations may be considered ready for operation. This manual should be made readily available to all operating personnel as an aid in troubleshooting and proper maintenance.

B. Shipping

Basic Wing coils are shipped completely assembled. Other large options or accessories are assembled and shipped mounted and wired whenever possible within limitations of shipping and handling. Any optional accessories shipped separately are shipped as assembled sections. Any wired accessories which have been disassembled for separate shipment require no additional conduit or wire for field reassembly. All wire leads will be tagged for ease of reconnection in the field.

Shipments are made F.O.B. Dallas, Texas by flatbed truck. The unit is securely strapped, tied, and blocked to prevent shipping damage. All shipments are checked by an inspector before they are accepted by the carrier. Parts that are shipped unmounted are noted on the bill of lading. These parts, where feasible, are packaged and shipped with the units. Upon receipt of shipment, all units should be checked against the bill of lading to insure all items have been received. All equipment (and any optional accessories) should be checked carefully for physical damage in the presence of the carrier's representative. If parts are missing or damage has occurred, a claim should be filed immediately with the carrier.

C. Receiving

All coils are crated at the factory for safe shipment. Check the unit carefully, and if damage has occurred, report it at once to the carrier. All claims must be made within 5 days of receipt of shipment. Upon receiving, inspect the following for damage:

1. Damper linkage
2. Damper motors and control linkage
3. Finned tubes and dampers
4. Casing, for distortion
5. Header pipe connections
6. Duct attachment flanges

Check the unit nameplate to insure size is correct as ordered.

If system tags have been used, check that proper size units have been tagged for correct system. (Wing will tag units for specific systems upon request.)

All Wing coils are given a complete operations test and control circuit checkout before shipment. A copy of the wiring diagram and bill of material is included with each unit shipped. If correspondence with the factory is necessary, please provide the unit model and serial number.

D. Lifting and Handling

Four (4) 11/16" diameter holes on side header coils or two (2) 13/16" diameter holes on center header coils are provided for lifting with overhead cranes. If a single chain lift is used, a "Tee" section spreader bar must be used to produce a vertical lift to prevent bending of casing flanges. **DO NOT WRAP CHAIN OR CABLE AROUND UPPER HEADER TO LIFT UNIT.**

All Wing IFB coils are shipped bolted onto a wood skid so they can be handled by fork lift. Forks can be inserted under the wood skid for lifting and on site handling.

Wing IFB Heating Coils are supplied with connecting flanges on upstream and downstream sides of the coil. Do not use flanges for lifting or supporting coil. When lifting or supporting the IFB coil for installation, connect rigging hooks or eye bolts to units as shown in Figure 1.

Do not attempt to lift or support coil for installation by attaching rigging to dampers, tubes, flanges or interior sheet metal.

CAUTION: COIL MAY BE UNSTABLE ON FORKS AND SHOULD BE SECURED FROM TIPPING BY ATTACHING CABLES OR CHAINS FROM TOP OF UNIT TO VERTICAL TRACKS OF FORK LIFT.

E. Optional Factory Service

Periodic service on any piece of mechanical equipment is necessary for efficient operation. L.J. Wing has a nationwide service organization available to provide quick and dependable servicing of heating coils. Wing also offers factory start-up service which includes the presence of a service engineer to supervise the initial start-up and adjustment of the equipment and provide instructions for the owner's maintenance personnel in proper operations and maintenance. Consult factory for quotations on periodic or start-up service.

Figure 1 - Coil Lifting and Mounting Drawings

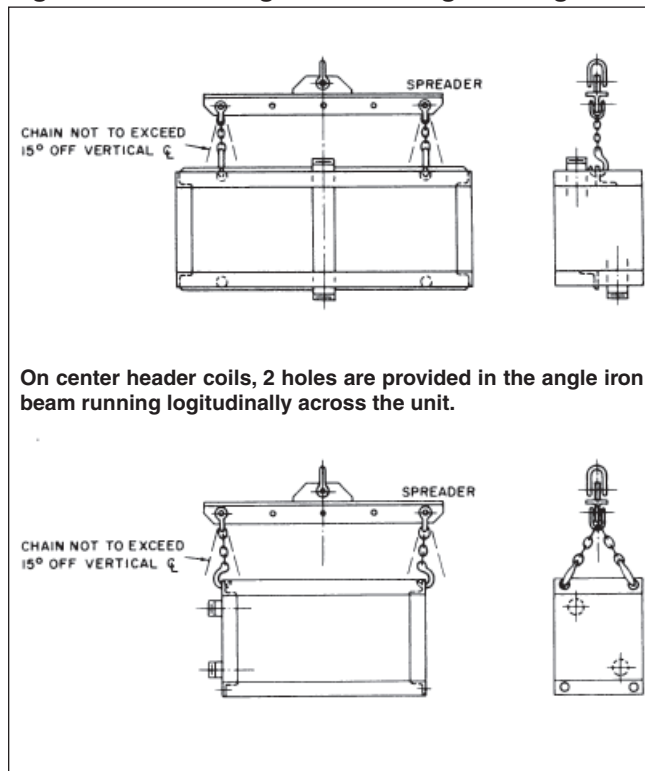

SECTION III - INSTALLATION AND MOUNTING

A. On steam installations the coil should not be pitched to allow for condensate draining. This is already built into the coil. For horizontal airflow, the bottom flange of the coil must be level. Use a spirit level to check. Center support may be required on center header coils. Steam supply header must be higher than the return for proper drainage.

B. At least 18" clearance should be provided on the damper motor and control linkage side of the coil for service access.

C. The coils can be supported on the integral mounting flange or on angle iron legs attached to the duct mounting flanges.

D. The IFB coil must be installed with headers level for proper condensate drainage. To insure proper leveling, use a spirit level. **DO NOT LEVEL BY MEASUREMENT ONLY.**

E. Ductwork can be attached to the coil flanges or the coil can stand in a duct with bulkhead plates blanking off spaces around the coil. The flanges must not be used to support the ductwork.

F. Helpful tips to insure successful installation of Wing coils in air handlers:

Coil Installation and Location

1. Sheet metal isolation plates should be installed on the top and bottom of the IFB coil to eliminate air flow over the supply and return headers, and upstream of the coil on both ends to prevent airflow around the coil.
2. Cooling coils should be located downstream at a distance no less than 36 inches from each other, flange to flange, as shown in Figure 2. The IFB coil can be ordered with anti-stratification baffles in the bypass to reduce the spacing to 24". Freezestat location should also follow this same guideline. Coils operating in VAV systems, or those operating at lower or higher than recommended air velocities, should be fitted with anti-stratification baffles.

Figure 2

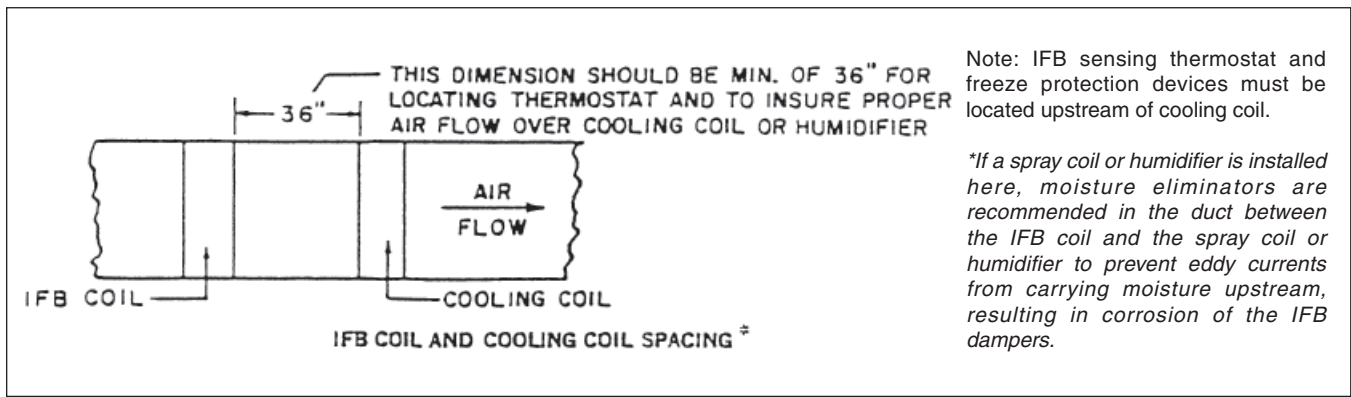

3. The installation of humidifiers with steam manifolds internal of an air handler may provide a temperature override to the system if not fitted with on/off steam valves. Internal steam manifolds should be insulated.

Temperature Control

- a. The air stream thermostat controls to the coils should be located a minimum of 36 inches downstream.
- b. Each coil should have its own air temperature control system.

Steam Coils

- a. For steam installations, coil can be mounted in any orientation shown in Figure 3. STEAM INLET SHOULD BE ON THE UPPER HEADER CONNECTION. STEAM OUTLET SHOULD BE ON THE LOWER HEADER CONNECTION TO ALLOW FOR CONDENSATE DRAINAGE.
- b. Do not pitch IFB coil for condensate draining; this is already built into the coil.
- c. Steam pipes must be sized to handle desired steam flows at the lowest pressures.
- d. Inlet and outlet steam lines should be fully insulated.
- e. Modulating valves **SHOULD NOT** be used on Wing steam coils. Slow-acting on/off steam valves may be used to close at desired set points. If motorized steam valves are employed, they should be of the normally open type so that if the actuator fails, the valve will go to the open position, thereby keeping the steam supply to the coil.
- f. If temperature override is unacceptable, a motorized valve with outdoor sensing bulb is recommended to shut off the steam to the coils when the outdoor temperature reaches the thermostat set point.
- g. Where more than one coil is used, each coil should be piped independently.
- h. A drip leg should be installed at the steam outlet.
- i. Good engineering practices and procedures should be applied in the design of a condensate removal system. In particular, long piping runs to condensate pumps should be avoided.

Figure 3 - Proper Coil Mounting Drawings

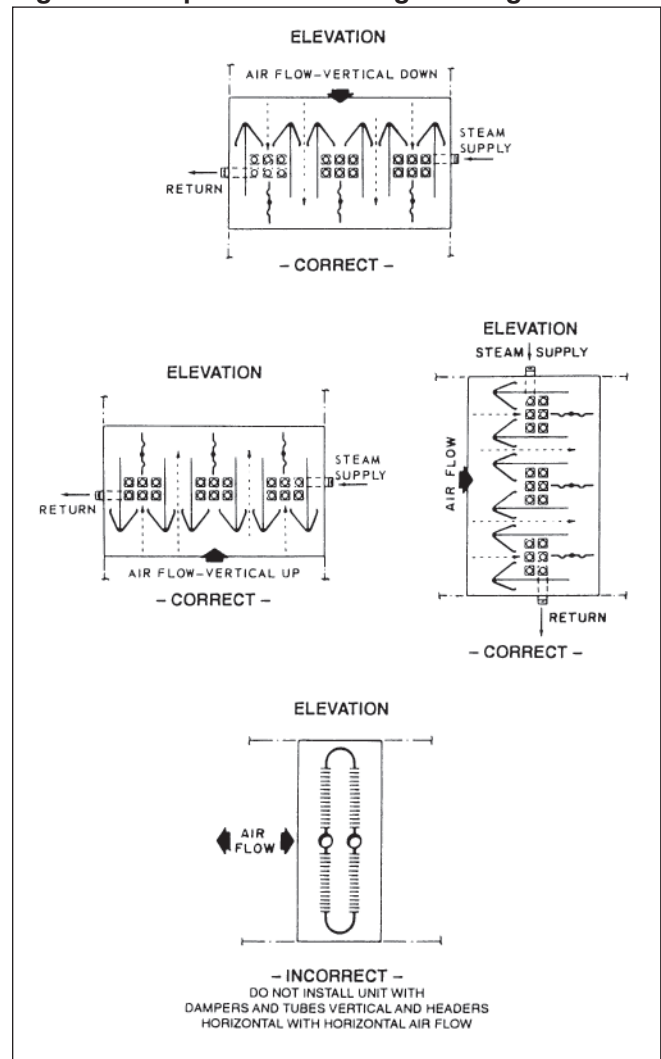

Hot Water Coils

1. On hot water installations, coil can be mounted in any orientation shown in Figure 3. **WATER INLET SHOULD BE ON THE LOWER HEADER CONNECTION.**

WATER OUTLET SHOULD BE ON THE HIGHER HEADER CONNECTION TO PURGE AIR FROM THE COIL.

SECTION IV - DUCTWORK AND TRANSITIONS

A. To obtain rated performance from the coils and to eliminate air temperature control problems due to improper duct design and/or installation, use the following suggestions as a guide in the design of ducts and transitions.

Angle " α " in Figure 4 should not exceed 15 degrees. Steeper angles in duct transitions will create low air velocities in one portion of a coil, and high air velocities in the other portion of the coil, resulting in poor downstream temperature control.

**Figure 4 -
Duct
Transitions
Drawing**

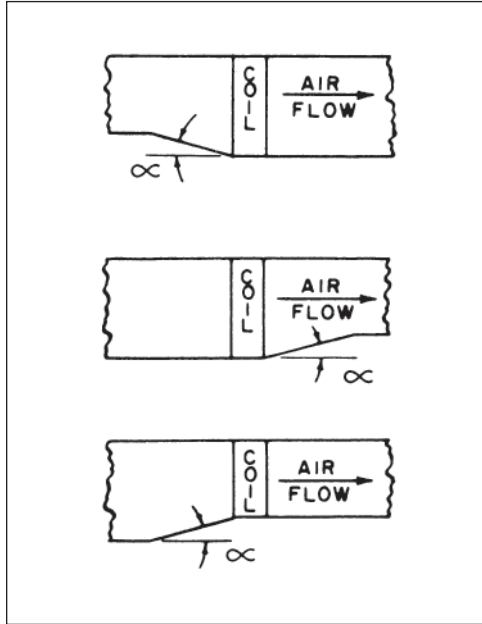

B. Turning vanes must be used to assure even distribution of air over the entire coil where elbows are used in the inlet and/or outlet side of a preheat coil. (See Figure 5.)

Figure 5 - Insert Elbows In Ducts, Top View

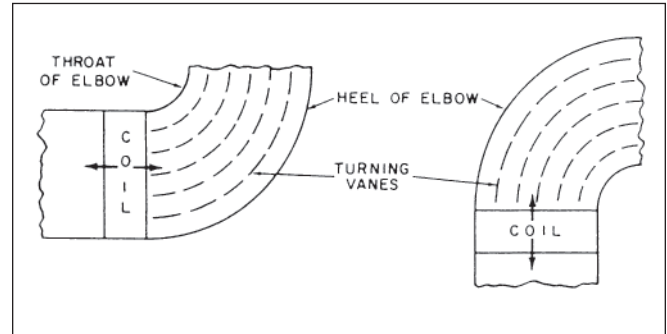

SECTION V - PARTS DRAWING

Figure 6 - IFB Coils 36 thru 60 Side Header

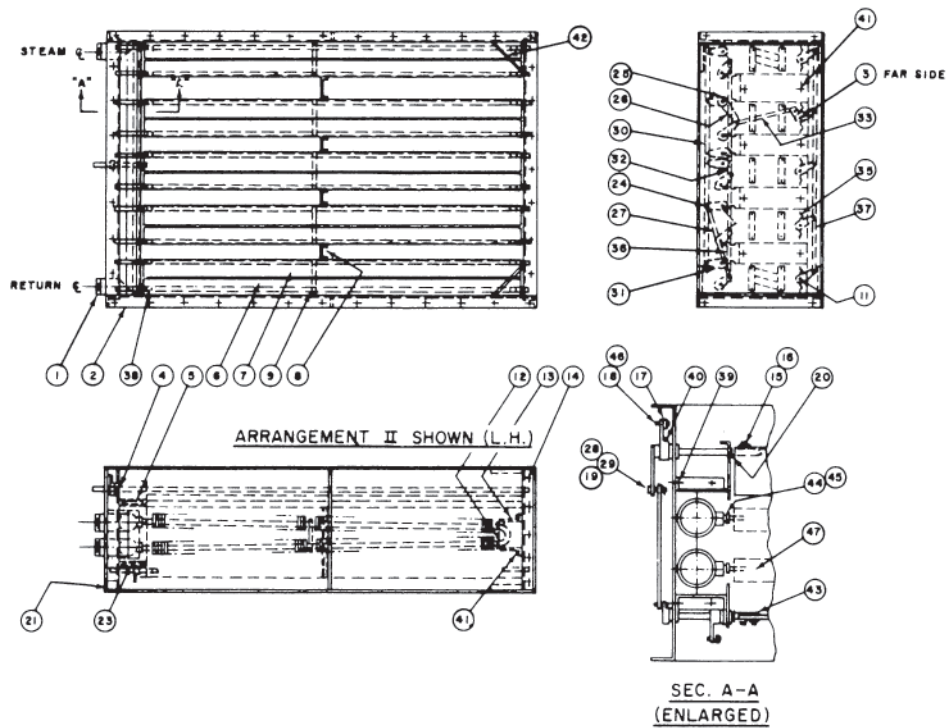

No. Name of Piece

- 1. ELEMENT
- 2. CASING
- 3. DAMPER ROD
- 4. NYLON BEARING
- 5. UPPER CHANNEL
- 6. END DAMPER
- 7. STANDARD DAMPER
- 8. STANDARD BYPASS
- 9. TUBE HANGER
- 10.
- 11. DAMPER ROD
- 12. TUBE SPACER
- 13. TUBE SUPPORT
- 14. 3/8 x 16 x 1 LARGE HEX HEAD

No. Name of Piece

- BOLT NUT & L.W. (CAD. PL)
- 15. DAMPER WASHER
- 16. 1/4-20 x 5/8 HEX HEAD BOLT & 1/2 O.D. x 3/64 THICK
- 17. STEEL WASHER 3/16 I.D. x 1/2 O.D. x 3/64 THICK
- 18. BRASS RIVET
- 19. COTTER PIN
- 20. BRASS WASHER 1/2 I.D. x 1 O.D. x 1/32 THICK
- 21. SUPPORT ANGLE
- 22.
- 23. LOWER CHANNEL
- 24. BRASS RIVET (LONG)
- 25. DAMPER ROD

No. Name of Piece

- 26. DAMPER ARM
- 27. CONNECTING BAR
- 28. SHOULDER SCREW
- 29. 5/16-18 HEX HEAD NUT CAP. PLT.
- 30. CONTROL BAR
- 31. CRANK
- 32. DRIVE SHAFT & STOP ASSEMBLY
- 33. CONNECTING BAR
- 34.
- 35. DISCHARGE DAMPER
- 36. CONTROL BAR
- 37. CONTROL BAR
- 38. DAMPER ROD
- 39. 1/4-20 x 1/2 LARGE HEX HEAD

No. Name of Piece

- BOLT NUT & L.W.
- 40. 5/16-18 x 5/8 S. HD. SET SCREW CUP PT. HDN.
- 39. 1/4-20 x 1/2 LARGE HEX HEAD BOLT NUT & L.W.
- 41. 10 x 1/2 LARGE HEX HEAD S.M. SCREW TYPE A, CAD. PL
- 42. CORNER BRACE 1/4 x 1/2 x 7 LARGE
- 43. DAMPER ROD
- 44. NUTS (BRASS)
- 45. FLARE (BRASS)
- 46. PALNUT FASTENER
- 47. FINNED TUBE

Figure 7 - IFB Coils 66 thru 120 Center Header

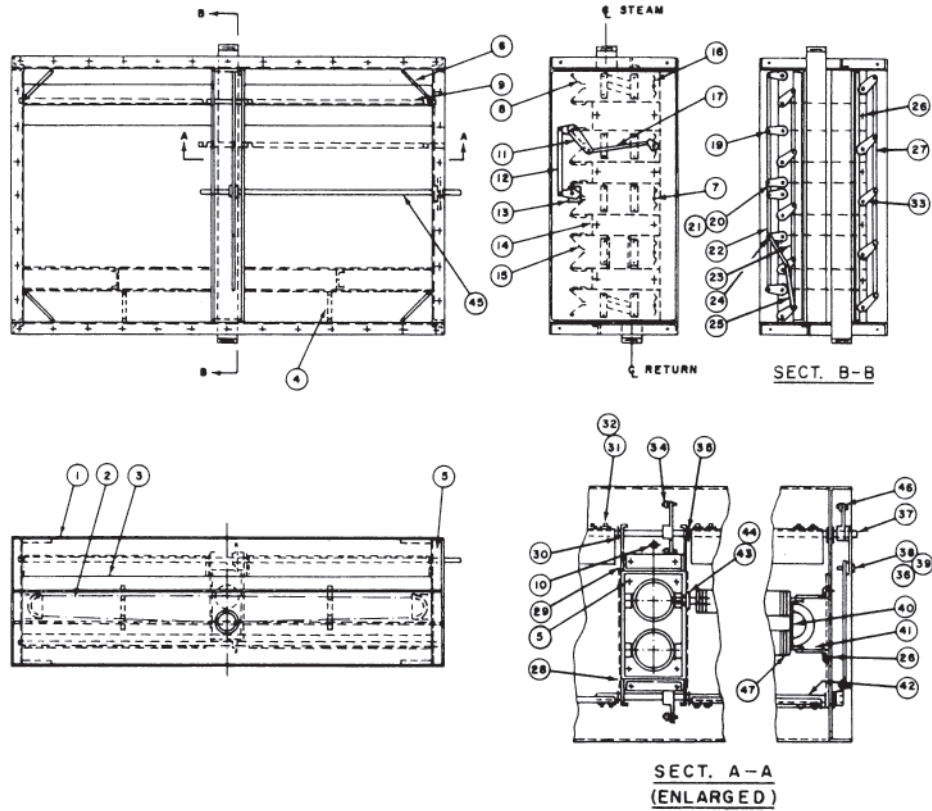

No. Name of Piece

- 1. CASING
- 2. ELEMENT
- 3. ANGLE SUPPORT
- 4. TUBE HANGER
- 5. 3/8-16 x HEX HEAD BOLT NUT & L.W. (CAD. PLT)
- 6. CORNER BRACES 1/4 x 1/2 x 7
- 7. DAMPER ROD
- 8. END DAMPER
- 9. DAMPER ROD
- 10. 1/2" KNOCKOUT PLUG
- 11. DAMPER ARM
- 12. CONNECTING BAR

No. Name of Piece

- 13. DRIVE SHAFT & STOP ASSEMBLY
- 14. BYPASS (STANDARD)
- 15. STANDARD DAMPER
- 16. DISCHARGE DAMPER
- 17. CONNECTING BAR
- 18.
- 19. BRASS RIVET
- 20. CRANK
- 21. 5/16-18 x 5/8 SQUARE HEAD SET SCREW CUP PT. HDN.
- 22. CONTROL BAR
- 23. CONTROL BAR
- 24. BRASS RIVET (LONG)

No. Name of Piece

- 25. CONNECTING BAR
- 26. 10 x 1/2 HEX HEAD S.M.S. TYPE A (CAD. PLT.)
- 27. CONTROL BAR
- 28. LOWER CHANNEL
- 29. UPPER CHANNEL
- 30. BRASS WASHER 1/2 I.D. x 1" O.D. x 1/32 THICK
- 31. DAMPER WASHER
- 32. 1/4-20 x 5/8 HEX HEAD BOLT & L.W. CAD. PLT.
- 33. DAMPER ROD
- 34. STEEL WASHER 3/16 I.D. x 1/2 O.D. x 3/64 THICK

No. Name of Piece

- 35. NYLON BEARING
- 36. COTTER PIN 1/16 DIA. x 1/2
- 37. DAMPER ROD
- 38. SHOULDER SCREW
- 39. 5/16-18 HEX NUT (CAD. PLT.)
- 40. TUBE SPACER
- 41. TUBE SPACER
- 42. DAMPER ROD
- 43. NUTS BRASS
- 44. FLARE BRASS
- 45. PIPE EXTRA HEAVY (SERIES 80)
- 46. PALNUT FASTENER
- 47. FINNED TUBE

SECTION VI - PIPING

- A. A steam supply system which will keep the IFB coil full of steam, and a condensate drainage system which will immediately remove condensate from the IFB coil are essential to obtain reliable performance and full rated heating capacity from the coil.
- B. The following piping recommendations and diagrams will result in an installation which will be reliable and trouble-free:
1. Tube Expansion - The IFB design incorporates space to provide for the expansion of the finned tubes when steam or hot water is applied to the coil.
 2. Steam mains, return mains, and traps must be anchored and supported independently of the Wing IFB. Steam piping should incorporate expansion joints to isolate piping expansion strains from the unit.
 3. A drip trap should be installed between the pressure side of the heating section supply valve and the return line. This will prevent steam line condensate from entering the unit with the steam. **DO NOT DRIP STEAM MAINS INTO COIL OR INTO LINE BETWEEN COIL AND TRAP.**
 4. Steam traps should be sized for 3 times the calculated condensate loading at the coil design conditions, based on the pressure differential across the trap, **NOT THE BOILER PRESSURE.** Traps should be of types which pass condensate and air at saturated steam temperature. Inverted bucket traps should incorporate thermostatic air vents.
 5. The steam trap should have provision for air venting. If the trap is non-venting, proper air vents should be provided for each coil to eliminate non-condensable gases. All air vent lines should be a minimum of 1" and properly pitched to assure free venting of air. The venting device should be located at least 12" above the bottom casing of the coil.
In high pressure steam systems (above 15 psig), where a non-venting trap is used for condensate removal, an automatic air vent should be installed in a 1" air line before the condensate trap. Do not return vented air to the condensate return main.
 6. **MAKE RETURN CONNECTION FULL SIZE OF COIL HEADER AND REDUCE AT TRAP. DO NOT USE REDUCING BUSHING ON COIL RETURN CONNECTION.** If shutoff valve, strainer and trap are piped together with pipe nipples, pipe can be reduced to the trap inlet size at the shutoff valve.
 7. Strainers should be installed ahead of traps to prevent dirt and sludge from affecting trap operation. If a strainer is installed in the steam supply line, a strainer ahead of the trap is not required.
 8. **DO NOT** install risers in condensate return lines.
 9. Each coil in a coil bank must be individually trapped and vented.
 10. Install a valved by-pass line around the trap to allow for operation of the coil during trap maintenance, and for use in start-up of the coil in below freezing conditions. (See start-up procedure on page 18.)
 11. If condensate must be lifted above coil discharge into overhead mains, or if return mains are pressurized, a receiver and condensate pump should be installed between condensate traps and return mains.
 12. Use only bucket, or float and thermostatic traps for condensate removal. Use thermostatic traps for venting only.
 13. Proper vacuum breakers should be provided as shown in piping diagrams.
 14. Check valves should be used to prevent condensate backup in case of steam failure.

Figure 8 - IFB Hot Water Piping for Side Header Coils

SINGLE SECTION - 2 AND 3 ROW COILS

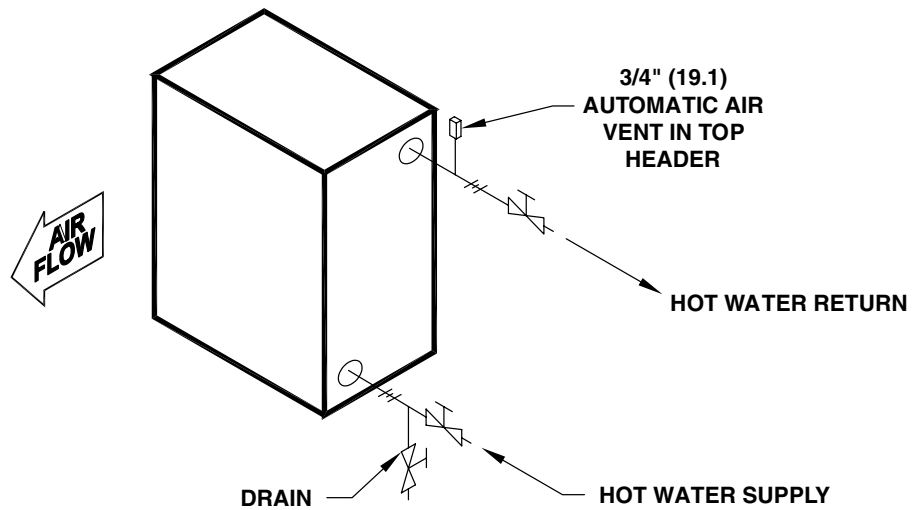

DOUBLE SECTION - 4 ROW COIL

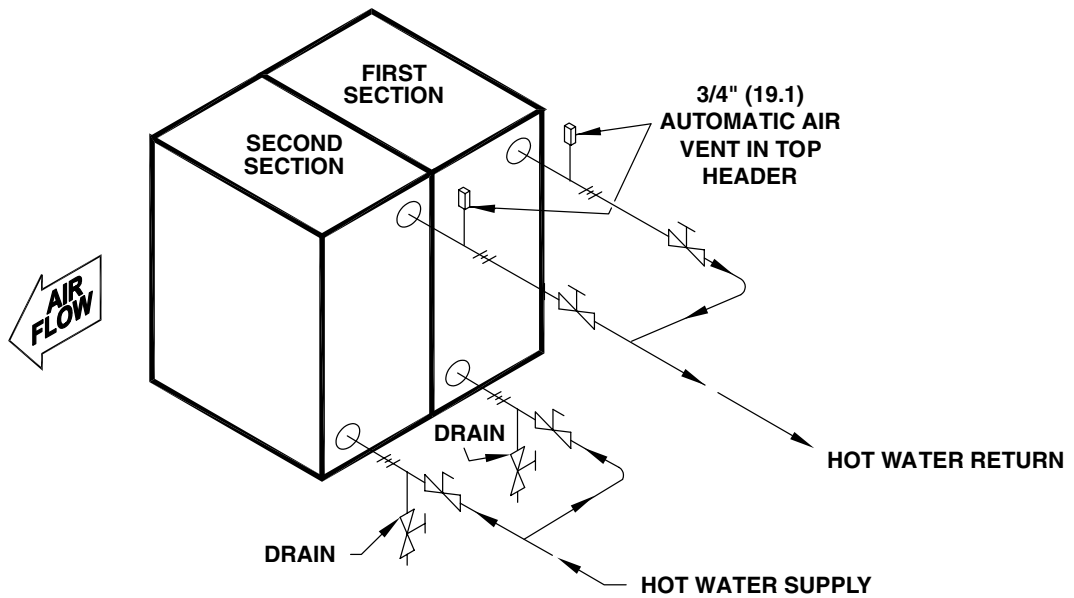

NOTE : DIMENSIONS ARE IN INCHES.
DIMENSIONS IN PARENTHESIS ARE IN MILLIMETERS.

Figure 9 - IFB Hot Water Piping for Center Header Coils

SINGLE SECTION - 2 AND 3 ROW COILS

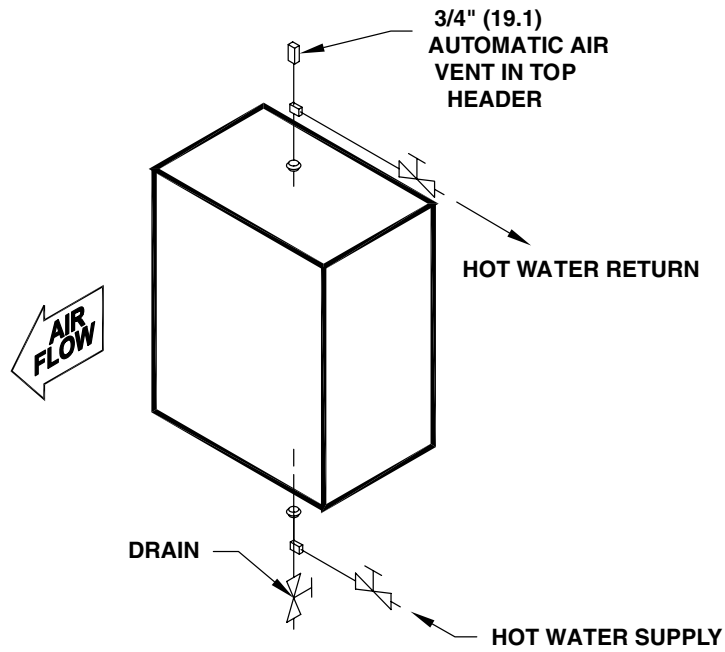

DOUBLE SECTION - 4 ROW COIL

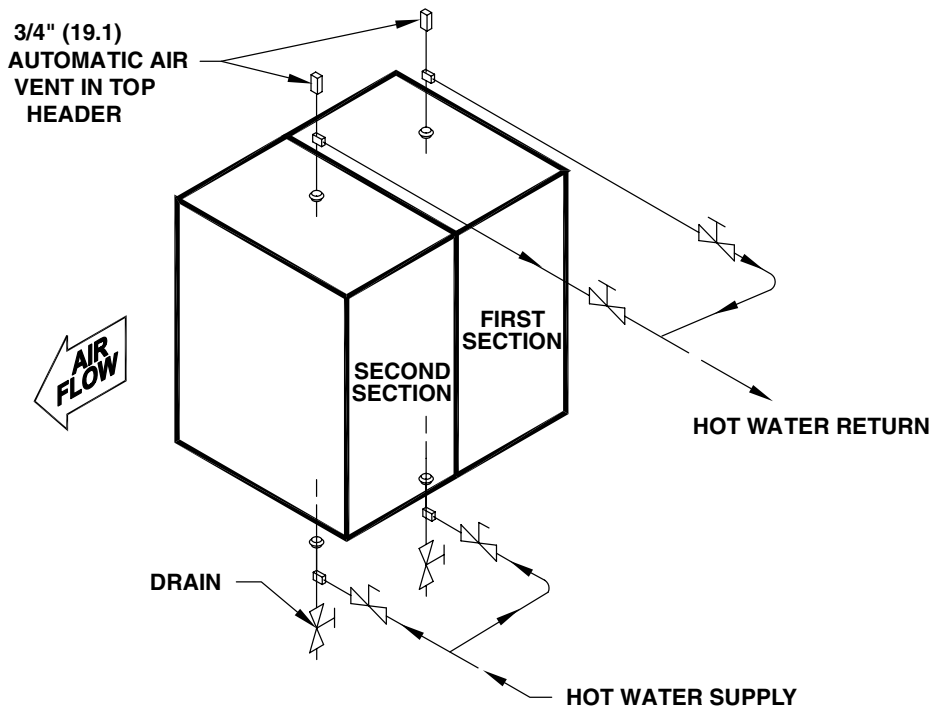

NOTE : DIMENSIONS ARE IN INCHES.
DIMENSIONS IN PARENTHESIS ARE IN MILLIMETERS.

Figure 10 - IFB Steam Piping for Side Header Single Section Coils

STEAM PRESSURE BELOW 15 PSIG OR 103.4 KPA

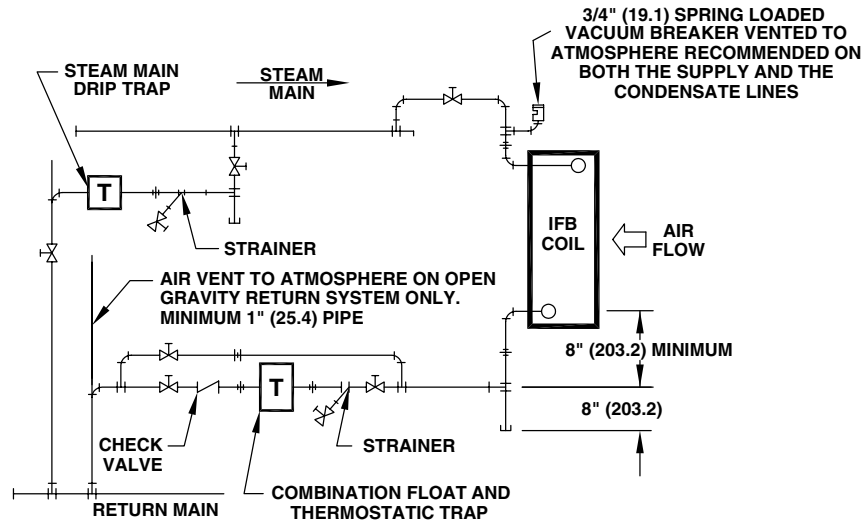

Non-venting Traps
(Steam Pressure Below 15 PSIG Or 103.4 KPa)

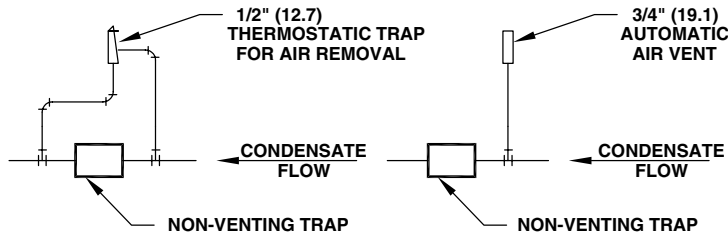

STEAM PRESSURE ABOVE 15 PSIG OR 103.4 KPA

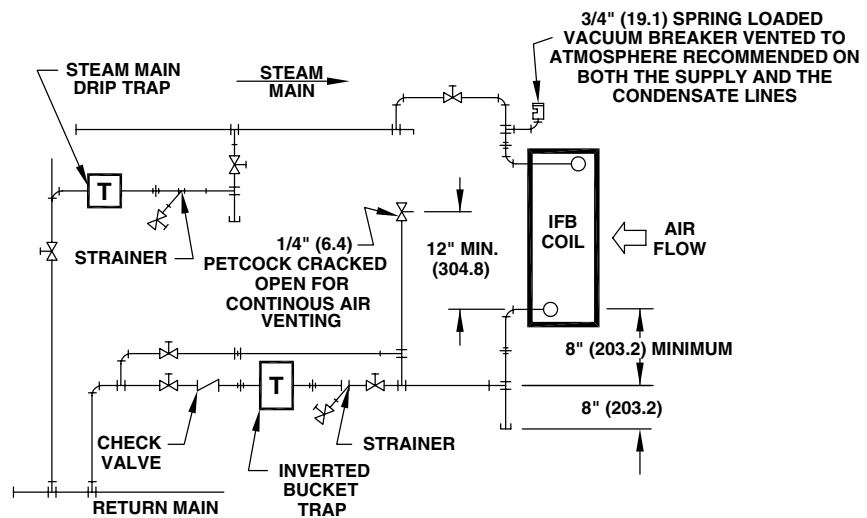

NOTE : DIMENSIONS ARE IN INCHES.
DIMENSIONS IN PARENTHESIS ARE IN MILLIMETERS.

Figure 11 - IFB Steam Piping for Center Header Single Section Coils

STEAM PRESSURE BELOW 15 PSIG OR 103.4 KPA

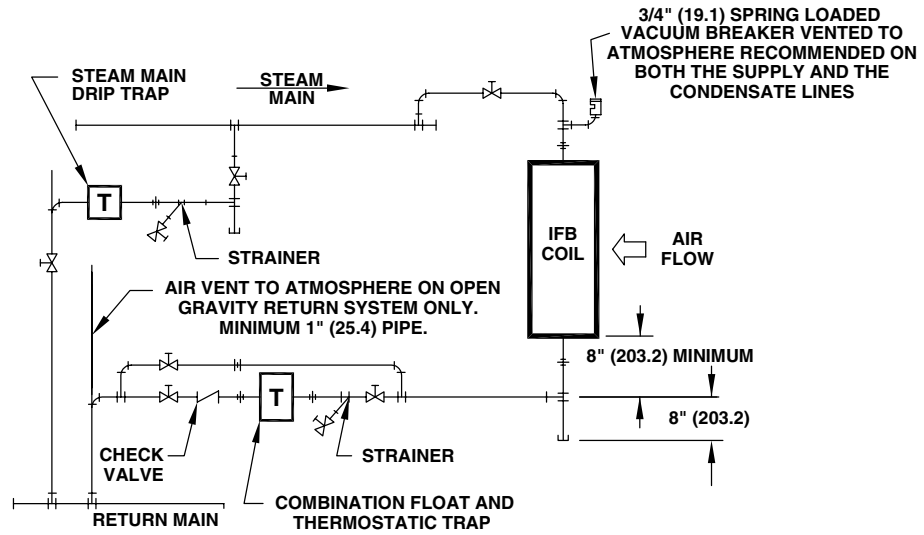

Non-venting Traps
(Steam Pressure Below 15 PSIG Or 103.4 KPa)

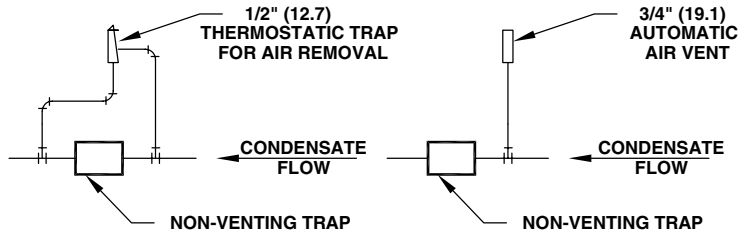

STEAM PRESSURE ABOVE 15 PSIG OR 103.4 KPA

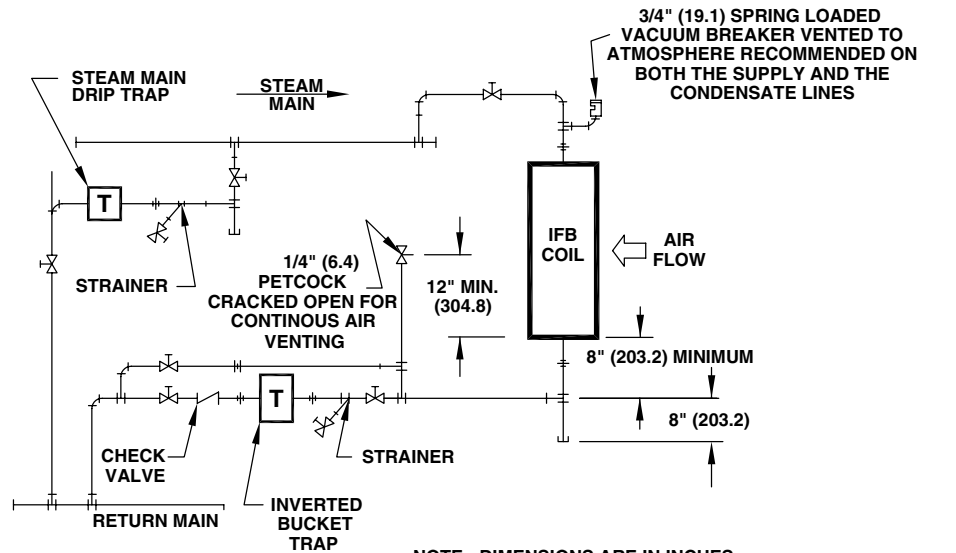

NOTE : DIMENSIONS ARE IN INCHES.
DIMENSIONS IN PARENTHESIS ARE IN MILLIMETERS.

Figure 12 - IFB Steam Piping for Side Header Double Section Coils (Below 15 PSIG)

W14

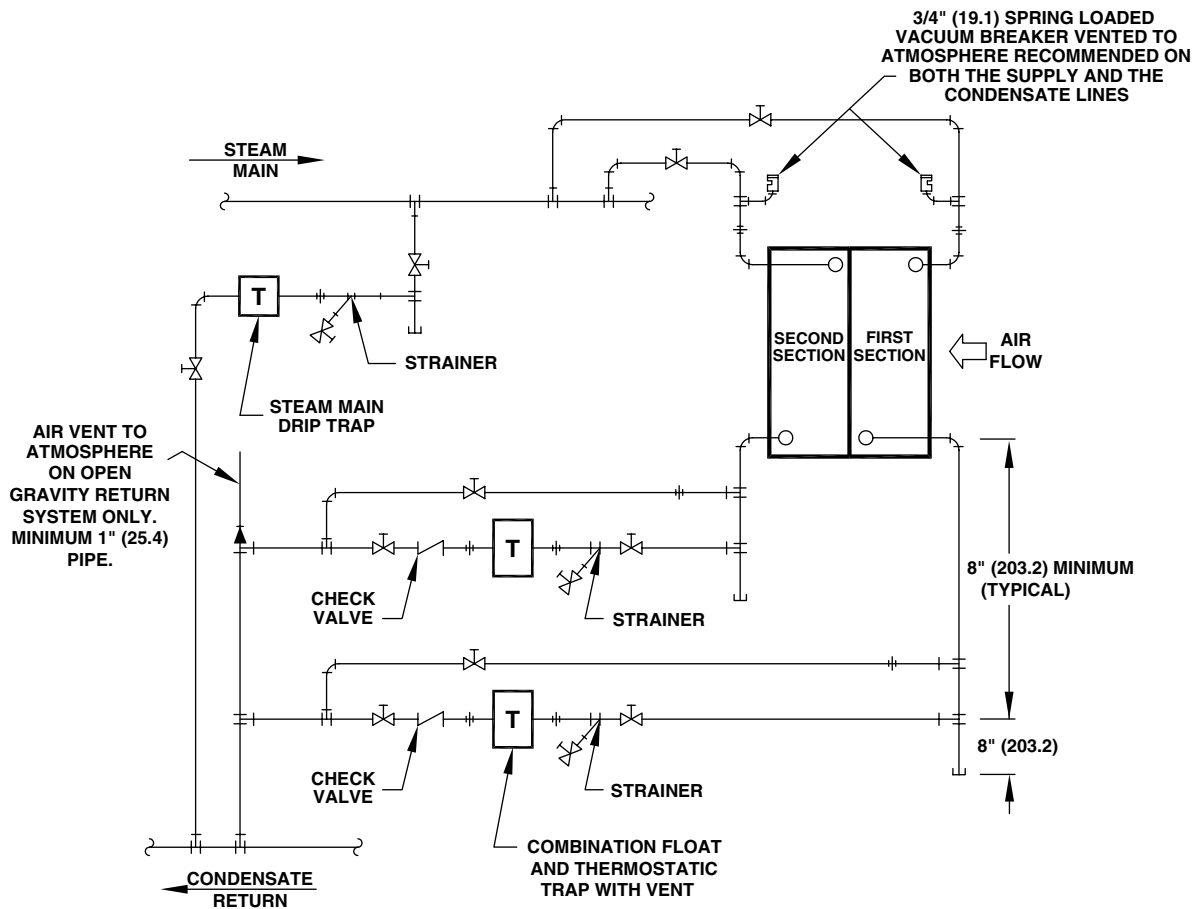

Additional Piping Required For Non-Venting Type Steam Traps

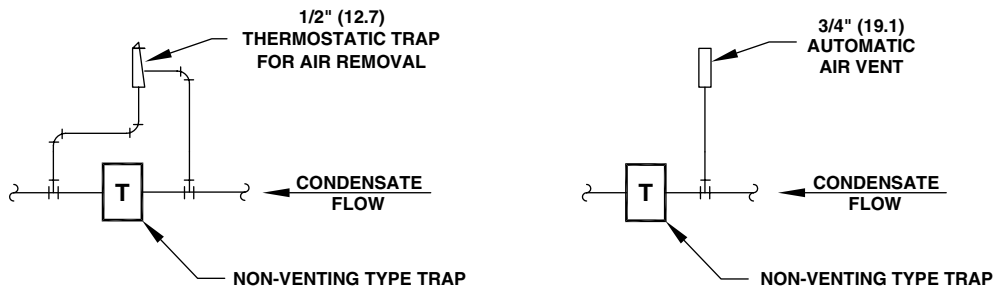

NOTES :

- A. STANDARD IFB COIL STEAM INLET AND CONDENSATE LINE SIZE IS 3" (76.2) NPT.
- B. STEAM MAIN NEEDS TO BE SIZED TO HANDLE STEAM FLOW RATE FOR THE TWO COIL SECTIONS TO BE PIPED IN PARALLEL.
- C. CONDENSATE LINE NEEDS TO BE SIZED TO HANDLE CONDENSATE FLOW RATE FOR THE TWO COIL SECTIONS TO BE PIPED IN PARALLEL.
- D. DIMENSIONS ARE IN INCHES. DIMENSIONS IN PARENTHESIS ARE IN MILLIMETERS.

Figure 13 - IFB Steam Piping for Center Header Double Section Coils (Below 15 PSIG)

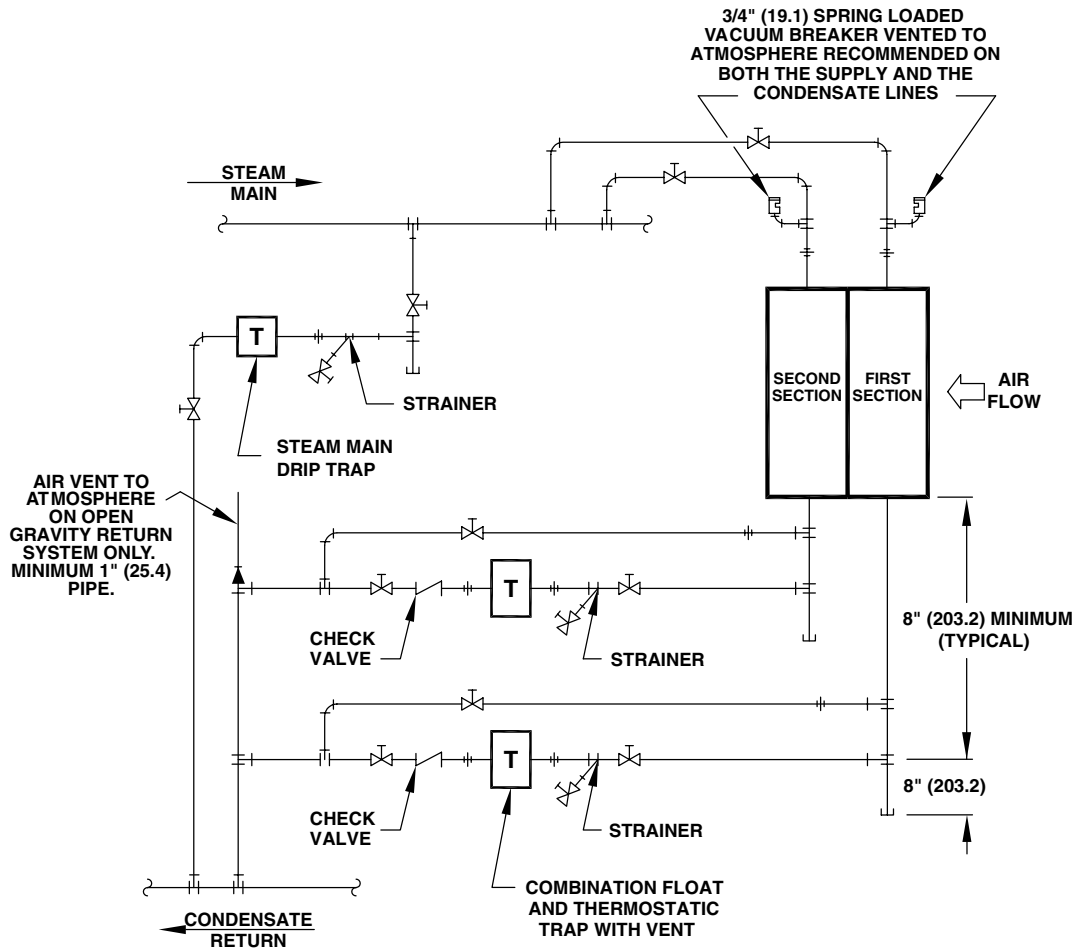

Additional Piping Required For Non-Venting Type Steam Traps

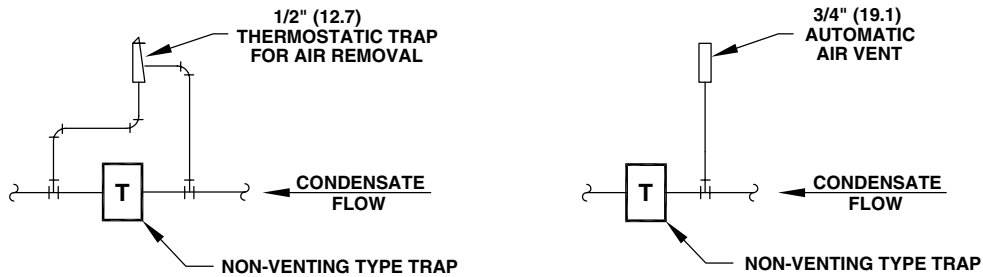

NOTES :

- A. STANDARD IFB COIL STEAM INLET AND CONDENSATE LINE SIZE IS 3" (76.2) NPT.
- B. STEAM MAIN NEEDS TO BE SIZED TO HANDLE STEAM FLOW RATE FOR THE TWO COIL SECTIONS TO BE PIPED IN PARALLEL.
- C. CONDENSATE LINE NEEDS TO BE SIZED TO HANDLE CONDENSATE FLOW RATE FOR THE TWO COIL SECTIONS TO BE PIPED IN PARALLEL.
- D. DIMENSIONS ARE IN INCHES. DIMENSIONS IN PARENTHESIS ARE IN MILLIMETERS.

Figure 14 - IFB Steam Piping for Side Header Double Section Coils (15 PSIG and Above)

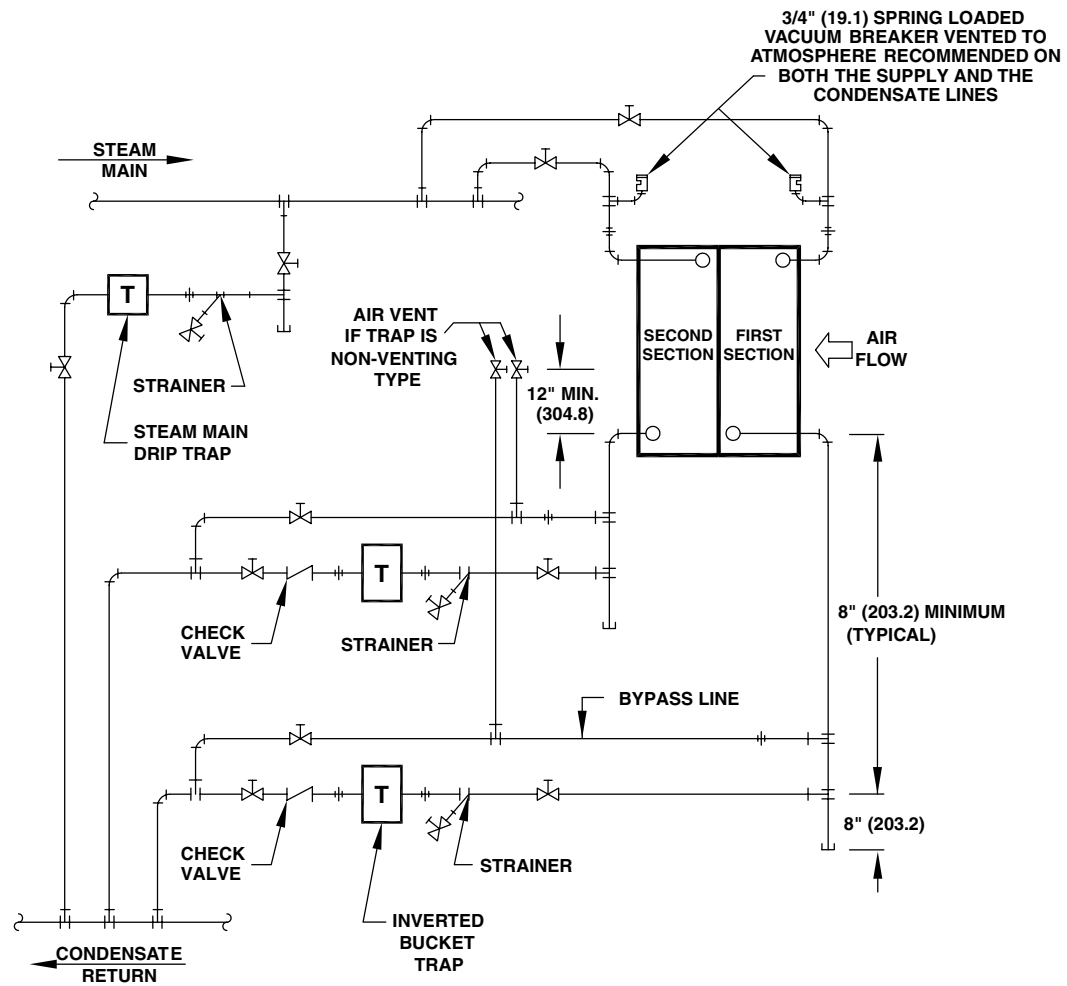

NOTES :

- A. STANDARD IFB COIL STEAM INLET AND CONDENSATE LINE SIZE IS 3" (76.2) NPT.
- B. STEAM MAIN NEEDS TO BE SIZED TO HANDLE STEAM FLOW RATE FOR THE TWO COIL SECTIONS TO BE PIPED IN PARALLEL.
- C. CONDENSATE LINE NEEDS TO BE SIZED TO HANDLE CONDENSATE FLOW RATE FOR THE TWO COIL SECTIONS TO BE PIPED IN PARALLEL.
- D. DIMENSIONS ARE IN INCHES. DIMENSIONS IN PARENTHESIS ARE IN MILLIMETERS.

Figure 15 - IFB Steam Piping for Center Header Double Section Coils (15 PSIG and Above)

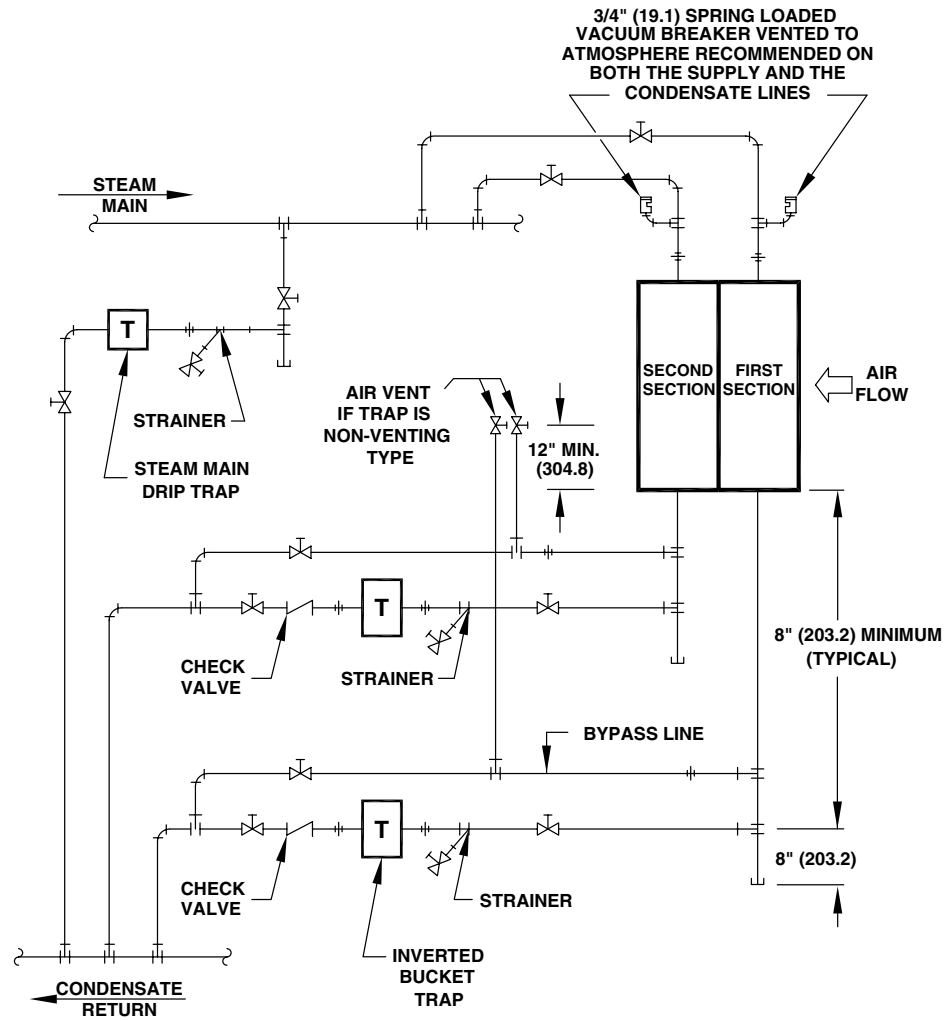

NOTES :

- A. STANDARD IFB COIL STEAM INLET AND CONDENSATE LINE SIZE IS 3" (76.2) NPT.
- B. STEAM MAIN NEEDS TO BE SIZED TO HANDLE STEAM FLOW RATE FOR THE TWO COIL SECTIONS TO BE PIPED IN PARALLEL.
- C. CONDENSATE LINE NEEDS TO BE SIZED TO HANDLE CONDENSATE FLOW RATE FOR THE TWO COIL SECTIONS TO BE PIPED IN PARALLEL.
- D. DIMENSIONS ARE IN INCHES. DIMENSIONS IN PARENTHESIS ARE IN MILLIMETERS.

SECTION VII - CONTROL INSTALLATION AND ADJUSTMENT

A. The IFB controls airstream temperature by changing face and by-pass damper positions in response to the signal produced by an airstream thermostat in the downstream ductwork. IFB coils may be furnished with or without controls. When controls are factory furnished, the damper motors are installed and adjusted for the correct stroke at the factory; no field adjustments are required.

B. Damper operators which are installed at the job site require stroke adjustments.

CAUTION: Extreme care must be taken to prevent damage to IFB tubes or header when installing damper operator. The damper operator stroke must not exceed the stroke required for full damper movement or damage to the dampers, shafts or cranks may occur. Contact your local Wing representatives for installation position and adjustment instructions for the damper operators of the manufacturer's type being installed. If dampers do not move through full stroke, check to see if the damper operator mounting screws are limiting damper movement.

C. Standard location of damper operators is on the left hand side of the IFB coil when looking in the direction of airflow through the coil. Right hand mounting of damper operator is optional, if ordered that way. On IFB side header units, damper operator must be mounted on the same side as the header.

D. The airstream thermostat must be located in the downstream ductwork a minimum of 3 ft. away from the coil. The thermostat element must be positioned across both face and by-pass sections of the coil (parallel to the header). (See Fig. 18.)

E. Control installation instructions, including diagrams, are enclosed in the instruction envelope when special controls and control arrangements are ordered. Typical electric and pneumatic control arrangements are indicated in Figures 16 & 17. A variety of control manufacturers may be used. Please contact the factory for individual control specifications.

Figure 16 - Typical Pneumatic Controls Wiring Diagram

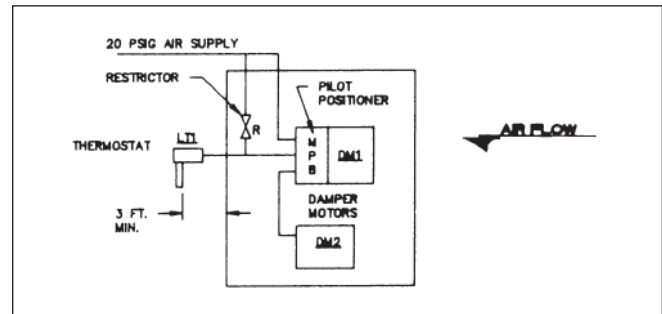
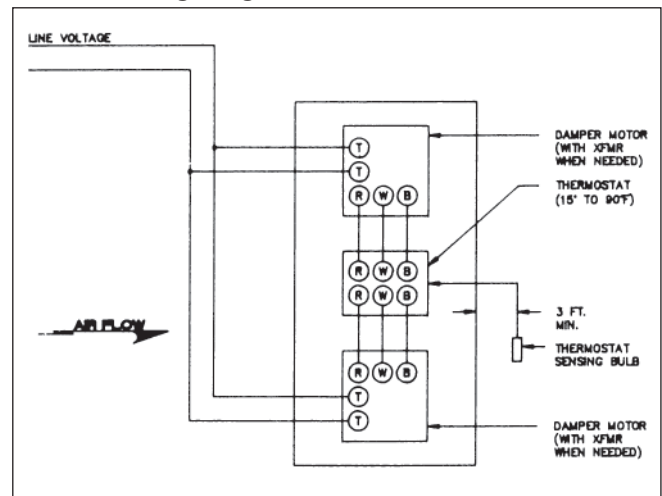

Figure 17 - Typical Electric Controls Wiring Diagram



SECTION VIII - START UP

A. Control Checks

1. On unit with PNEUMATIC CONTROLS, apply full air pressure and remove shipping strap from damper operator. Remove all air pressure from operator. Damper should go to full face open position. Application of full air pressure will close the dampers in the opposite direction. Adjust the thermostat setting to be sure that when thermostat is calling for heat, face dampers open and bypass dampers close.
2. On units with ELECTRIC CONTROLS, follow control manufacturer's instructions for shorting out thermostat contacts to move the dampers to close the face one way, and then the by-pass. Adjust thermostat setting to be sure operation is correct so that when thermostat is calling for heat, the face dampers open and the by-pass dampers close.

NOTE: ON ELECTRIC CONTROL UNITS, SINCE MOTORS ARE NOT SPRING RETURN, DAMPERS WILL REMAIN IN THEIR LAST OPERATING POSITION WHEN POWER IS TURNED OFF.

B. Turning Steam Coil On

1. Open all valves on return lines, including trap valves and by-pass line around trap, to insure full flow of condensate and steam from the coil.
2. Open all valves in drip trap line from steam main before the coil to remove condensate and insure dry steam in the main.
3. Open steam supply line to coil and blow through coil with steam to purge coil of air and condensate.
4. Feel tube surfaces to assure even heating of all surfaces before starting fans or opening outside air shutoff damper.
5. Slowly close bypass valve around trap.
6. Allow unit to heat soak for at least 15 minutes before starting fan or opening outside air shut off damper.
7. Check coil surface for even heating as in step #4.

8. Open outside air damper and start fan.
9. Set thermostat for desired temperature; face and bypass dampers should position to produce required leaving air temperature.

C. Turning Hot Water Coil On

1. Open return valve and supply valve. Purge all air from coil and lines.
2. Feel surface to make sure unit is heating evenly and that all air is purged from the coils.
3. Allow unit to "soak" for at least 10 minutes before turning fan on or opening outside air shut-off damper.
4. Open outside air damper and start fan.
5. Feel surface again to check for even heating as in step #2.
6. Adjust balancing valve for desired GPM flow through coil.
7. Set thermostat for desired temperature. Face and bypass dampers should position to produce required temperature rise.

Figure 18 - Side Elevation Of Coil

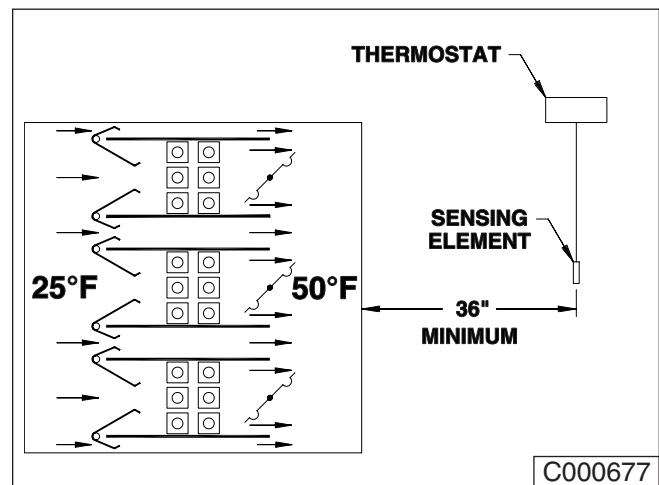

SECTION IX - SHUT DOWN

- A. Shut off system air fan.
- B. Close outside air shut-off dampers.
- C. If air temperature at the coil is above 35°F, shut off steam valve and trap valves (on hot water coil, shut off supply and return valve).

D. As soon as possible, open drip leg in return main (on steam units), or drain and air valves (on hot water units), and allow water to drain.

E. A COIL WHICH HAS BEEN SHUT DOWN SHOULD NOT BE EXPOSED TO SUB-FREEZING AIR FLOW AS WATER DROPLETS IN TUBES MAY FREEZE, RESULTING IN COIL FREEZE-UP WHEN COIL IS RESTARTED. (See starting instructions.)

SECTION X - MAINTENANCE

A. The Wing IFB heating coil should be periodically inspected for continuous satisfactory operation. Loose nuts, bolts, screws and damper linkage should be tightened. Crank arm pivots, control linkage, and damper rods should be checked for wear and replaced if worn.

B. Steam traps should be checked for proper operation. Strainers, dirt pockets and drip legs should be cleaned periodically. Air vent valve on hot water installations should be checked for proper operation.

SECTION XI - TUBE REMOVAL AND REPLACEMENT

A. Tube Removal

1. Turn off the fan and close the outside air damper.
2. Turn off the steam or hot water, drain the coil, and allow to cool.
3. Remove both inlet dampers provided on each tube bundle.
4. Use a 5/16" socket to remove the (2) 10 x 1/2 hex head screws holding the tube hanger to the bypass. Pull the tube hanger toward you and remove.
5. Use the 5/16" socket to remove the (2) 10 x 1/2 hex head screws holding the tube support bracket to the side panel. Remove the bracket.
6. a. Standard Brazed Tube Connection - Cut off the bad tubes from the supply header, leaving approximately 2" long stubs.
b. Optional Nut and Flare Tube Connection - Use a 1-1/16" open end line wrench to loosen the nuts holding the bad tubes in the supply header.
7. Remove the 1/4-20 x 5/8 hex head bolt and washer holding the discharge damper to the damper shaft at the header. Remove the discharge damper and damper shaft which extends through the side panel.
8. Use the 5/16" socket to remove the (2) 10 x 1/2 hex head screws holding the tube hanger to the bypass. Pull the tube hanger toward you and remove.
9. Use the 5/16" socket to remove the (2) 10 x 1/2 hex head screws holding the tube support bracket to the side panel. Remove the bracket.
10. Remove the tube support from the end of the tubes.
11. a. Standard Brazed Tube Connection - Cut off the bad tubes, leaving approximately 2" long stubs, from the return header.
b. Optional Nut and Flare Tube Connection - Use a 1-1/16" open end line wrench to loosen the nuts holding the bad tubes in the return header.
12. Push tubes toward the side panel and out of the headers. Pull the tubes at the return bend and remove. Use a torch to heat brazed joints and remove the remaining stubs.

B. Tube Repair

1. Water hammer damage is identified by a bulge, or bulges, on the bottom of the tube. Water hammer literally hammers a hole in the tube. This can be repaired with silver solder or by replacing the tube. To prevent steam hammer damage, install a drip trap in the steam supply line just before the coil.
2. Freeze-up damage is identified by a bulge and typically a rupture in the U-bend of the tube. This can be repaired with silver solder or by replacing the tube. Freeze-up is caused when condensate does not flow properly. This can be caused by intermittent steam supply, by a defective condensate trap, or by condensate return system back-pressure or restriction. Find the cause and correct it, or freeze-up problems will continue.

C. Tube Replacement

1. a. Standard Brazed Tube Connection - Clean around the tube joints on headers where new tubes will be installed with a good grade of cleaning flux. Braze new tubes in place using a brazing material suitable for brazing the tubes into the header.
b. Optional Nut and Flare Tube Connection - Clean all connections before assembling. Make certain that tubes to be re-used are re-installed in the exact same holes they were removed from. Failure to re-install the tubes in the correct holes will probably result in a leaky joint which can only be remedied by replacement with a new nut and flare connection.
2. Turn on steam or hot water and test for leaks. Turn off steam or hot water.
3. Attach tube support to U-bends.
4. Re-install tube support brackets.
5. Re-install tube hangers. (Make certain the hanger is installed so the distance from the support clip to the top of the hanger is least on the steam side and the distance from the upper clip to the top of the hanger is greatest on the condensate side.)
6. Re-install the dampers.
7. Turn on the steam or hot water and check for leaks at tube to header joint.
8. After 15 minutes "heat soak" time, open the outside air damper and start the fan.



4830 Transport Drive, Dallas, TX 75247
Tel: (214) 638-6010 • Fax: (214) 905-0806
www.ljwing.com

