

REVISIONS		
REV.	EN NO.	DATE
F	10630	08/31/16

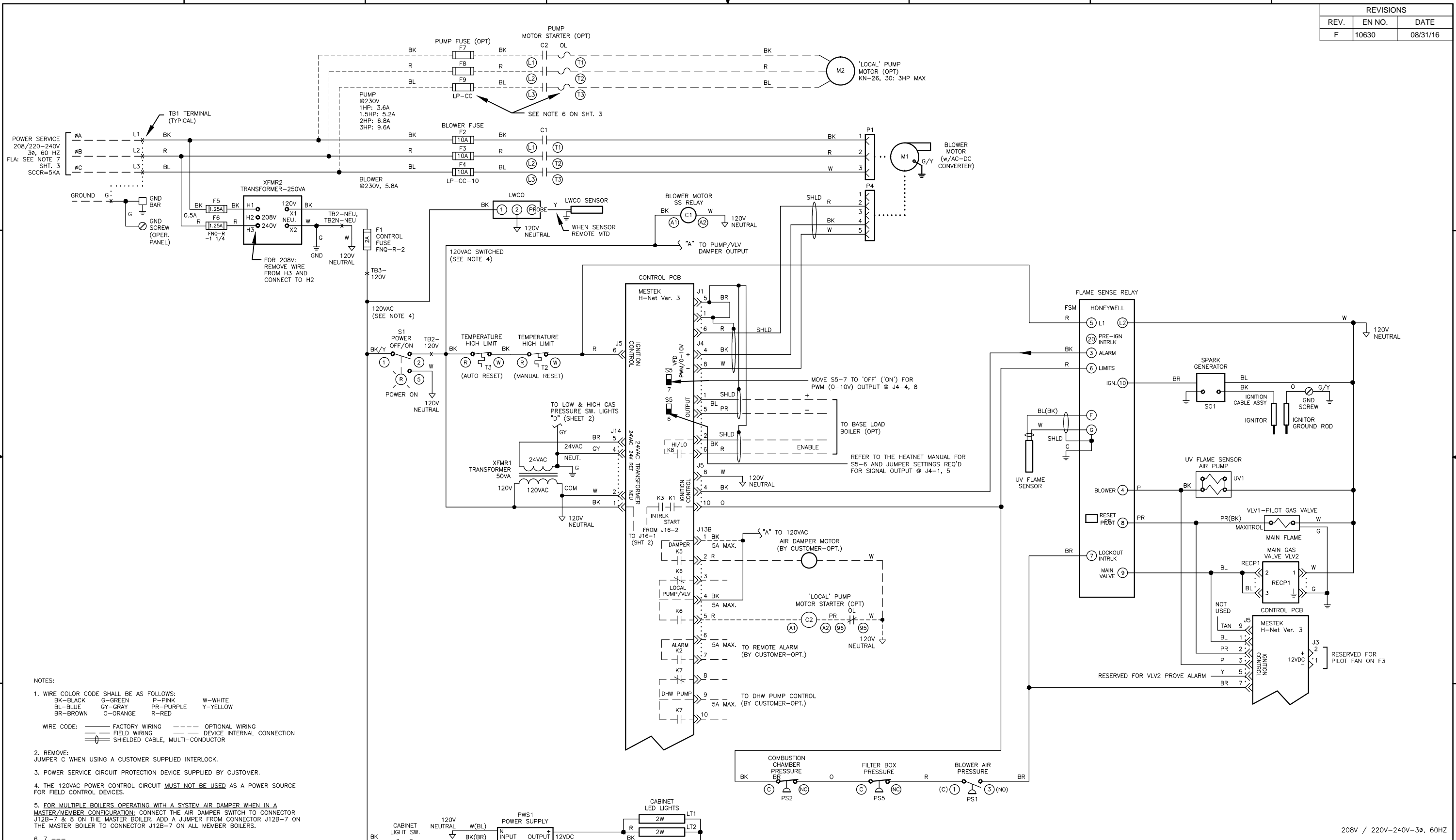

- NOTES:
- WIRE COLOR CODE SHALL BE AS FOLLOWS:
 BK-BLACK G-GREEN P-PINK W-WHITE
 BL-BLUE GY-GRAY PR-PURPLE Y-YELLOW
 BR-BROWN O-ORANGE R-RED
 - REMOVE JUMPER C WHEN USING A CUSTOMER SUPPLIED INTERLOCK.
 - POWER SERVICE CIRCUIT PROTECTION DEVICE SUPPLIED BY CUSTOMER.
 - THE 120VAC POWER CONTROL CIRCUIT **MUST NOT BE USED** AS A POWER SOURCE FOR FIELD CONTROL DEVICES.
 - FOR MULTIPLE BOILERS OPERATING WITH A SYSTEM AIR DAMPER WHEN IN A MASTER/MEMBER CONFIGURATION: CONNECT THE AIR DAMPER SWITCH TO CONNECTOR J12B-7 & 8 ON THE MASTER BOILER, ADD A JUMPER FROM CONNECTOR J12B-7 ON THE MASTER BOILER TO CONNECTOR J12B-7 ON ALL MEMBER BOILERS.
 - 7 ---
 - HEATNET ONLINE, STAGE 2, 3, 4 AND SYSTEM PUMP 2 OUTPUTS ARE NOT AVAILABLE WITH THE H-NET 'LITE' CONTROL PCB.

DIVISION	PRODUCT	DRAWN BY	DATE	DRAWING DESCRIPTION			
ATH	KN-26 TO 30	RT	09/26/12	LADDER DIAGRAM			
THE PRINT AND ALL INFORMATION THEREON IS PROPERTY OF THE ATH DIVISION OF MESTEK, INC. NEITHER THE PRINT NOR THE INFORMATION THEREON MAY BE REPRODUCED OR USED IN ANY MANNER WHATSOEVER OR DIVULGED TO ANY OTHER PERSON UNLESS SPECIFICALLY AUTHORIZED BY MESTEK, INC.			CHECKED BY	DATE	DRAWING NUMBER		
			RT	09/26/12	42-00003		
			APPROVED BY	DATE	SHEET	SHEET SIZE	SCALE
			JPC	10/15/12	1 of 4	B	N/A
							REVISION
							F

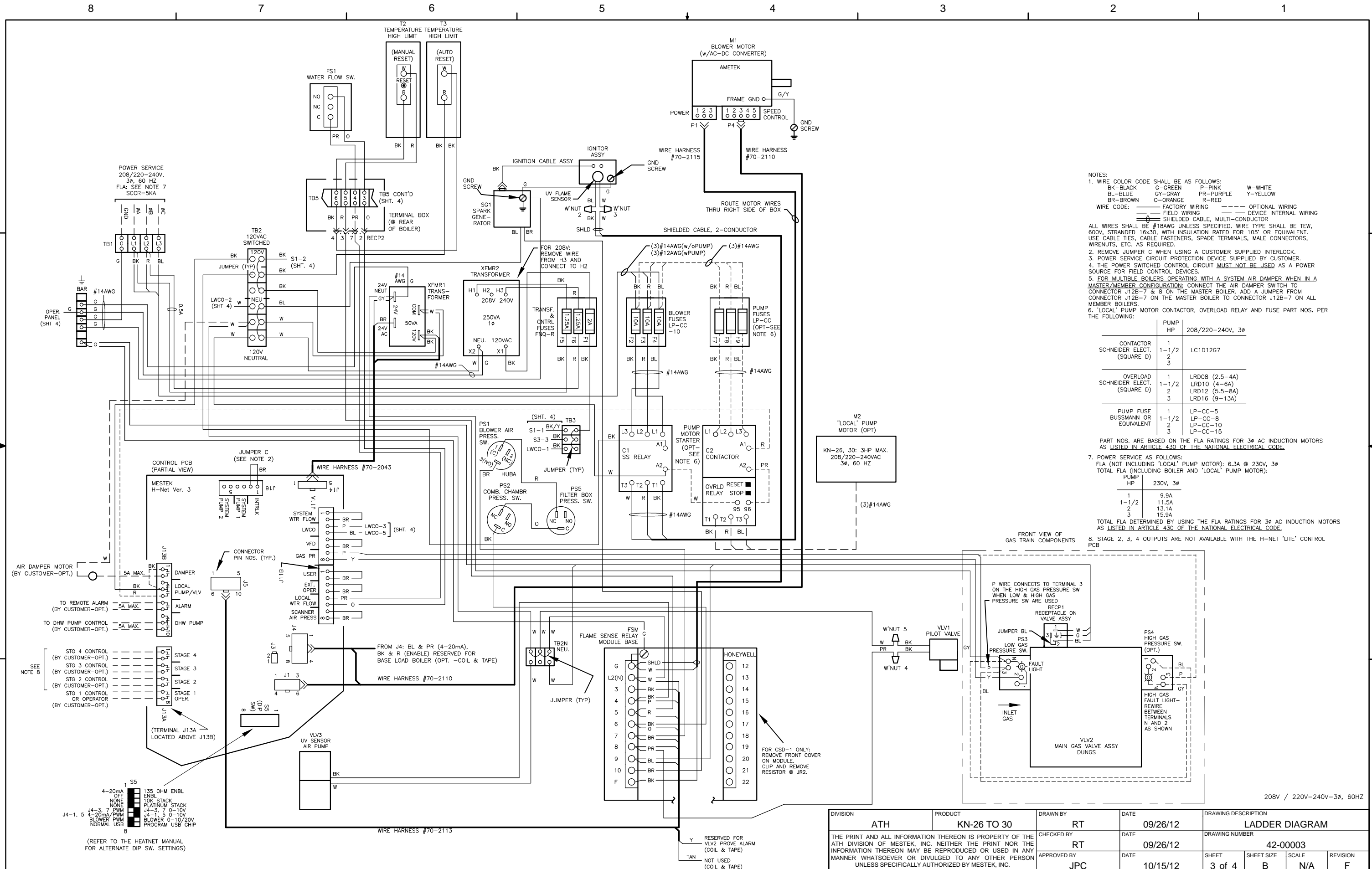

NOTES:

- WIRE COLOR CODE SHALL BE AS FOLLOWS:
 BK-BLACK G-GREEN P-PINK W-WHITE
 BL-BLUE GR-GRAY PR-PURPLE Y-YELLOW
 BR-BROWN O-ORANGE R-RED
- WIRE CODE: — FACTORY WIRING — OPTIONAL WIRING
 — FIELD WIRING — DEVICE INTERNAL WIRING
 — SHIELDED CABLE, MULTI-CONDUCTOR
- ALL WIRES SHALL BE #18AWG UNLESS SPECIFIED. WIRE TYPE SHALL BE TEW, 600V, STRANDED 16X30, WITH INSULATION RATED FOR 105° OR EQUIVALENT. USE CABLE TIES, CABLE FASTENERS, SPADE TERMINALS, MALE CONNECTORS, WIRENUTS, ETC. AS REQUIRED.
- REMOVE JUMPER C WHEN USING A CUSTOMER SUPPLIED INTERLOCK.
- POWER SERVICE CIRCUIT PROTECTION DEVICE SUPPLIED BY CUSTOMER.
- THE POWER SWITCHED CONTROL CIRCUIT MUST NOT BE USED AS A POWER SOURCE FOR FIELD CONTROL DEVICES.
- FOR MULTIPLE BOILERS OPERATING WITH A SYSTEM AIR DAMPER WHEN IN A MASTER/MEMBER CONFIGURATION: CONNECT THE AIR DAMPER SWITCH TO CONNECTOR J12B-7 & 8 ON THE MASTER BOILER. ADD A JUMPER FROM CONNECTOR J12B-7 ON THE MASTER BOILER TO CONNECTOR J12B-7 ON ALL MEMBER BOILERS.
- 'LOCAL' PUMP MOTOR CONTACTOR, OVERLOAD RELAY AND FUSE PART NOS. PER THE FOLLOWING:

	PUMP HP	208/220-240V, 3φ
CONTACTOR SCHNEIDER ELECT. (SQUARE D)	1	LC1D12G7
	1-1/2	
	2	
OVERLOAD SCHNEIDER ELECT. (SQUARE D)	1	LRD08 (2.5-4A)
	1-1/2	LRD10 (4-6A)
	2	LRD12 (5.5-8A)
PUMP FUSE BUSSMANN OR EQUIVALENT	1	LP-CC-5
	1-1/2	LP-CC-8
	2	LP-CC-10
	3	LP-CC-15

PART NOS. ARE BASED ON THE FLA RATINGS FOR 3φ AC INDUCTION MOTORS AS LISTED IN ARTICLE 430 OF THE NATIONAL ELECTRICAL CODE.

7. POWER SERVICE AS FOLLOWS:
 FLA (NOT INCLUDING 'LOCAL' PUMP MOTOR): 6.3A @ 230V, 3φ
 TOTAL FLA (INCLUDING BOILER AND 'LOCAL' PUMP MOTOR):

PUMP HP	230V, 3φ
1	9.9A
1-1/2	11.5A
2	13.1A
3	15.9A

TOTAL FLA DETERMINED BY USING THE FLA RATINGS FOR 3φ AC INDUCTION MOTORS AS LISTED IN ARTICLE 430 OF THE NATIONAL ELECTRICAL CODE.

8. STAGE 2, 3, 4 OUTPUTS ARE NOT AVAILABLE WITH THE H-NET 'LITE' CONTROL PCB

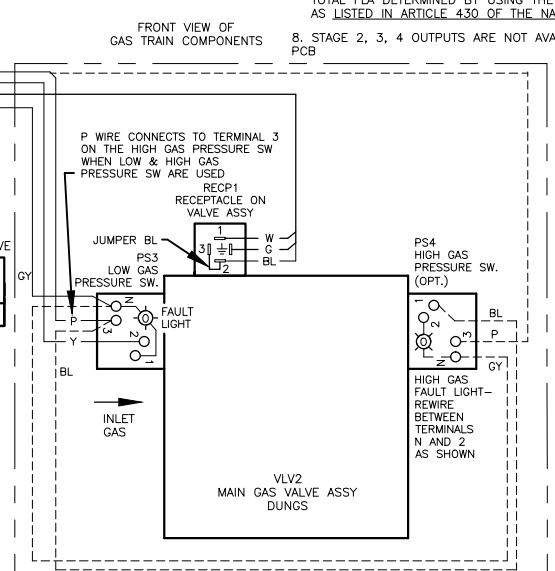

4-20mA OFF 135 OHM ENBL
 NONE 10K STACK
 NONE PLATINUM STACK
 J4-3, 7 PWM J4-3, 7 0-10V
 J4-1, 5 4-20mA/PWM BLOWER 0-10/20V
 NORMAL USB PROGRAM USB CHIP

(REFER TO THE HEATNET MANUAL FOR ALTERNATE DIP SW. SETTINGS)

DIVISION	PRODUCT	DRAWN BY	DATE	DRAWING DESCRIPTION
ATH	KN-26 TO 30	RT	09/26/12	LADDER DIAGRAM
THE PRINT AND ALL INFORMATION THEREON IS PROPERTY OF THE ATH DIVISION OF MESTEK, INC. NEITHER THE PRINT NOR THE INFORMATION THEREON MAY BE REPRODUCED OR USED IN ANY MANNER WHATSOEVER OR DIVULGED TO ANY OTHER PERSON UNLESS SPECIFICALLY AUTHORIZED BY MESTEK, INC.		CHECKED BY	DATE	DRAWING NUMBER
		RT	09/26/12	42-00003
APPROVED BY	DATE	SHEET	SHEET SIZE	SCALE
JPC	10/15/12	3 of 4	B	N/A
				REVISION
				F

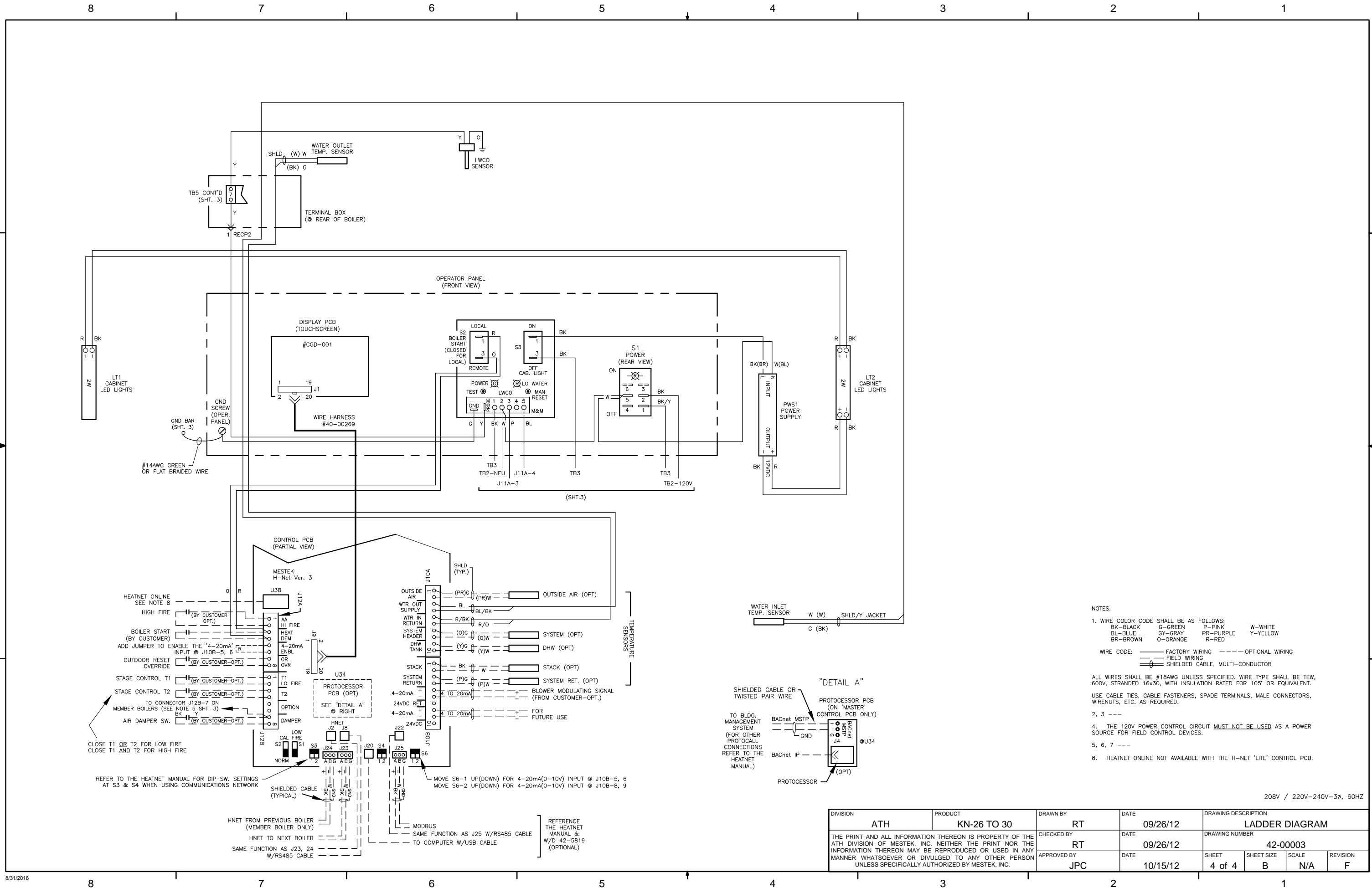

- NOTES:
1. WIRE COLOR CODE SHALL BE AS FOLLOWS:
 BK-BLACK G-GREEN P-PINK W-WHITE
 BL-BLUE GY-GRAY PR-PURPLE Y-YELLOW
 BR-BROWN O-ORANGE R-RED
 2. 3 ---
 WIRE CODE: --- FACTORY WIRING - - - - - OPTIONAL WIRING
 --- FIELD WIRING
 --- SHIELDED CABLE, MULTI-CONDUCTOR
 3. ---
 4. THE 120V POWER CONTROL CIRCUIT **MUST NOT BE USED** AS A POWER SOURCE FOR FIELD CONTROL DEVICES.
 - 5, 6, 7 ---
 8. HEATNET ONLINE NOT AVAILABLE WITH THE H-NET 'LITE' CONTROL PCB.

208V / 220V-240V-3ø, 60HZ

DIVISION	PRODUCT	DRAWN BY	DATE	DRAWING DESCRIPTION		
ATH	KN-26 TO 30	RT	09/26/12	LADDER DIAGRAM		
THE PRINT AND ALL INFORMATION THEREON IS PROPERTY OF THE ATH DIVISION OF MESTEK, INC. NEITHER THE PRINT NOR THE INFORMATION THEREON MAY BE REPRODUCED OR USED IN ANY MANNER WHATSOEVER OR DIVULGED TO ANY OTHER PERSON UNLESS SPECIFICALLY AUTHORIZED BY MESTEK, INC.			CHECKED BY	DATE	DRAWING NUMBER	
			RT	09/26/12	42-00003	
APPROVED BY	DATE	SHEET	SHEET SIZE	SCALE	REVISION	
JPC	10/15/12	4 of 4	B	N/A	F	