

ONEX

Submittal Data

Residential
Wall-Mounted Gas Boiler

Model 160 condensing boilers utilize a patented tri-parallel flow heat exchanger and state of the art premix air/gas modulation firing system for optimal combustion. Boilers have AFUE ratings of 91.1% and come in a convenient space saving wall-hung design. Units are offered in both “combi” and “heat only” configurations.

“Combi” units provide both hydronic heat and semi-instantaneous hot water all in one complete compact package. “Combi” units include as standard features a mounted and wired system circulator pump and expansion tank.

“Heat only” units are offered with no integral domestic hot water package allowing customers the use of their current hot water supply equipment. “Heat only” models can be easily piped to an indirect fired storage tank for additional storage capacity.

All units utilize a panel mounted “on-board” electronic control platform that allow for easy set-up and custom system configuration.

Boilers are installation and maintenance friendly. All fuel and water utility connections are conveniently located at the bottom of the unit, external to the cabinet for ease of connection and service. Top of its class for performance and safety.

VENTING

The 160 series is designed to be used with a concentric vent kit that can be vented either vertically or side-wall for application flexibility. Concentric vent kits allow the use of outside air for combustion, lowering fuel bills by reducing air infiltration. Kits are flexible and easy to install and can be vented up to 70 equivalent feet. Boilers can also be vented with pvc material. This will allow the installer additional venting options and ease the venting system installation.

DOMESTIC HOT WATER

Enjoy ample low-cost domestic hot water without the expense of a separate water heater. The domestic water coil is integrated into the boiler cabinet and easily removed for annual maintenance. Producing up to 4 gallons per minute, the semi-instantaneous copper coil configuration has plenty of capacity for your hot water needs. A new and improved design allows for easy, automatic air purge on boiler operation.



STANDARD FEATURES (“Combi & Heat only” units)

- 91.1% AFUE
- ASME heat exchanger
- Patented tri-parallel flow stainless steel tubes
- Premix burner technology
- Full 5:1 modulation (30,000 – 160,000 btuh)
- Environmentally friendly – low NOx – less than 15 ppm SCAQMD approved
- Space saving wall mount
- Easily converted from natural to L.P. gas
- Outdoor air sensor

STANDARD FEATURES (“Combi” only)

- Semi-instantaneous domestic hot water coil (4 GPM) with auto air purge
- Integral system circulator pump
- Integral expansion tank and air vent

Quantity	Model Number	Description
_____	<input type="checkbox"/> OX-160C	Combination Heat/DHW
_____	<input type="checkbox"/> OX-160B	Heat Only



345 Oser Avenue, Hauppauge, NY 11788
(631) 694-1800 Fax: (631) 694-1832
www.embassyind.com

A MESTEK COMPANY

PROJECT: _____ DATE: _____
 LOCATION: _____
 ARCHITECT: _____
 ENGINEER: _____
 CONTRACTOR: _____
 PO NUMBER: _____

ONEX

Submittal Data

Residential
Wall-Mounted Gas Boiler

RATINGS AND ENGINEERING DATA

Nominal heat input	160,000 Btu/hr
Minimum heat input	30,000 Btu/hr
Efficiency	91.1%*
*DOE Heating capacity is based on standard test specified by the United States Department of Energy.	
D.H.W. heat output	142,400 Btu/hr
Instantaneous D.H.W. production (75°F rise)	4 gal/min
Maximum heating temperature	190°F
Maximum heating pressure	30 Psi
Maximum pressure of domestic hot water circuit	125 Psi
Capacity of expansion tank	2.64 gal
Nominal power supply voltage	120/60 V/Hz
Electric power	170 W
Flue gas pipes diameter (split) (polypropylene)	3"
Flue gas pipes max. length (split) (polypropylene)	300 ft
Flue gas pipes diameter (concentric) (polypropylene)	2.36" / 3.94"
Flue gas pipes max. length (concentric) (polypropylene)	70 ft
CO contents (0% O ₂ with natural gas)	15 p.p.m.
NOx contents (0% O ₂ with natural gas)	15 p.p.m.
Dimensions LxDxH (approximate)	20" x 10" x 33"
Connections (supply - return - D.H.W. - D.C.W. - gas)	3/4"
Weight	100 lbs

* AFUE (DOE Seasonal Efficiency) %

DIMENSIONS

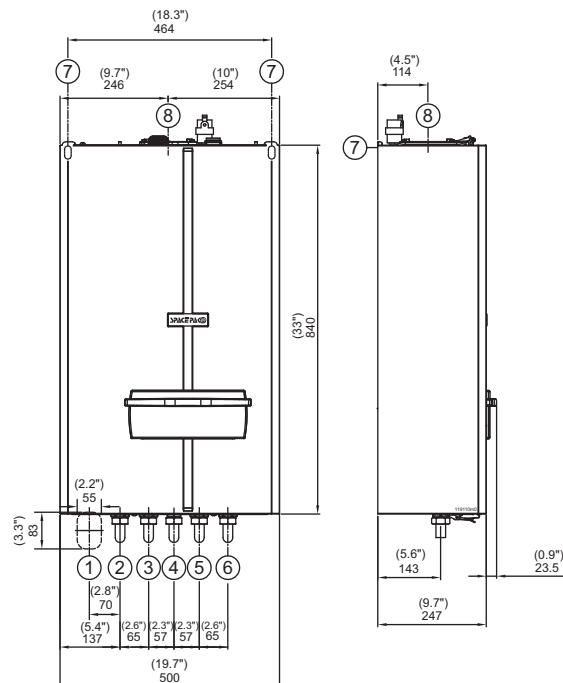

N°	Description	Connections
1	Area for power supply cable	/
2	Heating supply connection	3/4" SWEAT
3	DHW connection	3/4" SWEAT
4	Gas connection	3/4" NPT
5	DCW connection	3/4" SWEAT
6	Heating return	3/4" SWEAT
7	Position for boiler support	/
8	Flue discharge/air intake connection	/