



SYSTEM 6

High Capacity  
Hot Water Baseboard

**E** EMBASSY  
INDUSTRIES  
Inc.



# SYSTEM 6

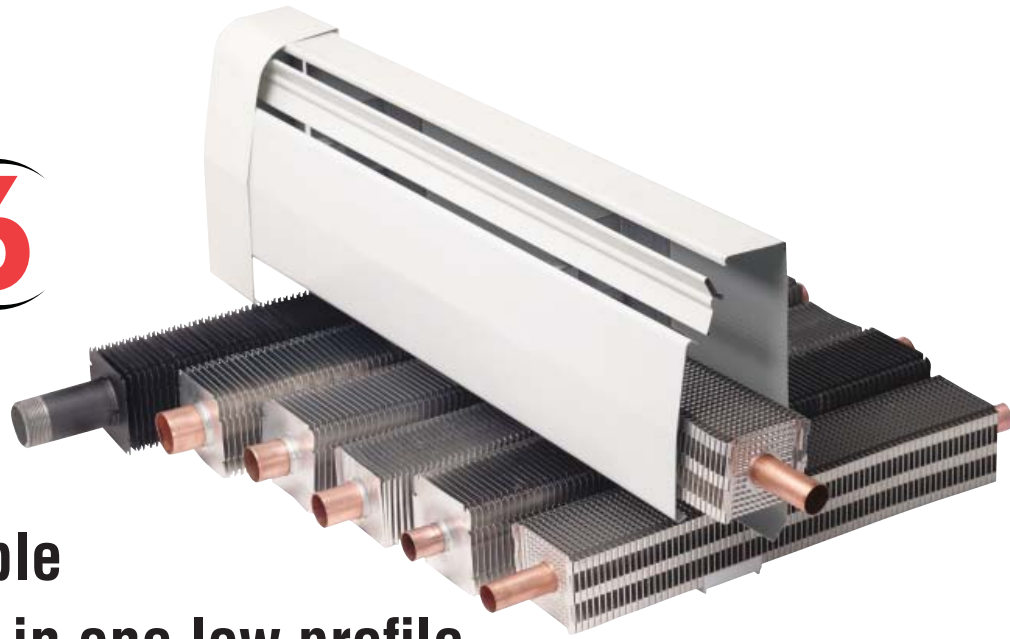

## Six interchangeable heating elements in one low profile enclosure for any residential or light commercial job.

### The Ultimate in Flexibility and Design

System 6 is a heavy-duty baseboard heating product that provides specifying engineers and contractors a choice of six interchangeable high output heating elements in one low profile enclosure. This allows for more design flexibility than any competitor's baseboard. System 6's low profile makes it ideal where space is at a premium, while the extra-high heat outputs of all six elements meet nearly every heating requirement.

System 6 is one of the most rugged baseboards available for any residential or light commercial installation. Its 18-gauge steel front panel and heavy-duty support brackets make System 6 ideal for heavy traffic areas such as offices, apartments and building corridors as well as any home. Plus System 6 comes in a white baked enamel finish that blends with any decor. System 6 features a fully modulating damper for individual room control and its "easy glide" expansion cradles assure noise free operation. For high-capacity baseboard heating at a competitive price, specify System 6.

### Snap-On Dampers

Finger-touch snap-on damper opens and closes with ease, without the use of hinges which can bind or loosen with age.

### Heavy-Duty Front Panel

With a rugged 18-gauge steel front panel, there's none heavier in the industry. This sturdy front panel resists dents and always looks new, year after year.

### Easy Installation

All copper/aluminum heating elements have an expanded end for easy sweat connections without couplings. The 1-1/4" IPS steel element is threaded at both ends.

### Rugged Support Brackets

System 6 is constructed with strong, heavy gauge support brackets which will stand up to years of wear and tear without bending or tattering in any way.

### Tube Support System

System 6's unique tube support design allows for fast and easy installation of a return line.

### Six Interchangeable Elements

With a choice of six interchangeable elements, each with a different output and capacity, our System 6 is ideal for virtually any type of installation.

#### Copper/Aluminum Elements:

- SCE-632A (3/4" with 2-1/2" x 2-3/4" fins)
- SCE-633 (3/4" with 3" x 3-1/4" fins)
- SCE-642A (1" with 2-1/2" x 2-3/4" fins)
- SCE-643 (1" with 3" x 3-1/4" fins)
- SCE-653 (1-1/4" with 3" x 3-1/4" fins)

#### IPS Steel Elements:

- SCE-655 (1-1/4" with 3" x 3-1/4" fins)

### Expansion Cradles

Easy glide polypropylene expansion cradles are attached to the fins on all six elements over the support brackets, which eliminate noisy metal to metal contact between the brackets and the enclosure. This guarantees smooth, quiet operation for years to come.

## Accessories



### End Cap

3" wide left (SCC-L) and right (SCC-R), for use at doorways and wherever a finished end is needed. 3" wide slotted left (SCCS-L) and right (SCCS-R), for through-the-wall connections. Fully telescopic.



### Outside Corner

90° (SOC-90) and 135°/45° (SOC-135). Use to trim corners at projecting wall. Telescopic up to 1" on each wall.



### Valve Enclosure

9" wide left (SVE-L) and right (SVE-R). Extra wide 6" hinged door for easy access to valve or vent. Fully telescopic.



### Valve Enclosure (slotted)

9" wide left (SVES-L) and right (SVES-R). Extra wide 6" hinged door for easy access to valve or vent. Fully telescopic.



### Inside Corner

90° (SIC-90) and 135°/45° (SIC-135). One piece snap-on for easy installation. Telescopic up to 2-1/2" on each wall.



### Extension Sets

14" wide (SEX-14). Four sections (back, front, top and damper). Telescopes to fill gaps up to 12-1/2" between baseboard panels.



### Wall Joiners

5" (SWJ-5) and 9" (SWJ-9). Fully telescopic to conceal connecting pipes.

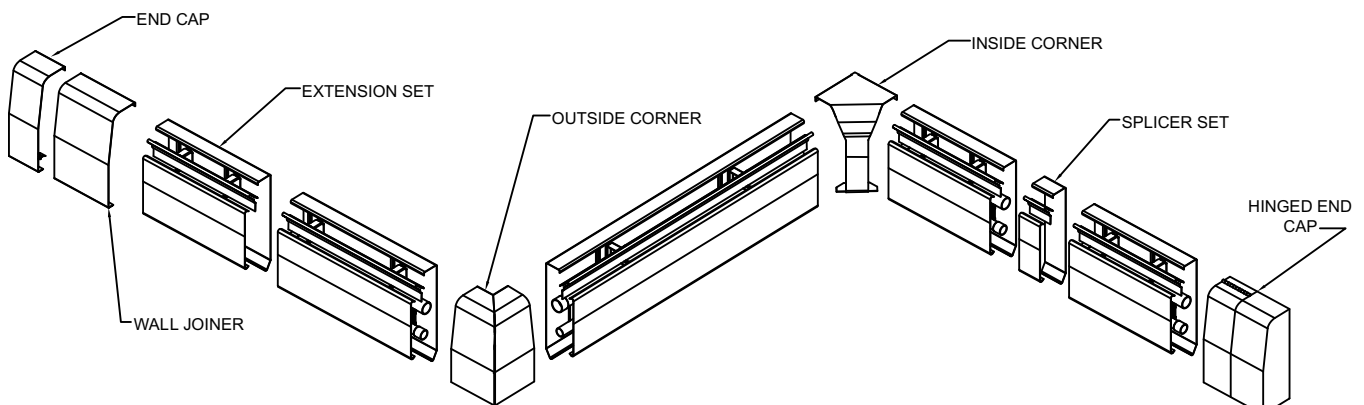

BIOM-004

# Specifications

## Ratings

Model	GPM	Tube/Fin	Tube Size	Average Hot Water Temperature °F - BTU/Hr./Lin./Ft.									
				120°	130°	140°	150°	160°	170°	180°	190°	200°	210°
SCE-632A	4	Copper/Al	3/4"	269	342	414	466	549	640	740	820	910	990
	1			255	323	392	441	519	610	700	780	860	940
SCE-633	4	Copper/Al	3/4"	316	401	486	547	644	770	870	970	1070	1160
	1			299	380	460	518	610	730	820	920	1010	1100
SCE-642A	4	Copper/Al	1"	267	338	410	461	543	640	730	810	900	980
	1			252	320	388	437	514	610	690	770	850	930
SCE-643	4	Copper/Al	1"	307	389	472	531	625	740	840	930	1040	1130
	1			290	368	446	502	591	700	790	880	980	1070
SCE-653	4	Copper/Al	1 1/4"	295	375	454	511	602	710	800	900	990	1090
	1			306	388	470	529	623	670	760	850	940	1030
SCE-655	4	IPS Steel	1 1/4"	252	320	388	437	514	610	690	770	850	930
	1			239	304	368	414	488	580	650	730	800	880

**NOTE:** All the above ratings are based on active length, which is 4" less than total length, and includes a 15% addition for heating effect. The use of these ratings at 2000 lb/hr is limited to installations where the water flow rate through the baseboard unit is equal to or greater than 2000 lb/hr. Where the flow rate through the baseboard is not known; the rating at 500 lb/hr. must be used.

## Dimensional Data

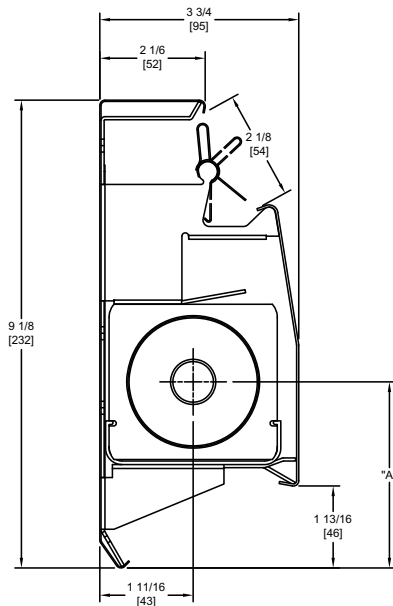

"A" DIMENSIONS

SCE	632A	633	642A	643	653	655
"A"	3 1/2	3 5/8	3 1/2	3 5/8	3 5/8	3 5/8

### Model SCE-632A

3/4" Nominal Copper Tubing with 2-1/2"x2-3/4"x.010" thick aluminum fins (natural finish) x 58 fins per ft. Pressure Drop (in ft. of head per 100 ft. - ft./100 ft.) @ 1 GPM = 0.32 ft./100 ft. and @ 4 GPM = 4.16 ft./100 ft. Bursting Pressure 1412 psi.; Operating Pressure 283 psi.

### Model SCE-633

3/4" Nominal Copper Tubing with 3"x3-1/4"x.020" thick aluminum fins (natural finish) x 51 fins per ft. Pressure Drop (in ft. of head per 100 ft. - ft./100 ft.) @ 1 GPM = 0.32 ft./100 ft. and @ 4 GPM = 4.16 ft./100 ft. Bursting Pressure 1412 psi.; Operating Pressure 283 psi.

### Model SCE-642A

1" Nominal Copper Tubing with 2-1/2"x2-3/4"x.010" thick aluminum fins (natural finish) x 58 fins per ft. Pressure Drop (in ft. of head per 100 ft. - ft./100 ft.) @ 1 GPM = 0.09 ft./100 ft. and @ 4 GPM = 1.13 ft./100 ft. Bursting Pressure 1082 psi.; Operating Pressure 216 psi.

### Model SCE-643

1" Nominal Copper Tubing with 3"x3-1/4"x.020" thick aluminum fins (natural finish) x 51 fins per ft. Pressure Drop (in ft. of head per 100 ft. - ft./100 ft.) @ 1 GPM = 0.09 ft./100 ft. and @ 4 GPM = 1.13 ft./100 ft. Bursting Pressure 1082 psi.; Operating Pressure 216 psi.

### Model SCE-653

1-1/4" Nominal Copper Tubing with 3"x3-1/4"x.020" thick aluminum fins (natural finish) x 51.5 fins per ft. Pressure Drop (in ft. of head per 100 ft. - ft./100 ft.) @ 1 GPM = 0.03 ft./100 ft. and @ 4 GPM = 0.41 ft./100 ft. Bursting Pressure 1556 psi.; Operating Pressure 311 psi.

### Model SCE-655

1-1/4" IPS Steel Pipe with 3"x3-1/4"x.026" thick steel fins (painted finish) x 48 fins per ft. Pressure Drop @ 4 GPM = 0.35 ft./100 ft. Both ends threaded. Bursting Pressure 7590 psi.; Operating Pressure 1000 psi.