

COIL CONNECTION
(SEE TABLE 1 FOR AVAILABLE OPTIONS)

LINT SCREEN

COMMISS. TUBE

DAMPER LEVER

Ø 1/2" DRAIN CONNECTION

AIR INLET CONNECTION
(SEE TABLE 1 FOR AVAILABLE OPTIONS)

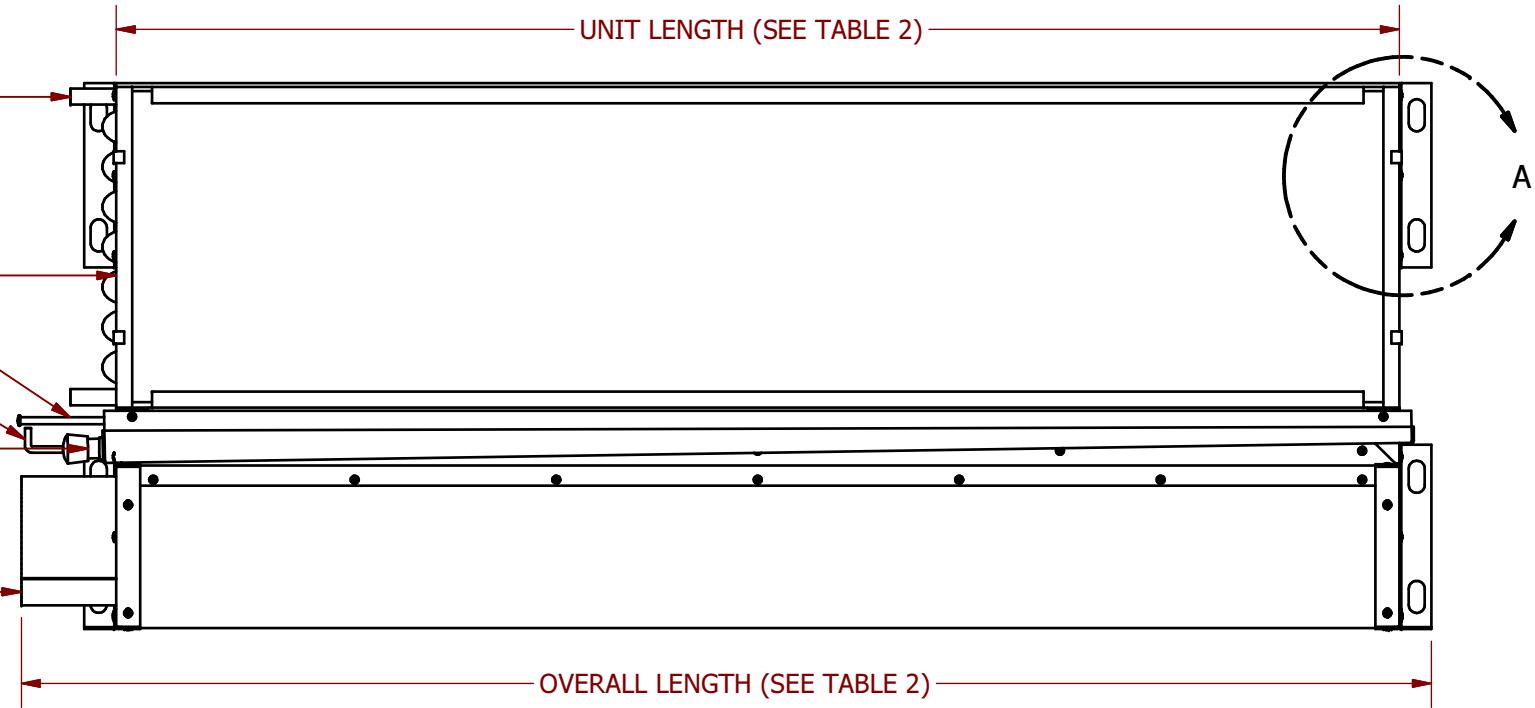
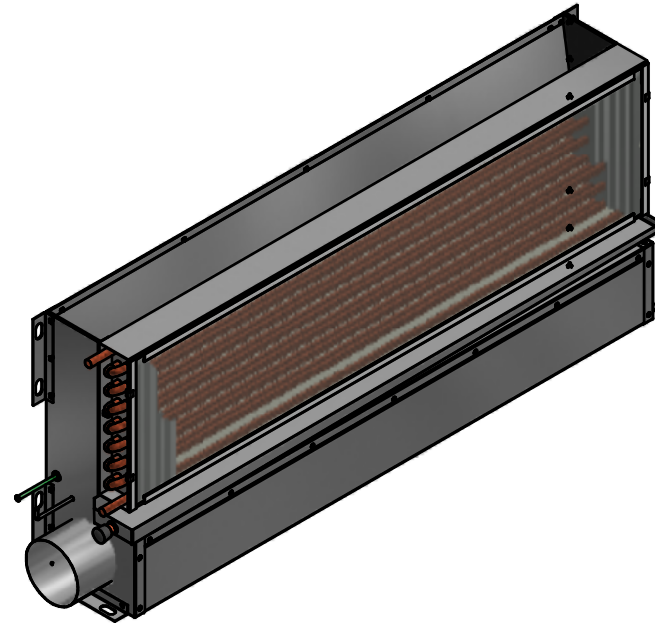
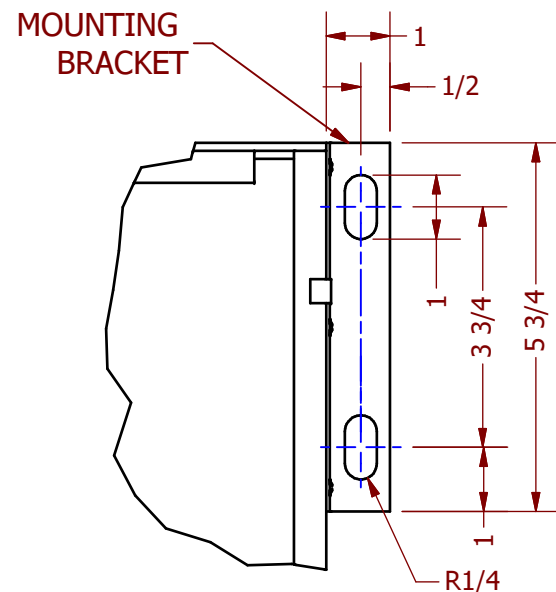

TABLE 1 AVAILABLE OPTIONS	
Ø 1/2" O.D. SWEAT CONNECTION	<input checked="" type="checkbox"/>
Ø 1/2" FEMALE NPT CONNECTION	<input type="checkbox"/>
Ø 1/2" MALE NPT CONNECTION	<input type="checkbox"/>
AIR INLET SIZE 3" 4"	<input checked="" type="checkbox"/> <input type="checkbox"/>
WALL MOUNTING	<input checked="" type="checkbox"/>
FLOOR MOUNTING	<input checked="" type="checkbox"/>
LINT SCREEN	<input checked="" type="checkbox"/>

TABLE 2			
NOMINAL UNIT LENGTH (ft)	UNIT LENGTH (in)	OVERALL LENGTH (in)	WEIGHT (lb)
2	24	28	27
3	32	36	35
4	40	44	42
5	52	56	49
6	64	68	56



NOTE:

- DRAWING INDICATES "A" COIL AND AIR CONNECTION HANDINGS (REFER TO MODEL CONFIGURATION KEY FOR AVAILABLE OPTIONS).
- STANDARD DRAIN CONNECTION HANDING IS SAME AS COIL CONNECTION.

FMTBY MODEL SUBMITTAL DRAWING				
STRICTLY CONFIDENTIAL			DADANCO - A MESTEK CO.	
DADANCO - A MESTEK CO. 47 Westfield Ind. Park Road Westfield, MA 01085 Ph. (413) 564-5657, Fax. (413) 568-2969 www.dadanco.com			FMTBY	
DRN	TS	2/19/2015	TITLE	
CKD	DH	2/19/2015	FMTBY	
APPD	DH	2/19/2015		
ISSUED			PROJECT NO:	File Name:
UNLESS NOTED OTHERWISE ALL DIMENSIONS IN INCHES		ANSI STANDARD	SCALE: NTS	FMTBY_Family.iam
ANGULAR TOL: 1.0° LINEAR TOL: ±0.06"			SHEET: 1/1	RELEASE