

# EXTRUDED ALUMINUM, 0.465" DEEP, FIXED J/K 42° TYPE BLADE

MODEL EA-TL-42  
STANDARD SPECIFICATIONS

FRAME: FRAME OPTIONAL; SEE BACKSIDE OF PAGE.

VBS: 0.465" DEEP HAT CHANNEL, 0.063" THICK 6063-T5 ALUMINUM ALLOY VERTICAL BLADE SUPPORT (VBS).

BLADES: 0.063" THICK 6063-T5 ALUMINUM ALLOY.

FINISH: MILL.

MAX. PANEL SIZE: 96" X 48"

MIN. PANEL SIZE: 12" X 12"

CONTACT FACTORY FOR LOUVER SIZES LARGER THAN 96" X 48".

DIMENSIONS: "A" (WIDTH) AND "B" (HEIGHT) ARE OPENING SIZES. LOUVERS ARE MADE 1/4" UNDERSIZED FOR STANDARD AND OPTIONAL FRAME CONSTRUCTION.

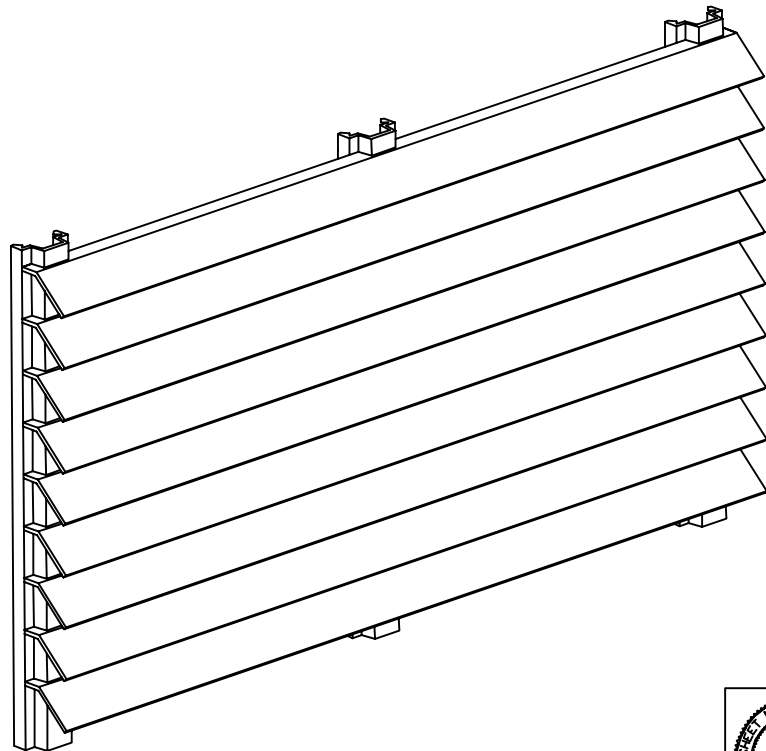
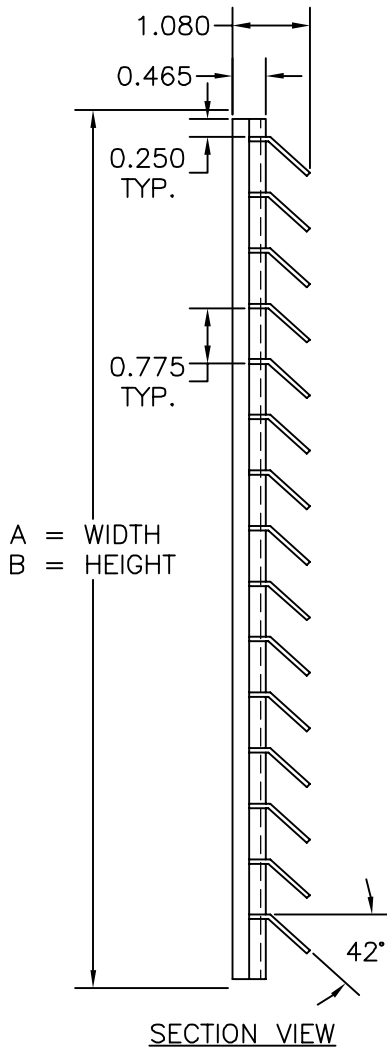

FINISH OPTIONS:

- MILL
- ANODIZED
- PAINTED



**ARROW UNITED INDUSTRIES**  
A DIVISION OF MESTEK, INC.  
450 RIVERSIDE DRIVE  
WYALUSING, PA 18853  
TEL: (570) 746-1888 FAX: (570) 746-9286  
WEB ADDRESS: WWW.ARROWUNITED.COM

AGENT: \_\_\_\_\_

ARCH./ENG.:		
CONTR.:		
PROJECT:		
EDR:	ECN:	JOB:
DATE:	DWN.:	DWG.: