

# ARROW EXTRUDED ALUMINUM LOUVERS ADJUSTABLE TYPE 6" DEEP

# TYPE EA-633

FOR MANUAL OR MOTOR OPERATION

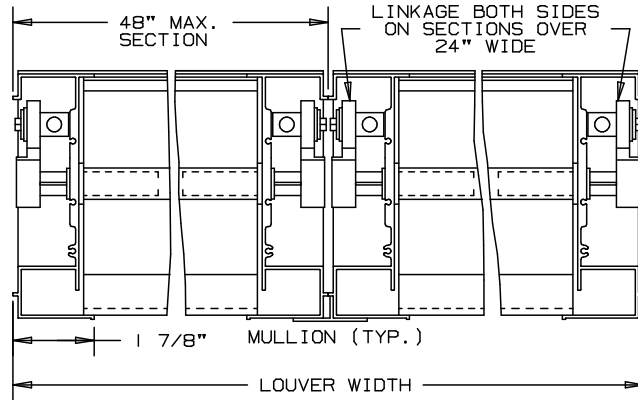
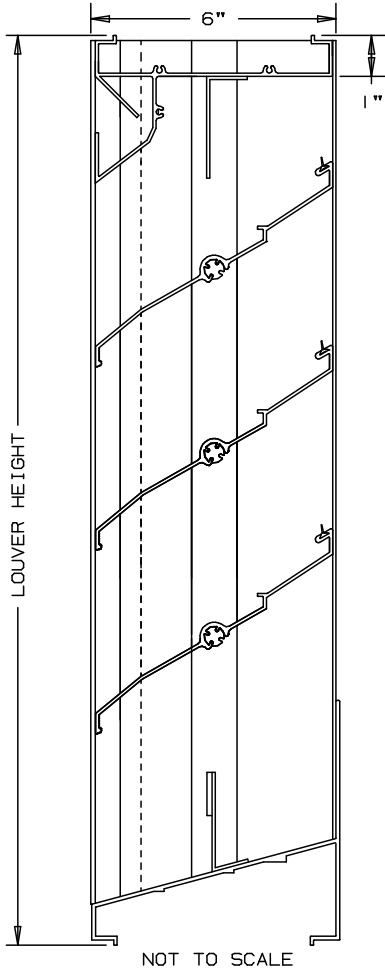

### SPECIFICATIONS

BEARINGS: CELCON BEARING MATERIAL SO THAT THERE WILL BE NO METAL TO METAL FRICTION. OPERATING LINKAGE CONCEALED IN FRAME, OUT OF THE AIR STREAM.

MATERIAL: FRAME AND BLADE EXTRUDED ALUMINUM 6063-T6/T52 ALLOY .080" THK., BLADES ON 4 1/2" CENTERS. FACE OF LOUVER: FULL WIDTH SILL WITH DRAIN HEAD AND NON-DRAIN BLADES CONTAINED WITHIN THE DRAIN JAMBS.

LINKAGE: EXTRUDED ALUMINUM, CONCEALED IN CHANNEL OUT OF AIRSTREAM. PIVOTS ARE .50" DIA. MACHINED STEEL, CADMIUM PLATED AND CHROMATE TREATED. PIVOTS ROTATE IN A CELCON BEARING. A .312" DIA. ALUMINUM LINKAGE ROD IS LOCKED TO THE PIVOT BY A 1/4-20 SET SCREW WITH AN EPOXY LOCKING PATCH.

SHAFTS: .50" DIA. ALUMINUM "PIN-LOCK" ROD.  
SEALS: EXTRUDED SILICONE RUBBER SEAL AT BLADE EDGE. POLYURETHANE AT THE JAMBS.

SCREENS: WHEN INDICATED, IN A REMOVABLE FRAME.  
BIRD SCREEN - 1/2" FLATTENED ALUMINUM, .051" THK.  
OR - 1/2" SQ. MESH, INTERMEDIATE DOUBLE-CRIMPED ALUMINUM WIRE, .063 DIA.  
OR - 18/16 MESH, .011" DIA. ALUMINUM WIRE, INSECT SCREEN.

FINISH: MILL.  
LOUVER SIZES: 12" x 12" MINIMUM PANEL SIZE.  
48" x 96" MAXIMUM PANEL SIZE.

### LOUVER PERFORMANCE STATEMENT

LOUVER MODEL EA-633 SHALL BE FABRICATED TO PROVIDE A MINIMUM OF (57%), 9.06 SQUARE FEET OF FREE AREA FOR A 48" x 48" SIZE LOUVER. TESTED IN ACCORDANCE TO AMCA STANDARD 500-L-99. THE BEGINNING POINT OF WATER PENETRATION AT .01 OUNCES PER SQUARE FOOT OF FREE AREA AT A FREE AREA VELOCITY OF 841 FEET PER MINUTE, (7619) CUBIC FEET PER MINUTE. WITH A .15 INCHES WATER GAUGE PRESSURE DROP AT 1000 FPM FOR AIR INTAKE.

### OPTIONAL

- OTHER SCREENS
- ARCHITECTURAL FINISHES
- ACTUATORS (ELECTRIC, PNEUMATIC, MANUAL, ETC.)

FOR PERFORMANCE DATA  
- SEE REVERSE SIDE

FLANGE FRAME (AVAILABLE EITHER FACE)

1 3/8" USABLE FLANGE

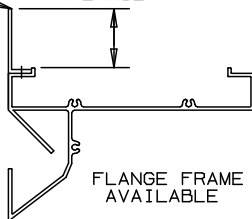

FLANGE FRAME AVAILABLE

NOMINAL DEDUCTIONS WILL BE MADE TO THE OPENING SIZES GIVEN.

ITEM	QTY.	WIDTH	HEIGHT	WIDTH	HEIGHT	MULL	TYPE	LOC
		OPENING SIZE		LOUVER SIZE				

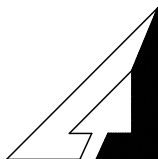

ARROW UNITED INDUSTRIES  
A DIVISION OF MESTEK, INC.

450 RIVERSIDE DRIVE  
WYALUSING, PA 18853

TEL: (570) 746-1888 FAX: (570) 746-9286  
WEB ADDRESS: WWW.ARROWUNITED.COM

AGENT: \_\_\_\_\_

ARCH./ENG.:

CONTR.:

PROJECT:

EDR:

ECN:

JOB:

DATE:

DWN.:

DWG.:

# LOUVER MODEL EA-633

## ADJUSTABLE LOUVERS

### EXTRUDED ALUMINUM - NON-DRAIN

## PERFORMANCE DATA

TESTS OF A 48" X 48" SAMPLE BY AN \*AMCA REGISTERED LABORATORY ACCORDING TO AMCA STANDARD 500 SHOWS LESS THAN .02 OZ. PER SQ. FT. WATER PENETRATION AT 865 FPM (FREE AREA VELOCITY) WITH LESS THAN .11" W.G. PRESSURE DROP (INTAKE).

RATINGS DO NOT INCLUDE THE EFFECT OF BIRDSCREEN.

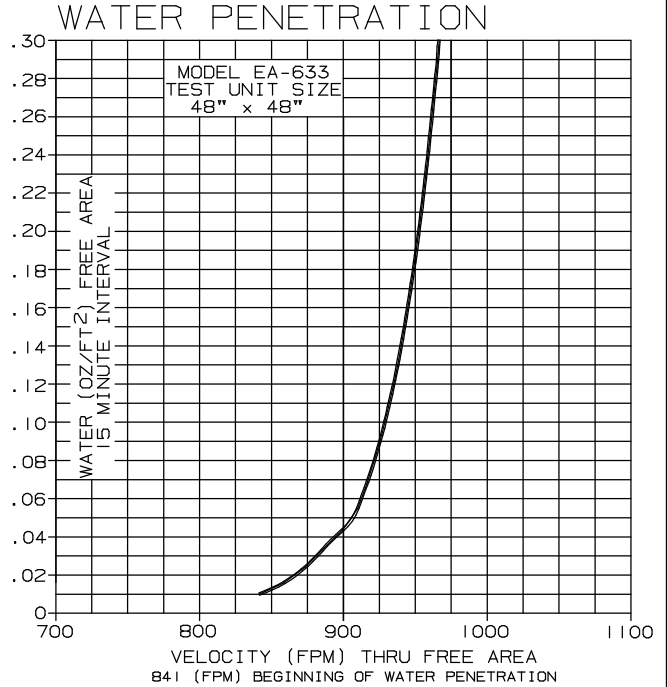
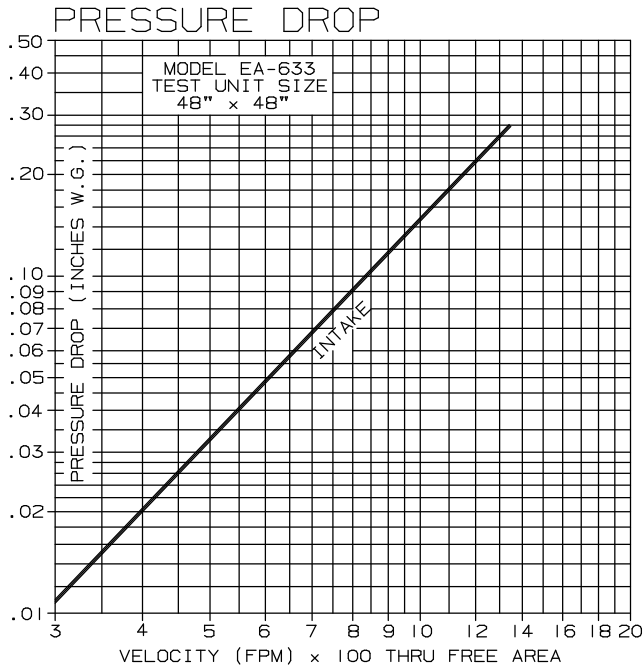

## FREE AREA

		FREE AREA ( SQ. FT. )						
		WIDTH						
HEIGHT	12"	.21	.36	.51	.67	.82	.98	1.13
	24"	.54	.94	1.35	1.75	2.15	2.56	2.96
	36"	1.04	1.81	2.59	3.37	4.15	4.92	5.70
	48"	1.53	2.69	3.84	4.99	6.14	7.29	9.06
	60"	1.87	3.27	4.67	6.07	7.47	8.87	10.27
	72"	2.37	4.14	5.91	7.69	9.46	11.23	13.01
	84"	2.86	5.01	7.16	9.31	11.45	13.60	15.75
	96"	3.20	5.59	7.99	10.39	12.78	15.18	17.58

\* AMCA REGISTERED LABORATORY IS A LABORATORY EQUIPPED AND STAFFED TO CONDUCT TESTS ACCORDING TO THE APPROPRIATE AMCA TESTS METHOD AND WHICH HAS BEEN LICENSED AS A AMCA REGISTERED LABORATORY.