

ARROW EXTRUDED ALUMINUM THERMAL BREAK DAMPERS

TYPE AFDTI-25

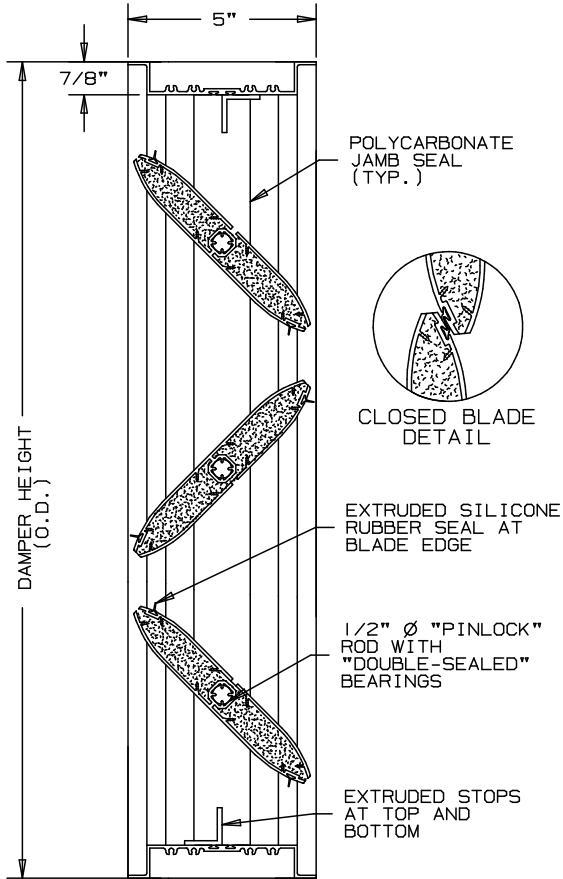

OPPOSED BLADE DAMPER (SHOWN)
PARALLEL BLADE DAMPER AVAILABLE

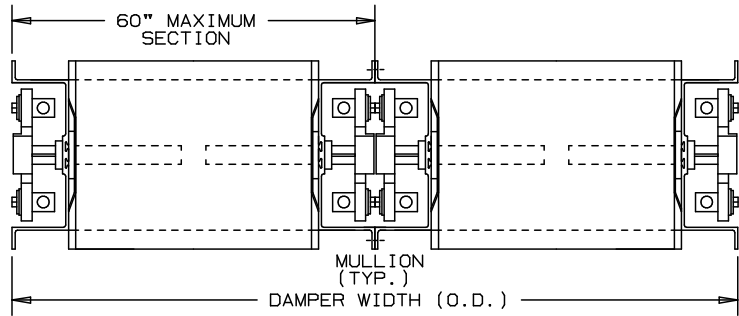

SPECIFICATIONS

- FRAME:** 5" WIDE, 6063T6/T52 EXTRUDED ALUMINUM "HAT-SHAPED" CHANNEL, .080" NOMINAL, .125" OPTIONAL WALL THICKNESS.
- BLADE:** 6" WIDE, 6063-T6/T52 EXTRUDED ALUMINUM .080" NOMINAL WALL THICKNESS. AIRFOIL PROFILE INJECTED WITH A TWO PART POLYURETHANE (CFC) FREE FOAM, AND DEBRIDGED FOR THERMAL ISOLATION.
- AXLE:** 1/2" DIAMETER EXTRUDED ALUMINUM "PIN-LOCK" DESIGN, INTERLOCKING INTO BLADE SECTION.
- LINKAGE:** CONCEALED IN JAMB OF HEAVY ALUMINUM. CRANK ARM PERMANENTLY LOCKED TO BLADE AXLE BY TWO STAINLESS STEEL FASTENERS. THE CRANK ARM CONTAINS A 1/2" DIAMETER METAL PIVOT RIDING IN A CELCON BEARING. A 1/4"-20 SET SCREW WITH LOCKING PATCH TIES THE 5/16" DIAMETER ALUMINUM LINKAGE ROD. THE LINKAGE OF EACH DAMPER IS INDIVIDUALLY ADJUSTED.
- BEARINGS:** "DOUBLE-SEALED" TYPE WITH CELCON INNER BEARING RIDING INSIDE A POLYCARBONATE OUTER BEARING POSITIVELY LOCKED INTO FRAME, DESIGNED SO THAT THERE SHALL BE NO METAL-TO-METAL OR METAL-TO-BEARING RIDING SURFACES.
- SEALS:** EXTREME LOW TEMPERATURE SEAL SYSTEM, EXTRUDED SILICONE RUBBER BLADE EDGE SEAL THAT FITS INTO A RIBBED GROOVE INSERT IN BLADES WITH AN EXTRUDED POLYCARBONATE SEAL AT JAMBS.
- TEMPERATURE RATINGS:** -40°F TO +200°F, AFDTI-25
- FINISH:** MILL.

MODEL AFDTI-25

- SIZES:** MADE TO EXACT SIZES AS REQUESTED.
- MINIMUM PANEL SIZE - 6" x 8 7/8" SINGLE BLADE
- MAXIMUM PANEL SIZE - 60" x 72" PARALLEL/OPPOSED

FOR DAMPER PERFORMANCE
- SEE REVERSE SIDE

NOMINAL DEDUCTIONS WILL BE MADE TO THE OPENING SIZE GIVEN.

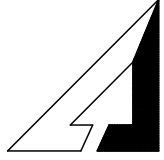
ITEM	QTY.	WIDTH	HEIGHT	PAR.	OPP.	ACTUATOR MODEL	INT.	EXT.	N.C.	N.O.	TAGGING	
		DAMPER SIZE (O.D.)					LOCATION	FUNCTION				
 ARROW UNITED INDUSTRIES A DIVISION OF MESTEK, INC. 450 RIVERSIDE DRIVE WYALUSING, PA 18853 TEL: (570) 746-1888 FAX: (570) 746-9286 WEB ADDRESS: WWW.ARROWUNITED.COM							ARCH./ENG.:					
AGENT: _____							CONTR.:					
							PROJECT:					
							EDR:		ECN:		JOB:	
							DATE:		DWN.:		DWG.:	

DAMPER MODEL AFDTI-25

EXTRUDED ALUMINUM - PARALLEL - OPPOSED

PERFORMANCE DATA

MODEL AFDTI-25 DAMPER SIZE 36" x 36"

PRESSURE DROP RATINGS ARE BASED ON AMCA STANDARD 500-D-97 USING TEST SET-UP FIG. 5.3 FOR DAMPER INSTALLED WITH DUCT UPSTREAM AND DOWNSTREAM. STATIC PRESSURES ARE CORRECTED TO .075 LB/CU FT AIR DENSITY.

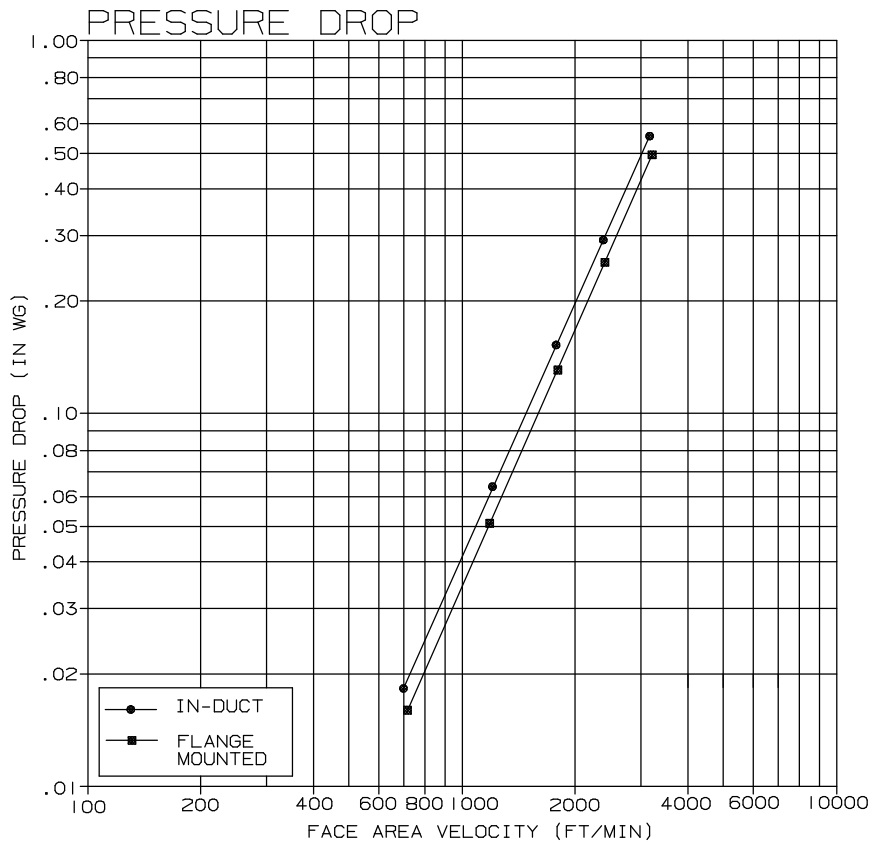

DAMPER MODEL AFDTI-25

EXTRUDED ALUMINUM - PARALLEL - OPPOSED

PERFORMANCE DATA

LEAKAGE

TOTAL CFM LEAKAGE AT 1" W.G.
STATIC PRESSURE DIFFERENTIAL

DAMPER HEIGHT (INCHES)	DAMPER WIDTH (INCHES)				
	12"	24"	36"	48"	60"
12"	2	4	6	8	10
18"	3	6	9	12	15
24"	4	8	12	16	20
30"	5	10	15	20	25
36"	6	12	18	24	30
42"	7	14	21	28	35
48"	8	16	24	32	40
54"	9	18	27	36	45
60"	10	20	30	40	50
66"	11	22	33	44	55
72"	12	24	36	48	60

LEAKAGE RATINGS ARE BASED ON AMCA STANDARD 500-D-97 USING TEST SET-UP FIG. 5.4. DATA IS BASED ON A CLOSING TORQUE OF 5 IN-LB/SQ.FT. FOR DAMPERS LESS THAN 6 SQ. FT. HAVING A CLOSING TORQUE OF 40 IN-LB. DAMPER CLOSING TORQUE IS APPLIED TO DAMPER OPERATING SHAFT.

LEAKAGE CORRECTION FACTOR

DAMPER WIDTH (INCHES)	STATIC PRESSURE (INCHES WATER GAUGE)						
	2"	3"	4"	5"	6"	7"	8"
12"-60"	1.44	1.64	2.00	2.22	2.44	2.64	2.82

USE OF CORRECTION FACTORS WILL GIVE LEAKAGE VALUES AT GREATER THAN 1" PRESSURES

AFDTI-25 DAMPER LIMITATIONS

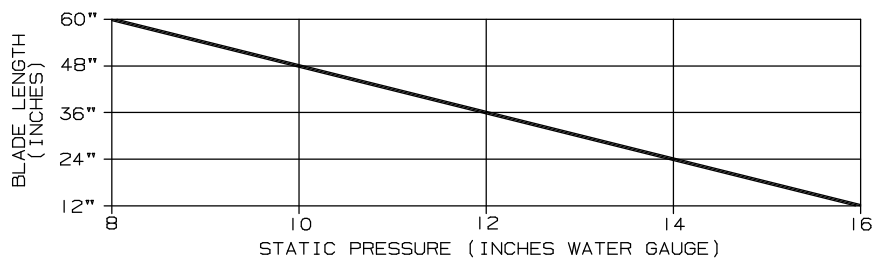

MODEL AFDTI-25 DAMPER DESIGN AT REDUCED LENGTHS CAN WITHSTAND HIGHER STATIC PRESSURE LIMITS WITHOUT SACRIFICING DAMPER OPERATION AND PERFORMANCE. STATIC PRESSURES ABOVE 8" W.G. WILL AFFECT OPERATION TORQUE VALUE.

DAMPER MODEL AFDTI-25 EXTRUDED ALUMINUM - PARALLEL - OPPOSED PERFORMANCE DATA

ARROW MODEL AFDTI-25 THERMAL PERFORMANCE

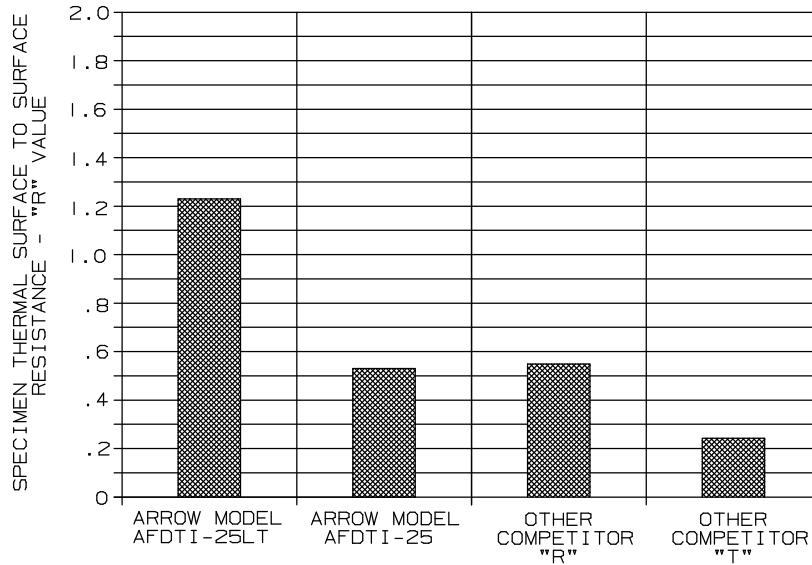

DAMPER ASSEMBLY THERMAL PERFORMANCE RATING TESTED TO ASTM C-1363-97, STANDARD TEST METHOD FOR THERMAL PERFORMANCE OF BUILDING ASSEMBLIES BY MEANS OF A HOT BOX APPARATUS AND (REPLACES C-236 AND C-976 TEST METHODS).