

# Damper Operation Test Box

Models: Optional For All Combination Fire/ Smoke and Smoke Damper Models

## APPLICATION

Per NFPA 80 and 105, "Each damper shall be tested and inspected one year after installation. The test and inspection frequency shall be every 4 years, except in hospitals, where the frequency shall be every 6 years.

Prior to the inception of these remote damper operation testing features, our fire/smoke dampers could be cycled by manually tripping the heat response device or by pressing the test button on the smoke detector. These methods required that you disconnected power and remove access panels to reset the heat response device or that you gain access to the smoke detector interface, which is quite often not in an easily accessible location once the damper is installed.

Our optional remote operation testing features enable you to cycle test the damper via a remote test station, which can be ordered in a variety of configurations to fit your application. Although visual inspection and maintenance are still required, position indicator switches can be incorporated into these testing features to enable remote monitoring of blade location.

### Momentary Push Button Test Box

The Momentary Push Button Test Box will permit momentary interruption of power to the fire/smoke or smoke damper. As long as the spring-loaded toggle is depressed, power is disconnected and the damper will travel to its fail position. A position indication package **is not required** with this feature.

Factory Mounted

Shipped Loose

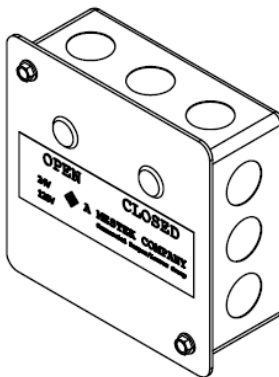
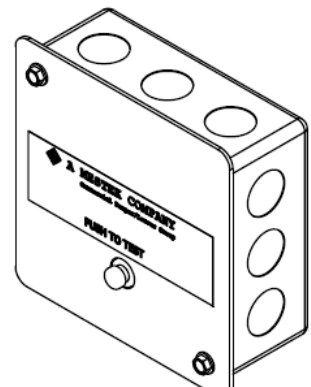

### Lights Only Position Indication Test Box

The Lights Only Test Box will permit remote open and closed blade position indication of the fire/smoke or smoke damper. A position indication package **is required** with this feature.

Factory Mounted

Shipped Loose

24 VAC/DC

120 VAC

### Test Boxes with Position Indications

Test Boxes with position indication will permit interruption of power to the fire/smoke or smoke damper and permit remote open and close blade position indication. As long as the momentary switch is depressed or toggle switch is toggled to the "power off" position (toggle switches are not spring-return type), power is disconnected and the damper will travel to its fail position. When the damper reaches its full open position a green LED will illuminate, when the damper reaches its full closed positional red/amber LED will illuminate. A position indication package **is required** with these features.

2- Position Push-Button Momentary

2- Position Momentary Toggle (shown)

3- Position Toggle (only available w/ ESOT or PSOT)

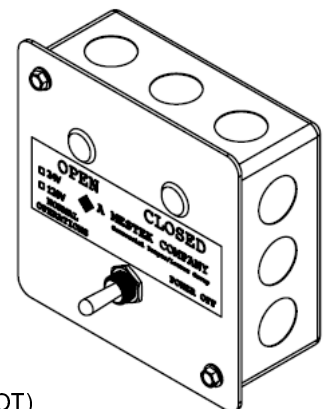

Factory Mounted

Shipped Loose

24 VAC/DC

120 VAC

Models: Optional For All Combination Fire/ Smoke and Smoke Damper Models

### **Description:**

The Test Box consists of a 4" wide x 4" high x 2-1/4" deep steel box with multiple conduit knockouts. The steel cover is mounted and labeled for the appropriate configuration that has been selected.

### **Factory Mount vs. Ship Loose:**

Factory mounted test boxes will ship with the 4" x 4" test box connected and wired to the master actuator with a 3' x Ø3/8" flexible galvanized conduit whip (or whips, if necessary). Although the box is pre-wired and complete with conduit and fittings, the test box itself will not be secured to the damper such that the installer can fasten the box in the location best suited to each installation. Consult the factory if your application requires a whip that is longer than 3'. The voltage of the test box will match the voltage of the actuator that is selected with the damper.

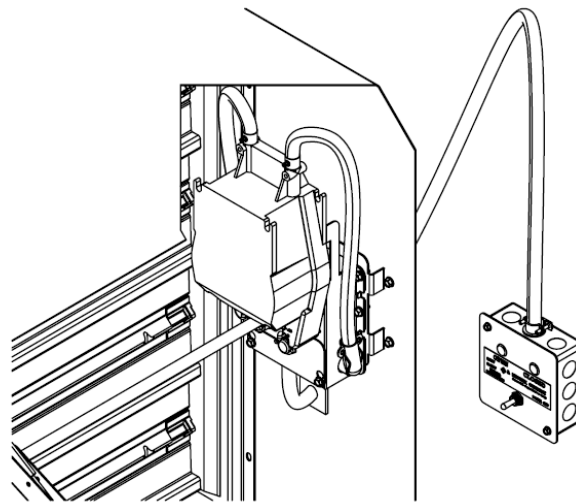

Ship loose test boxes will only ship with the 4" x 4" test box assembled with the applicable combination of a switch and/or lights mounted on a cover plate. All additional wires, conduit, fittings, and hardware are by others. When ordering ship loose, you must specify the required voltage (24v or 120v). The following schematic represent factory wiring scenarios, field conditions may require variations of these suggested circuits.

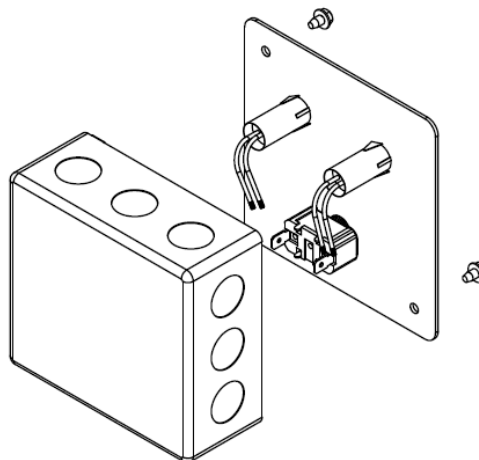

Models: Optional For All Combination Fire/ Smoke and Smoke Damper Models

## Schematics

### Factory wiring for 2-pos Momentary Test

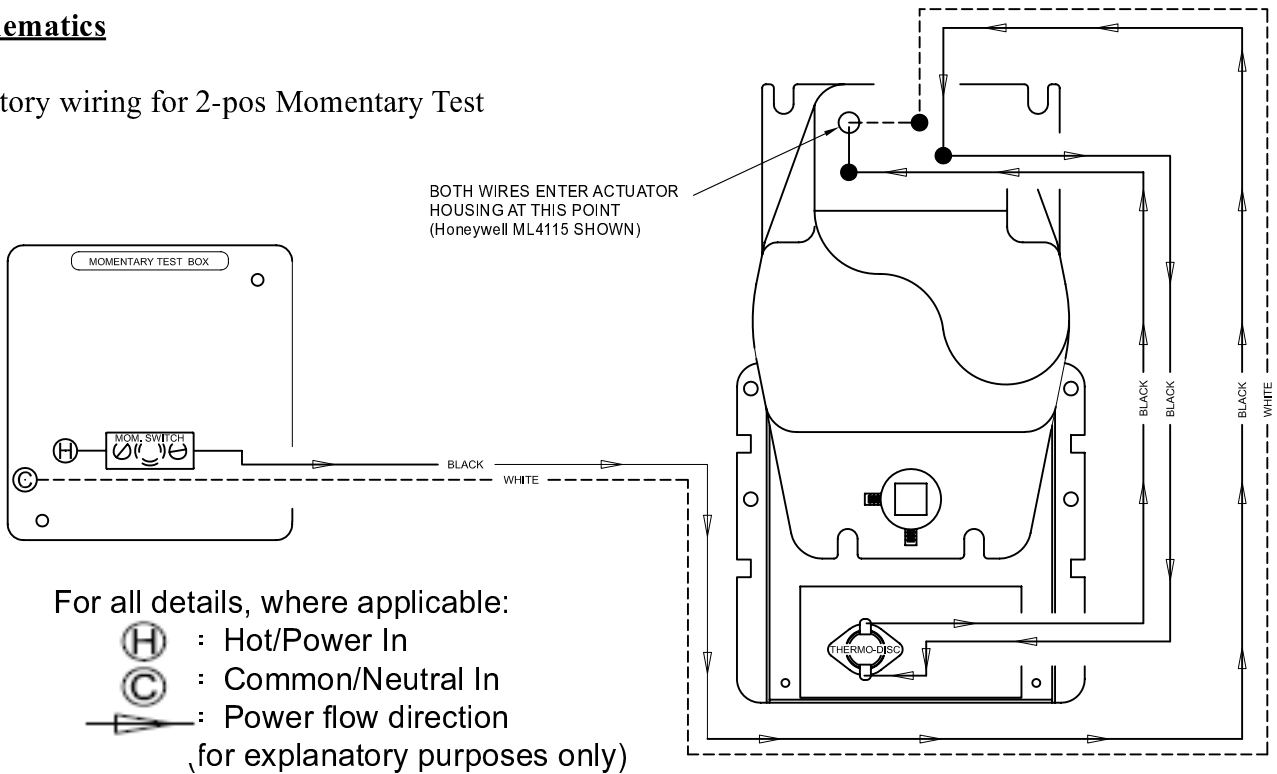

Note - Thermo-disc not part of smoke damper circuit

### Factory wiring for 2-Pos Momentary (or Toggle) with Position Indication

Shown with auxiliary switch package;  
 damper in closed position with red/amber LED illuminated

see page 4, Wiring Chart for additional  
 switch package wiring details

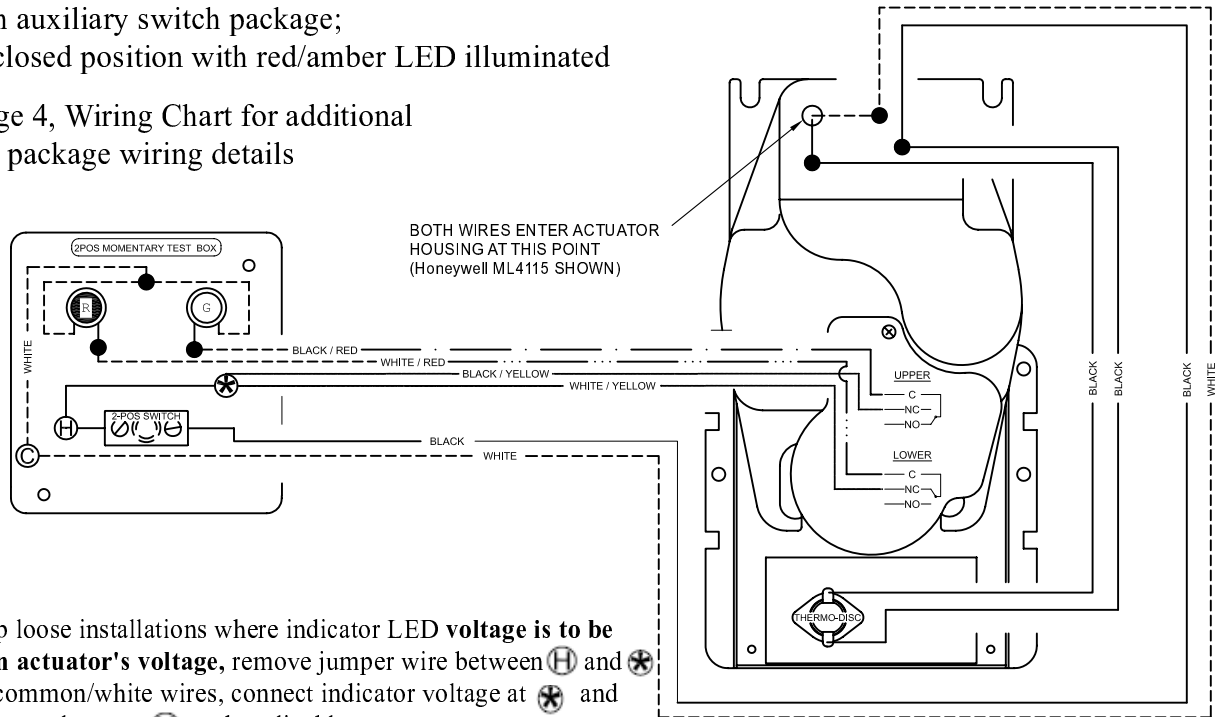

Models: Optional For All Combination Fire/ Smoke and Smoke Damper Models

## Factory wiring for 3-Pos Toggle with Position Indication (used only on fire/smoke damper with ESOT)

\* Note - It is intended that an additional power lead be connected to the orange 're-open' lead such that remote opening of the damper can happen from location other than this remote test box, such as a fire control or building management system.

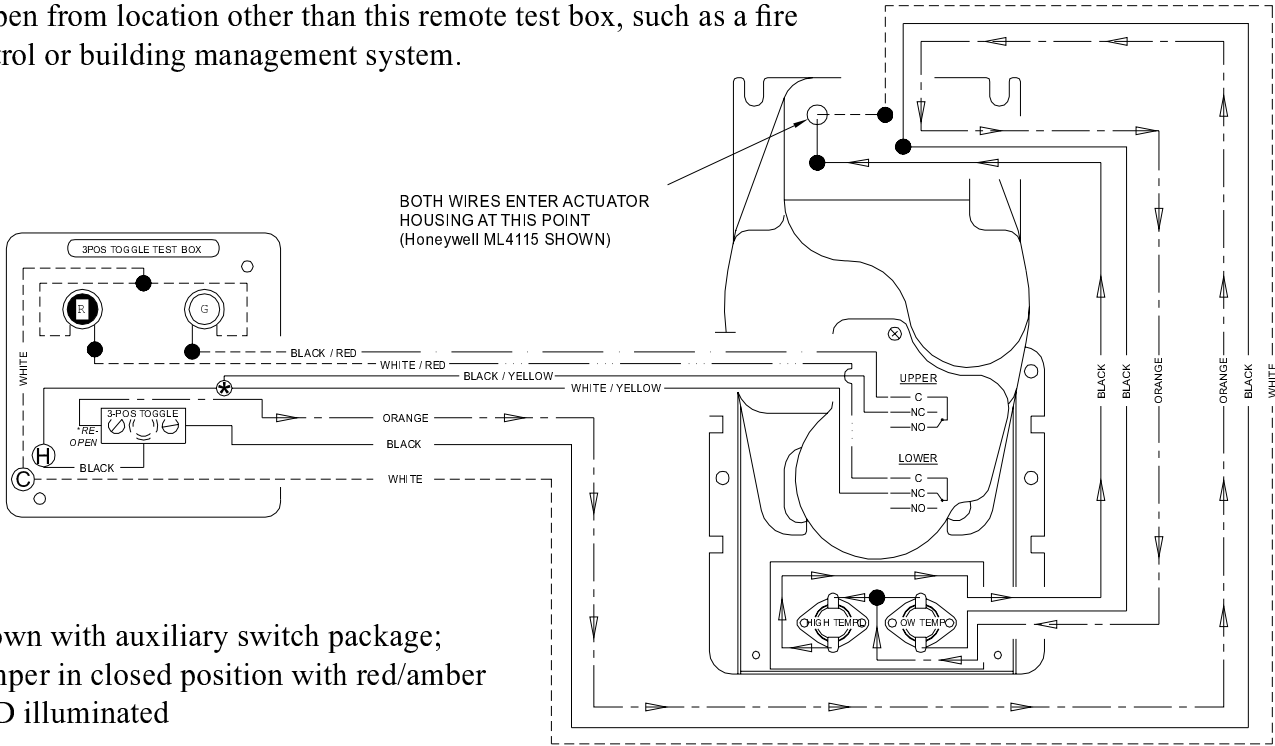

Shown with auxiliary switch package;  
damper in closed position with red/amber  
LED illuminated

For all details, where applicable:

- = Hot/Power In
  - = Common/Neutral In
  - = Power flow direction
- (for explanatory purposes only)

Note - for ship loose installations where indicator LED voltage is to be **different than actuator's voltage**, remove jumper wire between and and between common/white wires, connect indicator voltage at , and connect actuator voltage at , and applicable common to common.

| POSITION INDICATION SWITCH PACKAGE WIRING CHART |                          |                         |                        |                         |
|---|--------------------------|-------------------------|------------------------|-------------------------|
|   | CLOSED DAMPER INDICATION |                         | OPEN DAMPER INDICATION |                         |
|   | LOWER LIMIT COMMON       | NORMALLY CLOSED (LOWER) | UPPER LIMIT COMMON     | NORMALLY CLOSED (UPPER) |
| PK1200-1201 PACKAGE                             | RED                      | BLUE                    | GRAY                   | ORANGE                  |
| BELIMO FSLF                                     | S1                       | S2                      | S4                     | S6                      |
| BELIMO FSNF                                     | S1                       | S2                      | S4                     | S5                      |
| BELIMO FSAFB24-SR-S                             | S1                       | S2                      | S4                     | S5                      |
| HONEYWELL AUXILIARY                             | WHITE/RED                | WHITE/YELLOW            | BLACK/RED              | BLACK/YELLOW            |
| HONEYWELL 4104F/4120F SERIES                    | BLUE                     | BLUE                    | YELLOW                 | YELLOW                  |

# Damper Operation Test Box

Models: Optional For All Combination Fire/ Smoke and Smoke Damper Models

### Factory wiring for 2-Pos Momentary or Toggle with Position Indicator and Smoke Detector

see page 4, Wiring Chart for additional switch package wiring details

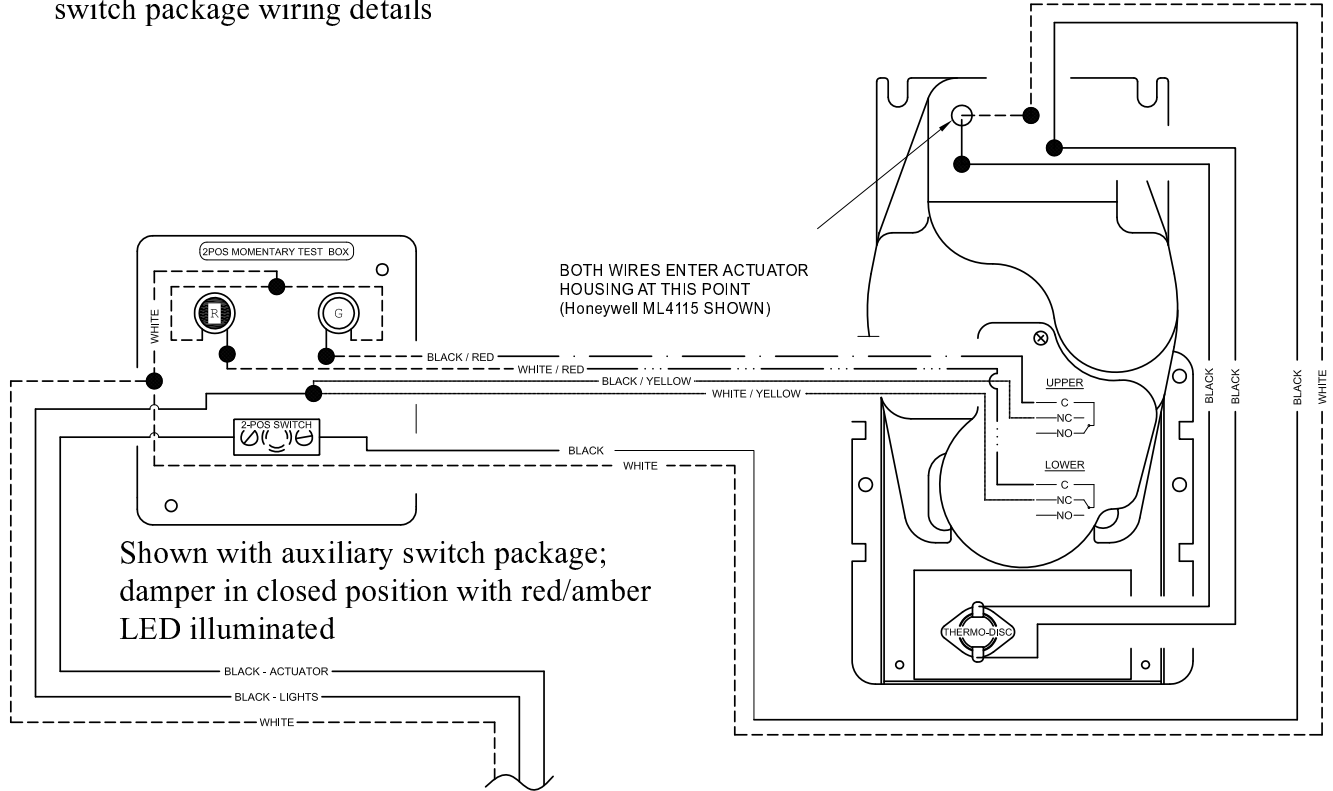

- Ⓜ = Hot/Power In
- ⓐ = Common/Neutral In

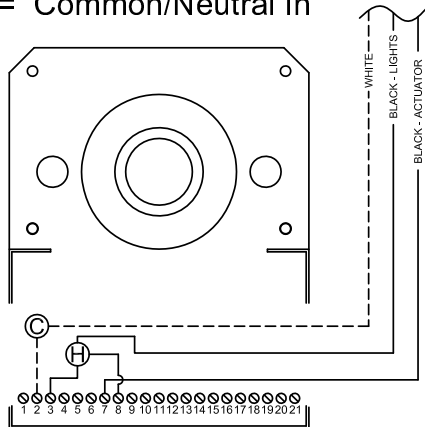

**SM-501-P SMOKE DETECTOR**  
 (120v wiring shown, refer to smoke detector installation instructions for 24v installations)

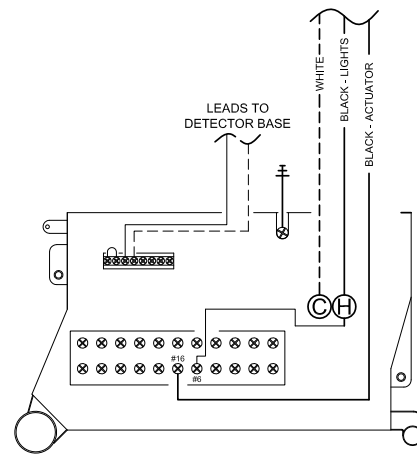

**2D51 SMOKE DETECTOR**  
 (120v wiring shown, refer to smoke detector installation instructions for 24v installations)

Models: Optional For All Combination Fire/ Smoke and Smoke Damper Models

## Factory wiring for 3-Pos Toggle with Position Indicator and Smoke Detector (use only on fire/smoke damper with ESOT)

\* Note - It is intended that an additional power lead be connected to the orange 're-open' lead such that remote opening of the damper can happen from location other than this remote test box, such as a fire control or building management system.

see page 4, Wiring Chart for additional switch package wiring details

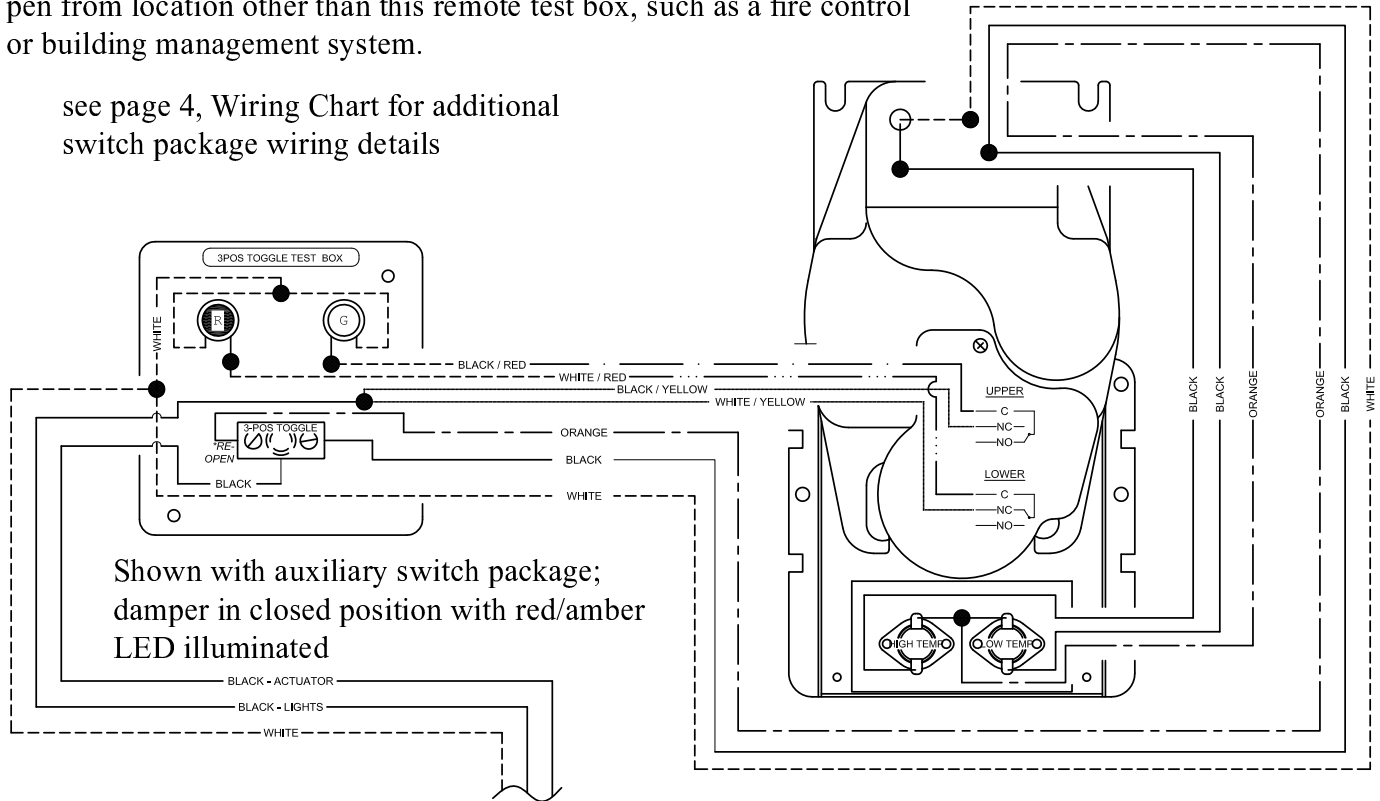

- Ⓜ = Hot/Power In
- Ⓒ = Common/Neutral In

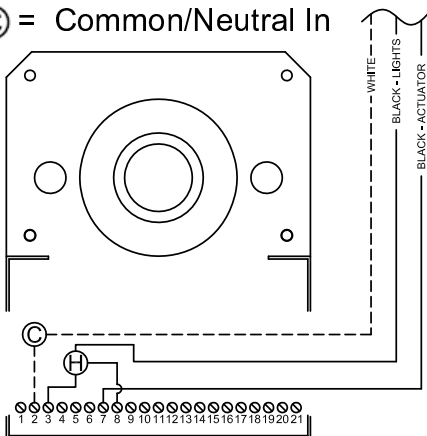

**SM-501-P SMOKE DETECTOR**  
(120v wiring shown, refer to smoke detector installation instructions for 24v installations)

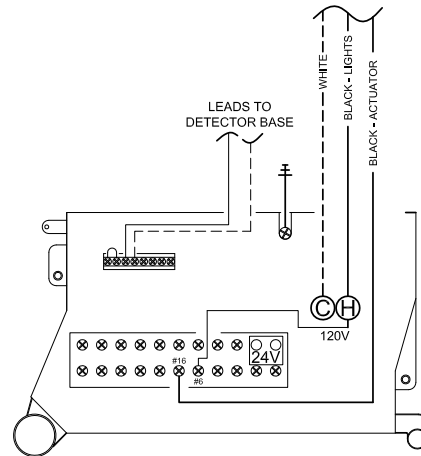

**2D51 SMOKE DETECTOR**  
(120v wiring shown, refer to smoke detector installation instructions for 24v installations)