

# Indirect Fired Heating Systems

Technical Guide for:

- **IF** Indoor Installations
- **IFW** Outdoor Installations

Applied Air

Keeps You

Warm



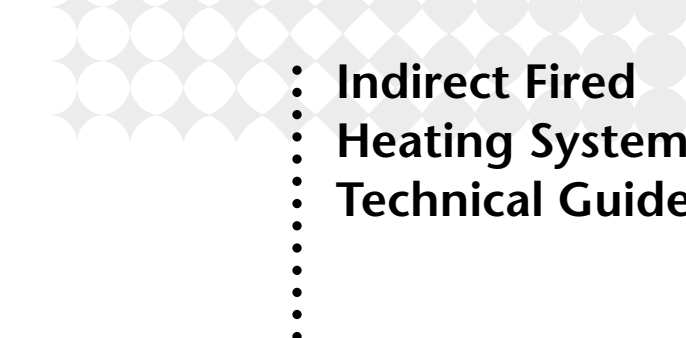

**Indirect Fired  
Heating Systems  
Technical Guide**



**Applied Air**

In the business of industrial heating, efficient and low-cost operation is essential. Applied Air keeps you warm for less.

Since 1975, Applied Air has been providing cost-effective, reliable heating solutions. Our proven Indirect Fired Heating Systems adds warm clean air to your work environment, but without the products of combustion in the airstream.

This Technical Guide will help you choose an Applied Air Indirect Fired Gas Heating System to provide efficient, cost-effective heating and ventilation for your facility. The Guide covers:

- Technical Specifications — Configure the right system components (e.g., motors, drive, filter, options, etc.) to meet your needs.
  - Model “IF” for indoor installations
  - Model “IFW” for outdoor installations
- Installation Information — Plan details of on-site installation (dimensions, gas piping, etc.).

If you have questions, please contact Applied Air’s Customer Service Department at 214-638-6010. We’ll be glad to help.

**Applied Air**

**Keeps You**

**Warm**



# Applied Air

Unit Arrangements .....	4
Air Delivery Tables .....	5-9
Engineering Data .....	10-11
<b>Dimensions</b>	
Standard Vertical Units .....	12
Standard Horizontal Units .....	13
Side Mount Filter and Filter/Mixing Box .....	14
Base Mount Filter and Filter/Mixing Box .....	15
Dampers .....	16
Service Platform .....	17
Discharge Nozzles .....	17
Intake Hoods .....	18
Amp Draw Table .....	19
Typical Gas Piping Layout .....	20
Guide Specification .....	21-22

# Basic Types of Units

## Models IF, IFW Schematic Component Diagrams

C000514

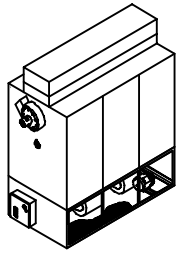

Style V floor-mounted vertical unit for duct installation.

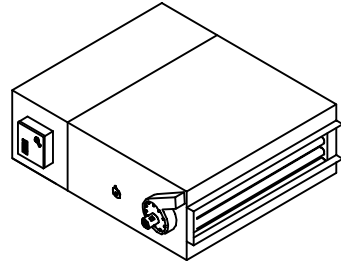

Style H indoor horizontal suspended unit for duct installation.

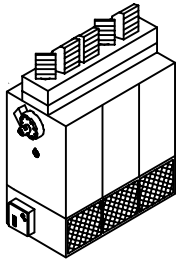

Style VH indoor floor-mounted with optional adjustable discharge nozzles and screened inlets.

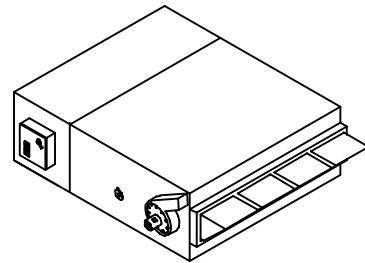

Style HH indoor horizontal suspended unit with optional discharge nozzles.

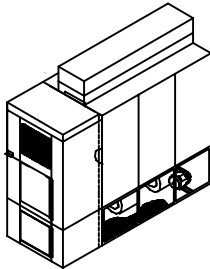

Style VW outdoor pad mounted vertical unit for duct installation.

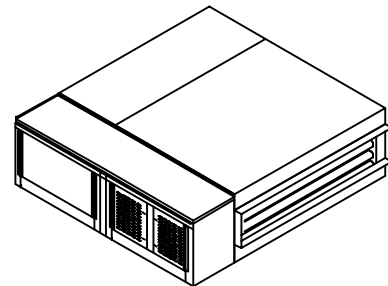

Style HW outdoor pad mounted horizontal unit for duct installation.

- (A) The Applied Air IF Series is available in a complete range of sizes from 350,000 to 6,000,000 BTU output. IF units are assembled, wired and flame-tested before shipment.
- (B) Accessories such as filters banks, dampers, service platforms, discharge heads, vibration feet and hangers are available as optional items for special applications or installations. Power driven exhausters are standard equipment on all models.

# Air Delivery Table

Models IF & IFW										
Model	Blowers	SCFM	Total External Static Pressure (W.C.)							
			1/4"	1/2"	3/4"	1"	1 1/4"	1 1/2"	1 3/4"	2"
			HP	HP	HP	HP	HP	HP	HP	HP
35-40	(2) 12" x 9"	3500	1 1/2	1 1/2	2	—	—	—	—	—
		4000	1 1/2	2	3	3	—	—	—	—
		4500	2	3	3	3	5	—	—	—
		5000	3	3	3	5	5	5	—	—
		5500	3	3	5	5	5	5	5	5
55/35-40	(2) 12" x 12"	5000	2	2	3	3	—	—	—	—
		5500	2	2	3	3	5	—	—	—
		6000	3	3	5	5	5	5	—	—
		6500	3	5	5	5	5	5	5	—
		7000	5	5	5	5	—	—	—	—
75/35-40	(2) 15" x 15"	7000	2	3	3	—	—	—	—	—
		7500	3	3	5	5	—	—	—	—
		8000	3	5	5	5	—	—	—	—
		8500	5	5	5	5	7 1/2	—	—	—
		9000	5	5	5	7 1/2	7 1/2	10	—	—
		9500	5	5	7 1/2	7 1/2	7 1/2	10	—	—
		10,000	5	7 1/2	7 1/2	7 1/2	7 1/2	10	10	—
45-55	(2) 12" x 12"	5000	2	2	3	3	—	—	—	—
		5500	2	2	3	3	5	—	—	—
		6000	3	3	5	5	5	5	—	—
		6500	3	5	5	5	5	5	5	—
		7000	5	5	5	5	—	—	—	—
75/45-55	(2) 15" x 15"	7000	2	3	3	—	—	—	—	—
		7500	3	3	5	5	—	—	—	—
		8000	3	5	5	5	—	—	—	—
		8500	5	5	5	5	7 1/2	—	—	—
		9000	5	5	5	7 1/2	7 1/2	10	—	—
		9500	5	5	7 1/2	7 1/2	7 1/2	10	—	—
		10,000	5	7 1/2	7 1/2	7 1/2	7 1/2	10	10	—
100/45-55	(2) 18" x 18"	9000	3	5	5	5	—	—	—	—
		9500	3	5	5	5	—	—	—	—
		10,000	3	5	5	5	—	—	—	—
		10,500	5	5	5	7 1/2	7 1/2	—	—	—
		11,000	5	5	7 1/2	7 1/2	7 1/2	—	—	—
		11,500	5	7 1/2	7 1/2	7 1/2	7 1/2	10	—	—
		12,000	5	7 1/2	7 1/2	10	10	10	10	—
		12,500	7 1/2	7 1/2	7 1/2	10	10	10	10	—
		13,000	7 1/2	7 1/2	10	10	10	10	—	—
65-75	(2) 15" x 15"	7000	2	3	3	—	—	—	—	—
		7500	3	3	5	5	—	—	—	—
		8000	3	5	5	5	—	—	—	—
		8500	5	5	5	5	7 1/2	—	—	—
		9000	5	5	5	7 1/2	7 1/2	10	—	—
		9500	5	5	7 1/2	7 1/2	7 1/2	10	—	—
		10,000	5	7 1/2	7 1/2	7 1/2	7 1/2	10	10	—

**NOTES:**

- Horsepower selections are based on system external static pressure. To determine total external static pressure, add all applicable accessory pressure drops listed below:
  - A. Fresh Air Inlet Hood & Birdscreen 0.13" W.C.
  - B. Motor Operated Dampers 0.13" W.C.
  - C. V-Bank Filter Section 0.25" W.C.
  - D. Discharge Nozzles 0.25" W.C.
- Select unit size and motor horsepower from table above.
- Contact factory for applications not shown.

**EXPLANATION OF MODEL NUMBERS**

**DASH MODEL NUMBERS** - A dash in the model number indicates the BTU range on the heat exchanger. Example: Model 35-40 has a heat exchanger rating of 350,000-400,000 BTU output.

**SLASH MODEL NUMBERS** - A slash in the model number indicates the use of a larger blower section with a smaller heat exchanger, normally used for low temperature rise applications. Example: Model 75/35-40 has a 75 size blower section, which offers airflow up to 10,000 CFM, with a heat exchanger rating of 350,000-400,000 BTU output.

# Air Delivery Table

Models IF & IFW			Total External Static Pressure (W.C.)							
Model	Blowers	SCFM	1/4"	1/2"	3/4"	1"	1 1/4"	1 1/2"	1 3/4"	2"
			HP	HP	HP	HP	HP	HP	HP	HP
100/65-75	(2) 18" x 18"	9000	3	5	5	5	—	—	—	—
		9500	3	5	5	5	—	—	—	—
		10,000	3	5	5	5	—	—	—	—
		10,500	5	5	5	7 1/2	7 1/2	—	—	—
		11,000	5	5	7 1/2	7 1/2	7 1/2	—	—	—
		11,500	5	7 1/2	7 1/2	7 1/2	7 1/2	10	—	—
		12,000	5	7 1/2	7 1/2	10	10	10	10	—
		12,500	7 1/2	7 1/2	7 1/2	10	10	10	10	—
		13,000	7 1/2	7 1/2	10	10	10	10	—	—
175/65-75	(3) 18" x 13"	13,000	5	5	7 1/2	7 1/2	7 1/2	—	—	—
		14,000	7 1/2	7 1/2	7 1/2	7 1/2	7 1/2	—	—	—
		15,000	7 1/2	7 1/2	10	10	10	10	—	—
		16,000	7 1/2	10	10	10	10	15	15	15
		17,000	10	10	10	15	15	15	15	15
		18,000	10	15	15	15	15	15	15	20
		19,000	10	15	15	15	15	15	20	20
		20,000	15	15	15	15	20	20	20	20
		21,000	15	15	20	20	20	20	20	25
		23,000	20	20	20	25	25	25	25	25
85-100	(2) 18" x 18"	9000	3	5	5	5	—	—	—	—
		9500	3	5	5	5	—	—	—	—
		10,000	3	5	5	5	—	—	—	—
		10,500	5	5	5	7 1/2	7 1/2	—	—	—
		11,000	5	5	7 1/2	7 1/2	7 1/2	—	—	—
		11,500	5	7 1/2	7 1/2	7 1/2	7 1/2	10	—	—
		12,000	5	7 1/2	7 1/2	10	10	10	10	—
		12,500	7 1/2	7 1/2	7 1/2	10	10	10	10	—
		13,000	7 1/2	7 1/2	10	10	10	10	—	—
175/85-100	(3) 18" x 13"	13,000	5	5	7 1/2	7 1/2	7 1/2	—	—	—
		14,000	7 1/2	7 1/2	7 1/2	7 1/2	7 1/2	—	—	—
		15,000	7 1/2	7 1/2	10	10	10	10	—	—
		16,000	7 1/2	10	10	10	10	15	15	15
		17,000	10	10	10	15	15	15	15	15
		18,000	10	15	15	15	15	15	15	20
		19,000	10	15	15	15	15	15	20	20
		20,000	15	15	15	15	20	20	20	20
		21,000	15	15	20	20	20	20	20	25
		23,000	20	20	20	25	25	25	25	25
250/85-100	(3) 18" x 18"	21,000	10	15	15	15	20	20	20	20
		23,000	15	15	15	20	20	20	20	25
		25,000	15	20	20	20	25	25	25	25
		27,000	20	20	25	25	25	30	30	30
		29,000	25	25	30	30	30	40	40	40
		31,000	30	30	40	40	40	40	40	40
		33,000	40	40	40	40	40	40	—	—

**NOTES:**

- Horsepower selections are based on system external static pressure. To determine total external static pressure, add all applicable accessory pressure drops listed below:
  - A. Fresh Air Inlet Hood & Birdscreen 0.13" W.C.
  - B. Motor Operated Dampers 0.13" W.C.
  - C. V-Bank Filter Section 0.25" W.C.
  - D. Discharge Nozzles 0.25" W.C.
- Select unit size and motor horsepower from table above.
- Contact factory for applications not shown.

**EXPLANATION OF MODEL NUMBERS**

**DASH MODEL NUMBERS** - A dash in the model number indicates the BTU range on the heat exchanger. Example: Model 35-40 has a heat exchanger rating of 350,000-400,000 BTU output.

**SLASH MODEL NUMBERS** - A slash in the model number indicates the use of a larger blower section with a smaller heat exchanger, normally used for low temperature rise applications. Example: Model 75/35-40 has a 75 size blower section, which offers airflow up to 10,000 CFM, with a heat exchanger rating of 350,000-400,000 BTU output.

# Air Delivery Table

Models IF & IFW										
Model	Blowers	SCFM	Total External Static Pressure (W.C.)							
			1/4"	1/2"	3/4"	1"	1 1/4"	1 1/2"	1 3/4"	2"
			HP	HP	HP	HP	HP	HP	HP	HP
125-175	(3) 18" x 13"	13,000	5	5	7 1/2	7 1/2	7 1/2	—	—	—
		14,000	7 1/2	7 1/2	7 1/2	7 1/2	7 1/2	—	—	—
		15,000	7 1/2	7 1/2	10	10	10	10	—	—
		16,000	7 1/2	10	10	10	10	15	15	15
		17,000	10	10	10	15	15	15	15	15
		18,000	10	15	15	15	15	15	15	20
		19,000	10	15	15	15	15	15	20	20
		20,000	15	15	15	15	20	20	20	20
		21,000	15	15	20	20	20	20	20	25
		23,000	20	20	20	25	25	25	25	25
250/125-175	(3) 18" x 18"	21,000	10	15	15	15	20	20	20	20
		23,000	15	15	15	20	20	20	20	25
		25,000	15	20	20	20	25	25	25	25
		27,000	20	20	25	25	25	30	30	30
		29,000	25	25	30	30	30	40	40	40
		31,000	30	30	40	40	40	40	40	40
		33,000	40	40	40	40	40	40	—	—
300/125-175	(3) 20" x 20"	29,000	15	15	20	20	25	25	25	25
		31,000	20	20	20	25	25	25	25	30
		33,000	20	20	25	25	25	30	30	30
		35,000	20	25	25	25	30	30	40	40
		37,000	25	30	30	30	40	40	40	50
		39,000	30	30	30	40	40	40	—	—
200-250	(3) 18" x 18"	21,000	10	15	15	15	20	20	20	20
		23,000	15	15	15	20	20	20	20	25
		25,000	15	20	20	20	25	25	25	25
		27,000	20	20	25	25	25	30	30	30
		29,000	25	25	30	30	30	40	40	40
		31,000	30	30	40	40	40	40	40	40
		33,000	40	40	40	40	40	40	—	—
300/200-250	(3) 20" x 20"	29,000	15	15	20	20	25	25	25	25
		31,000	20	20	20	25	25	25	25	30
		33,000	20	20	25	25	25	30	30	30
		35,000	20	25	25	25	30	30	40	40
		37,000	25	30	30	30	40	40	40	50
		39,000	30	30	30	40	40	40	—	—
400/200-250	(3) 22" x 22"	35,000	20	20	20	25	25	25	30	30
		37,000	20	20	25	25	30	30	30	40
		39,000	20	25	25	30	30	30	40	40
		41,000	25	25	30	30	40	40	40	40
		43,000	30	30	30	40	40	40	40	50
		45,000	30	40	40	40	40	50	50	50
		47,000	40	40	40	40	50	50	50	50
		49,000	40	40	50	50	50	50	60	60
		51,000	50	50	50	50	60	60	60	60
		53,000	50	50	60	60	60	75	75	75

**NOTES:**

1. Horsepower selections are based on system external static pressure. To determine total external static pressure, add all applicable accessory pressure drops listed below:
 

A. Fresh Air Inlet Hood & Birdscreen	0.13" W.C.	C. V-Bank Filter Section	0.25" W.C.
B. Motor Operated Dampers	0.13" W.C.	D. Discharge Nozzles	0.25" W.C.
2. Select unit size and motor horsepower from table above.
3. Contact factory for applications not shown.

**EXPLANATION OF MODEL NUMBERS**

**DASH MODEL NUMBERS** - A dash in the model number indicates the BTU range on the heat exchanger. Example: Model 35-40 has a heat exchanger rating of 350,000-400,000 BTU output.

**SLASH MODEL NUMBERS** - A slash in the model number indicates the use of a larger blower section with a smaller heat exchanger, normally used for low temperature rise applications. Example: Model 75/35-40 has a 75 size blower section, which offers airflow up to 10,000 CFM, with a heat exchanger rating of 350,000-400,000 BTU output.

# Air Delivery Table

Models IF & IFW											
Model	Blowers	SCFM	Total External Static Pressure (W.C.)								
			1/4"	1/2"	3/4"	1"	1 1/4"	1 1/2"	1 3/4"	2"	
			HP	HP	HP	HP	HP	HP	HP	HP	
275-300	(3) 20" x 20"	29,000	15	15	20	20	25	25	25	25	25
		31,000	20	20	20	25	25	25	25	25	30
		33,000	20	20	25	25	25	30	30	30	30
		35,000	20	25	25	25	30	30	40	40	40
		37,000	25	30	30	30	40	40	40	40	50
		39,000	30	30	30	40	40	40	—	—	—
400/275-300	(3) 22" x 22"	35,000	20	20	20	25	25	25	30	30	30
		37,000	20	20	25	25	30	30	30	40	40
		39,000	20	25	25	30	30	30	40	40	40
		41,000	25	25	30	30	40	40	40	40	40
		43,000	30	30	30	40	40	40	40	40	50
		45,000	30	40	40	40	40	50	50	50	50
		47,000	40	40	40	40	50	50	50	50	50
		49,000	40	40	50	50	50	50	60	60	60
		51,000	50	50	50	50	60	60	60	60	60
		53,000	50	50	60	60	60	75	75	75	75
600/275-300	(3) 27 1/2" x 27 1/2"	55,000	25	25	30	30	40	40	—	—	—
		58,000	25	30	40	40	40	40	—	—	—
		61,000	30	40	40	40	50	50	—	—	—
		64,000	30	40	40	50	50	50	50	—	—
		67,000	40	50	50	50	50	60	60	60	60
		70,000	40	50	50	60	60	60	60	60	60
		73,000	50	50	60	60	75	75	75	75	75
		76,000	50	60	60	60	75	75	75	75	75
		79,000	60	75	75	75	75	75	75	75	—
		81,000	60	75	75	75	75	75	—	—	—
325-400	3) 22" x 22"	35,000	20	20	20	25	25	25	30	30	30
		37,000	20	20	25	25	30	30	30	30	40
		39,000	20	25	25	30	30	30	40	40	40
		41,000	25	25	30	30	40	40	40	40	40
		43,000	30	30	30	40	40	40	40	40	50
		45,000	30	40	40	40	40	50	50	50	50
		47,000	40	40	40	40	50	50	50	50	50
		49,000	40	40	50	50	50	50	60	60	60
		51,000	50	50	50	50	60	60	60	60	60
		53,000	50	50	60	60	60	75	75	75	75
600/325-400	(3) 27 1/2" x 27 1/2"	55,000	25	25	30	30	40	40	—	—	—
		58,000	25	30	40	40	40	40	—	—	—
		61,000	30	40	40	40	50	50	—	—	—
		64,000	30	40	40	50	50	50	50	—	—
		67,000	40	50	50	50	50	60	60	60	60
		70,000	40	50	50	60	60	60	60	60	60
		73,000	50	50	60	60	75	75	75	75	75
		76,000	50	60	60	60	75	75	75	75	75
		79,000	60	75	75	75	75	75	75	75	—
		81,000	60	75	75	75	75	75	—	—	—

**NOTES:**

1. Horsepower selections are based on system external static pressure. To determine total external static pressure, add all applicable accessory pressure drops listed below:
 

A. Fresh Air Inlet Hood & Birdscreen	0.13" W.C.	C. V-Bank Filter Section	0.25" W.C.
B. Motor Operated Dampers	0.13" W.C.	D. Discharge Nozzles	0.25" W.C.
2. Select unit size and motor horsepower from table above.
3. Contact factory for applications not shown.

**EXPLANATION OF MODEL NUMBERS**

**DASH MODEL NUMBERS** - A dash in the model number indicates the BTU range on the heat exchanger. Example: Model 35-40 has a heat exchanger rating of 350,000-400,000 BTU output.

**SLASH MODEL NUMBERS** - A slash in the model number indicates the use of a larger blower section with a smaller heat exchanger, normally used for low temperature rise applications. Example: Model 75/35-40 has a 75 size blower section, which offers airflow up to 10,000 CFM, with a heat exchanger rating of 350,000-400,000 BTU output.

# Air Delivery Table

Models IF & IFW										
Model	Blowers	SCFM	Total External Static Pressure (W.C.)							
			1/4"	1/2"	3/4"	1"	1 1/4"	1 1/2"	1 3/4"	2"
			HP	HP	HP	HP	HP	HP	HP	HP
600S/325-400	(3) 30" x 30"	73,000	40	40	40	50	50	60	60	—
		76,000	40	50	50	50	60	60	75	75
		79,000	50	50	50	60	60	75	75	75
		82,000	50	50	60	60	75	75	75	100
		85,000	50	60	60	75	75	75	100	100
		88,000	60	60	75	75	100	100	100	100
		91,000	60	75	75	75	100	100	100	100
		94,000	75	75	75	100	100	100	100	100
500-600	(3) 27 1/2" x 27 1/2"	55,000	25	25	30	30	40	40	—	—
		58,000	25	30	40	40	40	40	—	—
		61,000	30	40	40	40	50	50	—	—
		64,000	30	40	40	50	50	50	50	—
		67,000	40	50	50	50	50	60	60	60
		70,000	40	50	50	60	60	60	60	60
		73,000	50	50	60	60	75	75	75	75
		76,000	50	60	60	60	75	75	75	75
		79,000	60	75	75	75	75	75	75	—
		81,000	60	75	75	75	75	75	—	—
600S/500-600	(3) 30" x 30"	73,000	40	40	40	50	50	60	60	—
		76,000	40	50	50	50	60	60	75	75
		79,000	50	50	50	60	60	75	75	75
		82,000	50	50	60	60	75	75	75	100
		85,000	50	60	60	75	75	75	100	100
		88,000	60	60	75	75	100	100	100	100
		91,000	60	75	75	75	100	100	100	100
		94,000	75	75	75	100	100	100	100	100

**NOTES:**

- Horsepower selections are based on system external static pressure. To determine total external static pressure, add all applicable accessory pressure drops listed below:
  - A. Fresh Air Inlet Hood & Birdscreen 0.13" W.C.
  - B. Motor Operated Dampers 0.13" W.C.
  - C. V-Bank Filter Section 0.25" W.C.
  - D. Discharge Nozzles 0.25" W.C.
- Select unit size and motor horsepower from table above.
- Contact factory for applications not shown.

**EXPLANATION OF MODEL NUMBERS**

**DASH MODEL NUMBERS** - A dash in the model number indicates the BTU range on the heat exchanger. Example: Model 35-40 has a heat exchanger rating of 350,000-400,000 BTU output.

**SLASH MODEL NUMBERS** - A slash in the model number indicates the use of a larger blower section with a smaller heat exchanger, normally used for low temperature rise applications. Example: Model 75/35-40 has a 75 size blower section, which offers airflow up to 10,000 CFM, with a heat exchanger rating of 350,000-400,000 BTU output.

# Engineering Data

Capacity and Internal Data						
	Model Size	35	40	45	50	55
SIZE & CAPACITY	Input B.T.U./Hour	437,500	500,000	562,500	625,000	687,500
	Output B.T.U./Hour(B)	350,000	400,000	450,000	500,000	550,000
FIRING RATE & MANIFOLD SIZE	Natural Gas 1,000 B.T.U./C.F.	438	500	563	625	688
	Nat. Gas Std. Pipe Size (8 to 14" W.C.)	1"	1"	1"	1"	1"
EQUIPMENT & HEAT EXCHANGER DATA	Discharge Heads Amt./Size	2/15	2/15	3/15	3/15	3/15
	Throw W/90° Nozzles (Feet)	78	96	88	98	107
	Throw W/45° Nozzles (Feet)	87	116	100	100	120
	Combustion Air Required (C.F.M.)	110	130	145	160	180
	Exhauster Model	12	12	12	12	12
	Exhauster H.P.	1/3	1/3	1/3	1/3	1/3
	Recommended Min. Stack Size – Dia.	8"	8"	8"	8"	8"
INTERNAL DATA OF HEAT EXCHANGER (A)	Primary Heating Surface – Sq. Feet	41	41	50	50	50
	Secondary Htg. Surface (Tubes & Headers) – Sq. Feet	30	30	36	36	36
	Primary Combustion Volume – Cu. Feet	19	19	24	24	24
	Secondary Combustion Volume – Cu. Feet	3	3	4	4	4
	Total Combustion Chamber Volume – Cu. Feet	22	22	28	28	28
	Model Size	65	75	85	100	125
SIZE & CAPACITY	Input B.T.U./Hour	812,500	937,500	1,062,500	1,250,000	1,562,500
	Output B.T.U./Hour(B)	650,000	750,000	850,000	1,000,000	1,250,000
FIRING RATE & MANIFOLD SIZE	Natural Gas 1,000 B.T.U./C.F.	813	938	1,063	1,250	1,563
	Nat. Gas Std. Pipe Size (8 to 14" W.C.)	1 1/4"	1 1/4"	1 1/2"	1 1/2"	1 1/2"
EQUIPMENT & HEAT EXCHANGER DATA	Discharge Heads Amt./Size	4 /15	4/15	4 /15	4 /15	4/18
	Throw W/90° Nozzles (Feet)	95	110	124	147	153
	Throw W/45° Nozzles (Feet)	106	123	140	165	171
	Combustion Air Required (C.F.M.)	210	240	275	325	400
	Exhauster Model	14	14	14	14	18
	Exhauster H.P.	1/2	1/2	1/2	1/2	2
	Recommended Min. Stack Size – Dia.	10"	10"	10"	10"	12"
INTERNAL DATA OF HEAT EXCHANGER (A)	Primary Heating Surface – Sq. Feet	41	41	86	86	127
	Secondary Htg. Surface (Tubes & Headers) – Sq. Feet	58	58	85	85	120
	Primary Combustion Volume – Cu. Feet	34	34	48	48	88
	Secondary Combustion Volume – Cu. Feet	5	5	7	7	9
	Total Combustion Chamber Volume – Cu. Feet	39	39	55	55	97

(A) Standard construction - 400 series stainless steel primary and mild steel secondary. All stainless steel heat exchangers available for outside air and other special applications

Optional construction - 400 series stainless steel primary and secondary. Recommended when 30% or more winter outside air is introduced, or temperature rise at minimum firing rate is below 10° F.

(B) Based on 80% operating efficiency.

# Engineering Data

Capacity and Internal Data						
	Model Size	150	175	200	250	275 (C)
SIZE & CAPACITY	Input B.T.U./Hour	1,875,000	2,187,500	2,500,000	3,125,000	3,437,500
	Output B.T.U./Hour(B)	1,500,000	1,750,000	2,000,000	2,500,000	2,750,000
FIRING RATE & MANIFOLD SIZE	Natural Gas 1,000 B.T.U./C.F.	1,875	2,188	2,500	3,125	3,438
	Nat. Gas Std. Pipe Size (8 to 14" W.C.)	2"	2"	2"	2 1/2"	2 1/2"
EQUIPMENT & HEAT EXCHANGER DATA	Discharge Heads Amt./Size	4/18	4/18	5/18	5/18	6/18
	Throw W/90° Nozzles (Feet)	183	215	195	230	235
	Throw W/45° Nozzles (Feet)	205	238	218	248	262
	Combustion Air Required (C.F.M.)	480	560	650	800	880
	Exhauster Model	18	18	18	21	21
	Exhauster H.P.	2	2	2	5	5
	Recommended Min. Stack Size - Dia.	12"	12"	14"	16"	16"
INTERNAL DATA OF HEAT EXCHANGER (A)	Primary Heating Surface – Sq. Feet	127	127	165	165	186
	Secondary Htg. Surface (Tubes & Headers) – Sq. Feet	120	120	166	166	228
	Primary Combustion Volume – Cu. Feet	88	88	124	124	165
	Secondary Combustion Volume – Cu. Feet	9	9	14	14	24
	Total Combustion Chamber Volume – Cu. Feet	97	97	138	138	189

	Model Size	300 (C)	325 (C)	350 (C)	400 (C)	500 (C)	600 (C)
SIZE & CAPACITY	Input B.T.U./Hour	3,760,000	4,060,000	4,375,000	5,000,000	6,250,000	7,500,000
	Output B.T.U./Hour(B)	3,000,000	3,250,000	3,500,000	4,000,000	5,000,000	6,000,000
FIRING RATE & MANIFOLD SIZE	Natural Gas 1,000 B.T.U./C.F.	3,760	4,060	4,375	5,000	6,250	7,500
	Nat. Gas Std. Pipe Size (8 to 14" W.C.)	2 1/2"	2 1/2"	3"	3"	(CF)	(CF)
EQUIPMENT & HEAT EXCHANGER DATA	Discharge Heads Amt./Size	6/18	7/18	7/18	7/18	12/18 (D)	12/18 (D)
	Throw W/90° Nozzles (Feet)	250	260	244	269	296	354
	Throw W/45° Nozzles (Feet)	280	290	274	298	334	398
	Combustion Air Required (C.F.M.)	960	1,040	1,120	1,300	1,600	1,920
	Exhauster Model	21	21	21	21	21	21
	Exhauster H.P.	5	5	5	5	5	5
	Recommended Min. Stack Size – Dia.	16"	16"	16"	16"	18"	18"
INTERNAL DATA OF HEAT EXCHANGER (A)	Primary Heating Surface – Sq. Feet	186	264	264	264	450	450
	Secondary Htg. Surface (Tubes & Headers) – Sq. Feet	228	283	283	283	436	436
	Primary Combustion Volume – Cu. Feet	165	242	242	242	585	585
	Secondary Combustion Volume – Cu. Feet	24	28	28	28	39	39
	Total Combustion Chamber Volume – Cu. Feet	189	270	270	270	624	624

(A) Standard construction - 400 series stainless steel primary and mild steel secondary.

Optional construction - 400 series stainless steel primary and secondary.  
Recommended when 30% or more winter outside air is introduced, or temperature rise at minimum firing rate is below 10° F.

(B) Based on 80% operating efficiency.

(C) Model 275-600 shipped in two pieces. Special shipping permits and heights required. Consult factory.

(D) When all 90° nozzles are furnished (optional extra). 18" extensions for 6 are included.

# Dimensions

## Models IF, IFW Vertical Units

C000458

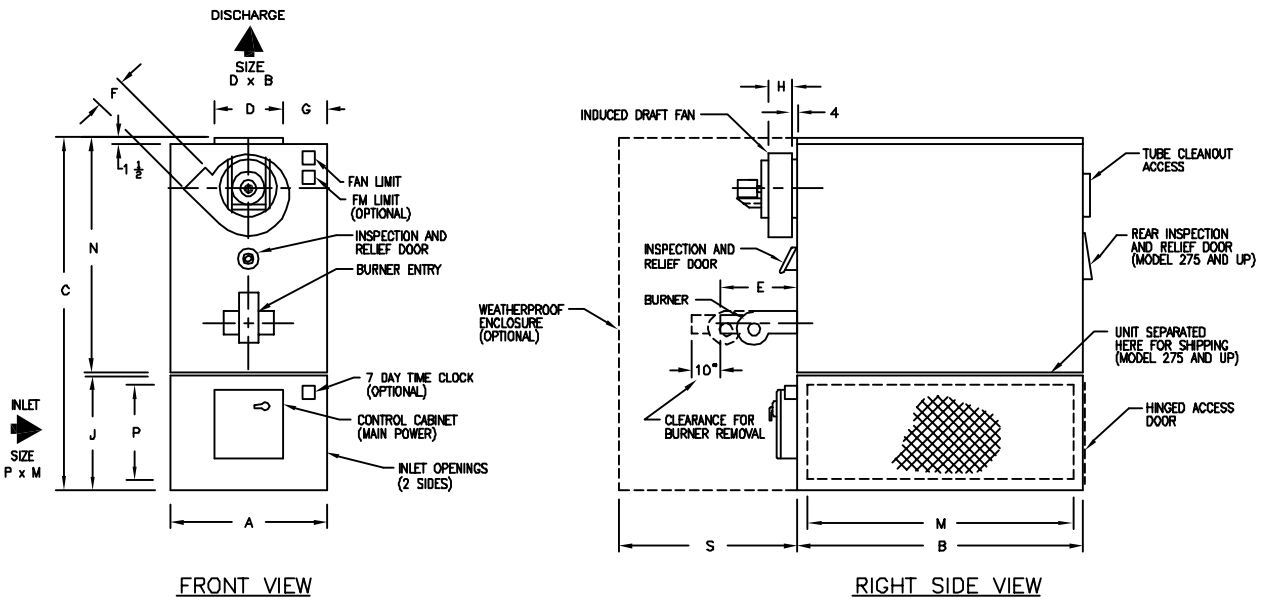

IF/IFW Model	Approximate Weight		Dimensions												
	Indoor	Outdoor	"A"	"B"	"C"	"D"	"E"	"F"	"G"	"H"	"J"	"M"	"N"	"P"	"S"
35-40	1400	1750	32	48	74 <sup>5</sup> / <sub>8</sub>	18	17	6 <sup>1</sup> / <sub>4</sub>	7	6 <sup>3</sup> / <sub>8</sub>	26 <sup>1</sup> / <sub>8</sub>	44	48 <sup>1</sup> / <sub>2</sub>	22	36
55/40	1600	1950	36	60	74 <sup>5</sup> / <sub>8</sub>	18	17	6 <sup>1</sup> / <sub>4</sub>	9	6 <sup>3</sup> / <sub>8</sub>	26 <sup>1</sup> / <sub>8</sub>	56	48 <sup>1</sup> / <sub>2</sub>	22	36
75/40	2000	2350	36	80	74 <sup>5</sup> / <sub>8</sub>	18	17	6 <sup>1</sup> / <sub>4</sub>	9	6 <sup>3</sup> / <sub>8</sub>	26 <sup>1</sup> / <sub>8</sub>	76	48 <sup>1</sup> / <sub>2</sub>	22	36
45-55	1700	2100	36	60	82 <sup>5</sup> / <sub>8</sub>	18	17	6 <sup>1</sup> / <sub>4</sub>	9	6 <sup>3</sup> / <sub>8</sub>	26 <sup>1</sup> / <sub>8</sub>	56	56 <sup>1</sup> / <sub>2</sub>	22	36
75/55	2100	2500	36	80	82 <sup>5</sup> / <sub>8</sub>	18	17	6 <sup>1</sup> / <sub>4</sub>	9	6 <sup>3</sup> / <sub>8</sub>	26 <sup>1</sup> / <sub>8</sub>	76	56 <sup>1</sup> / <sub>2</sub>	22	36
100/55	2300	2700	48	90	86 <sup>5</sup> / <sub>8</sub>	18	17	6 <sup>1</sup> / <sub>4</sub>	15	6 <sup>3</sup> / <sub>8</sub>	30 <sup>1</sup> / <sub>8</sub>	86	56 <sup>1</sup> / <sub>2</sub>	26	44
65-75	2100	2575	36	80	82 <sup>5</sup> / <sub>8</sub>	18	17	7	9	7 <sup>3</sup> / <sub>8</sub>	26 <sup>1</sup> / <sub>8</sub>	76	56 <sup>1</sup> / <sub>2</sub>	22	36
100/75	2400	2875	48	90	86 <sup>5</sup> / <sub>8</sub>	18	17	7	15	7 <sup>3</sup> / <sub>8</sub>	30 <sup>1</sup> / <sub>8</sub>	86	56 <sup>1</sup> / <sub>2</sub>	26	44
175/75	3800	4275	54	100	86 <sup>5</sup> / <sub>8</sub>	18	17	7	18	7 <sup>3</sup> / <sub>8</sub>	30 <sup>1</sup> / <sub>8</sub>	96	56 <sup>1</sup> / <sub>2</sub>	26	44
85-100	2500	3025	48	90	99 <sup>5</sup> / <sub>8</sub>	18	17	7	15	7 <sup>3</sup> / <sub>8</sub>	30 <sup>1</sup> / <sub>8</sub>	86	69 <sup>1</sup> / <sub>2</sub>	26	44
175/100	4000	4525	54	100	99 <sup>5</sup> / <sub>8</sub>	18	17	7	18	7 <sup>3</sup> / <sub>8</sub>	30 <sup>1</sup> / <sub>8</sub>	96	69 <sup>1</sup> / <sub>2</sub>	26	44
250/100	4500	5025	60	120	99 <sup>5</sup> / <sub>8</sub>	18	17	7	21	7 <sup>3</sup> / <sub>8</sub>	30 <sup>1</sup> / <sub>8</sub>	116	69 <sup>1</sup> / <sub>2</sub>	26	44
125-175	4100	4675	54	100	103 <sup>5</sup> / <sub>8</sub>	24	21	9	15	9 <sup>3</sup> / <sub>8</sub>	30 <sup>1</sup> / <sub>8</sub>	96	73 <sup>1</sup> / <sub>2</sub>	26	44
250/175	4600	5175	60	120	103 <sup>5</sup> / <sub>8</sub>	24	21	9	18	9 <sup>3</sup> / <sub>8</sub>	30 <sup>1</sup> / <sub>8</sub>	116	73 <sup>1</sup> / <sub>2</sub>	26	44
300/175	6000	6575	65	140	106 <sup>1</sup> / <sub>8</sub>	24	21	9	20 <sup>1</sup> / <sub>2</sub>	9 <sup>3</sup> / <sub>8</sub>	32 <sup>5</sup> / <sub>8</sub>	136	73 <sup>1</sup> / <sub>2</sub>	28 <sup>1</sup> / <sub>2</sub>	44
200	4600	5250	60	120	103 <sup>5</sup> / <sub>8</sub>	30	21	9	17 <sup>1</sup> / <sub>2</sub>	9 <sup>3</sup> / <sub>8</sub>	30 <sup>1</sup> / <sub>8</sub>	116	73 <sup>1</sup> / <sub>2</sub>	26	44
300/200	6000	6650	65	140	106 <sup>1</sup> / <sub>8</sub>	30	21	9	17 <sup>1</sup> / <sub>2</sub>	9 <sup>3</sup> / <sub>8</sub>	32 <sup>5</sup> / <sub>8</sub>	136	73 <sup>1</sup> / <sub>2</sub>	28 <sup>1</sup> / <sub>2</sub>	44
400/200	6650	7300	70	160	110 <sup>5</sup> / <sub>8</sub>	30	21	9	20	9 <sup>3</sup> / <sub>8</sub>	37 <sup>1</sup> / <sub>8</sub>	154	73 <sup>1</sup> / <sub>2</sub>	31	44
250	4600	5250	60	120	103 <sup>5</sup> / <sub>8</sub>	30	26	10 <sup>5</sup> / <sub>8</sub>	17 <sup>1</sup> / <sub>2</sub>	11 <sup>1</sup> / <sub>8</sub>	30 <sup>1</sup> / <sub>8</sub>	116	73 <sup>1</sup> / <sub>2</sub>	26	44
300/250	6000	6650	65	140	106 <sup>1</sup> / <sub>8</sub>	30	26	10 <sup>5</sup> / <sub>8</sub>	17 <sup>1</sup> / <sub>2</sub>	11 <sup>1</sup> / <sub>8</sub>	32 <sup>5</sup> / <sub>8</sub>	136	73 <sup>1</sup> / <sub>2</sub>	28 <sup>1</sup> / <sub>2</sub>	44
400/250	6650	7300	70	160	110 <sup>5</sup> / <sub>8</sub>	30	26	10 <sup>5</sup> / <sub>8</sub>	20	11 <sup>1</sup> / <sub>8</sub>	37 <sup>1</sup> / <sub>8</sub>	154	73 <sup>1</sup> / <sub>2</sub>	31	44
275-300	6100	7500	65	140	118 <sup>1</sup> / <sub>8</sub>	30	26	10 <sup>5</sup> / <sub>8</sub>	17 <sup>1</sup> / <sub>2</sub>	11 <sup>1</sup> / <sub>8</sub>	32 <sup>5</sup> / <sub>8</sub>	136	85 <sup>1</sup> / <sub>2</sub>	28 <sup>1</sup> / <sub>2</sub>	44
400/300	6800	8200	70	160	122 <sup>5</sup> / <sub>8</sub>	30	26	10 <sup>5</sup> / <sub>8</sub>	20	11 <sup>1</sup> / <sub>8</sub>	37 <sup>1</sup> / <sub>8</sub>	154	85 <sup>1</sup> / <sub>2</sub>	31	44
600/300	9000	10,400	80	180	141 <sup>5</sup> / <sub>8</sub>	30	26	10 <sup>5</sup> / <sub>8</sub>	25	11 <sup>1</sup> / <sub>8</sub>	56 <sup>1</sup> / <sub>8</sub>	174	85 <sup>1</sup> / <sub>2</sub>	50	44
325-400	7000	8700	70	160	138 <sup>5</sup> / <sub>8</sub>	30	32	10 <sup>5</sup> / <sub>8</sub>	20	11 <sup>1</sup> / <sub>8</sub>	37 <sup>1</sup> / <sub>8</sub>	154	101 <sup>1</sup> / <sub>2</sub>	31	44
600/400	9500	11,200	80	180	157 <sup>5</sup> / <sub>8</sub>	30	32	10 <sup>5</sup> / <sub>8</sub>	25	11 <sup>1</sup> / <sub>8</sub>	56 <sup>1</sup> / <sub>8</sub>	174	101 <sup>1</sup> / <sub>2</sub>	50	44
500/600	10,500	12,500	80	180	198 <sup>5</sup> / <sub>8</sub>	48	32	10 <sup>5</sup> / <sub>8</sub>	16	11 <sup>1</sup> / <sub>8</sub>	56 <sup>1</sup> / <sub>8</sub>	174	142 <sup>1</sup> / <sub>2</sub>	50	44
600S/600	12,500	14,500	85	200	198 <sup>5</sup> / <sub>8</sub>	48	32	10 <sup>5</sup> / <sub>8</sub>	18 <sup>1</sup> / <sub>2</sub>	11 <sup>1</sup> / <sub>8</sub>	56 <sup>1</sup> / <sub>8</sub>	194	142 <sup>1</sup> / <sub>2</sub>	50	44

**NOTE:** All dimensions in inches subject to manufacturing tolerances.

### EXPLANATION OF MODEL NUMBERS

**DASH MODEL NUMBERS** - A Dash in the model number indicates the BTU range on the heat exchanger. Example: Model 35-40 has a heat exchanger rating of 350,000-400,000 BTU output.

**SLASH MODEL NUMBERS** - A Slash in the model number indicates the use of a larger blower section with a smaller heat exchanger, normally used for low temperature rise applications. Example: Model 75/35-40 has a 75 size blower section, which offers airflow up to 10,000 CFM, with a heat exchanger rating of 350,000-400,000 BTU output.

# Dimensions

## Models IF, IFW Horizontal Units

C000458

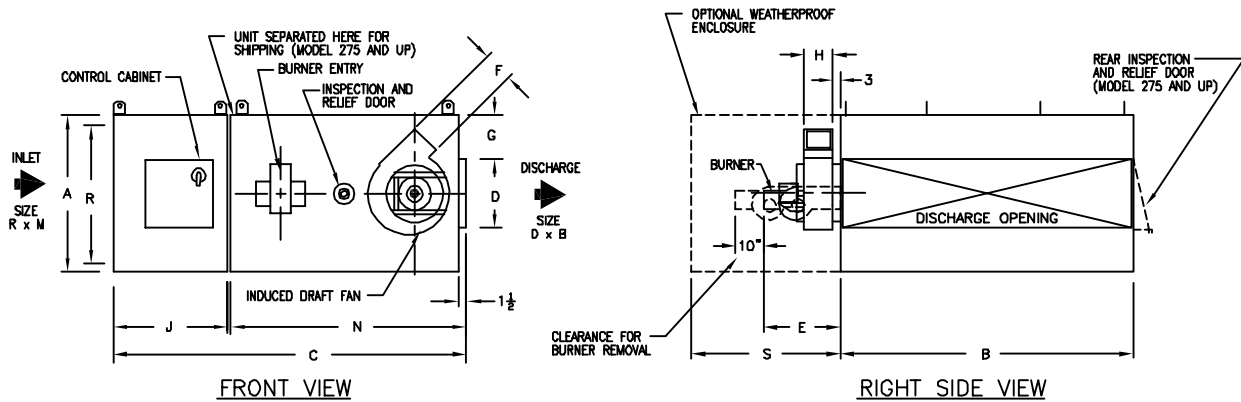

IF/IFW Model	Approximate Weight		Dimensions												
	Indoor	Outdoor	"A"	"B"	"C"	"D"	"E"	"F"	"G"	"H"	"J"	"M"	"N"	"R"	"S"
35-40	1400	1750	32	48	74 <sup>5</sup> / <sub>8</sub>	18	17	6 <sup>1</sup> / <sub>4</sub>	7	6 <sup>3</sup> / <sub>8</sub>	26 <sup>1</sup> / <sub>8</sub>	44	48 <sup>1</sup> / <sub>2</sub>	28	36
55/40	1600	1950	36	60	74 <sup>5</sup> / <sub>8</sub>	18	17	6 <sup>1</sup> / <sub>4</sub>	9	6 <sup>3</sup> / <sub>8</sub>	26 <sup>1</sup> / <sub>8</sub>	56	48 <sup>1</sup> / <sub>2</sub>	32	36
75/40	2000	2350	36	80	74 <sup>5</sup> / <sub>8</sub>	18	17	6 <sup>1</sup> / <sub>4</sub>	9	6 <sup>3</sup> / <sub>8</sub>	26 <sup>1</sup> / <sub>8</sub>	76	48 <sup>1</sup> / <sub>2</sub>	32	36
45-55	1700	2100	36	60	82 <sup>5</sup> / <sub>8</sub>	18	17	6 <sup>1</sup> / <sub>4</sub>	9	6 <sup>3</sup> / <sub>8</sub>	26 <sup>1</sup> / <sub>8</sub>	56	56 <sup>1</sup> / <sub>2</sub>	32	36
75/55	2100	2500	36	80	82 <sup>5</sup> / <sub>8</sub>	18	17	6 <sup>1</sup> / <sub>4</sub>	9	6 <sup>3</sup> / <sub>8</sub>	26 <sup>1</sup> / <sub>8</sub>	76	56 <sup>1</sup> / <sub>2</sub>	32	36
100/55	2300	2700	48	90	86 <sup>5</sup> / <sub>8</sub>	18	17	6 <sup>1</sup> / <sub>4</sub>	15	6 <sup>3</sup> / <sub>8</sub>	30 <sup>1</sup> / <sub>8</sub>	86	56 <sup>1</sup> / <sub>2</sub>	44	44
65-75	2100	2575	36	80	82 <sup>5</sup> / <sub>8</sub>	18	17	7	9	7 <sup>3</sup> / <sub>8</sub>	26 <sup>1</sup> / <sub>8</sub>	76	56 <sup>1</sup> / <sub>2</sub>	32	36
100/75	2400	2875	48	90	86 <sup>5</sup> / <sub>8</sub>	18	17	7	15	7 <sup>3</sup> / <sub>8</sub>	30 <sup>1</sup> / <sub>8</sub>	86	56 <sup>1</sup> / <sub>2</sub>	44	44
175/75	3800	4275	54	100	86 <sup>5</sup> / <sub>8</sub>	18	17	7	18	7 <sup>3</sup> / <sub>8</sub>	30 <sup>1</sup> / <sub>8</sub>	96	56 <sup>1</sup> / <sub>2</sub>	50	44
85-100	2500	3025	48	90	99 <sup>5</sup> / <sub>8</sub>	18	17	7	15	7 <sup>3</sup> / <sub>8</sub>	30 <sup>1</sup> / <sub>8</sub>	86	69 <sup>1</sup> / <sub>2</sub>	44	44
175/100	4000	4525	54	100	99 <sup>5</sup> / <sub>8</sub>	18	17	7	18	7 <sup>3</sup> / <sub>8</sub>	30 <sup>1</sup> / <sub>8</sub>	96	69 <sup>1</sup> / <sub>2</sub>	50	44
250/100	4500	5025	60	120	99 <sup>5</sup> / <sub>8</sub>	18	17	7	21	7 <sup>3</sup> / <sub>8</sub>	30 <sup>1</sup> / <sub>8</sub>	116	69 <sup>1</sup> / <sub>2</sub>	56	44
125-175	4100	4675	54	100	103 <sup>5</sup> / <sub>8</sub>	24	21	9	15	9 <sup>3</sup> / <sub>8</sub>	30 <sup>1</sup> / <sub>8</sub>	96	73 <sup>1</sup> / <sub>2</sub>	50	44
250/175	4600	5175	60	120	103 <sup>5</sup> / <sub>8</sub>	24	21	9	18	9 <sup>3</sup> / <sub>8</sub>	30 <sup>1</sup> / <sub>8</sub>	116	73 <sup>1</sup> / <sub>2</sub>	56	44
300/175	6000	6575	65	140	106 <sup>1</sup> / <sub>8</sub>	24	21	9	20 <sup>1</sup> / <sub>2</sub>	9 <sup>3</sup> / <sub>8</sub>	32 <sup>5</sup> / <sub>8</sub>	136	73 <sup>1</sup> / <sub>2</sub>	61	44
200	4600	5250	60	120	103 <sup>5</sup> / <sub>8</sub>	30	21	9	17 <sup>1</sup> / <sub>2</sub>	9 <sup>3</sup> / <sub>8</sub>	30 <sup>1</sup> / <sub>8</sub>	116	73 <sup>1</sup> / <sub>2</sub>	56	44
300/200	6000	6650	65	140	106 <sup>1</sup> / <sub>8</sub>	30	21	9	17 <sup>1</sup> / <sub>2</sub>	9 <sup>3</sup> / <sub>8</sub>	32 <sup>5</sup> / <sub>8</sub>	136	73 <sup>1</sup> / <sub>2</sub>	61	44
400/200	6650	7300	70	160	110 <sup>5</sup> / <sub>8</sub>	30	21	9	20	9 <sup>3</sup> / <sub>8</sub>	37 <sup>1</sup> / <sub>8</sub>	154	73 <sup>1</sup> / <sub>2</sub>	64	44
250	4600	5250	60	120	103 <sup>5</sup> / <sub>8</sub>	30	26	10 <sup>5</sup> / <sub>8</sub>	17 <sup>1</sup> / <sub>2</sub>	11 <sup>1</sup> / <sub>8</sub>	30 <sup>1</sup> / <sub>8</sub>	116	73 <sup>1</sup> / <sub>2</sub>	56	44
300/250	6000	6650	65	140	106 <sup>1</sup> / <sub>8</sub>	30	26	10 <sup>5</sup> / <sub>8</sub>	17 <sup>1</sup> / <sub>2</sub>	11 <sup>1</sup> / <sub>8</sub>	32 <sup>5</sup> / <sub>8</sub>	136	73 <sup>1</sup> / <sub>2</sub>	61	44
400/250	6650	7300	70	160	110 <sup>5</sup> / <sub>8</sub>	30	26	10 <sup>5</sup> / <sub>8</sub>	20	11 <sup>1</sup> / <sub>8</sub>	37 <sup>1</sup> / <sub>8</sub>	154	73 <sup>1</sup> / <sub>2</sub>	64	44
275-300	6100	7500	65	140	118 <sup>1</sup> / <sub>8</sub>	30	26	10 <sup>5</sup> / <sub>8</sub>	17 <sup>1</sup> / <sub>2</sub>	11 <sup>1</sup> / <sub>8</sub>	32 <sup>5</sup> / <sub>8</sub>	136	85 <sup>1</sup> / <sub>2</sub>	61	44
400/300	6800	8200	70	160	122 <sup>5</sup> / <sub>8</sub>	30	26	10 <sup>5</sup> / <sub>8</sub>	20	11 <sup>1</sup> / <sub>8</sub>	37 <sup>1</sup> / <sub>8</sub>	154	85 <sup>1</sup> / <sub>2</sub>	64	44
600/300	9000	10,400	80	180	141 <sup>5</sup> / <sub>8</sub>	30	26	10 <sup>5</sup> / <sub>8</sub>	25	11 <sup>1</sup> / <sub>8</sub>	56 <sup>1</sup> / <sub>8</sub>	174	85 <sup>1</sup> / <sub>2</sub>	74	44
325-400	7000	8700	70	160	138 <sup>5</sup> / <sub>8</sub>	30	32	10 <sup>5</sup> / <sub>8</sub>	20	11 <sup>1</sup> / <sub>8</sub>	37 <sup>1</sup> / <sub>8</sub>	154	101 <sup>1</sup> / <sub>2</sub>	64	44
600/400	9500	11,200	80	180	157 <sup>5</sup> / <sub>8</sub>	30	32	10 <sup>5</sup> / <sub>8</sub>	25	11 <sup>1</sup> / <sub>8</sub>	56 <sup>1</sup> / <sub>8</sub>	174	101 <sup>1</sup> / <sub>2</sub>	74	44
500/600	10,500	12,500	80	180	198 <sup>5</sup> / <sub>8</sub>	48	32	10 <sup>5</sup> / <sub>8</sub>	16	11 <sup>1</sup> / <sub>8</sub>	56 <sup>1</sup> / <sub>8</sub>	174	142 <sup>1</sup> / <sub>2</sub>	74	44
600S/600	12,500	14,500	85	200	198 <sup>5</sup> / <sub>8</sub>	48	32	10 <sup>5</sup> / <sub>8</sub>	18 <sup>1</sup> / <sub>2</sub>	11 <sup>1</sup> / <sub>8</sub>	56 <sup>1</sup> / <sub>8</sub>	194	142 <sup>1</sup> / <sub>2</sub>	79	44

**NOTE:** All dimensions in inches subject to manufacturing tolerances.

### EXPLANATION OF MODEL NUMBERS

**DASH MODEL NUMBERS** - A Dash in the model number indicates the BTU range on the heat exchanger. Example: Model 35-40 has a heat exchanger rating of 350,000-400,000 BTU output.

**SLASH MODEL NUMBERS** - A Slash in the model number indicates the use of a larger blower section with a smaller heat exchanger, normally used for low temperature rise applications. Example: Model 75/35-40 has a 75 size blower section, which offers airflow up to 10,000 CFM, with a heat exchanger rating of 350,000-400,000 BTU output.

# Dimensions

## Model IF, IFW Side V-Bank Filter with Mixing Box

C000510

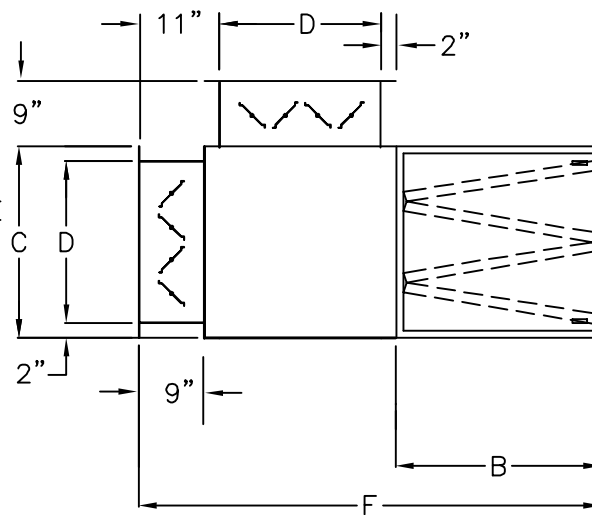
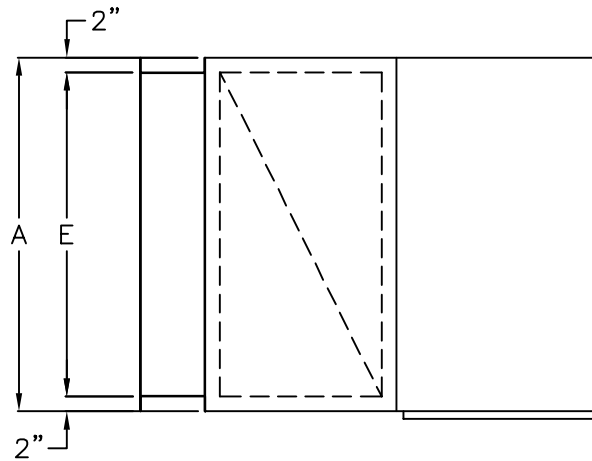

1. ACCESS DOOR CAN BE AT EITHER END BUT NOT BOTH (SPECIFY)



Model	A	B	C	D	E	F	Number & Size of Filters	Approximate Weight	
								V-Bank	V-Bank/Mixing Section
35-40	48	28	26	22	44	63	(6) 16 x 25 x 2	187	524
45-55	60	24	26	22	56	59	(9) 20 x 20 x 2	211	582
65-75	80	24	26	22	76	59	(12) 20 x 20 x 2	262	763
85-100	90	24	30	26	86	63	(16) 20 x 20 x 2	321	872
125-175	100	44	30	26	96	83	(30) 20 x 20 x 2	492	1221
200-250	120	44	30	26	116	83	(36) 20 x 20 x 2	682	1515
275-300	140	44	32 <sup>1</sup> / <sub>2</sub>	28 <sup>1</sup> / <sub>2</sub>	136	85 <sup>1</sup> / <sub>2</sub>	(49) 20 x 20 x 2	853	1937
325-400	160	44	37	33	156	90	(64) 20 x 20 x 2	1057	2601
500-600	180	44	56	52	176	109	(90) 20 x 20 x 2	1336	3702

### NOTES:

1. All dimensions in inches subject to manufacturing tolerances.
2. Use dimension "B" for V-bank filter section only.
3. Dampers may be shipped loose, to meet shipping restrictions; field adaptation and mounting by others.
4. Damper blade dividers furnished as required.

# Dimensions

## Model IF, IFW Base V-Bank Filter with Mixing Box

C000511

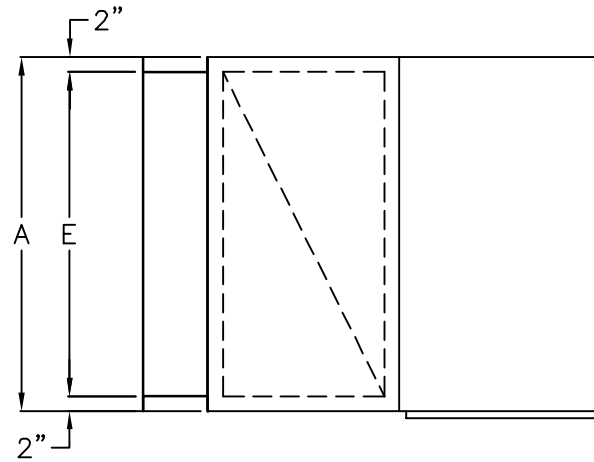

1. ACCESS DOOR CAN BE AT EITHER END BUT NOT BOTH (SPECIFY)
2. ONE DAMPER CAN BE LOCATED IN EITHER TOP OR BOTTOM LOCATION (SPECIFY CHOICE)

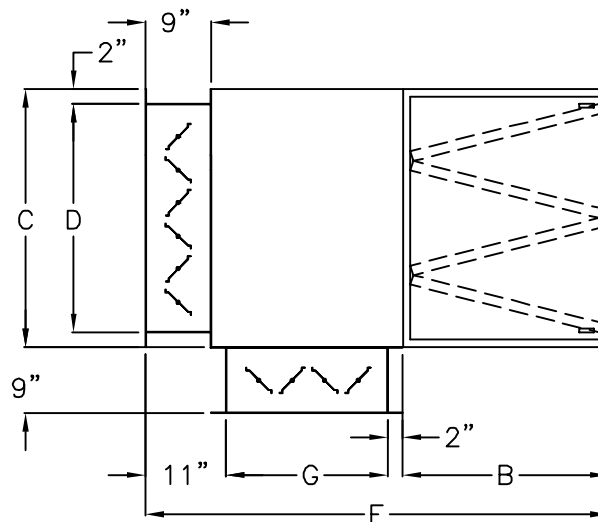

Model	A	B	C	D	E	F	G	Number & Size of Filters	Approximate Weight	
									V-Bank	V-Bank/Mixing Section
35-40	48	24	32	28	44	59	22	(6) 16 x 25 x 2	192	628
45-55	60	24	36	32	56	59	22	(9) 20 x 20 x 2	241	773
65-75	80	24	36	32	76	59	22	(12) 20 x 20 x 2	276	925
85-100	90	24	48	44	86	63	26	(16) 20 x 20 x 2	362	1202
125-175	100	44	54	50	96	83	26	(30) 20 x 20 x 2	517	1603
200-250	120	44	60	56	116	83	26	(36) 20 x 20 x 2	583	1986
275-300	140	24	65	61	136	65 1/2	32 1/2	(49) 20 x 20 x 2	779	2342
325-400	160	24	70	66	156	70	37	(64) 20 x 20 x 2	1016	3057
500-600	180	29	80	76	176	94	56	(90) 20 x 20 x 2	1636	4441

### NOTES:

1. All dimensions in inches subject to manufacturing tolerances.
2. Use dimension "B" for V-bank filter section only.
3. Dampers may be shipped loose, to meet shipping restriction; field adaptation and mounting by others.
4. Damper blade dividers furnished as required.

# Dimensions

## Model IF, IFW Base Inlet Damper

C000512

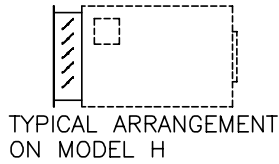
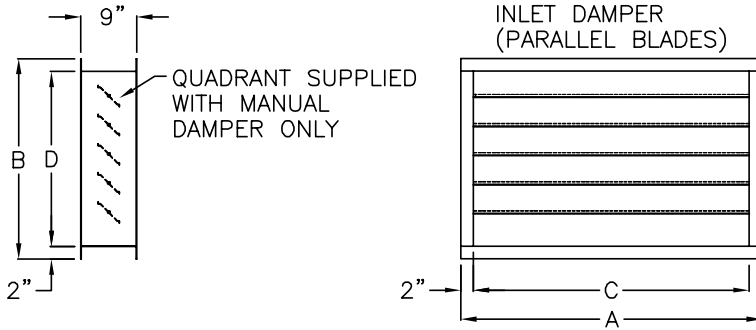

Model	A	B	C	D	Approximate Weight
35-40	48	32	44	28	128
45-55	60	36	56	32	161
65-75	80	36	76	32	194
85-100	90	48	86	44	251
125-175	100	56	96	50	328
200-250	120	60	116	56	426
275-300	140	65	132	61	535
325-400	160	70	154	66	606
500-600	180	80	174	74	953

### NOTES

1. All dimensions in inches subject to manufacturing tolerances.
2. Dampers may be shipped loose, to meet shipping restrictions; field adaptation and mounting by others.
3. Blade dividers furnished as required.

## Model IF, IFW Side Inlet Damper

C000512

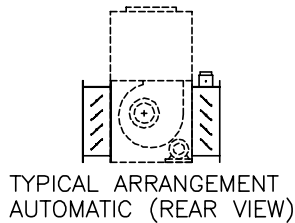
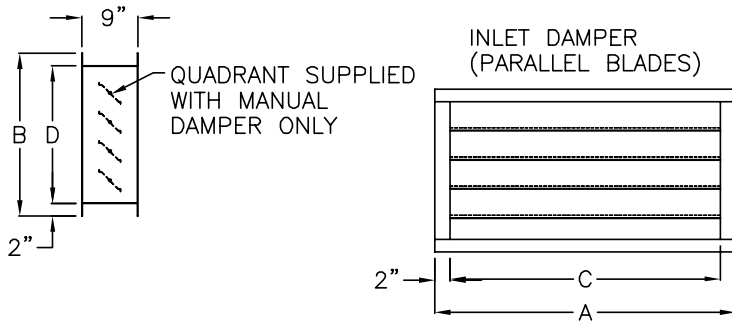

Model	A	B	C	D	Approximate Weight
35-40	48	26	43 <sup>1</sup> / <sub>8</sub>	22	110
45-55	60	26	55 <sup>5</sup> / <sub>8</sub>	22	122
65-75	80 <sup>1</sup> / <sub>4</sub>	26	75 <sup>1</sup> / <sub>4</sub>	22	150
85-100	90	30	86	26	173
125-175	100 <sup>1</sup> / <sub>8</sub>	30	95 <sup>3</sup> / <sub>4</sub>	26	257
200-250	120	30	115 <sup>5</sup> / <sub>8</sub>	26	304
275-300	140	32 <sup>1</sup> / <sub>2</sub>	135 <sup>1</sup> / <sub>2</sub>	28	367
325-400	159 <sup>1</sup> / <sub>8</sub>	37	151 <sup>7</sup> / <sub>8</sub>	32 <sup>1</sup> / <sub>4</sub>	487
500-600	180	56	173 <sup>1</sup> / <sub>2</sub>	51	727

### NOTES

1. All dimensions in inches subject to manufacturing tolerances.
2. Dampers may be shipped loose, to meet shipping restrictions; field adaptation and mounting by others.
3. Blade dividers furnished as required.

# Dimensions

## Model IF Service Platform

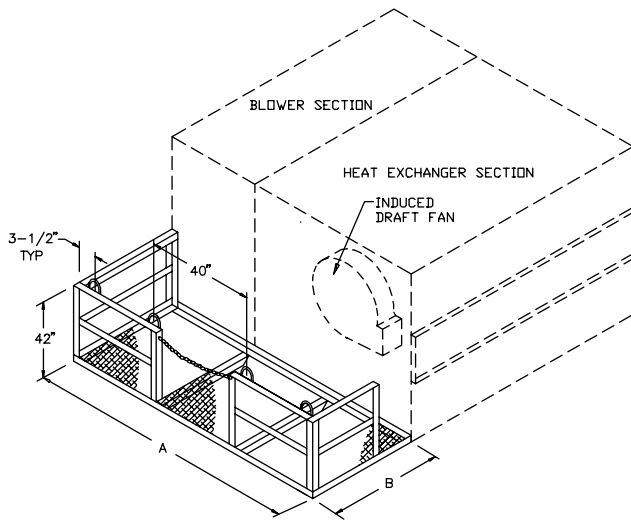

Model	A	B	Approximate Weight
35-40	73	48	185
45-55	81	48	248
65-75	81	48	248
85-100	92	48	265
125-175	102	48	326
200-250	102	48	326

### NOTES

1. All dimensions in inches subject to manufacturing tolerances.
2. Contact factory for dimensional details on units larger than 250 or models with optional V-bank or V-bank/mixing section.

## Model IF Discharge Nozzle

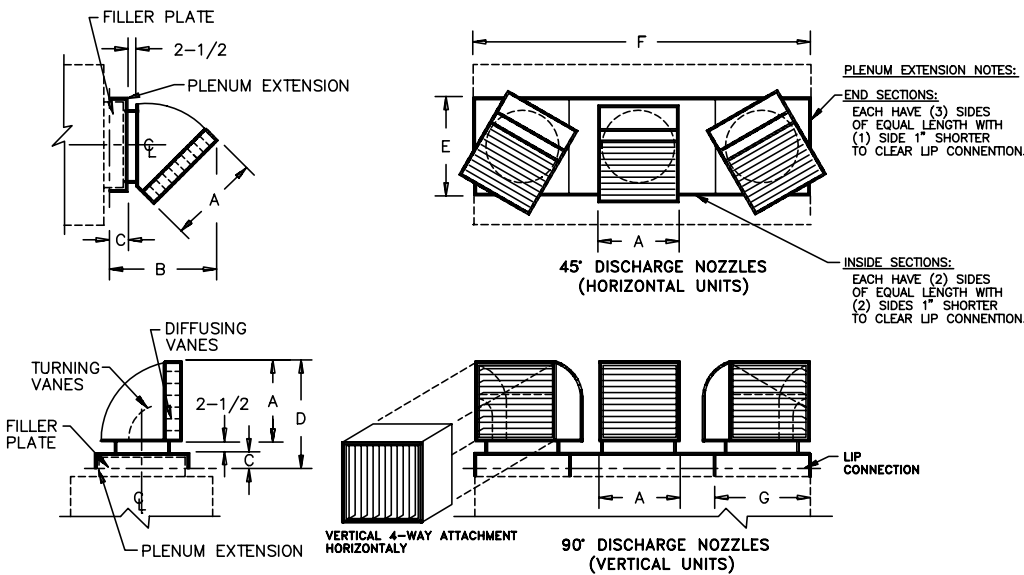

### NOTES

1. Nozzles 360° rotatable.
2. Diffusing vanes are adjustable.
3. Nozzles supplied as optional.
4. All dimensions in inches subject to manufacturing tolerances.
5. Nozzles and one piece filler plate (Model 35-55) or plenum extensions (Model 65-400) shipped separately for field adaptation by others.
6. Overall height of nozzles and extensions or filler plate furnished for remote mounting is (1) inch plus "B" or "D" dimension.
7. Plenum extensions are furnished in "sections". Each extension has (2) end sections and inside sections as required. Total number of plenum extension sections equals the number of nozzles furnished per model heater.
8. For slash units (400/200, etc.) consult factory.

Model	A	B	C	D	E	F	G	Number of Nozzles and Size	Approximate Weight
35-40	15	19	1/2	18	18	48	—	2 EA. - 15"	79
45-55	15	19	1/2	18	18	60	—	3 EA. - 15"	113
65-75	15	25	6	23 1/2	18	80	20	4 EA. - 15"	189
85-100	15	25	6	23 1/2	18	90	20	4 EA. - 15"	189
125-175	18	31	10	30 1/2	24	100	25	4 EA. - 18"	276
200-250	18	31	10	30 1/2	30	120	24	5 EA. - 18"	364
275-300	18	31	10	30 1/2	30	140	23 3/8	6 EA. - 18"	436
325-400	18	31	10	30 1/2	30	160	22 7/8	7 EA. - 18"	503
500-600	Consult Factory								

## Model IFW Intake Hood

C000515

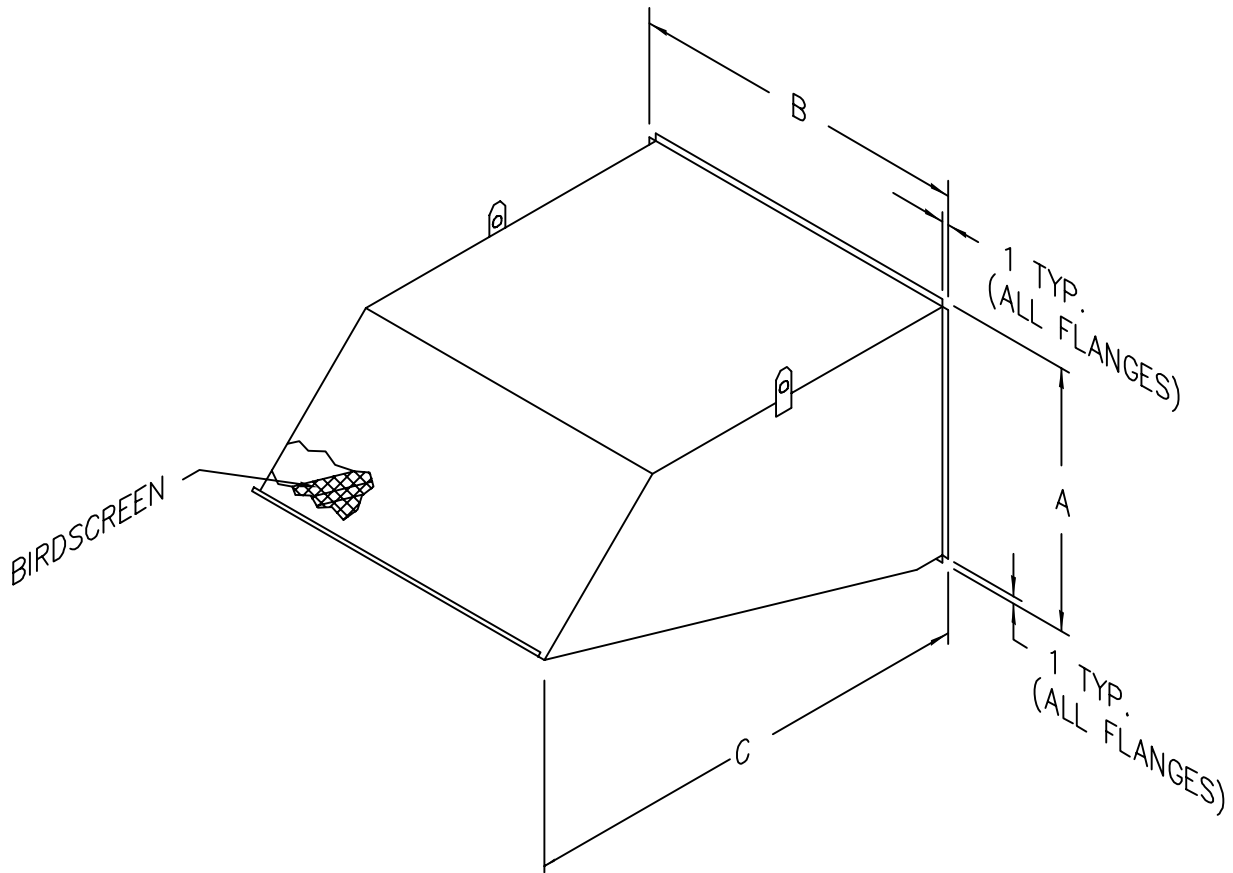

Model	A	B	C	Approximate Weight
35-40	32	48	25 <sup>7</sup> / <sub>8</sub>	85
45-55	36	60	24 <sup>1</sup> / <sub>8</sub>	98
65-75	36	80	25 <sup>7</sup> / <sub>8</sub>	110
85-100	48	90	28 <sup>1</sup> / <sub>2</sub>	179
125-175	54	100	46 <sup>3</sup> / <sub>4</sub>	296
200-250	60	120	55 <sup>3</sup> / <sub>4</sub>	402
275-300	65	140	54 <sup>3</sup> / <sub>4</sub>	492
325-400	70	160	66	763
500-600	80	180	107 <sup>5</sup> / <sub>8</sub>	1405

### NOTES

1. All dimensions in inches subject to manufacturing tolerances.
2. Hoods may be shipped loose, to meet shipping restrictions; field adaptation and mounting by others.

# Electrical Data

## Amp Draw Table

### Item A

SOURCE	AMPS	MOTOR HORSEPOWER							
		1½	2	3	5	7½	10	15	20
Blower Motor	AMPS for 208V 3 Ph.	4.5	5.9	8.7	13.7	22.2	28.2	44.8	61.0
	AMPS for 230V 3 Ph.	4.2	5.6	8.0	13.2	21.6	28.0	40.6	50.0
	AMPS for 460V 3 Ph.	2.1	2.8	4.0	6.6	10.8	14.0	20.3	25.0
SOURCE	AMPS	MOTOR HORSEPOWER							
		25	30	40	50	60	75	100	
Blower Motor	AMPS for 208V 3 Ph.	74.0	87.0	N/A	N/A	N/A	N/A	N/A	N/A
	AMPS for 230V 3 Ph.	62.0	71.0	95.6	124.0	144.0	N/A	N/A	N/A
	AMPS for 460V 3 Ph.	31.0	35.5	47.8	62.0	72.0	88.0	117.0	

### Item B

		BURNER SIZE						
		35	40	45	50	55	65	75
Blower Motor HP (Standard Power Flame Burner)		1/4	1/4	1/4	1/4	1/4	1/3	1/3
Induced Draft Fan Motor HP		1/3	1/3	1/3	1/3	1/3	1/2	1/2
Amp Draw for Burner Motor, Induced Draft Motor and Control Transformer	200 Volt 3 Phase	7.50	7.50	7.50	7.50	7.50	10.00	10.00
	230 Volt 3 Phase	6.52	6.52	6.52	6.52	6.52	8.70	8.70
	460 Volt 3 Phase	3.26	3.26	3.26	3.26	3.26	4.35	4.35
		BURNER SIZE						
		85	100	125	150	175	200	250
Blower Motor HP (Standard Power Flame Burner)		1/3	1/3	1/3	1/3	1/3	3/4	1½
Induced Draft Fan Motor HP		1/2	1/2	2	2	2	2	5
Amp Draw for Burner Motor, Induced Draft Motor and Control Transformer	200 Volt 3 Phase	10.00	10.00	10.90	10.90	10.90	11.50	21.50
	230 Volt 3 Phase	8.70	8.70	9.95	9.95	9.95	10.50	20.00
	460 Volt 3 Phase	4.35	4.35	4.97	4.97	4.97	5.19	9.90
		BURNER SIZE						
		275	300	325	350	400	500	600
Blower Motor HP (Standard Power Flame Burner)		1½	1½	1½	3	3	5	5
Induced Draft Fan Motor HP		5	5	5	5	5	5	5
Amp Draw for Burner Motor, Induced Draft Motor and Control Transformer	200 Volt 3 Phase	21.50	21.50	21.50	21.50	25.90	30.70	30.70
	230 Volt 3 Phase	20.00	20.00	20.00	20.00	23.80	28.00	28.00
	460 Volt 3 Phase	9.90	9.90	9.90	9.90	11.70	13.70	13.70

Steps to size optional disconnect switch

1. Find blower motor HP required from tables on pages 4-8.
2. Find amp draw for required motor HP in upper chart.
3. Determine proper burner size required.
4. Find amp draw for burner motor, ID fan motor, & control circuit from lower chart.
5. Add amps from step 2 and step 4, then multiply by 1.25.

# Gas Piping Layout

## Schematic Component Diagrams

C000513

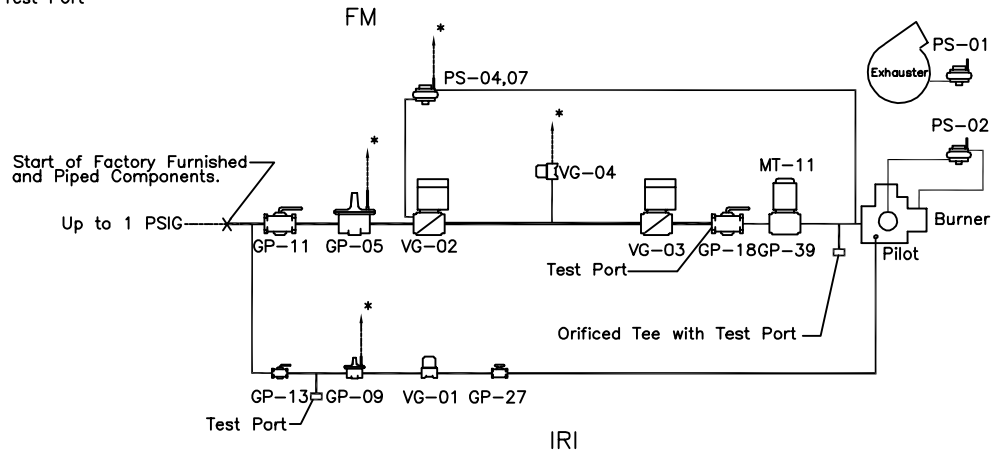
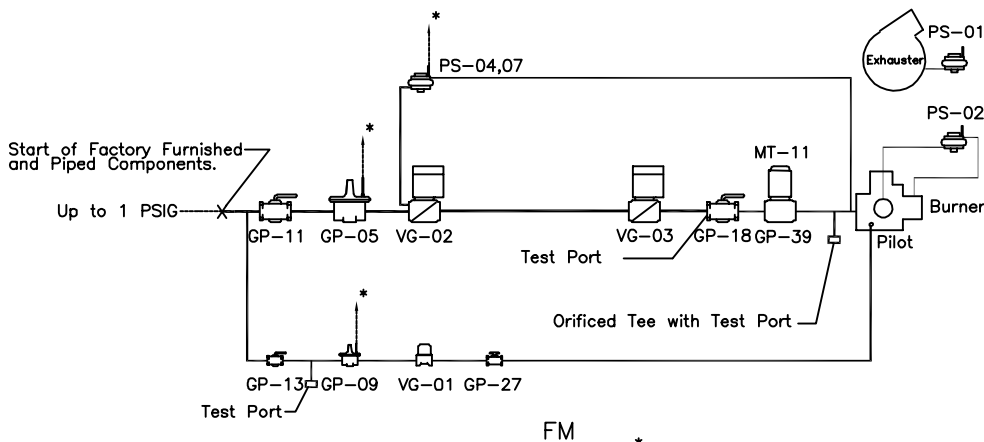
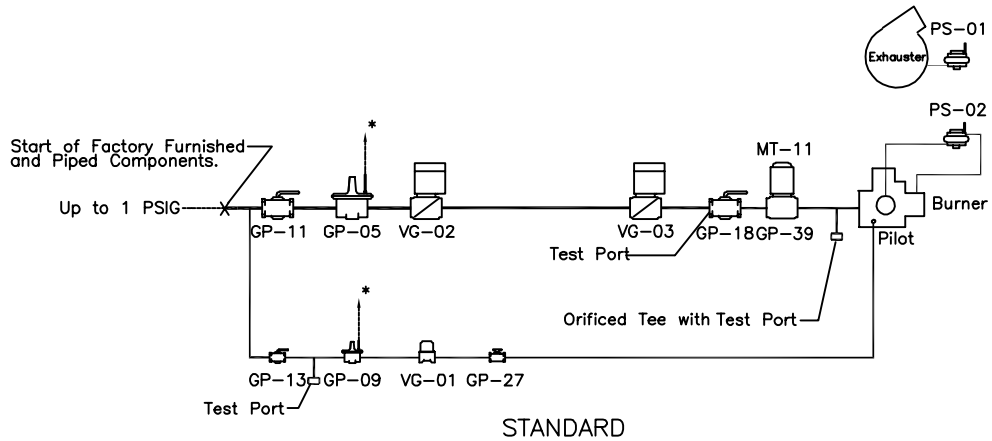

### COMPONENT IDENTIFICATION

GP-05 MAIN GAS PRESSURE REGULATOR  
 GP-09 PILOT GAS PRESSURE REGULATOR  
 GP-11 MAIN GAS SHUT-OFF VALVE  
 GP-13 PILOT GAS SHUT-OFF VALVE  
 GP-18 AUXILIARY GAS SHUT-OFF VALVE  
 GP-27 ORIFICED NEEDLE VALVE  
 GP-39 BUTTERFLY VALVE  
 (MODULATING BURNERS ONLY)  
 MT-11 BUTTERFLY VALVE OPERATOR  
 (MODULATING BURNERS ONLY)

PS-01 DRAFT PROVING SWITCH  
 PS-02 BURNER AIR FLOW SWITCH  
 PS-04 LOW GAS PRESSURE SWITCH  
 PS-07 HIGH GAS PRESSURE SWITCH  
 VG-01 PILOT GAS VALVE  
 VG-02 MAIN GAS VALVE  
 VG-03 AUXILIARY GAS VALVE  
 VG-04 N/O VENT VALVE

### NOTES:

1. Vent limiting devices provided wherever possible, when venting is required \* the venting to outside is by others on indoor units and furnished by factory on outdoor units.
2. Models through 750 MBH output require 6" W.C. minimum inlet pressure. Larger models require 8" W.C. minimum inlet pressure. Contact factory for inlet pressures below these minimums.
3. Standard manifold meets FM requirements for units less than or equal to 2000 MBH output for ETL listed units.
4. Standard manifold meets IRI requirements for ETL listed units.

# Guide Specifications



Base Bid Applied Air Model (IF) (IFW) \_\_\_\_\_  
Indirect Fired heating and make-up air unit(s) designed for (indoor) (outdoor) application. The unit shall be factory fabricated, assembled, wired and tested prior to shipment in accordance with the specification and equipment schedule. The unit will include all components herein and as shown on the drawings. Alternate equipment, equal in design, construction, performance and capacity to unit(s) specified, must be shown with price deduct/add, if any. Approval of alternate equipment will be subject to review of shop drawings. The unit shall be capable of delivering \_\_\_\_\_ SCFM at \_\_\_\_\_ ESP using a \_\_\_\_\_ horsepower (ODP) (TEFC) motor operating on 208/230/460/3/60. The unit shall be ETL listed.

## CASING

The unit casing shall consist of 18 gauge galvanized steel panels over a structural steel framework to ensure rigidity. Cabinet construction shall allow unit(s) to be mounted in the (vertical) (horizontal) arrangement with no external framework. The casing enclosing the heat exchanger shall be of double wall construction with a galvanized steel inner wall serving as a radiation shield. Radiation and transmission losses shall not exceed 2% of the rated output. This section shall be insulated with 1", 1 1/2 lb. density insulation.

Hinged access doors with cadmium plated piano type hinges shall be supplied to allow physical entry to all sections requiring inspections and periodic maintenance. Access doors shall be complete with 1" thick insulation, interior metal liner, captive screws, fasteners, and handles.

## IFW MODELS ONLY

The unit shall have a weatherproof enclosure to protect the gas burner, direct drive induced draft fan, and controls. The enclosure will be complete with hinged access doors, captive screws, fasteners and handles. The weatherproof enclosure will have louvered panels to provide outside air required for proper combustion and cooling. Flue products will be vented outside of enclosure.

## BLOWER SECTION

Each unit shall be supplied with multiple centrifugal forward curve, DWDI blowers rated in accordance with AMCA standards. The blowers are to be mounted on a heavy duty, turned and ground and polished solid steel shaft designed for a maximum operating speed not to exceed 75% of its first critical speed.

The bearings are to be of the heavy-duty industrial pre-lubricated, self aligning type. Models 125 and larger will include a double row spherical roller bearing on drive side for maximum bearing life.

Drives shall have a capacity 25% greater than the motor horsepower. Blower and motor sheaves shall be laser aligned to provide maximum belt and sheave life. The motor sheave shall be of the adjustable pitch type for motors up to 7 1/2 H.P.

The fan motor shall be mounted on an adjustable base and wired in flexible conduit to the control panel in the factory. All units with three or more bearings will be laser aligned in the factory to provide minimum vibration and maximum bearing life. All models 125 and larger shall be vibration balanced as a complete assembly in the factory.

## INDIRECT GAS FIRED SECTION

The entire primary heat transfer surface and header shall be of 400 series stainless steel; the secondary heat transfer surface shall be (mild steel) (400 series stainless steel). The heat exchanger design shall permit unrestricted lateral and peripheral expansion during the heating and cooling cycle. The flue gas travel shall be of four-pass design, with no internal baffles. The surface temperature of the heat exchanger shall not exceed 75% of its scaling temperature when operating at rated capacity. The heat exchanger shall be rated at a minimum of 80% efficiency at rated output. A pressure relief door complete with an observation window to view the flame shall be provided.

## DIRECT DRIVE INDUCED DRAFT FAN

An integrally mounted, heavy duty, non-clogging radial blade induced draft fan complete with direct drive motor shall be provided. The induced draft fan shall be adequately sized to insure proper draft conditions when operating at rated capacity and equipped with a manual damper complete with locking quadrant to ensure proper draft and extended heat exchanger performance.

## BURNER

The gas burner shall be of the power type, complete with integral combustion air blower and motor, combustion air proving switch, and removable pilot assembly. The combustion air damper shall be interlocked with the gas control valve to insure a proper gas/air mixture throughout the complete range of operation. Burner and controls shall be capable of delivering \_\_\_\_\_ MBH output firing on (natural gas) (propane) at an inlet pressure of \_\_\_\_\_ (inches water column) (PSIG) and in accordance with (manufacturer's standard) (FM) (IRI) requirements. Burner and controls shall be arranged for (On-Off) (High/Low/Off) (Full Modulation with low fire start and a \_\_\_\_\_ turndown ratio). The factory wired and piped valve train shall be mounted inside the unit weatherproof enclosure (on IFW models) and be complete with:

- low pressure appliance regulator
- motorized gas control valve
- main manual test firing shut-off valve
- pilot manual shut-off valve
- pilot pressure regulator
- pilot automatic shut-off valve
- pilot manual test firing shut-off valve

# Guide Specifications



## ELECTRICAL CONTROLS

A NEMA 1 control panel complete with hinged access door shall be mounted inside the weatherproof enclosure (on IFW models). All control components are to be labeled and individually wired to a numbered terminal strip to aid in servicing. All wiring shall be color coded and number tagged at each end to match the control diagram supplied. Full operating and maintenance instructions shall accompany each unit. All wiring between the controls and valves shall be run in flexible conduit. All electrical components shall bear the U.L. label. The control system shall include but not be limited to the following components required for automatic operation:

- control circuit transformer
- fan motor starters, overloads and sub-circuit fuses
- control circuit fuses
- control relays
- electronic flame relay complete with alarm contacts
- induced draft fan air proving differential switch
- high limit switch
- automatic/manual fan switch
- heavy duty ignition transformer

## OPTIONAL EQUIPMENT & CONTROLS

1. Motorized inlet air shut-off damper with heavy gauge galvanized steel frame. Blades shall be die formed, triple V-groove 16 gauge galvanized steel, maximum 6" wide. Axles shall be  $\frac{1}{2}$ " plated steel.
2. V-Bank filter section with nominal 2" thick (throwaway) (pleated) (cleanable) filters.
3. Combination filter/mixing section with nominal 2" thick (throwaway) (pleated) (cleanable) filters and motorized mixing dampers with a heavy gauge galvanized steel frame. Blades shall be die formed, triple V-groove 16 gauge galvanized steel, maximum 6" wide. Axles shall be  $\frac{1}{2}$ " plated steel. The damper motor and linkage shall be mounted inside the unit casing.
4. Closure panels
5. Screened inlet section
6. 90° Discharge nozzles for vertical models
7. 45° Discharge nozzles for horizontal models
8. Inlet hood and birdscreen
9. Insulated (blower section) (filter section) (filter/mixing section)
10. Structural base frame for horizontal units
11. Service platform with guardrails for horizontal units
12. Extended lube lines
13. Internal blower/motor isolation
14. High Efficiency blower motor
15. Mild weather shutdown ductstat
16. Clogged filter switch and indicating light.
17. Disconnect switch
18. Painted galvanized casing
19. High gas pressure regulator (shipped loose for inlet pressures over 1 PSIG.
20. Circuit analyzer
21. Remote control panel.
22. Night set back thermostat
23. 7 day time clock
24. Timed freeze protection
25. On-Off night setback thermostat
26. Smoke detector





# Applied Air



## Efficient Indirect Fired Heating Systems

### Choose Applied Air Indirect Gas Fired Systems

- Heat large spaces or warehouses without products of combustion in the supply air
- Mount units indoor, outdoors, or on the roof
- Low operating and maintenance costs
- Simple, inexpensive installation
- Applied Air, a leader in research, engineering, and customer service since 1975

Applied Air

[www.appliedair.com](http://www.appliedair.com)

4830 Transport Drive Dallas TX 75247

Telephone 214.638.6010

Fax 214.905.0806