

# DFM Direct Fired Gas Heating System

**Technical Guide for:**

**Indoor Mounted Units  
To 64,000 CFM  
And 9M BTUH**

**Applied Air**

**Keeps You**

**Warm**



**Applied Air<sup>®</sup>**



**DFM Direct Fired  
Gas Heating System  
Technical Guide**



**Applied Air<sup>®</sup>**

In the business of commercial and industrial operations, efficient and low-cost heating is essential. Applied Air keeps you warm for less.

Since 1975, Applied Air has been providing cost-effective, reliable gas heating solutions. Our proven Direct Fired Gas Heating System adds warm, fresh and clean air to your work environment for greater comfort and productivity.

This Technical Guide will help you choose an Applied Air Direct Fired Gas Heating System to provide efficient, cost-effective heating for your warehouse, factory or process operation. The Guide covers:

- Technical Specifications — Configure the right system components (e.g., burner, motors, drive, filter, options, etc.) to meet your needs.
- Installation Information — Plan details of on-site installation with dimensional information and cabinet arrangement diagrams.

If you have questions, please contact Applied Air's Customer Service Department at 214-638-6010. We'll be glad to help.

To add evaporative cooling, refer to the Applied Air ECS Evaporative Cooling System brochure.

**Applied Air**

**Keeps You**

**Warm**

# Table of Contents



Air Delivery Tables .....	4-5
Burner Performance Table .....	6-7
Dimensions	
Horizontal Units .....	8-9
Vertical Units .....	10-11
Return Air Sections.....	12
Filter Banks .....	13
Inlet Dampers .....	14
Discharge Louvers .....	15
Control Systems .....	16-19
Typical Wiring Diagram .....	20-21
Amp Draw Table .....	22
Sequence of Operation.....	22
Typical Gas Piping Layout .....	23
Cabinet Arrangements .....	24
Unit Weights .....	24
Guide Specification – Basic Unit .....	25
Guide Specification – Mixing Dampers With Return Air Flow System .....	26
Guide Specification – BACview Controller .....	27

# Air Delivery Table

Blower HP Selection										
Unit Model	CFM Std. Air @ 70°	FPM Outlet Velocity	Total External Static Pressure (W.C.)							
			1/4" HP	3/8" HP	1/2" HP	3/4" HP	1" HP	1 1/4" HP	1 1/2" HP	2" HP
109	1600	1914	1	1	1	1	—	—	—	—
	1900	2273	1	1	1 1/2	1 1/2	1 1/2	1 1/2	2	—
	2200	2632	1 1/2	1 1/2	1 1/2	1 1/2	2	2	2	3
	2600	3110	2	2	2	2	3	3	3	3
	3000	3589	3	3	3	3	3	3	3	5
112	3250	2257	1 1/2	2	2	2	2	3	3	3
	3500	2431	2	2	2	2	3	3	3	3
	3750	2604	2	2	3	3	3	3	3	5
	4000	2778	3	3	3	3	3	3	5	5
	4250	2951	3	3	3	3	3	5	5	5
115	4500	2239	2	2	3	3	3	3	5	—
	5000	2488	3	3	3	3	3	5	5	5
	5500	2736	3	3	3	3	5	5	5	5
	6000	2985	3	5	5	5	5	5	5	7 1/2
118	6500	2265	3	5	5	5	5	5	5	7 1/2
	7000	2439	5	5	5	5	5	5	7 1/2	7 1/2
	7500	2613	5	5	5	5	5	7 1/2	7 1/2	7 1/2
	8000	2787	5	5	5	5	7 1/2	7 1/2	7 1/2	7 1/2
	8500	2962	5	5	5	7 1/2	7 1/2	7 1/2	7 1/2	10
120	9000	2143	5	5	5	5	7 1/2	7 1/2	7 1/2	—
	9500	2262	5	5	5	7 1/2	7 1/2	7 1/2	7 1/2	—
	10,000	2381	5	5	5	7 1/2	7 1/2	7 1/2	7 1/2	10
	10,500	2500	5	7 1/2	7 1/2	7 1/2	7 1/2	7 1/2	10	10
	11,000	2619	7 1/2	7 1/2	7 1/2	7 1/2	7 1/2	10	10	10
122	11,000	2157	5	5	7 1/2	7 1/2	7 1/2	7 1/2	10	—
	12,000	2353	7 1/2	7 1/2	7 1/2	7 1/2	7 1/2	10	10	15
	13,000	2549	7 1/2	7 1/2	7 1/2	10	10	10	10	15
	14,000	2745	7 1/2	10	10	10	10	15	15	15
	15,000	2941	—	10	10	10	15	15	15	15
125	14,000	2086	7 1/2	7 1/2	7 1/2	7 1/2	10	—	—	—
	15,000	2235	7 1/2	7 1/2	7 1/2	10	10	10	15	—
	16,000	2385	7 1/2	7 1/2	7 1/2	10	10	15	15	—
	18,000	2683	10	10	10	10	15	15	15	15
	20,000	2981	15	15	15	15	15	15	15	20
130	22,000	2486	10	10	10	15	15	15	15	—
	24,000	2581	10	15	15	15	15	15	20	20
	26,000	2796	15	15	15	15	20	20	20	25
	28,000	3011	15	15	15	20	20	20	20	25
	30,000	3226	20	20	20	20	20	25	25	30

**NOTE:**

The horsepower selections are based on system external static pressure. One or more of the following must be added when applicable.

- A. Motor Operated Inlet Damper .13" W.C.
- B. V-Bank Filter Section .25" W.C.
- C. Discharge Louver .13" W.C.

**SELECTION GUIDE**

1. Determine the required amount of replacement air (CFM) by computing the total amount of air being exhausted. (Restaurants should be sized for 90% of exhaust air to minimize food odors.)
2. Determine the total external static pressure by adding the pressure drops through all accessories and ducts.
3. Select unit sizes and motor horsepower from table.

# Air Delivery Table

Blower HP Selection										
Unit Model	CFM Std. Air @ 70°	FPM Outlet Velocity	Total External Static Pressure (W.C.)							
			1/4" HP	3/8" HP	1/2" HP	3/4" HP	1" HP	1 1/4" HP	1 1/2" HP	2" HP
215	9000	2239	5	5	5	5	5	—	—	—
	9500	2363	5	5	5	5	7 1/2	7 1/2	—	—
	10,000	2488	5	5	5	7 1/2	7 1/2	7 1/2	7 1/2	—
	10,500	2612	5	5	7 1/2	7 1/2	7 1/2	7 1/2	7 1/2	—
	11,000	2736	5	7 1/2	7 1/2	7 1/2	7 1/2	7 1/2	10	10
	11,500	2861	7 1/2	7 1/2	7 1/2	7 1/2	7 1/2	10	10	10
	12,000	2985	7 1/2	7 1/2	7 1/2	7 1/2	10	10	10	15
218	12,500	2178	7 1/2	7 1/2	7 1/2	7 1/2	7 1/2	—	—	—
	13,000	2265	7 1/2	7 1/2	7 1/2	7 1/2	10	10	—	—
	14,000	2439	7 1/2	7 1/2	7 1/2	10	10	10	15	—
	15,000	2613	7 1/2	10	10	10	10	15	15	15
	16,000	2787	10	10	10	10	15	15	15	15
	17,000	2962	10	10	10	15	15	15	15	20
220	18,000	2143	7 1/2	10	10	10	15	15	15	—
	19,000	2262	10	10	10	10	15	15	15	—
	20,000	2381	10	10	10	15	15	15	15	20
	21,000	2500	10	15	15	15	15	15	20	20
	22,000	2619	15	15	15	15	15	15	20	20
	23,000	2738	15	15	15	15	15	20	20	20
	24,000	2857	15	15	15	15	20	20	20	25
	25,000	2976	15	15	15	20	20	20	20	25
26,000	3095	15	20	20	20	20	20	25	25	
222	25,000	2451	15	15	15	15	20	20	20	25
	26,000	2549	15	15	15	20	20	20	20	25
	27,000	2647	15	15	15	20	20	20	25	25
	28,000	2745	15	20	20	20	20	25	25	30
	29,000	2843	20	20	20	20	25	25	25	30
	30,000	2941	20	20	20	20	25	25	25	30
	31,000	3039	20	20	20	25	25	25	30	30
225	30,000	2235	15	15	15	15	20	20	—	—
	32,000	2385	15	15	15	20	20	25	25	—
	34,000	2534	15	20	20	20	20	25	25	30
	36,000	2683	20	20	20	20	25	25	30	30
	38,000	2832	20	20	20	25	25	30	30	40
	40,000	2981	20	25	25	25	30	30	30	40
	42,000	3130	25	25	25	30	30	30	40	40
	44,000	3279	25	30	30	30	40	40	40	40
	46,000	3428	30	30	30	40	40	40	40	50
230	44,000	2366	20	20	20	25	25	30	—	—
	48,000	2581	20	25	25	25	30	30	40	—
	52,000	2796	25	25	30	30	40	40	40	50
	56,000	3011	30	30	30	40	40	40	40	50
	60,000	3226	40	40	40	40	40	50	50	50
	64,000	3441	40	40	40	50	50	50	50	60

# Burner Performance Table

Single Blower Models								
Unit Model	CFM Std. Air @ 70°	70° RISE	80° RISE	90° RISE	100° RISE	110° RISE	120° RISE	130° RISE
109	1600	142	159	175	191	206	221	235
	1900	169	189	208	227	245	262	279
	2200	195	219	241	263	284	304	323
	2600	231	258	285	311	335	359	382
	3000	266	298	329	358	387	414	440
112	3250	288	323	356	388	419	449	477
	3500	311	348	384	418	451	483	514
	3750	333	373	411	448	483	518	550
	4000	355	397	438	478	516	552	587
	4250	377	422	466	508	548	587	624
115	4500	399	447	493	537	580	621	661
	5000	444	497	548	597	644	690	734
	5500	488	546	603	657	709	759	807
	6000	532	596	658	717	773	828	881
118	6500	577	646	712	776	838	897	954
	7000	621	696	767	836	902	966	1027
	7500	665	745	822	896	967	1035	1101
	8000	710	795	877	955	1031	1104	1174
	8500	754	845	932	1015	1096	11733	1248
120	9000	798	894	986	1075	1160	1242	1321
	9500	843	944	1041	1135	1224	1311	1394
	10,000	887	994	1096	1194	1289	1380	1468
	10,500	932	1043	1151	1254	1353	1449	1541
	11,000	976	1093	1205	1314	1418	1518	1615
122	11,000	976	1093	1205	1314	1418	1518	1615
	12,000	1065	1192	1315	1433	1547	1656	1761
	13,000	1153	1292	1425	1553	1676	1794	1908
	14,000	1242	1391	1534	1672	1804	1932	2055
	15,000	1331	1490	1644	1791	1933	2070	2202
125	14,000	1242	1391	1534	1672	1804	1932	2055
	15,000	1331	1490	1644	1791	1933	2070	2202
	16,000	1419	1590	1753	1911	2062	2208	2349
	17,000	1508	1689	1863	2030	2191	2346	2495
	18,000	1597	1788	1973	2150	2320	2484	2642
	20,000	1774	1987	2192	2388	2578	2760	2936
130	22,000	1952	2186	2411	2627	2836	3036	3229
	24,000	2129	2385	2630	2866	3093	3312	3523
	26,000	2307	2583	2849	3105	3351	3588	3816
	28,000	2484	2782	3069	3344	3609	3864	4110
	30,000	2661	2981	3288	3583	3867	4140	4404

## SELECTION GUIDE

- Determine the temperature rise required through the heater by subtracting the winter design temperature from the desired indoor temperature.
- Select burner required.  

$$BTUH = \frac{SCFM \times 1.32605 \times 29.92 \times 0.24 \times 60 \times \text{Temperature Rise}}{.92 (460 + \text{Temperature Rise} + \text{Inlet Temperature})}$$

where 1.32605 = density of air handled by the blower  
 29.92 = barometric pressure at sea level  
 0.24 = specific heat of the air handled by the blower  
 60 = conversion for minutes to hour  
 0.92 = average ratio of net and gross heating values of common fuel gases (92% sensible, 8% latent)
- Values shown in above MBH Input Tables are based on -40° F Inlet Temperature. MBH input shown on unit rating plate will be corrected for actual air density.
- Natural gas units are limited to 130° F temperature rise, propane units are limited to 100° F temperature rise.

# Burner Performance Table

Twin Blower Models								
Unit Model	CFM Std. Air @ 70°	70° RISE	80° RISE	90° RISE	100° RISE	110° RISE	120° RISE	130° RISE
215	9000	798	894	986	1075	1160	1242	1321
	9500	843	944	1041	1135	1224	1311	1394
	10,000	887	994	1096	1194	1289	1380	1468
	10,500	932	1043	1151	1254	1353	1449	1541
	11,000	976	1093	1205	1314	1418	1518	1615
	11,500	1020	1143	1260	1373	1482	1587	1688
	12,000	1065	1192	1315	1433	1547	1656	1761
218	13,000	1153	1292	1425	1553	1676	1794	1908
	14,000	1242	1391	1534	1672	1804	1932	2055
	15,000	1331	1490	1644	1791	1933	2070	2202
	16,000	1419	1590	1753	1911	2062	2208	2349
	17,000	1508	1689	1863	2030	2191	2346	2495
220	18,000	1597	1788	1973	2105	2320	2484	2642
	19,000	1686	1888	2082	2269	2449	2622	2789
	20,000	1774	1987	2192	2388	2578	2760	2936
	21,000	1863	2087	2301	2508	2707	2898	3082
	22,000	1952	2186	2411	2627	2836	3036	3229
	23,000	2040	2285	2521	2747	2964	3174	3376
	24,000	2129	2385	2630	2866	3093	3312	3523
	25,000	2218	2484	2740	2986	3222	3450	3670
26,000	2307	2583	2849	3105	3351	3588	3816	
222	25,000	2218	2484	2740	2986	3222	3450	3670
	26,000	2307	2583	2849	3105	3351	3588	3816
	27,000	2395	2683	2959	3224	3480	3726	3963
	28,000	2484	2782	3069	3344	3609	3864	4110
	29,000	2573	2881	3178	3463	3738	4002	4257
	30,000	2661	2981	3288	3583	3867	4140	4404
	31,000	2750	3080	3397	3702	3996	4278	4550
225	30,000	2661	2981	3288	3583	3867	4140	4404
	32,000	2839	3180	3507	3822	4124	4416	4697
	34,000	3016	3378	3726	4060	4382	4692	4991
	36,000	3194	3577	3945	4299	4640	4968	5284
	38,000	3371	3776	4164	4538	4898	5244	5578
	40,000	3549	3974	4384	4777	5156	5520	5871
	42,000	3726	4173	4603	5016	5413	5796	6165
	44,000	3903	4372	4822	5255	5671	6072	6458
	46,000	4081	4571	5041	5494	5929	6348	6752
230	44,000	3903	4372	4822	5255	5671	6072	6458
	48,000	4258	4769	5260	5732	6187	6624	7046
	52,000	4613	5167	5699	6210	6702	7176	7633
	56,000	4968	5564	6137	6688	7218	7728	8220
	60,000	5323	5962	6575	7165	7733	8280	8807
	64,000	5678	6359	7014	7643	8249	8832	9394

# Dimensions

## Single Blower Models – Horizontal Units

C000498A

### UNIT COMPONENTS

- |                                |                               |                                      |   |
|--------------------------------|-------------------------------|--------------------------------------|---|
| 1. Inlet Damper                | 5. R/A section (after burner) | 9. Control cabinet                   | 13. Return air damper   |
| 2. R/A section (before burner) | 6. Blower section             | 10. Access door (piping compartment) | 14. Belt guard  |
| 3. V-bank                      | 7. Filter access              | 11. Gas piping manifold              | 15. Return air flow station<br>(required for ETL listed<br>Return Air Unit) |
| 4. Burner section              | 8. Adjustable profile         | 12. R/A access                       |   |

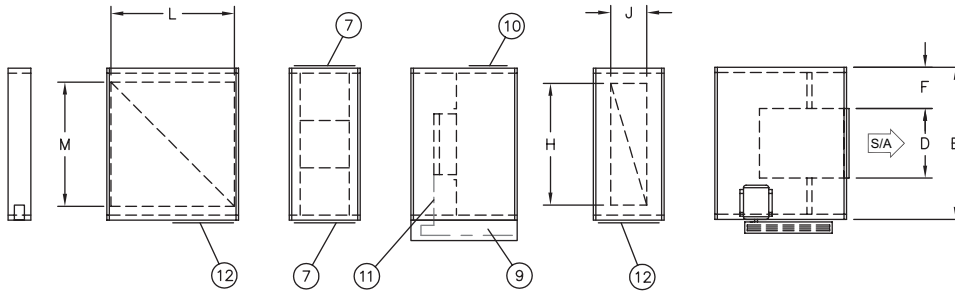

**PLAN VIEW**

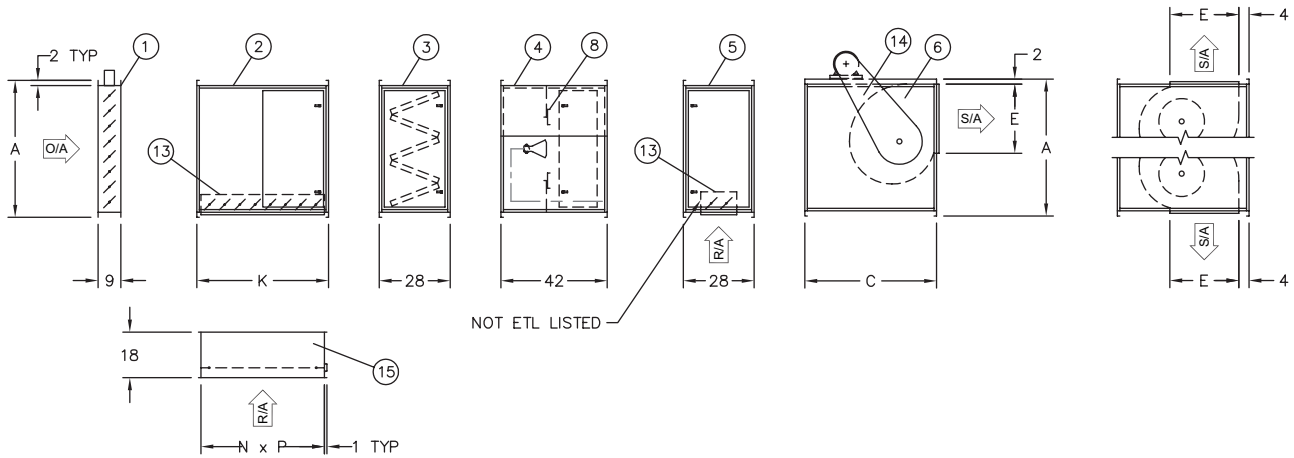

**FRONT VIEW**

Model	Dimensions												
	A	B	C	D	E	F	H	J	K	L	M	N	P
109	29	45	33	12	10 <sup>1</sup> / <sub>2</sub>	16 <sup>1</sup> / <sub>2</sub>	30	8 <sup>1</sup> / <sub>4</sub>	28	23 <sup>3</sup> / <sub>4</sub>	34	25 <sup>1</sup> / <sub>8</sub>	34 <sup>1</sup> / <sub>2</sub>
112	29	45	33	15 <sup>3</sup> / <sub>4</sub>	13 <sup>3</sup> / <sub>8</sub>	14 <sup>5</sup> / <sub>8</sub>	30	8 <sup>1</sup> / <sub>4</sub>	28	23 <sup>3</sup> / <sub>4</sub>	34	25 <sup>1</sup> / <sub>8</sub>	34 <sup>1</sup> / <sub>2</sub>
115	37 <sup>1</sup> / <sub>4</sub>	51	43	18 <sup>3</sup> / <sub>4</sub>	16	16 <sup>1</sup> / <sub>8</sub>	30	14 <sup>1</sup> / <sub>4</sub>	43	39 <sup>3</sup> / <sub>4</sub>	40	40 <sup>1</sup> / <sub>4</sub>	40 <sup>1</sup> / <sub>2</sub>
118	37 <sup>1</sup> / <sub>4</sub>	51	43	22	19	14 <sup>1</sup> / <sub>2</sub>	30	14 <sup>1</sup> / <sub>4</sub>	43	39 <sup>3</sup> / <sub>4</sub>	40	40 <sup>1</sup> / <sub>4</sub>	40 <sup>1</sup> / <sub>2</sub>
120	54	60	52	24 <sup>7</sup> / <sub>8</sub>	24 <sup>7</sup> / <sub>8</sub>	17 <sup>9</sup> / <sub>16</sub>	48	14 <sup>1</sup> / <sub>4</sub>	52	48 <sup>3</sup> / <sub>4</sub>	49	49 <sup>1</sup> / <sub>8</sub>	49 <sup>1</sup> / <sub>2</sub>
122	54	60	52	27 <sup>3</sup> / <sub>8</sub>	27 <sup>3</sup> / <sub>8</sub>	16 <sup>5</sup> / <sub>16</sub>	48	14 <sup>1</sup> / <sub>4</sub>	52	48 <sup>3</sup> / <sub>4</sub>	49	49 <sup>1</sup> / <sub>8</sub>	49 <sup>1</sup> / <sub>2</sub>
125	66	72	60	31 <sup>3</sup> / <sub>8</sub>	31 <sup>3</sup> / <sub>8</sub>	20 <sup>5</sup> / <sub>16</sub>	60	20 <sup>1</sup> / <sub>4</sub>	52	48 <sup>3</sup> / <sub>4</sub>	61	49 <sup>1</sup> / <sub>8</sub>	61 <sup>1</sup> / <sub>2</sub>
130	66	72	60	36 <sup>7</sup> / <sub>8</sub>	36 <sup>7</sup> / <sub>8</sub>	17 <sup>9</sup> / <sub>16</sub>	60	20 <sup>1</sup> / <sub>4</sub>	52	48 <sup>3</sup> / <sub>4</sub>	61	49 <sup>1</sup> / <sub>8</sub>	61 <sup>1</sup> / <sub>2</sub>

**NOTE:** All dimensions in inches subject to manufacturing tolerances.

# Dimensions

## Twin Blower Models – Horizontal Units

C000497A

### UNIT COMPONENTS

- |                                |                               |                                      |   |
|--------------------------------|-------------------------------|--------------------------------------|---|
| 1. Inlet damper                | 5. R/A section (after burner) | 9. Control cabinet                   | 13. Return air damper   |
| 2. R/A section (before burner) | 6. Blower section             | 10. Access door (piping compartment) | 14. Belt guard  |
| 3. V-bank                      | 7. Filter access              | 11. Gas piping manifold              | 15. Return air flow station<br>(Required for ETL listed<br>Return Air Unit) |
| 4. Burner section              | 8. Adjustable profile         | 12. R/A access                       |   |

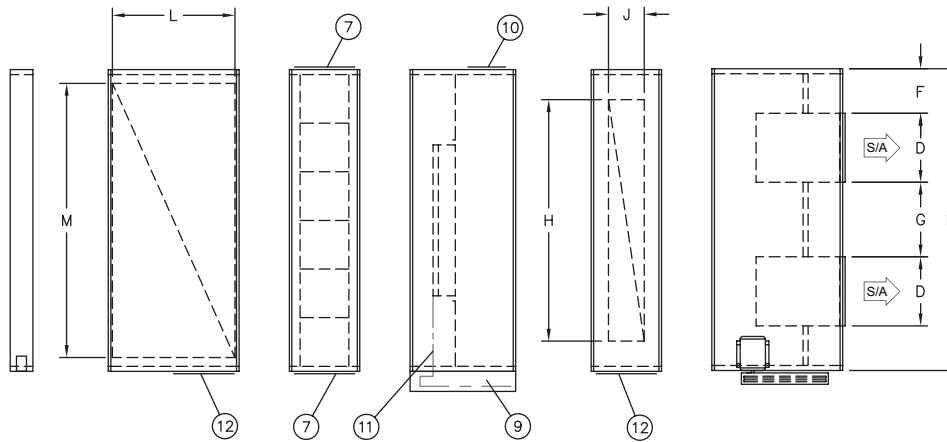

**PLAN VIEW**

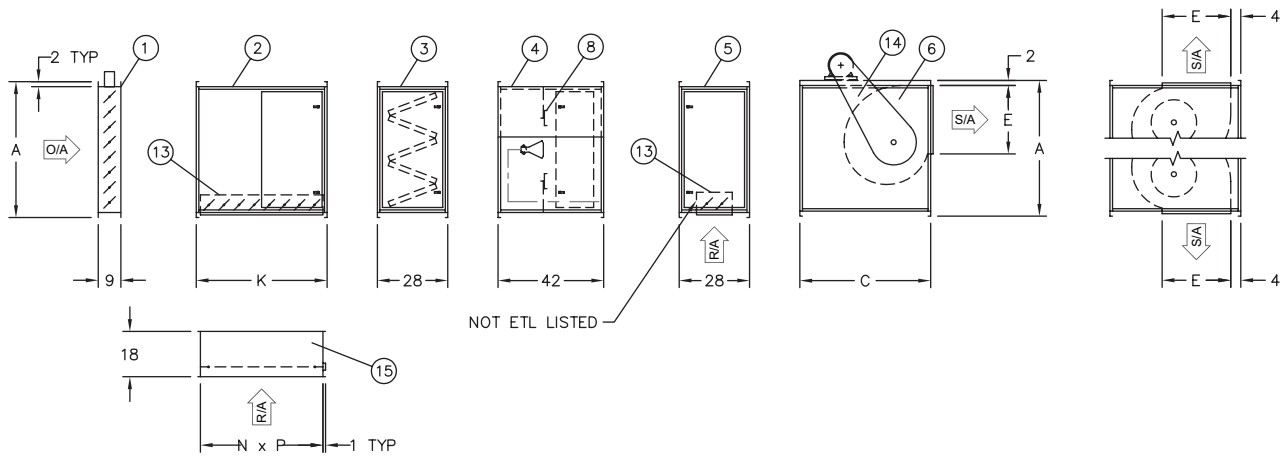

**FRONT VIEW**

Model	Dimensions													
	A	B	C	D	E	F	G	H	J	K	L	M	N	P
215	37 <sup>1</sup> / <sub>4</sub>	93	43	18 <sup>3</sup> / <sub>4</sub>	16	16 <sup>1</sup> / <sub>8</sub>	22 <sup>1</sup> / <sub>2</sub>	79	10	43	39 <sup>3</sup> / <sub>4</sub>	82	40 <sup>1</sup> / <sub>4</sub>	82 <sup>1</sup> / <sub>2</sub>
218	37 <sup>1</sup> / <sub>4</sub>	93	43	22	19	13 <sup>1</sup> / <sub>4</sub>	22 <sup>1</sup> / <sub>2</sub>	79	10	43	39 <sup>3</sup> / <sub>4</sub>	82	40 <sup>1</sup> / <sub>4</sub>	82 <sup>1</sup> / <sub>2</sub>
220	54	120	52	24 <sup>7</sup> / <sub>8</sub>	24 <sup>7</sup> / <sub>8</sub>	20 <sup>1</sup> / <sub>4</sub>	29 <sup>5</sup> / <sub>8</sub>	96	14 <sup>1</sup> / <sub>4</sub>	52	48 <sup>3</sup> / <sub>4</sub>	109	49 <sup>1</sup> / <sub>8</sub>	109 <sup>1</sup> / <sub>2</sub>
222	54	120	52	27 <sup>3</sup> / <sub>8</sub>	27 <sup>3</sup> / <sub>8</sub>	17 <sup>3</sup> / <sub>4</sub>	29 <sup>5</sup> / <sub>8</sub>	96	14 <sup>1</sup> / <sub>4</sub>	52	48 <sup>3</sup> / <sub>4</sub>	109	49 <sup>1</sup> / <sub>8</sub>	109 <sup>1</sup> / <sub>2</sub>
225	66	144	60	31 <sup>3</sup> / <sub>8</sub>	31 <sup>3</sup> / <sub>8</sub>	21 <sup>3</sup> / <sub>4</sub>	37 <sup>5</sup> / <sub>8</sub>	120	20 <sup>1</sup> / <sub>4</sub>	52	48 <sup>3</sup> / <sub>4</sub>	133	49 <sup>1</sup> / <sub>8</sub>	133 <sup>3</sup> / <sub>8</sub>
230	66	144	60	36 <sup>7</sup> / <sub>8</sub>	36 <sup>7</sup> / <sub>8</sub>	18 <sup>5</sup> / <sub>8</sub>	33	120	20 <sup>1</sup> / <sub>4</sub>	52	48 <sup>3</sup> / <sub>4</sub>	133	49 <sup>1</sup> / <sub>8</sub>	133 <sup>3</sup> / <sub>8</sub>

**NOTE:** All dimensions in inches subject to manufacturing tolerances.

# Dimensions

## Single Blower Models – Vertical Units

C000500A

### UNIT COMPONENTS

- |                                |                       |                         |   |
|--------------------------------|-----------------------|-------------------------|---|
| 1. Inlet Damper                | 6. Blower section     | 11. Gas piping manifold | 15. Return air flow station<br>(Required for ETL listed<br>Return Air Unit) |
| 2. R/A section (before burner) | 7. Filter access      | 12. R/A access          | 16. Screen  |
| 3. V-bank                      | 8. Adjustable profile | 13. Return air damper   |   |
| 4. Burner section              | 9. Control cabinet    | 14. Belt guard          |   |
| 5. R/A section (after burner)  | 10. Access door       |                         |   |

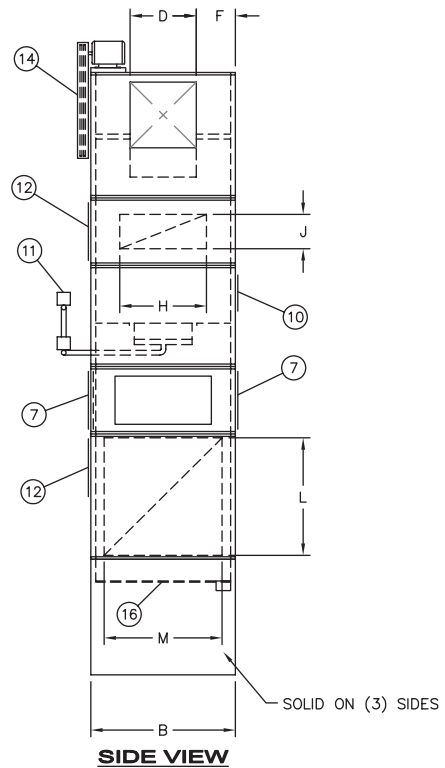
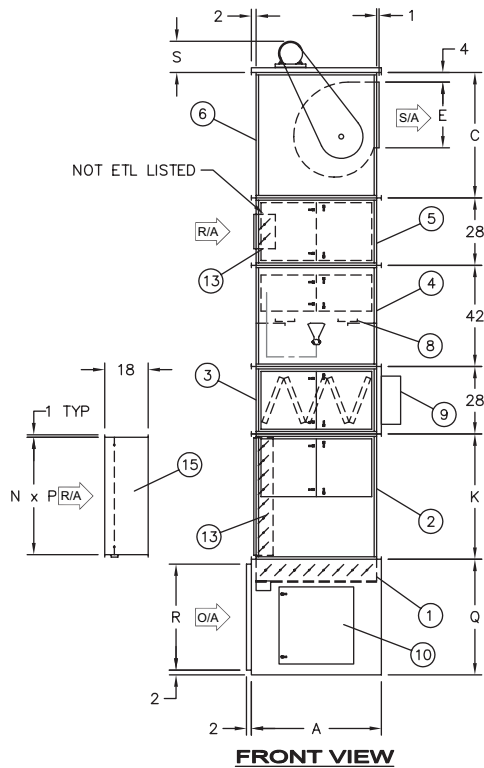
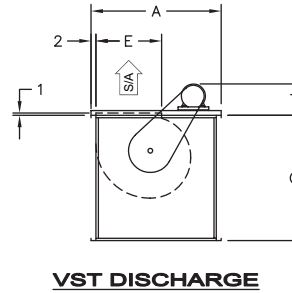
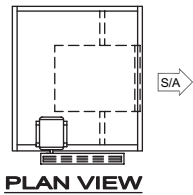

Model	Dimensions															
	A	B	C	D	E	F	H	J	K	L	M	N	P	Q	R	S
109	29	45	33	12	10 <sup>1</sup> / <sub>2</sub>	16 <sup>1</sup> / <sub>2</sub>	30	8 <sup>1</sup> / <sub>4</sub>	28	23 <sup>3</sup> / <sub>4</sub>	34	25 <sup>1</sup> / <sub>8</sub>	34 <sup>1</sup> / <sub>2</sub>	36	32	17 <sup>1</sup> / <sub>4</sub>
112	29	45	33	15 <sup>3</sup> / <sub>4</sub>	13 <sup>3</sup> / <sub>8</sub>	14 <sup>5</sup> / <sub>8</sub>	30	8 <sup>1</sup> / <sub>4</sub>	28	23 <sup>3</sup> / <sub>4</sub>	34	25 <sup>1</sup> / <sub>8</sub>	34 <sup>1</sup> / <sub>2</sub>	36	32	17 <sup>1</sup> / <sub>4</sub>
115	37 <sup>1</sup> / <sub>4</sub>	51	43	18 <sup>3</sup> / <sub>4</sub>	16	16 <sup>1</sup> / <sub>8</sub>	30	14 <sup>1</sup> / <sub>4</sub>	43	39 <sup>3</sup> / <sub>4</sub>	40	40 <sup>1</sup> / <sub>4</sub>	40 <sup>1</sup> / <sub>2</sub>	36	32	17 <sup>1</sup> / <sub>4</sub>
118	37 <sup>1</sup> / <sub>4</sub>	51	43	22	19	14 <sup>1</sup> / <sub>2</sub>	30	14 <sup>1</sup> / <sub>4</sub>	43	39 <sup>3</sup> / <sub>4</sub>	40	40 <sup>1</sup> / <sub>4</sub>	40 <sup>1</sup> / <sub>2</sub>	36	32	20
120	54	60	52	24 <sup>7</sup> / <sub>8</sub>	24 <sup>7</sup> / <sub>8</sub>	17 <sup>9</sup> / <sub>16</sub>	48	14 <sup>1</sup> / <sub>4</sub>	52	48 <sup>3</sup> / <sub>4</sub>	49	49 <sup>1</sup> / <sub>8</sub>	49 <sup>1</sup> / <sub>2</sub>	48	44	20
122	54	60	52	27 <sup>3</sup> / <sub>8</sub>	27 <sup>3</sup> / <sub>8</sub>	16 <sup>5</sup> / <sub>16</sub>	48	14 <sup>1</sup> / <sub>4</sub>	52	48 <sup>3</sup> / <sub>4</sub>	49	49 <sup>1</sup> / <sub>8</sub>	49 <sup>1</sup> / <sub>2</sub>	48	44	20
125	66	72	60	31 <sup>3</sup> / <sub>8</sub>	31 <sup>3</sup> / <sub>8</sub>	20 <sup>5</sup> / <sub>16</sub>	60	20 <sup>1</sup> / <sub>4</sub>	52	48 <sup>3</sup> / <sub>4</sub>	61	49 <sup>1</sup> / <sub>8</sub>	61 <sup>1</sup> / <sub>2</sub>	48	44	21
130	66	72	60	36 <sup>7</sup> / <sub>8</sub>	36 <sup>7</sup> / <sub>8</sub>	17 <sup>9</sup> / <sub>16</sub>	60	20 <sup>1</sup> / <sub>4</sub>	52	48 <sup>3</sup> / <sub>4</sub>	61	49 <sup>1</sup> / <sub>8</sub>	61 <sup>1</sup> / <sub>2</sub>	48	44	21

**NOTE:** All dimensions in inches subject to manufacturing tolerances.

# Dimensions

## Twin Blower Models – Vertical Units

C000499A

### UNIT COMPONENTS

- |                                |                       |                         |   |
|--------------------------------|-----------------------|-------------------------|---|
| 1. Inlet damper                | 6. Blower section     | 11. Gas piping manifold | 15. Return air flow station<br>(Required for ETL listed<br>Return Air Unit) |
| 2. R/A section (before burner) | 7. Filter access      | 12. R/A access          | 16. Screen  |
| 3. V-bank                      | 8. Adjustable profile | 13. R/A air damper      |   |
| 4. Burner section              | 9. Control cabinet    | 14. Belt guard          |   |
| 5. R/A section (after burner)  | 10. Access door       |                         |   |

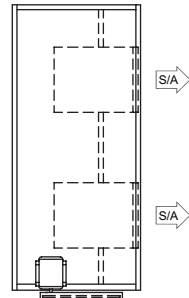

**PLAN VIEW**

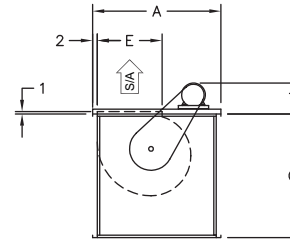

**VST DISCHARGE**

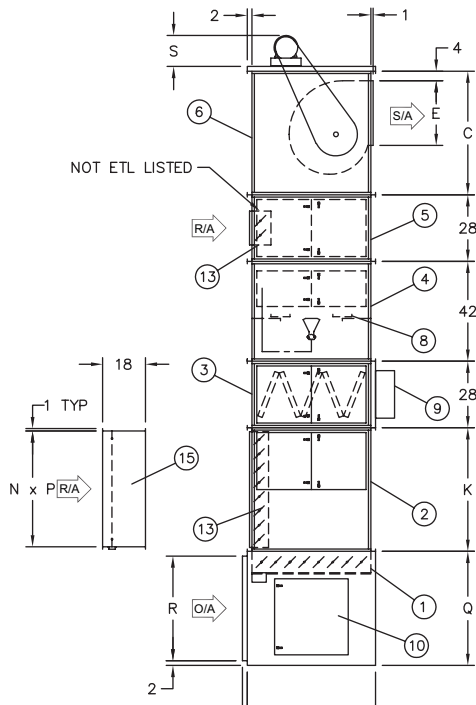

**FRONT VIEW**

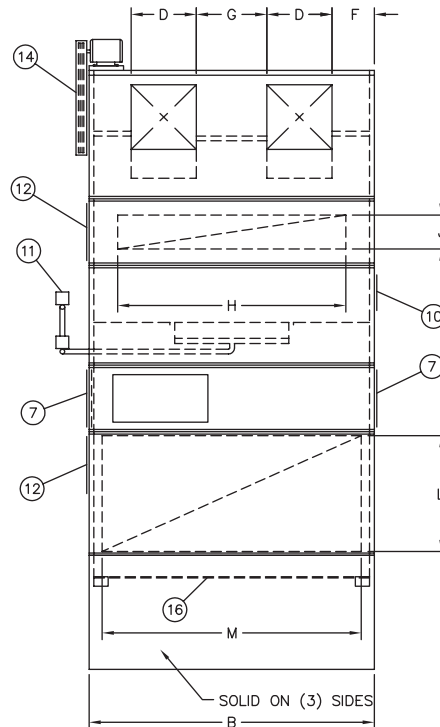

**SIDE VIEW**

Model	Dimensions																
	A	B	C	D	E	F	G	H	J	K	L	M	N	P	Q	R	S
215	37 <sup>1</sup> / <sub>4</sub>	93	43	18 <sup>3</sup> / <sub>4</sub>	16	16 <sup>1</sup> / <sub>8</sub>	22 <sup>1</sup> / <sub>2</sub>	79	10	43	39 <sup>3</sup> / <sub>4</sub>	82	40 <sup>1</sup> / <sub>4</sub>	82 <sup>1</sup> / <sub>2</sub>	36	32	18 <sup>1</sup> / <sub>2</sub>
218	37 <sup>1</sup> / <sub>4</sub>	93	43	22	19	13 <sup>1</sup> / <sub>4</sub>	22 <sup>1</sup> / <sub>2</sub>	79	10	43	39 <sup>3</sup> / <sub>4</sub>	82	40 <sup>1</sup> / <sub>4</sub>	82 <sup>1</sup> / <sub>2</sub>	36	32	22
220	54	120	52	24 <sup>7</sup> / <sub>8</sub>	24 <sup>7</sup> / <sub>8</sub>	20 <sup>1</sup> / <sub>4</sub>	29 <sup>5</sup> / <sub>8</sub>	96	14 <sup>1</sup> / <sub>4</sub>	52	48 <sup>3</sup> / <sub>4</sub>	109	49 <sup>1</sup> / <sub>8</sub>	109 <sup>1</sup> / <sub>2</sub>	48	44	22
222	54	120	52	27 <sup>3</sup> / <sub>8</sub>	27 <sup>3</sup> / <sub>8</sub>	17 <sup>3</sup> / <sub>4</sub>	29 <sup>5</sup> / <sub>8</sub>	96	14 <sup>1</sup> / <sub>4</sub>	52	48 <sup>3</sup> / <sub>4</sub>	109	49 <sup>1</sup> / <sub>8</sub>	109 <sup>1</sup> / <sub>2</sub>	48	44	23 <sup>1</sup> / <sub>2</sub>
225	66	144	60	31 <sup>3</sup> / <sub>8</sub>	31 <sup>3</sup> / <sub>8</sub>	21 <sup>3</sup> / <sub>4</sub>	37 <sup>5</sup> / <sub>8</sub>	120	20 <sup>1</sup> / <sub>4</sub>	52	48 <sup>3</sup> / <sub>4</sub>	133	49 <sup>1</sup> / <sub>8</sub>	133 <sup>3</sup> / <sub>8</sub>	48	44	32 <sup>3</sup> / <sub>4</sub>
230	66	144	60	36 <sup>7</sup> / <sub>8</sub>	36 <sup>7</sup> / <sub>8</sub>	18 <sup>5</sup> / <sub>8</sub>	33	120	20 <sup>1</sup> / <sub>4</sub>	52	48 <sup>3</sup> / <sub>4</sub>	133	49 <sup>1</sup> / <sub>8</sub>	133 <sup>3</sup> / <sub>8</sub>	48	44	32 <sup>3</sup> / <sub>4</sub>

**NOTE:** All dimensions in inches subject to manufacturing tolerances.

# Dimensions

## Return Air Section

C000503

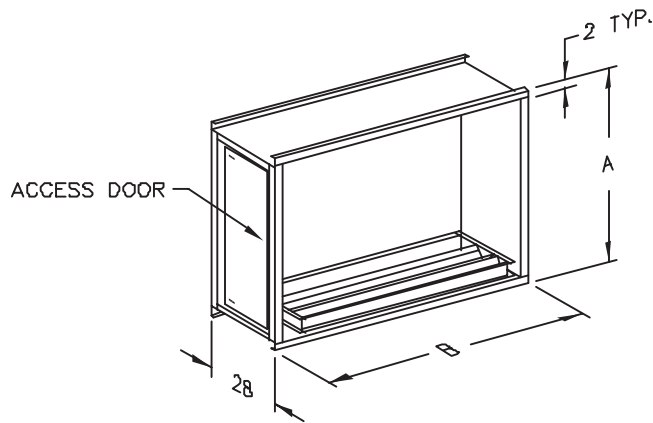

**RETURN AIR**  
(AFTER BURNER SECTION)

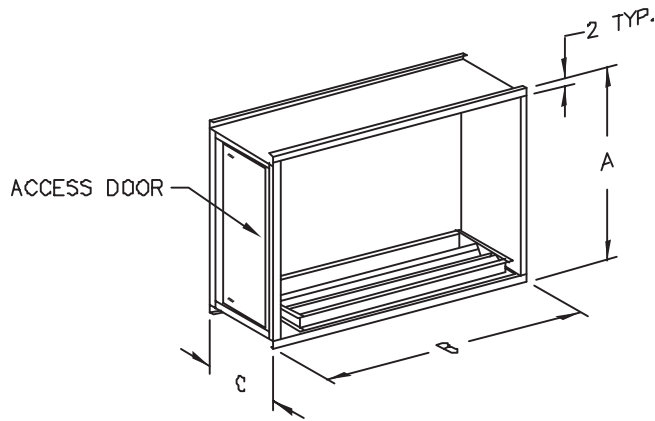

**RETURN AIR**  
(BEFORE BURNER SECTION)

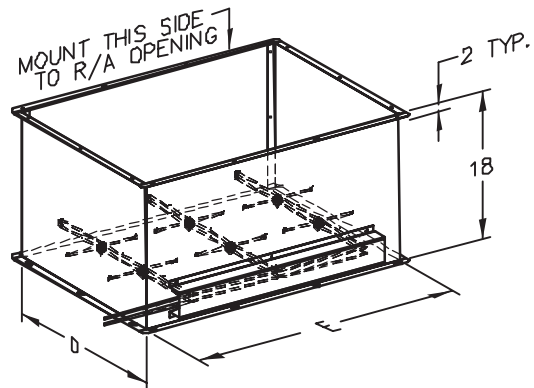

**RETURN AIR FLOW STATION**

Dimension	MODEL								
	109-112	115-118	120-122	125-130	215-218	220-222	225-230		
A	29	37 <sup>1</sup> / <sub>4</sub>	54	66	37 <sup>1</sup> / <sub>4</sub>	54	66		
B	45	51	60	72	93	120	144		
C	28	43	52	52	43	52	52		
D	25 <sup>1</sup> / <sub>8</sub>	40 <sup>1</sup> / <sub>4</sub>	49 <sup>1</sup> / <sub>8</sub>	49 <sup>1</sup> / <sub>8</sub>	40 <sup>1</sup> / <sub>4</sub>	49 <sup>1</sup> / <sub>8</sub>	49 <sup>1</sup> / <sub>8</sub>		
E	34 <sup>1</sup> / <sub>2</sub>	40 <sup>1</sup> / <sub>2</sub>	49 <sup>1</sup> / <sub>2</sub>	61 <sup>1</sup> / <sub>2</sub>	82 <sup>1</sup> / <sub>2</sub>	109 <sup>1</sup> / <sub>2</sub>	133 <sup>3</sup> / <sub>8</sub>		
Model		109-112	115-118	120-122	125-130	215-218	220-222	225-230	
R/A Opening Size		Before Burner	24 <sup>3</sup> / <sub>4</sub> X 34	39 <sup>3</sup> / <sub>4</sub> X 40	48 <sup>3</sup> / <sub>4</sub> X 49	48 <sup>3</sup> / <sub>4</sub> X 61	39 <sup>3</sup> / <sub>4</sub> X 82	48 <sup>3</sup> / <sub>4</sub> X 109	48 <sup>3</sup> / <sub>4</sub> X 133
		After Burner	8 <sup>1</sup> / <sub>4</sub> X 30	14 <sup>1</sup> / <sub>4</sub> X 30	14 <sup>1</sup> / <sub>4</sub> X 48	20 <sup>1</sup> / <sub>4</sub> X 60	10 X 79	14 <sup>1</sup> / <sub>4</sub> X 96	20 <sup>1</sup> / <sub>4</sub> X 120

**NOTE:** R/A openings shall be centered on floor.

**NOTE:** All dimensions in inches subject to manufacturing tolerances.

# Filter Dimensions

C000502

## V-Bank Filter and Filter Information

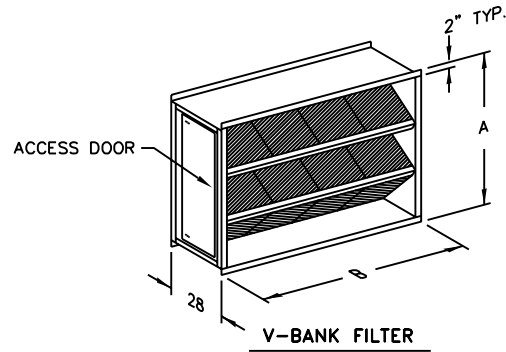

Dimension	MODEL						
	109-112	115-118	120-122	125-130	215-218	220-222	225-230
A	29	37 <sup>1</sup> / <sub>4</sub>	54	66	37 <sup>1</sup> / <sub>4</sub>	54	66
B	45	51	60	72	93	120	144
<b>Model</b>	<b>109-112</b>	<b>115-118</b>	<b>120-122</b>	<b>125-130</b>	<b>215-218</b>	<b>220-222</b>	<b>225-230</b>
<b>V-Bank Filter Qty. &amp; Size</b>	(4) 20 x 20 x 2	(9) 16 x 20 x 2	(10) 20 x 25 x 2	(24) 16 x 20 x 2	(18) 15 x 20 x 2	(35) 16 x 20 x 2	(42) 20 x 20 x 2

**NOTE:** All dimensions in inches subject to manufacturing tolerances.

# Dimensions

## Inlet Damper

C000501A

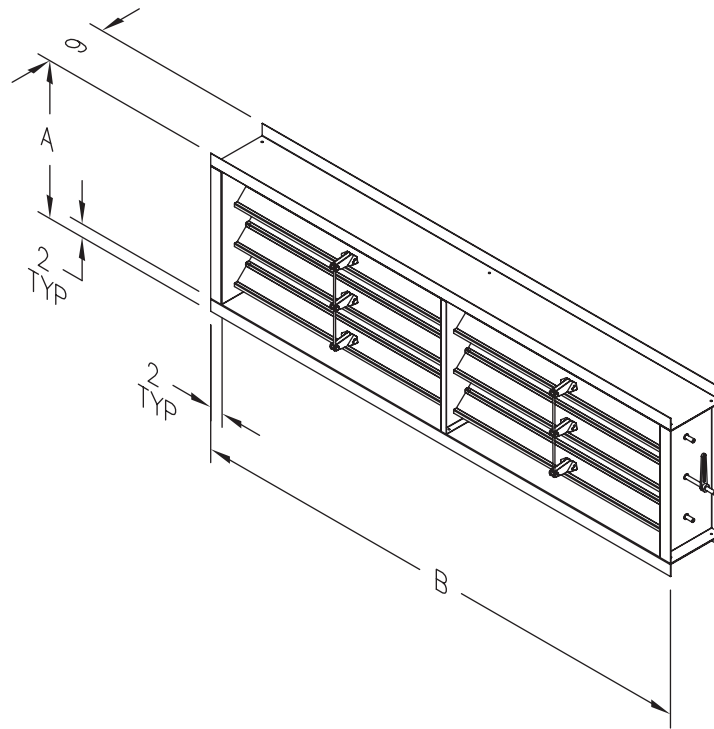

INLET DAMPER

Dimension	Model						
	109-112	115-118	120-122	125-130	215-218	220-222	225-230
A	29	37 <sup>1</sup> / <sub>4</sub>	54	66	37 <sup>1</sup> / <sub>4</sub>	54	66
B	45	51	60	72	93	120	144

**NOTE:** All dimensions in inches subject to manufacturing tolerances.

# Dimensions

## Discharge Louvers

C000501A

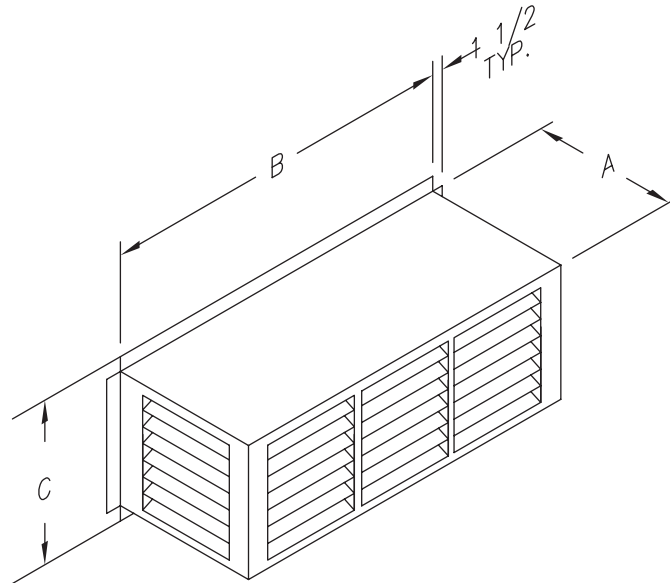

**SIDE INLET  
DISCHARGE LOUVER**

Dimension	Model						
	109-112	115-118	120-122	125-130	215-218	220-222	225-230
A	21	24	45	45	25 <sup>7</sup> / <sub>32</sub>	25 <sup>1</sup> / <sub>16</sub>	25 <sup>1</sup> / <sub>16</sub>
B	20 <sup>13</sup> / <sub>16</sub>	25 <sup>15</sup> / <sub>16</sub>	32 <sup>1</sup> / <sub>2</sub>	41 <sup>7</sup> / <sub>8</sub>	70 <sup>3</sup> / <sub>4</sub>	88 <sup>3</sup> / <sub>4</sub>	111 <sup>1</sup> / <sub>8</sub>
C	26	23	31 <sup>1</sup> / <sub>4</sub>	40 <sup>3</sup> / <sub>4</sub>	23 <sup>3</sup> / <sub>8</sub>	42 <sup>1</sup> / <sub>4</sub>	42 <sup>1</sup> / <sub>4</sub>

**NOTE:** All dimensions in inches subject to manufacturing tolerances.

## MDT Control System

C000635

### Application:

Modulating Discharge  
Temperature Control

### Includes:

Discharge air sensor <sup>⑤</sup> mounted in unit discharge with remote mounted 4 x 4 box cover <sup>⑥</sup> including manual potentiometer to enable unit and adjust temperature setpoint, Fan On Light, Burner On Light and Cool On Light. Additional potentiometer is provided if optional return air damper section for manual or mixed air control is ordered.

### COMPONENT I.D.

- 1. Unit DDC Controller
- 2. Signal Conditioner

- 3. Modulating Gas Valve
- 4. Inlet Air Sensor

- 5. Discharge Air Sensor
- 6. Remote Control Station

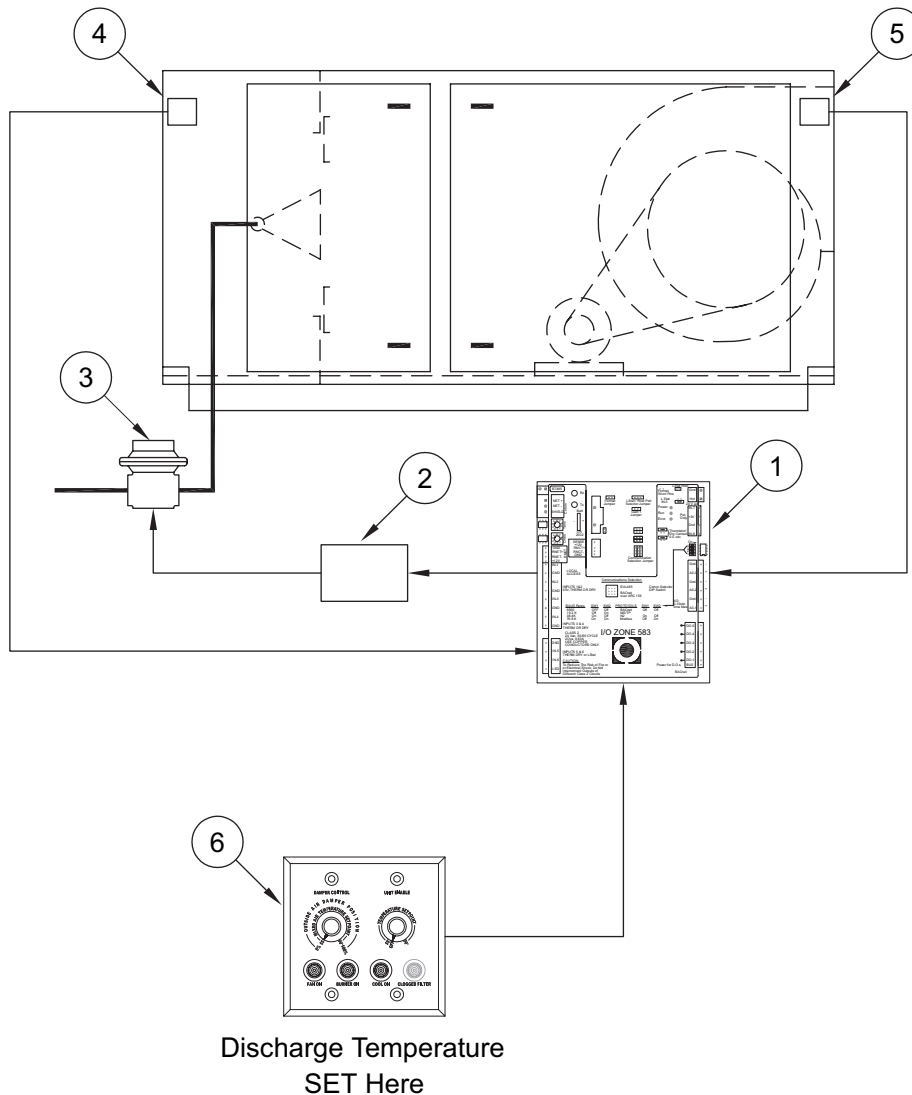

# Control Systems

## MRT Control System

C000634

### Application:

Modulating Room  
Temperature Control

### Includes:

Discharge air sensor <sup>⑤</sup> mounted in unit discharge with remote mounted 4 x 4 box cover <sup>⑦</sup> including manual potentiometer to enable unit and adjust temperature setpoint, Fan On Light, Burner On Light and Cool On Light. Also includes RS-std room sensor <sup>⑥</sup> (does not allow remote room setpoint adjustment. Additional potentiometer is provided if optional return air damper section for manual or mixed air control is ordered.

### COMPONENT I.D.

- 1. Unit DDC Controller
- 2. Signal Conditioner

- 3. Modulating Gas Valve
- 4. Inlet Air Sensor

- 5. Discharge Air Sensor
- 6. Room Thermostat
- 7. Remote Control Station

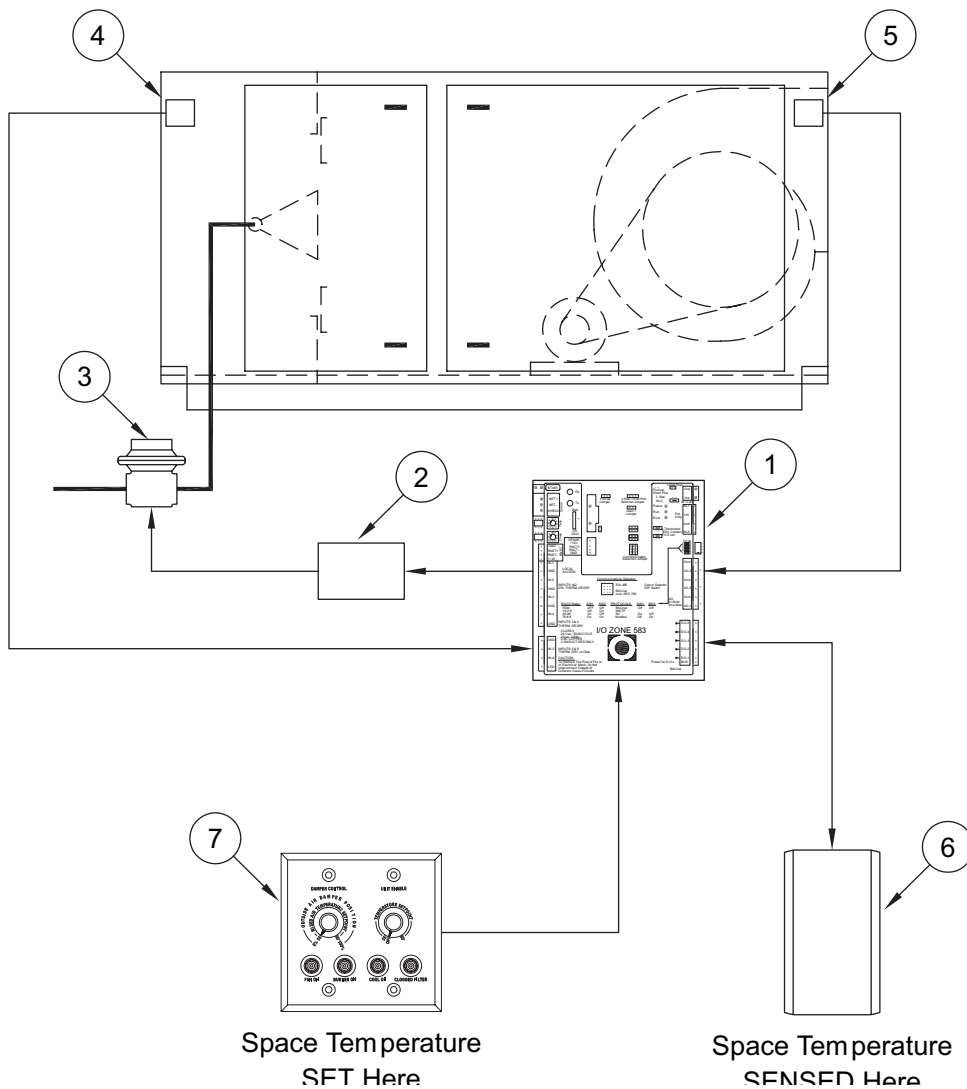

## MRT Pro Control System

C000633

### Application:

Modulating Room Temperature Control with RS-Pro room sensor allowing after hours unit enable, room setpoint adjustment, and digital temperature readout.

### Includes:

Discharge air sensor<sup>⑤</sup> mounted in unit discharge with remote mounted RS-Pro room sensor<sup>⑥</sup> with push buttons for room setpoint adjustment and digital temperature readout. On units with optional return air damper section a remote mounted 4 x 4 box cover is provided with potentiometer for manual or mixed air control.

### COMPONENT I.D.

- 1. Unit DDC Controller
- 2. Signal Conditioner

- 3. Modulating Gas Valve
- 4. Inlet Air Sensor

- 5. Discharge Air Sensor
- 6. Room Thermostat

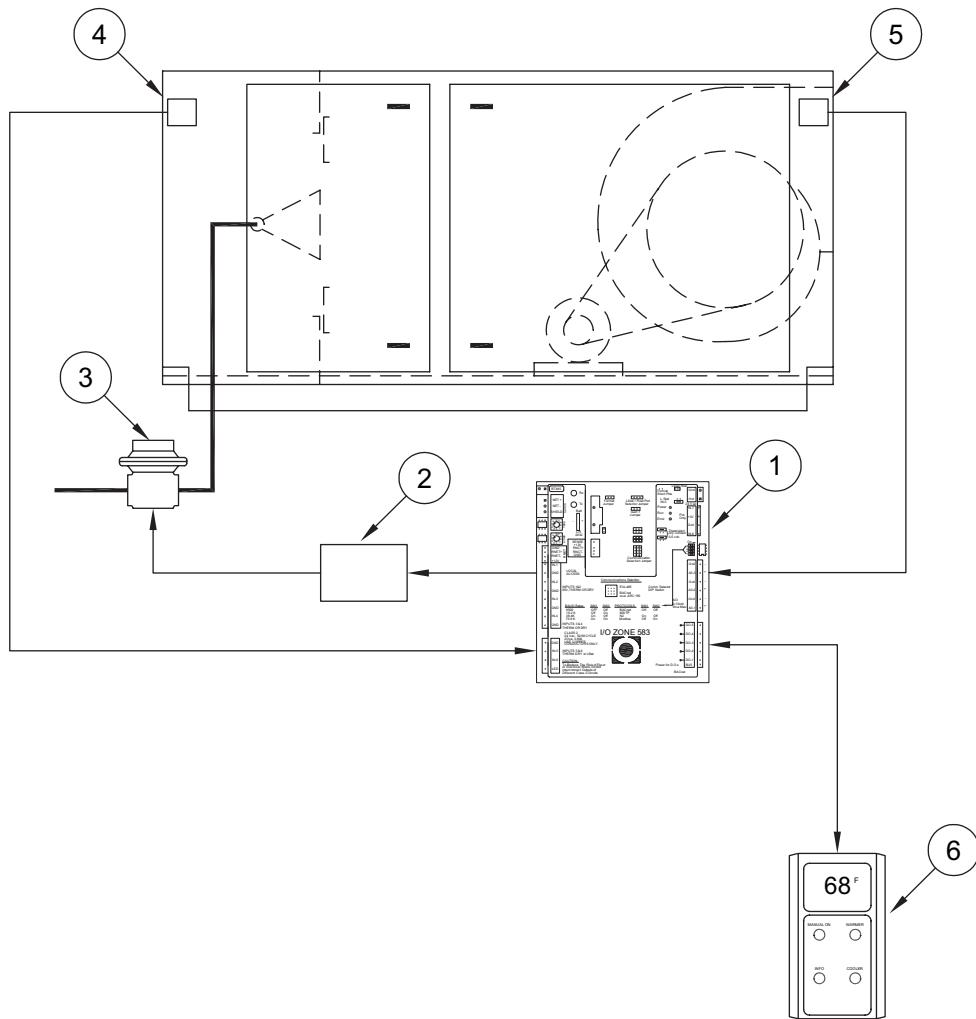

Space Temperature  
SET And SENSED Here

# Control Systems

## MRT Expert Control System

C000632

### Application:

Modulating Room Temperature Control with BACview controller allowing after hours unit enable, room setpoint adjustment, operating feedback, monitoring of alarm status and digital temperature readout with RS-std room sensor.

### Includes:

Discharge air sensor <sup>⑤</sup> mounted in unit discharge with remote mounted BACview controller <sup>⑦</sup> to set space temperature, operating schedules, and optional damper control setpoints. Service information, operating feedback and alarm status can also be monitored. Also includes a RS-std room sensor <sup>⑥</sup>.

### COMPONENT I.D.

- 1. Unit DDC Controller
- 2. Signal Conditioner

- 3. Modulating Gas Valve
- 4. Inlet Air Sensor

- 5. Discharge Air Sensor
- 6. Room Thermostat

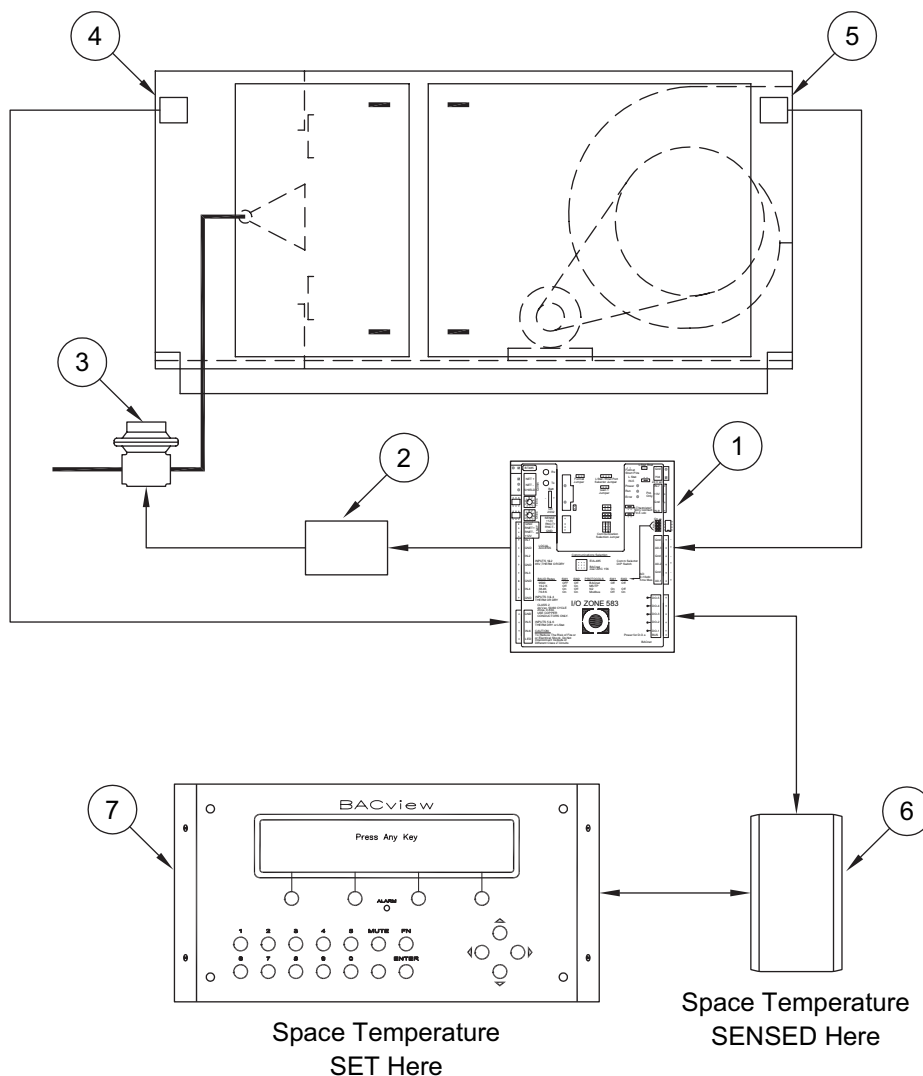

# Wiring Diagram

## Typical Wiring Diagram - Page 1

C000630

### COMPONENT IDENTIFICATION

- CB-09 CONTROL CIRCUIT TRANSFORMER BREAKER
- FL-02 HIGH TEMPERATURE LIMIT SWITCH
- FL-05 SUPPLY AIR FIRESTAT (OPTIONAL)
- FL-06 RETURN AIR FIRESTAT (OPTIONAL)
- GA-03 COMBINATION CO & NO2 DETECTOR (OPTIONAL)
- KP-01 KEYPAD /DISPLAY MODULE (OPTIONAL)
- LT-05 BURNER ON LIGHT (REMOTE)
- LT-15 FAN ON LIGHT (REMOTE)
- LT-31 COOLING ON LIGHT (REMOTE)
- LT-59 CLOGGED FILTER LIGHT (REMOTE)
- MP-05 DAMPER CONTROL POTENTIOMETER (OPTIONAL)
- MP-15 UNIT ENABLE POTENTIOMETER
- MT-01 MAIN SUPPLY FAN MOTOR
- MT-12 DISCHARGE DAMPER MOTOR (OPTIONAL)
- MT-13 INLET DAMPER MOTOR (OPTIONAL)
- MT-14 MIXING BOX DAMPER MOTOR (OPTIONAL)
- OL-01 MAIN FAN MOTOR OVERLOAD
- PS-04 LOW GAS PRESSURE SWITCH (OPTIONAL)
- PS-07 HIGH GAS PRESSURE SWITCH (OPTIONAL)
- PS-10 HIGH VELOCITY SWITCH
- PS-11 LOW VELOCITY SWITCH
- PS-12 CLOGGED FILTER SWITCH (OPTIONAL)
- PT-13 BUILDING PRESSURE TRANSDUCER (OPTIONAL)
- PT-15 FLOW STATION PRESSURE TRANSDUCER (OPTIONAL)
- RE-02 FLAME SAFEGUARD RELAY
- RE-09 FLAME FAILURE RELAY
- RE-12 CLOGGED FILTER RELAY (OPTIONAL)
- RE-14 HOLDING RELAY (OPTIONAL)
- RE-26 ELECTRONIC RELAY
- RE-27 BURNER STATUS RELAY
- RE-28 BURNER ENABLE RELAY
- RE-34 COOLING ENABLE RELAY
- RE-35 COOLING INTERLOCK RELAY
- RE-56 SAFETY CIRCUIT STATUS RELAY
- RE-57 UNIT ENABLE RELAY
- RE-65 FAN STATUS RELAY
- RE-75 FLAME SUPERVISION SWITCHING RELAY
- RE-78 INTERLOCKING RELAY (OPTIONAL)
- RE-80 LOW ALERT RELAY (OPTIONAL)
- RE-81 HIGH ALERT RELAY (OPTIONAL)
- RE-90 ALARM STATUS RELAY
- RS-01 RESISTOR 1K OHM
- RS-02 RESISTOR 2K OHM
- RS-03 RESISTOR 4.02K OHM
- RS-04 RESISTOR 8.06K OHM
- RS-11 RESISTOR 10 OHM
- ST-01 MAIN SUPPLY FAN MOTOR STARTER
- SW-01 MAIN DISCONNECT SWITCH (OPTIONAL)
- SW-09 AUXILIARY UNIT ENABLE (BY OTHERS)
- SW-18 DAMPER MOTOR END SWITCH (OPTIONAL)
- SW-72 100 PERCENT OUTSIDE AIR SWITCH (BY OTHERS)
- SW-77 PROOF OF VALVE CLOSURE SWITCH (OPTIONAL)
- TR-01 CONTROL CIRCUIT TRANSFORMER
- TR-02 IGNITION TRANSFORMER
- TR-04 MODULATING VALVE TRANSFORMER
- TR-05 LOW VOLTAGE TRANSFORMER
- TR-06 DAMPER MOTOR TRANSFORMER (OPTIONAL)
- TS-01 OUTSIDE AIR TEMPERATURE SENSOR
- TS-02 SPACE TEMPERATURE SENSOR (OPTIONAL)
- TS-03 DISCHARGE AIR TEMPERATURE SENSOR
- UC-01 UNIT CONTROL MODULE
- VG-01 PILOT GAS VALVE
- VG-02 MAIN GAS VALVE
- VG-03 AUXILIARY GAS VALVE
- VG-04 NORMALLY OPEN VENT VALVE (OPTIONAL)
- VG-07 MODULATING GAS VALVE

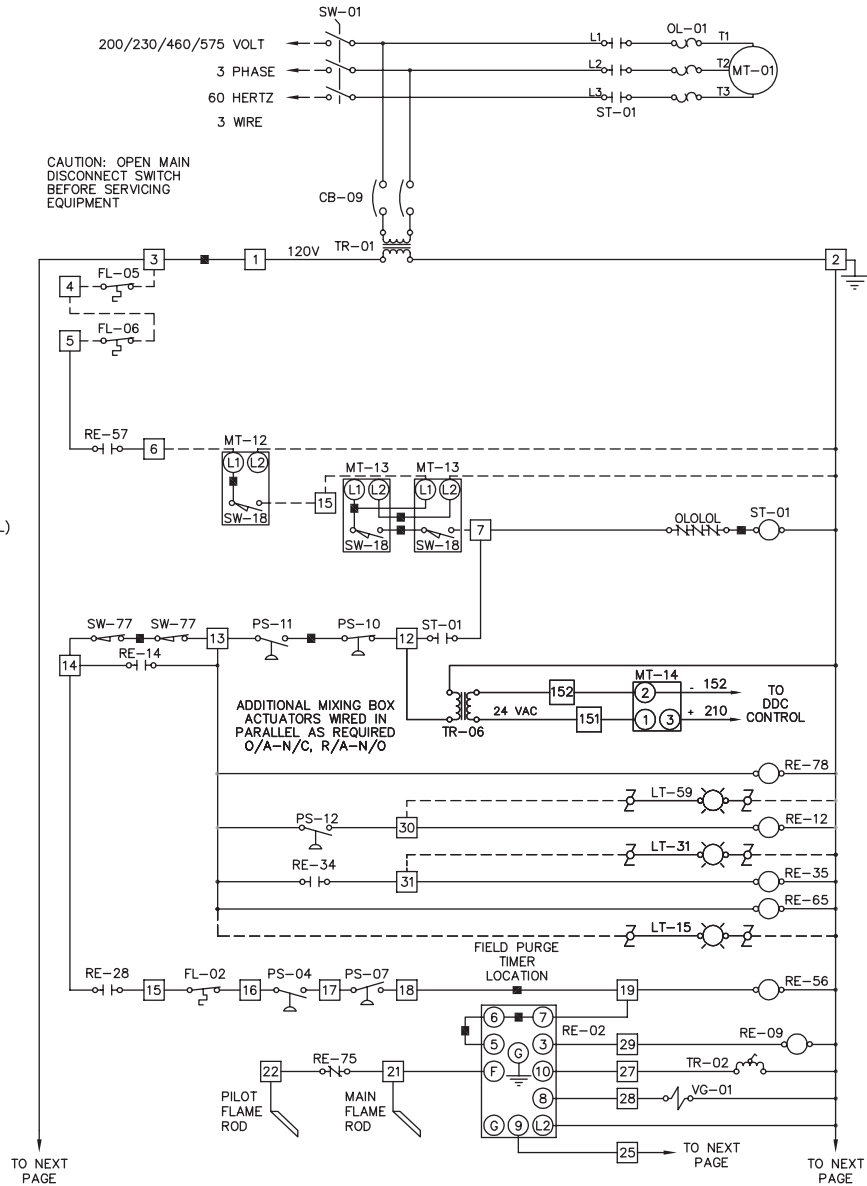

# Wiring Diagram

## Typical Wiring Diagram - Page 2

C000630

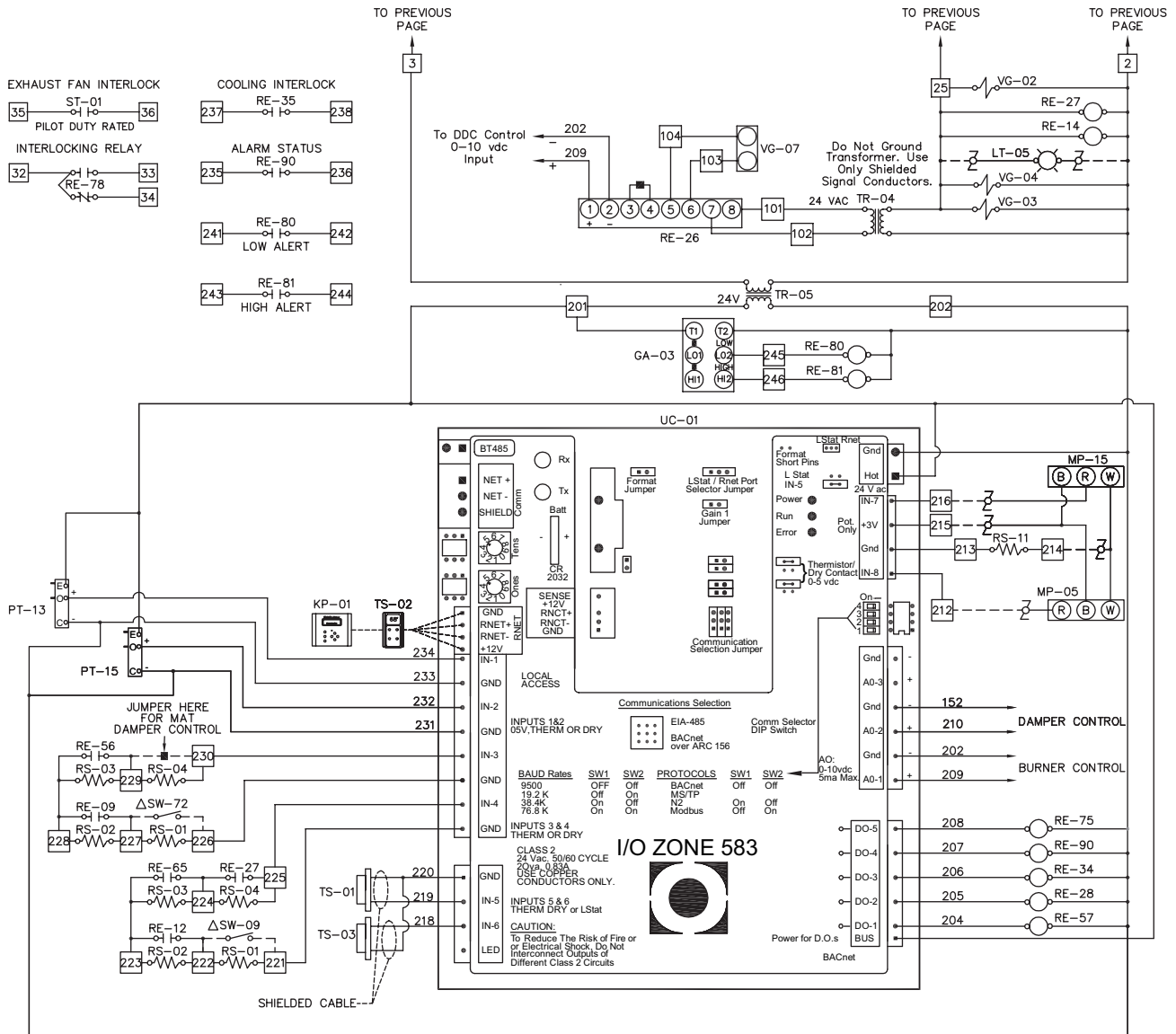

# Electrical Data and Sequence of Operation

## Amp Draw Table

ITEM	SOURCE	AMPS	MOTOR HORSEPOWER						
			1	1½	2	3	5	7½	10
A	Blower Motor	AMPS for 208V 3 Ph.	4.6	6.6	7.5	10.6	16.7	24.2	30.8
		AMPS for 230V 3 Ph.	4.2	6.0	6.8	9.6	15.2	22.0	28.0
		AMPS for 460V 3 Ph.	2.1	3.0	3.4	4.8	7.6	11.0	14.0
		AMPS for 575V 3 Ph.	1.7	2.4	2.7	3.9	6.1	9.0	11.0
ITEM	SOURCE	AMPS	MOTOR HORSEPOWER						
			15	20	25	30	40	50	60
A	Blower Motor	AMPS for 208V 3 Ph.	46.2	59.4	74.8	88.0	114.0	143.0	169.0
		AMPS for 230V 3 Ph.	42.0	54.0	68.0	80.0	104.0	130.0	154.0
		AMPS for 460V 3 Ph.	21.0	27.0	34.0	40.0	52.0	65.0	77.0
		AMPS for 575V 3 Ph.	17.0	22.0	27.0	32.0	41.0	52.0	62.0
ITEM	SOURCE	AMPS	CONTROL CIRCUIT AMPS						
			Heating Only Unit						
B	Control Transformer	AMPS for 208V 3 Ph.	2.4						
		AMPS for 230V 3 Ph.	2.2						
		AMPS for 460V 3 Ph.	1.1						
		AMPS for 575V 3 Ph.	0.9						

Steps to size optional disconnect switch:

1. Find the blower motor HP required from tables on pages 4 and 5.
2. Find amp draw for required motor HP from chart in Item A above.
3. Find amps for control circuit from chart in Item B above.
4. Add amps from step 2 and step 3, multiply by 1.25.

NOTES:

1. Above motor amps are based on 2002 edition of NEC.
2. Control circuit amps are based on standard controls.

## Sequence of Operation – Return Air Units

P000621

### OPERATION WITH RETURN AIR UPSTREAM OF BURNER

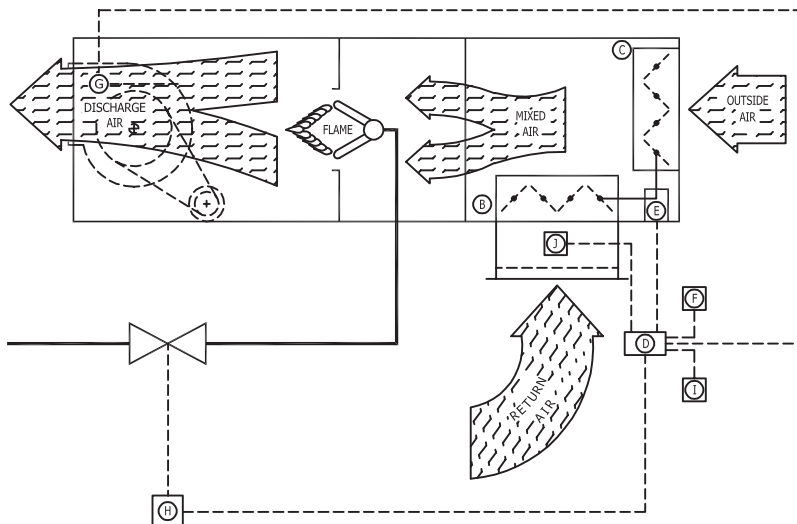

Signal from remote control I to AdaptAire Controller D, sets operational parameters for dampers B and C, and burner. Damper operation can be manual, building pressure or mixed air temperature.

Return air dampers B, and outside air dampers C, are interlocked to move together. As one opens, the other closes. As the return air dampers open, allowing more return air to enter the unit, the outside air dampers move toward the closed position, decreasing the amount of outside air. Pressure sensor and flow station J, senses change in return airflow and signals AdaptAire Controller D.

Modulating gas valve H, regulates gas supply in response to signal from AdaptAire Controller D. AdaptAire Controller D, varies signal based on input from room temperature sensor F, discharge temperature sensor G, and airflow sensor J. Gas valve H can provide approximately 4% to 100% of rated burner capacity.

# Typical Gas Piping Layout

## Schematic Component Diagrams

C000148

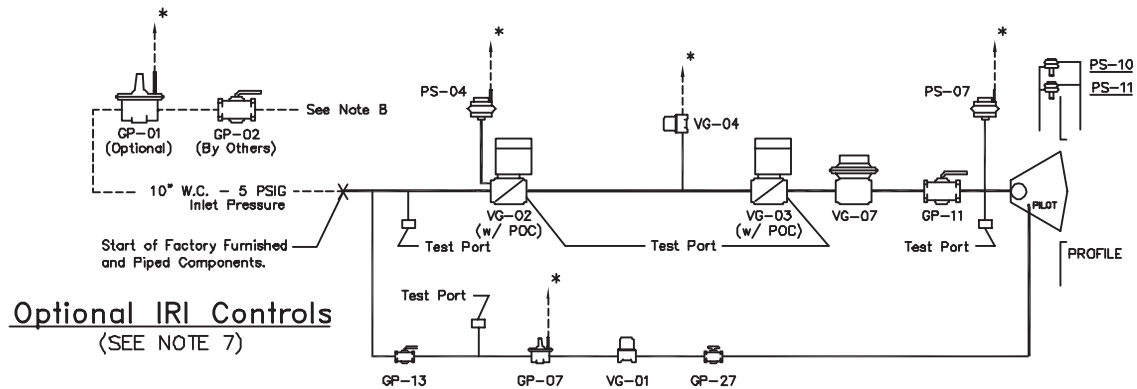
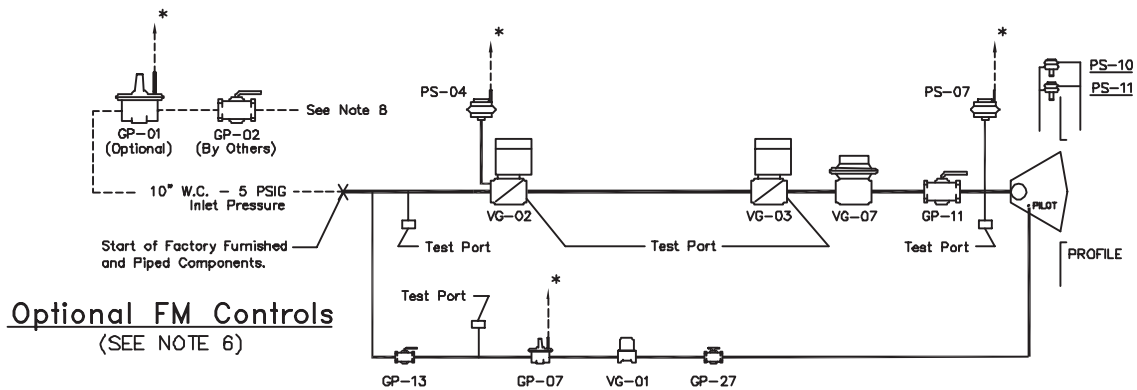
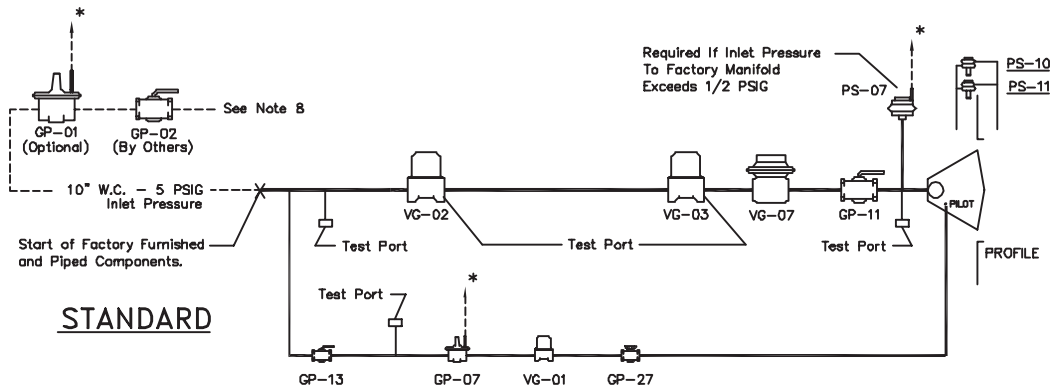

### COMPONENT IDENTIFICATION

- GP-01 HIGH GAS PRESSURE REGULATOR
- GP-02 MAIN GAS SHUT-OFF VALVE
- GP-09 PILOT GAS PRESSURE REGULATOR
- GP-11 MAIN TEST FIRING SHUT-OFF VALVE
- GP-13 PILOT GAS SHUT-OFF VALVE
- GP-27 ORIFICED NEEDLE VALVE
- VG-01 PILOT GAS VALVE
- VG-02 MAIN GAS VALVE
- VG-03 AUXILIARY GAS VALVE
- VG-04 NORMALLY OPEN VENT VALVE
- VG-07 MODULATING VALVE
- PS-04 LOW GAS PRESSURE SWITCH
- PS-07 HIGH GAS PRESSURE SWITCH
- PS-10 HIGH VELOCITY PRESSURE SWITCH
- PS-11 LOW VELOCITY PRESSURE SWITCH

### NOTES:

1. Vent limiting devices provided wherever possible, when venting is required\* the venting to outside is by others on indoor units.
2. Units with 900 MBH and less use a pressure regulator (not shown) for high fire setting.
3. For inlet pressures under 10" W.C. - Please consult factory.
4. 3,300 MBH and above will require a minimum inlet pressure of 1 PSIG. For inlet pressures under 1 PSIG - Please consult factory.
5. Units that are listed to the Z83.4 standard (100% make-up air) carry both ETL and CETL approvals.
- 6. Standard manifold meets FM requirements for inputs under 2,500 MBH for ETL listed units.**
- 7. Standard manifold meets IRI requirements for ETL listed units.**
8. High gas pressure regulator required if inlet pressure exceeds 1/2 PSIG for inputs up to and including 900 MBH or inlet pressures over 5 PSIG for inputs greater than 900 MBH.

# Cabinet Arrangements and Weights

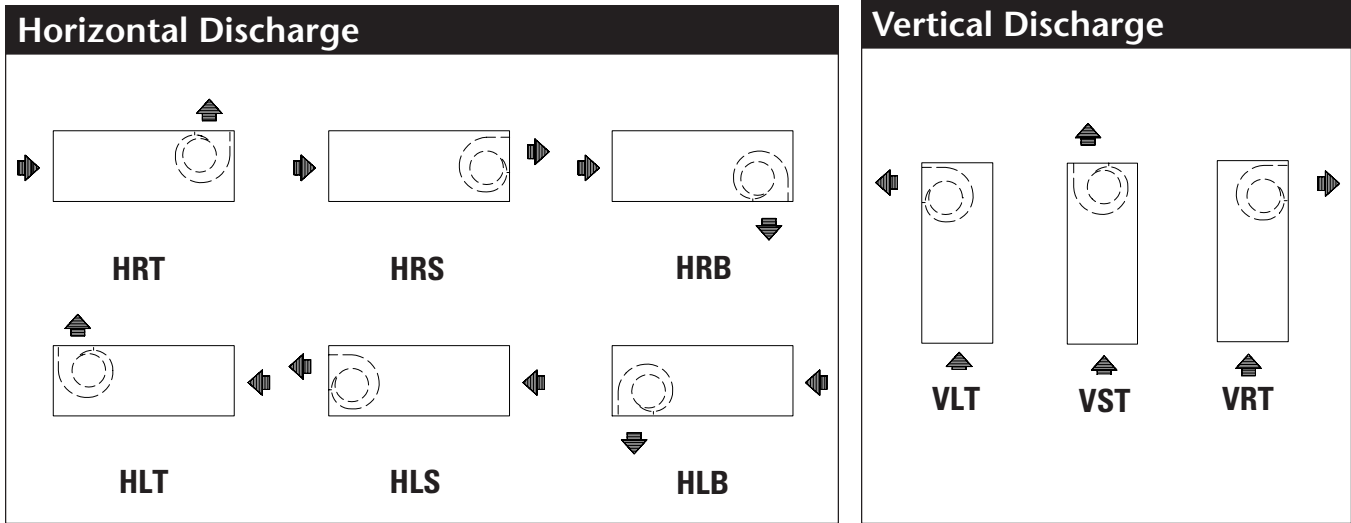

For all arrangements shown, controls are on near side.

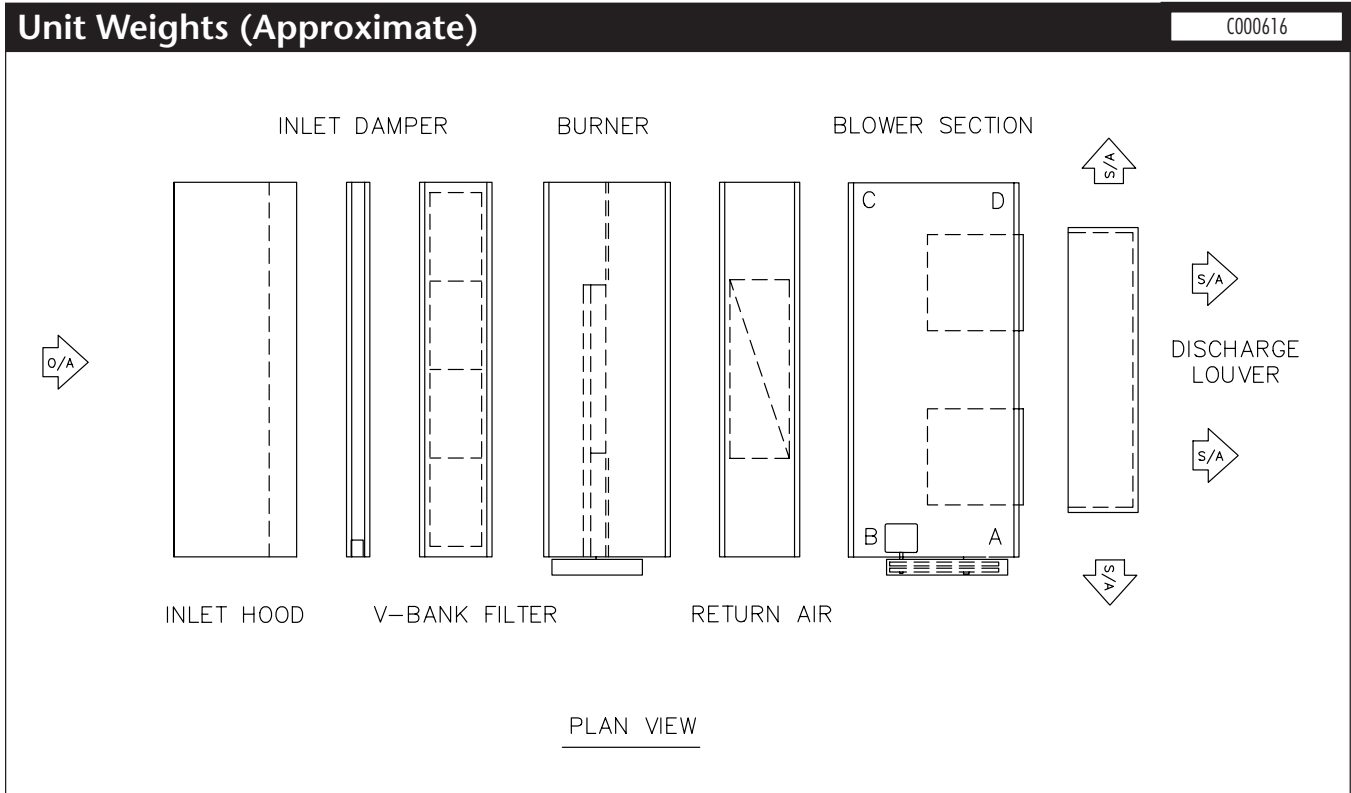

Model	Blower Section				Inlet Hood	Vertical Stand	Inlet Damper	V-Bank Filter	Burner	Return Air	Airflow Station	Discharge Louver
	A	B	C	D								
109-112	67	149	67	67	140	134	55	165	260	104	43	70
115-118	94	253	94	94	150	149	70	185	375	116	73	80
120-122	159	439	159	159	183	259	120	275	550	151	88	110
125-130	224	590	224	224	216	356	155	310	700	208	101	125
215-218	158	438	158	158	224	242	125	275	510	141	123	150
220-222	268	697	268	268	290	387	233	410	725	226	161	215
225-230	388	953	388	388	350	517	340	500	1010	302	191	230

APPROXIMATE WEIGHT (LBS.)

# Guide Specification – Base Unit



Base Bid Applied Air model DFM\_\_\_\_ make-up air unit(s) designed for indoor application. The unit discharge shall be designed for easy adaptation to external duct work or optional accessories. The unit(s) shall be capable of delivering \_\_\_ cfm at \_\_\_ ESP using a \_\_\_ horsepower (ODP) (TEFC) motor operating on (208/3/60) (230/3/60) (460/3/60).

## Burner Section

The line burner shall be capable of delivering \_\_\_BTUH firing on (natural gas) (propane) at an inlet pressure of \_\_\_ (inches water column) (PSIG). The standard ETL listed unit will meet ANSI, FM, and IRI requirements. Both burner and blower shall be compensated for an altitude of \_\_\_ feet above sea level. Manifold to be located outside of air stream. An observation port shall be located to provide view of pilot and main flame.

Unit(s) shall be supplied with a wide range burner with a modulating turndown ratio of 25:1. Adjustable profile plates shall be provided and sized to maintain the require velocity across the line burner. The operation of the burner shall be programmed through the flame safeguard with timed prepurge and flame-sensed by means of a (flame rod)(ultra violet scanner).

The burner assembly and gas manifold shall be completely prepiped and factory tested prior to shipment.

The unit shall be controlled by the AdaptAire DDC control module with full BACnet compatibility. Unit shall have the AdaptAire (MDT - Modulating Discharge Temperature Control System)(MRT – Modulating Room Temperature Control System)(MRT-Pro Modulating Room Pro Temperature Control System)( MRT-Expert Modulating Room Expert Temperature Control System). The AdaptAire DDC control system shall include but not be limited to the following controls required for standard operation:

- Electronic time clock with normal, holiday, and override schedules. (Optional accessory on MDT or MRT Control Systems).
- Timed freeze protection to prevent heater from discharging unheated air into the building.
- Inlet On-Off ductstat which will turn burner off when inlet temperature equals desired discharge air temperature as fuel savings mode.
- On-Off night setback thermostat for lower operating temperatures in unoccupied mode as fuel savings mode. (Optional accessory on MDT or MRT Control Systems).

## UNIT CASING

Unit casing and accessories shall be fabricated from heavy-gauge bright spangled galvanized steel suitably reinforced to insure rigidity. All casings shall be air tight. Complete access shall be provided to all components. This includes the blower, burner, and electrical components.

## BLOWER SECTION

Each unit shall be supplied with centrifugal forward curve, DWDI fan(s) rated in accordance with AMCA standards. The fan or fans shall be mounted on a solid shaft for single blowers and a hollow shaft for double blowers. Shaft designed for a maximum operating speed not to exceed 75% of its first critical speed. Bearings are to be external heavy-duty industrial prelubricated type. Blowers to be driven by a V-belt package sized with a capacity of 25% greater than the motor horsepower. Multiple belt applications will be matched sets. Drives are to be (fixed) (adjustable). Maximum outlet velocity \_\_\_\_\_ FPM. Motor to be externally mounted on adjustable slide base. Belt guard shall be provided for protection.

## CONTROL ENCLOSURE

The units(s) shall be supplied with a control compartment and all controls mounted within this compartment are to be wired to a numbered terminal strip. All wiring is to be color coded and in accordance with the NEC. A circuit diagram of the approved electrical drawing is to be laminated to the inside of the control cabinet door. All electrical components shall bear a recognized label.

## STANDARD CONTROLS

1. Main fan starters and overloads
2. Control circuit fuses
3. High temperature limit switch
4. Flame safeguard with alarm contacts
5. Flame rod sensor
6. Ignition transformer
7. Automatic pilot valve
8. Main gas automatic safety shutoff valve
9. MDT Control System
10. Air proving differential switch
11. Control transformer
12. Remote control panel

## OPTIONAL ACCESSORIES

1. Motorized inlet damper
2. V-bank filter box with filters
3. Insulation
4. Vibration hangers or mounting feet
5. Clogged filter switch
6. Disconnect switch
7. High gas pressure regulator (required for inlet pressures over 1/2 PSIG)
8. UV flame detection (mini or purple peeper)
9. Painted galvanized casing
10. U. L. labeled control panel
11. Vertical arrangement with support stand and inlet birdscreen
12. Mixed air section with or without return air flow station
13. Firestat
14. 115 Volt service receptacle
15. BACviewController

# Guide Specification – Mixing Dampers With Return Air Flow Station



Applied Air®

Unit(s) shall have outside air and return air dampers with modulating actuator controlled by AdaptAire DDC control system. The AdaptAire DDC control system shall have capability to digitally control the outside air quantity from a nominal minimum of 20% to 100% with integrated gas valve control at all room concentrations of CO<sub>2</sub>.

The return air inlet shall include a self-calibrating flow measuring station with a grid of velocity pressure probes with spacing no greater than 12" over the entire face of the return air opening and sampled every two seconds. Samples will be added to a twenty-five point rolling average and then on to a second rolling average to provide smooth, accurate data that is delivered to the AdaptAire DDC control system every two seconds. The DDC control system shall be capable of electronically displaying the return air/outside air ratio within 5% accuracy at all damper positions.

The AdaptAire DDC control system shall be capable of controlling mixing dampers in: (Choose One)

**Manual Mode:** The "Manual" mode allows manual positioning of the outside air (O.A.) damper and return air (R.A.) damper by changing the damper position setpoint.

**Mixed Air Temperature Mode:** The "Mixed Air Temperature" mode shall provide automatic control of the mixed air temperature by modulating the outside air (O.A.) damper and return air (R.A.) damper to maintain the mixed air temperature setpoint. As the mixed air temperature increases above the setpoint more outside air will be introduced.

**Building Pressure Mode:** The "Building Pressure" mode shall provide automatic building pressure control by modulating the outside air (O.A.) damper and return air (R.A.) damper to maintain the indoor building pressure setpoint. As the building pressure decreases below the setpoint more outside air will be introduced.

# Guide Specification – BACview Controller



The display functions of the remote keyboard display for the AdaptAire DDC control system shall have a minimum of two lines, sixteen character display which shall include but not limited to the following:

- Return air temperature
- Outside air temperature
- Discharge air temperature
- Mixed air temperature
- Maximum allowable temperature rise
- Actual temperature rise
- Current percent of outside air
- Current building pressure (optional)
- Current damper input voltage (optional)
- Current burner input voltage
- Fan operating hours since last reset
- Fan start cycle count since last reset
- Burner operating hours since last reset
- Burner start cycle count since last reset
- Cooling interlock operating hours since last reset
- Cooling interlock cycle count since last reset
- Critical alarm conditions:
  - o Airflow switch failure
  - o Unit on, fan off
  - o Unit off, fan on
  - o Low discharge temperature
  - o Safety circuit open
  - o Burner jumped

The control settings available on the remote keyboard display for the AdaptAire DDC control system shall include but not be limited to the following:

- Heating setpoint
- Cooling setpoint
- Economizer options
- Setback setpoint
- Freeze protection setpoint
- Maximum discharge air temperature setpoint
- Minimum discharge air temperature setpoint
- Minimum ventilation option and setpoint
- Time of day schedule selection and setpoints (Not available on MDT or MRT Control Systems)
  - o Normal 5/7 schedule
  - o Holiday schedule
  - o Manual override



Applied Air®

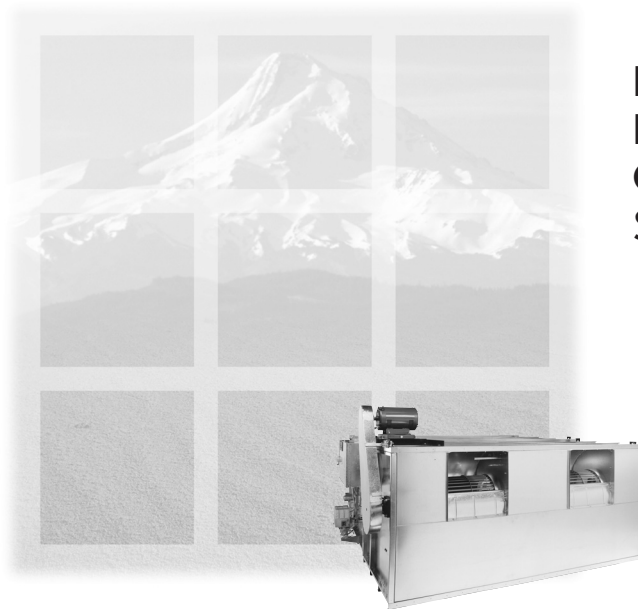

## Efficient Direct Fired Gas Heating System

### Choose Applied Air Direct Fired Gas Heating

- Heat large or small spaces efficiently with 100% combustion efficiency
- Constantly replace contaminated indoor air with fresh, heated outside air
- Low operating and maintenance costs
- Fresh air ventilation anytime — just turn off the gas heating system
- Simple, inexpensive installation
- Applied Air, a leader in research, engineering, and customer service since 1975
- Fans tested to AMCA standards to insure rated airflow

Applied Air

[www.appliedair.com](http://www.appliedair.com)

4830 Transport Drive Dallas TX 75247

Telephone 214.638.6010

Fax 214.905.0806

