



# Applied Air

## INSTALLATION, OPERATION AND MAINTENANCE MANUAL FOR DFL MODEL

### DIRECT GAS-FIRED HEATERS WITH DDC CONTROLS

**ATTENTION: READ THIS MANUAL AND ALL LABELS ATTACHED TO THE UNIT CAREFULLY BEFORE ATTEMPTING TO INSTALL, OPERATE OR SERVICE THESE UNITS! CHECK UNIT DATA PLATE FOR TYPE OF GAS AND ELECTRICAL SPECIFICATIONS AND MAKE CERTAIN THAT THESE AGREE WITH THOSE AT POINT OF INSTALLATION. RECORD THE UNIT MODEL AND SERIAL No.(s) IN THE SPACE PROVIDED. RETAIN FOR FUTURE REFERENCE.**

#### FOR YOUR SAFETY

The use and storage of gasoline or other flammable vapors and liquids in open containers in the vicinity of this appliance is hazardous.

#### POUR VOTRE SÉCURITÉ

L'utilisation et l'entreposage d'essence ou d'autres liquides ou produits émettant des vapeurs inflammables dans des récipients ouverts à proximité de cet appareil est dangereux.



#### FOR YOUR SAFETY

If you smell gas:

1. Open Windows
2. Don't touch electrical switches.
3. Extinguish any open flame.
4. Immediately call your gas supplier.



#### POUR VOTRE SÉCURITÉ

Si vous sentez une odeur de gaz :

1. Ouvrez les fenêtres.
2. Ne pas actionner d'interrupteur.
3. Éteindre toute flamme ouverte.
4. Appelez immédiatement votre fournisseur de gaz.

**WARNING: Improper installation, adjustment, alteration, service or maintenance can cause property damage, injury or death. Read the installation, operating and maintenance instructions thoroughly before installing or servicing this equipment.**

**AVERTISSEMENT : Une installation déficiente, de même qu'un mauvais réglage, modification, entretien ou maintenance peuvent occasionner des dommages matériels, corporels voire causer la mort. Lire attentivement les instructions d'installation, d'utilisation et d'entretien avant d'installer ou d'intervenir sur cet appareil.**

#### WARNING

Install, operate and maintain unit in accordance with manufacturer's instructions to avoid exposure to fuel substances or substances from incomplete combustion which can cause death or serious illness. The state of California has determined that these substances may cause cancer, birth defects, or other reproductive harm.

#### INSTALLER'S RESPONSIBILITY

**Installer Please Note:** This equipment has been test fired and inspected. It has been shipped free from defects from our factory. However, during shipment and installation, problems such as loose wires, leaks or loose fasteners may occur. **It is the installer's responsibility to inspect and correct any problems that may be found.**



Applied Air

4830 Transport Drive, Dallas, TX 75247 Phone: 214-638-6010  
www.appliedair.com

## SECTION I - FOREWARD

As is the case with any fine piece of equipment, care must be taken to provide the proper attention to the operation and maintenance details of this machine.

This manual of instructions along with the Digital Control System user manual has been prepared in order for you to become well-acquainted with those details, and in doing so, you will be able to give your Direct Gas-Fired System the care and attention which any piece of equipment needs and deserves.

**It is the customer and installation personnel responsibility to determine if the unit is equipped with all of the safety devices required for the particular application. Safety considerations include the accessibility of the unit to non-service personnel, the provision of electrical lockout switches, maintenance procedures, and automatic control sequences. Clearly mark all emergency shutoff devices.**

### Table of Contents

Section I: Foreword, Table of Contents, and Important Notice .....	2
Section II: General Information .....	3
Section III: Installation.....	4
Section IV: Pre-Start Up .....	8
Section V: Unit Start Up.....	9
Section VI: Unit Shut Down.....	11
Section VII: Troubleshooting Guide.....	12
Section VIII: Maintenance Schedule and Lubrication Requirements.....	24
Section IX: Mestek Burner.....	29
Section X: Manifold and Valve Adjustments.....	30
Section XI: Thermistor Curves.....	31
Section XII: Replacement Parts.....	32
Section XIII: Recirculating Units .....	32

### \*IMPORTANT NOTICE\*

Applied Air assumes no responsibility for loss or damage in transit; therefore, you should protect yourself by following these instructions:

#### Bill Of Lading

Save your bill of lading. It is a contract, and you will need it, provided you have to file a loss or damage claim. Remember, claims are outlawed after nine months.

#### Loss In Transit

Before you sign for this shipment, check against the bill of lading, also the transportation company's delivery ticket. Make sure that you get the exact total of articles listed. Should the delivery ticket show more or less items than are offered, then the carrier's agent must mark the difference on your freight bill before you sign.

#### Visible Damage In Transit

If anything is damaged, accept the shipment only if the carrier's agent places a notation on your freight bill explaining the nature and extent of damage. Upon inspection of article, make claim to the delivering carrier.

#### Concealed Damage In Transit

Sometimes transit damage is not noticed until the goods are unpacked. In such cases, notification to the carrier must be made within fifteen (15) days of receipt of shipment. In such cases, save the packages and packing material, then notify the transportation company at once, and request an inspection. When the inspector calls, have him make out and leave a "concealed" bad order report. He is obliged to give one to you. Insist on it.

#### Disposition Of Damaged Atticles

Never return damaged articles to us. They are the property of the transportation company when the claim is filed. They will give you disposition instructions.

#### Packing

We comply with the packing requirements of the transportation companies, and your bill of lading proved that everything was in good condition when shipped. That bill of lading contract requires them to deliver in perfect condition.

## SECTION II - GENERAL INFORMATION

### A. Purpose

The purpose of this manual is to present a guide for proper installation, maintenance, and operation of the Direct Gas-Fired System, and supplement, **but not to replace**, the services of qualified field service personnel to supervise the initial start-up and adjustment of the unit. Persons without previous experience with large commercial and industrial heating equipment should not attempt the initial adjustment and checkout procedure which is essential before such installations may be considered ready for operation. This manual should be made readily available to all operating personnel as an aid in troubleshooting and proper maintenance.

### B. Shipping

Base Direct Gas-Fired units are shipped completely assembled where shipping limitations allow. Optional inlet hoods, filter and/or damper sections, or other large accessories are assembled and shipped mounted and wired whenever possible within limitations of shipping and handling. Any optional accessories shipped separately are shipped as assembled sections. Any wired accessories which have been disassembled for separate shipment require no additional conduit or wire for field reassembly. All wire leads will be tagged for ease of reconnection in the field.

**If the unit and/or accessories cannot be installed immediately, they should be stored in a clean dry environment. If this is not possible and the unit must be stored outdoors, it should be protected from the weather with tarpaulins or plastic coverings. Do not assume that simply covering a unit will keep insects, dust and condensation out of the unit and critical components. Rotate the fan(s) monthly.**

Prior to beginning installation of a unit that has been in storage for weeks or months, the unit and its components should be closely inspected.

Shipments are made F.O.B. Dallas, Texas by flat-bed truck. The unit is securely strapped, tied, and blocked to prevent shipping damage. All shipments are checked by an inspector before they are accepted by the carrier. Parts that are shipped unmounted are noted on the bill of lading. These parts, where feasible, are packaged and shipped with the units. Upon receipt of shipment, all units should be checked against the bill of lading to insure all items have been received. All equipment (and any optional accessories) should be checked carefully for physical damage in the presence of the carrier's representative. If parts are missing or damage has occurred, a claim should be filed immediately with the carrier.

All Direct Gas-Fired units are given a complete operations test and control circuit checkout before shipment. Copies of the wiring diagram, piping diagram and bill of material are included with each unit shipped. If correspondence with the factory is necessary, please provide the unit model and serial number.

### C. Optional Factory Service

Periodic service on any piece of mechanical equipment is necessary for efficient operation. A nationwide service support network is available to provide quick and dependable servicing of make-up air, heating, ventilating, or air handling types of equipment. Factory start-up service is also available which includes the presence of a service engineer to supervise the initial start-up and adjustment of the equipment and provide instructions for the owner's maintenance personnel in proper operations and maintenance. Consult factory for quotations on start-up or periodic service.

## SECTION III - INSTALLATION

### FOR CANADIAN INSTALLATIONS ONLY

1. All installations must conform with local building codes, or, in the absence of local codes, with current CAN/CGA-B149-Installation Codes For Gas Burning Appliances and Equipment.
2. All electrical connections must be in accordance with Canadian Electrical Code, Part 1, CSA Standard C22.1.

This equipment must be installed and wired in accordance with regulations of the National Board of Fire Underwriters, National Electrical Code, and local governing bodies. The following recommendations are not intended to supplant any requirements of federal, state, or local codes having jurisdiction. Authorities having jurisdiction should be consulted before installations are made. Local codes may require additional safety controls and/or interlocks.

All installations in airplane hangers must be in accordance with current ANSI/NFPA No. 409. All installations in public garages must be in accordance with current NFPA No. 88A and NFPA No. 88B.

**CAUTION: Do not install heating system in corrosive or flammable atmospheres! Premature failure of, or severe damage to the unit will result!**

**CAUTION: Heating system must not be installed in locations where air for combustion would contain chlorinated, halogenated or acidic vapors. If located in such an environment, premature failure of the unit will occur!**

### A. Handling the Equipment

The Direct Gas-Fired unit has been designed for rigging and handling through the use of special lifting lugs installed on the sides of each unit. As explained previously, the basic unit is designed for shipping in one piece where shipping limitations allow. Some optional accessories may require field mounting.

The Direct Gas-Fired unit has been designed for rigging and handling through the use of special lifting lugs installed at each corner of unit. When unloading and setting the unit, use the lifting lugs provided or move the equipment on rollers. Hooks, jacks, or chains must not be used around the casing, main control panel or exterior mounted controls.

During transit, unloading and setting of the unit, bolts and nuts may have become loosened, particularly in the pillow block ball bearing assemblies in the fan section. It is recommended that all nuts and set screws be tightened. Turn fan shaft by hand to make certain that blower does not rub against blower housing, and that bearing set screws are tight. If units are not set immediately, cover all openings that might be exposed to the weather.

Open the cover on the electrical control box located on the unit. Inspect all wire terminals and wiring terminations to ensure that all connections are tight.

If units are not set immediately, cover all openings that might be exposed to the weather.

Rotate fans monthly.

### RIGGING AND MOUNTING DATA - DIRECT FIRED UNITS

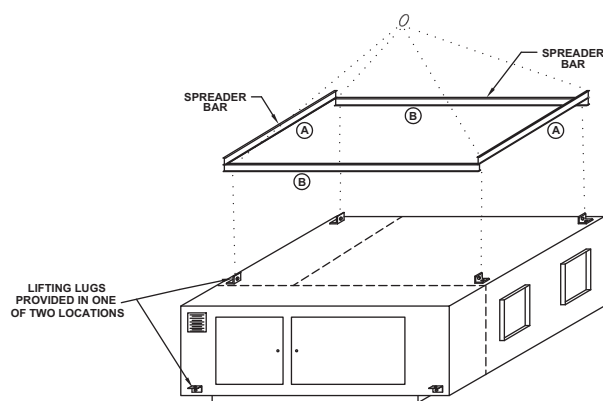

A - USE WHEN LIFTING OVER 3,000 LBS.  
B - USE WHEN LIFTING UNDER 3,000 LBS.

08/16/07 C000539A

**WARNING: To insure that a proper unit lift is made, lift unit approximately 24 inches and verify proper center of gravity lift point. To avoid dropping of unit, reposition lifting point if unit is not level. Failure to properly lift unit could result in death or serious injury or possible equipment or property-only damage.**

**B. Locating the Unit**

Prior to locating the unit, authorities having jurisdiction should be consulted before installations are made. Approval permits should be checked against the unit received.

On Direct Gas-Fired units, which recirculate room air, outside ventilation air must be provided in accordance with the information shown on the heater nameplate. All ventilation air to the heater must be ducted directly from the outside. See Section XIII.

If in doubt regarding the application of this appliance, consult the factory.

Locate the unit exactly level. Special attention should be given to the duct, electrical, and fuel connection points. Install duct work with adequate flexible connections to isolate vibration from the duct work. All duct work should have taped or caulked seams. Duct work should be properly sized so as not to inhibit airflow. This information should be cross-checked with the position of support beams and stand pipes to insure that clearance dimensions coincide with those of the unit. The minimum clearance to combustible material must be maintained as listed in Table 1.

**Table 1**

Minimum clearance to combustible material, also consult local codes and regulations.

<b>Clearances to Combustible Material</b>		
	Vertical Units	Horizontal Units
Front*	39 inches	36 inches
Rear	6 inches	6 inches
Right	6 inches	6 inches
Left	6 inches	6 inches
Top	12 inches	12 inches
Floor	Zero	6 inches

\*Consider control side as front of unit.

\*\*Optimum clearance for shaft removal would be equivalent to cabinet width.

Make a visual inspection to insure no damage has occurred to the unit during installation.

**C. Curb Mounted Units**

Outdoor units can be supplied with an optional roof curb. The curb greatly facilitates installation thereby reducing installation costs. All connections to the unit: duct, piping, electrical power and control wiring can be made through the roof opening. The curb may be shipped prior to unit shipment. All curbs are shipped un-assembled from the factory.

Use extreme caution in handling the curb. Proper handling and positioning will assure a water-tight curb unit installation.

Re-check approval prints prior to installation. Be sure that there are no obstructions to ducting and that proper planning has been exercised in connection of piping and/or electrical services.

The curb assembly may be bolted or welded to either trusses or roof decking; however, connection to roof trusses is recommended. The curb is designed to carry the weight of the unit. Additional support is required for certain applications.

Placement of the curb is critical in squareness and leveling. Shims for leveling must be applied to the curb; application of shims to the unit will tend to destroy the sealing effect after installation. Make sure sealing tape is in place before unit is set. Be careful not to allow gaps where two pieces of sealing tape meet. A bubble level must be used in the leveling process. Measure across diagonals to check for squareness. Allowable tolerance is 1/4" difference between diagonal measurements. Double-check approval prints before setting the unit.

Upon completion of setting the curb, apply roofing material and flashing as required. On outdoor curb mounted installations, flash and seal the roof curb to prevent leakage. The cross section of factory provided curb is formed to accept wood nailing strip and insulation provided by others.

**D. Location of Accessories**

Where applicable, standard or optional accessories will be placed inside the fan section of the unit for shipment, and must be removed and installed by the mechanical or electrical contractor.

Remotely located discharge or inlet dampers must be equipped with an end switch and interlocked to insure maximum design opening before starting and running circuits may be energized.

Field constructed intake accessories should be properly designed to minimize the entry of rain and snow.

Adequate building relief must be provided, so as to not over-pressurize the building, when the heater is operating at its rated capacity. This can be accomplished by taking into account, through standard engineering methods, the structure's designed infiltration rate, by providing properly sized relief openings, by interlocking a powered exhaust system, or by a combination of these methods.



## E. Electrical Connections

**WARNING: Open all disconnect switches and secure in that position before wiring unit. Failure to do so may result in personal injury or death from electrical shock.**

**WARNING: Controls must be protected from water. Do not allow water to drip on the ignition system.**

**NOTE: Before installing any wiring, check the unit rating plate for supply power voltage and minimum ampacity.**

All electrical connections must conform to the current edition of: ANSI/NFPA No. 70 National Electrical Code and applicable state and local codes; in Canada, to the Canadian Electrical Code, Part 1 CSA Standard C22.1 and applicable provincial and local codes.

Since shipment of unit may require disassembly after factory check and test, reconnection of some electrical devices will be required in the field. Connect electrical wires (supplied in factory furnished conduit) to appropriate terminals. All leads are tagged to facilitate field connections. See wiring diagram provided with equipment. Complete all wiring to any optional accessories as shown on unit bill of material and electrical wiring diagram as required before applying voltage to the unit.

Entry location for all field-installed and control wiring is through the control panel.

If optional disconnect is not furnished with heater, the field provided disconnect must be of the proper size and voltage. Refer to unit rating plate for minimum circuit ampacity and voltage. The disconnect must be installed in accordance with Article 430 of the current edition of ANSI/NFPA No. 70 National Electrical Code.

Check the supply voltage before energizing the unit. The maximum voltage variation should not exceed  $\pm 10\%$ . Phase voltage unbalance must not exceed 2%.

**NOTE: Should any original wire supplied with the heater have to be replaced, it must be replaced with wiring material having a temperature rating of at least 105° C.**

**REMARQUE : Dans le cas où un quelconque des câbles livrés avec l'unité devait être remplacé, il doit être remplacé avec des câbles prévus pour résister à une chaleur d'au moins 105° C.**

## F. Field Piping

### Gas Piping

All gas piping must be in accordance with the requirements outlined in the National Fuel Gas Code - ANSI Z223.1. It is required that a ground union be installed adjacent to the manifold for easy servicing. A drip leg and/or filter should be provided upstream of the unit's inlet gas connection. An additional shut-off must be located external of the unit's enclosure. The location of this valve must comply with all local codes. A 1/8 inch N.P.T. plugged tapping, accessible for test gauge connection, must be installed immediately upstream of the gas supply connection to the unit.

**WARNING: To avoid equipment damage or possible personal injury, disconnect gas piping to this unit until a supply line pressure/leak test has been completed. Connecting the unit before completing the pressure/leak test may damage the unit gas valve and result in a fire hazard.**

**DANGER: Never use an open flame to detect gas leaks. Explosive conditions may exist which would result in personal injury or death.**

On vertical units there is a factory installed "Burner Cleanout" pipe located on the opposite end of the gas piping compartment. This is a clean out to drain any condensate that may have collected in the line burner.

**WARNING: DO NOT connect supply gas to this pipe.**

The gas line should be supported so that no strain is placed on the unit. Pipe compounds which are not soluble to liquid petroleum gases should be used on threaded joints.

Refer to the heater's rating plate for determining the minimum gas supply pressure for obtaining the maximum gas capacity for which this heater is specified.

Une tuyauterie adéquatement dimensionnée doit être posée jusqu'à l'unité. Veuillez noter que la pression de la tuyauterie d'alimentation en gaz doit correspondre à celle spécifiée sur la plaque d'identification, lorsque l'unité fonctionne à plein rendement.

Refer to the heater's rating plate for determining the maximum supply pressure to the heater.

**The appliance and its individual shutoff valve must be disconnected from the gas supply piping system during any pressure testing of that system at test pressures in excess of 1/2 PSIG.**

**The appliance must be isolated from the gas supply piping system by closing it's individual manual shutoff valve during any pressure testing of the gas supply piping system at test pressure equal to or less than 1/2 PSIG.**

Correctly sized piping must be run to the unit.

**Please note that gas line pressure must be as shown on specification plate when unit is operating at full input. The high-pressure regulator and relief valve should be, if possible, mounted at least 5 to 10 feet upstream from the appliance regulator on the unit (if possible).**

**Building Pressure Transducer Piping (PT-13)**

Pipe the high side to location inside the building that will not be affected by air movement. Pipe the low side to the atmosphere, positioned so it will not be affected by the wind and not exposed to the elements. Be sure that all tubing is clean and clear of any debris before installing tubes on the transducer.

**Flow Station Transducer Piping (PT-15)**

Pipe the high side to the upstream connection and low side to the downstream connection of the Airflow Station as shown in Drawing # C000643 below. Be sure that all tubing is clean and clear of any debris before installing tubes on the transducer.

**G. Field Wiring and Remote Control Installation**

1. Connect the power lines to the line side of the power distribution block or optional main disconnect switch.

2. Field wiring is typically indicated on the wiring diagram as dashed lines. When running any field wiring for control circuit be sure wire is sized for a maximum 10% voltage drop. Check the VA rating of control circuit transformer to determine maximum load.
3. Mount and wire remote control panel, thermostats, temperature sensors, and any other field installed controls as indicated on the unit control wiring diagram.
4. Connect all wires to the appropriate field wiring terminals and any shielded or twisted wires as indicated on the unit control diagram.
5. Field wiring shall have a temperature rating of at least 105°C. The minimum size of the supply cable circuit shall be sufficient for the maximum ampacity of the heater.

L'installation électrique d'utilisateur aura une température qui évalue d'au moins 105°C. La minimum de source du circuit de câblage sera suffisante pour le ampacity maximum de l'appareil de chauffage.

**H. Locating Temperature Controls**

The room or outdoor sensors should be mounted where they will not be subjected to direct impact of the heated air or radiant heat from the sun. It is also recommended that thermostats, especially those with mercury bulb contacts, be mounted on a vibration free surface. The side of building columns away from the heater or interior walls are usually the location best suited for mounting thermostats.

Controls with outdoor sensors require that the outdoor sensor be shielded from direct radiation from the sun. Unit mounted sensors are factory located and mounted.

**AIRFLOW STATION LAYOUT**

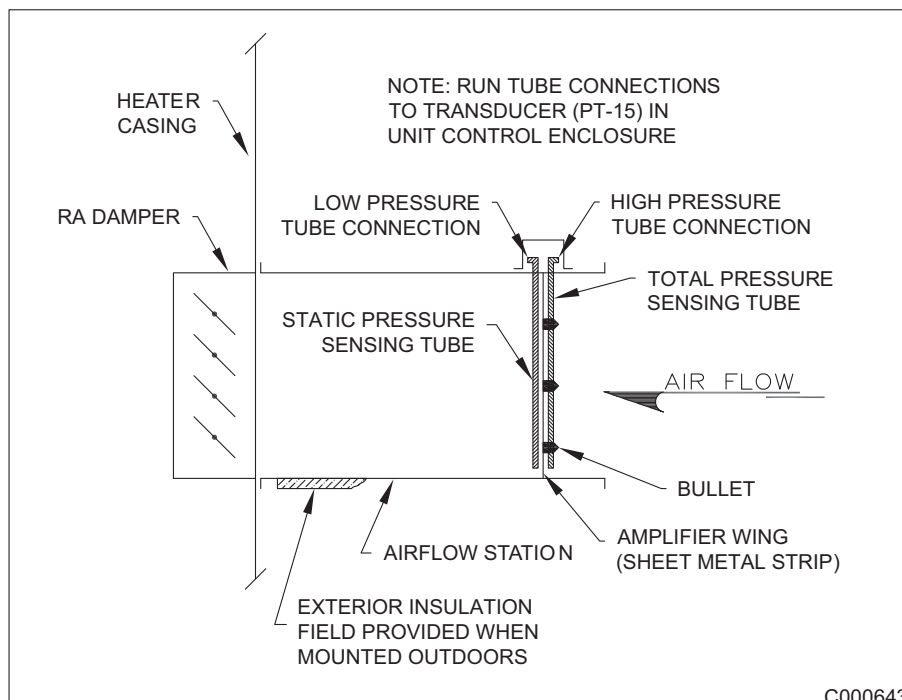

## SECTION IV - PRE START-UP

**Do not attempt start-up without completely reading and understanding this manual, along with the Digital Control System user manual.**

### A. Pre Start-Up

The owners representative or equipment operator should be present during start-up to receive instructions on care and adjustments of the equipment.

All equipment has been factory tested, adjusted, metered and inspected to meet conditions set at the time the order was placed. Only minimal adjustments should be required. All information in this service manual is typical. All products are semi-custom and changes may occur.

### Suggested Tools and Instruments

Volt/Ohm Meter	Thermometer
Tachometer	Ammeter
Manometer (0-10" W.C.)	Microammeter
Standard Hand Tools	D.C. Volt Meter
Gas Pressure Gauge (0-35 lbs.)	BACview 6 or Equipment Touch

**CAUTION: Line side of disconnect may be energized. Follow proper "lockout/tagout" procedures.**

**NOTE: All servicing and adjustments of the Direct Gas-Fired unit should be performed by a qualified service engineer.**

Perform a visual inspection, internally and externally, to make sure no damage has occurred and that everything is secure. This inspection is very important and should be completed with greatest care given to detail. A good pre-start inspection will insure against possible unit damage on start-up and will save valuable analysis time.

1. Check that the physical condition of the unit exterior is acceptable.
2. Check that the insulation inside of unit is properly secured.
3. Remove all shipping blocks, brackets and bolts from supply fan base with optional isolation base.
4. Check all wiring for loose connections and tighten if necessary.
5. Inspect all fan and motor bearings and lubricate if necessary.

**CAUTION: DO NOT RUPTURE GREASE SEALS.**

6. Inspect pulleys and belts for tightness, tension and alignment. **Do not overtighten belts.**
7. Check set screws on all bearings, pulleys, fans and couplings for tightness.
8. Check voltage supplied to disconnect switch; the maximum voltage variation should not exceed  $\pm 10\%$ . Phase voltage unbalance must not exceed 2%.

9. Check thermostat(s) for normal operation.
10. Check that system duct work is installed and free from obstructions.
11. Check that fans turn free in housing.
12. Check that the area around the unit is clear of flammable vapors or containers of flammable liquids.
13. Check that all piping connections, particularly unions, are tight. Check all gas piping for leaks using a soap bubble solution. The most common types of problems found relative to the gas train itself is foreign material within the gas piping. This will interfere with the proper operation of the gas train components and burner. Purge all air from gas lines per gas codes.
14. Check that all accessories requiring field wiring have been properly installed.
15. Check burner for proper location and alignment.
16. Check that filters, filter stops, accessories and ship loose items are installed correctly.
17. Check that vent lines (if applicable) are run to atmosphere on gas regulators and pressure switches for indoor units. Vent lines should terminate outside the building, with a turndown elbow and bug screen. Note that some units will use vent limiters and vent lines are not required. If vent lines are even partially plugged, this will interfere with proper venting of pressure control devices.
18. Check that all manual gas shut-off valves are closed.
19. When failure or malfunction of this heater creates a hazard to other fuel burning equipment, (e.g. when the heater provides make-up air to a boiler room), the heater is to be interlocked to open inlet air dampers or other such devices.
20. Motor overload relay setting should match the motor's nameplate full load amperage.
21. Check that dampers and linkages are free to move, and that linkages are tight.
22. The unit may require that a Return Airflow Station be field installed. Be sure all tubing connections are in the correct location as shown in drawing #C000643.
23. Check to ensure all manual reset safety devices have been reset and limits are in the normal operating position.
24. **If inlet duct is attached to the heater, a purge timer must be provided and set to purge 4 times the inlet duct volume.**

**Purge time in seconds =  $\frac{4 \times L \times W \times H \times 60}{\text{SCFM}}$**

**L = duct length in feet, W = duct width in feet, H = duct height in feet, SCFM = rating plate air throughput.**

**Refer to the electrical schematic for the proper circuit placement. Purge timer P/N 65.0711.00.**



## SECTION V - UNIT START-UP GENERAL

Before attempting to start the heater read and understand the the sequence of operations electrical schematic, ignition module, control components, gas train, burner and the Digital Control System user manual.

**WARNING: During installation, testing, servicing and trouble shooting of this product, it may be necessary to work with live electrical components. Have a qualified licensed electrician or other individual who has been properly trained in handling live electrical components to perform these tasks. Failure to follow all electrical safety precautions when exposed to live electrical components could result in death or serious injury.**

Make sure all manual gas valves are closed.

Make sure all doors and service panels have been closed or replaced.

Turn main disconnect switch off. Check the incoming line voltage to match unit rating plate rating. If voltage is over  $\pm 10\%$  of nameplate rating or phase voltage unbalance is over 2%, notify contractor or power company.

### Fans Are Enabled And Disabled By The Following:

#### MDT And MRT Standard:

By rotating the remote “Temperature Setpoint” knob (MP-15).

Clockwise will **enable** the fans.

Counterclockwise will **disable** the fans.

#### MRT-PRO With Smart Room Sensor:

To **enable** the fans and place the unit in the Occupied Mode press the “Manual On” button on the face of the (TS-02) MRT-PRO room sensor. Pressing the “Warmer” button will add 30-minute increments of time for a total of 9-hours of operating time. To **disable** the fans and place unit in the Unoccupied Mode press and hold down the “Manual On” button. Alternately pressing the “Manual On” button will also decrease the amount of operating time until it reaches zero and turns the fan off.

#### MRT Expert or VDT Expert With A BACview (KP-01):

To **enable** the fans go to “Unit Modes” and enter [MANUAL], this mode will enable the fans.

To also **enable** the fans go to “Unit Modes” and enter [AUTO], this mode has four different functions that control the fans and unit operation. They are a Time Clock, Heating and Cooling Night Setbacks, and signal from an external source to an auxiliary digital input.

To disable the fans go to “Unit Modes” and enter [OFF].

#### MRT-Touch or MDT-Touch with an Equipment Touch (KP-02):

To **enable** the fans, go to the Modes screen and change the Unit Mode to **Manual**. This mode will enable the fans.

To also **enable** the fans, go to the Modes screen and change the Unit Mode to **Auto**. This mode has five different functions that control the fans and unit operation. They are a Time Clock, Heating and Cooling Night Setbacks, a signal from an external source to an auxiliary digital input, and a network enable signal from a building automation system.

To **disable** the fans, go to the **Modes** screen and change the Unit Mode to **Off**.

**NOTE: A BACview 6, Equipment Touch, or PC is required to change Unit Modes. For a more detailed control sequence see the (Digital Control System User Manual).**

Turn main disconnect switch on and Enable fans. Damper opens (if applicable). After end switch has proven damper is open, the blower fan turns on. (see operating modes in Digital Control System user manual)

Disable the fans. Check supply blower for proper rotation.

**NOTE: To change rotation of the blower, simply interchange any two (2) of the line leads of the motor starter for three (3) phase motors. On single phase motors refer to motor nameplate.**

Enable the fans. Check for proper blower rpm. Check that all motor amp draws do not exceed rating plate ratings and overloads are set to motor rating plate amps.

Check all dampers for proper operation, and linkage does not bind, see “Sequence of Operation”, and Digital Control System user manual for damper control modes.

Disable the fans.

**NOTE: Before attempting to light the main burner you need to review Section X for proper Manifold and Valve Adjustments. A BACview 6, Equipment Touch, or PC will be required to change setpoints.**

Check the gas supply pressure by replacing the plug fitting on the gas line with a pressure gauge having appropriate range, and opening the manual gas valve. Check that the pressure reading is within the specified range on the rating plate.

**NOTE: To adjust gas pressure on supply lines where a regulator has been installed (to reduce the inlet pressure to rating plate maximum pressure), remove dust cap of main gas regulator and turn adjusting screw clockwise to increase pressure or counter-clockwise to decrease pressure.**

Connect a DC Microammeter between SENSE terminal and flame rod sensing wire.

Open first main gas shut-off valve **slowly**. Reset high-low gas pressure switches (if applicable). Check main gas line for leaks using soap solution.

### Heat is Enabled By The Following:

#### MDT And MRT Standard:

To **enable** the heat, rotate the “**Temperature Setpoint**” knob (**MP-15**) clockwise to the desired setpoint above the actual air temperature. The allowable temperature range is 55° to 90°F.

#### MRT-PRO With Smart Room Sensor:

To **enable** the heat, press the “**Warmer**” or “**Cooler**” button on the face of the remote **MRT-Pro** room sensor (**TS-02**) to the desired room setpoint. Each push of the button changes the temperature setpoint by 1° F. The setpoint can be changed a maximum of  $\pm 10^\circ\text{F}$  from the default of 65°F. **Changing the heating setpoint also changes the cooling setpoint.**

#### MRT Expert or VDT Expert With A BACview (KP-01):

To enable the heat for MRT Expert scroll through the “Setpoints” menu in the BACview and enter the desired room Heating Occupied and Unoccupied Setpoints. For VDT Expert enter the desired Heating Discharge Air Setpoint.

#### MRT-Touch or MDT-Touch with an Equipment Touch (KP-02):

To **enable** the heat, go to the **Setpoints** screen in the Equipment Touch and enter the desired Heating Occupied and Night Setback setpoints.

#### Energy Savings Modes:

**There are 3 Energy Savings Modes that could disable the burner.**

**NOTE: A BACview 6, Equipment Touch, or PC is required to change Setpoints. For a more detailed control sequence, see the Digital Control System Users Manual.**

#### Setting Main Flame

**CAUTION: You will have approximately three (3) to nine (9) minutes (user-configurable by adjusting the Freezestat Buffer Time setpoint) before the unit shuts down on Freezestat (Low Discharge Temperature), if you have disconnected plug wires TS-01 and TS-03. Referred to in Section X.**

**NOTE: 3 OR 4 TRIALS MAY BE NEEDED TO PURGE AIR FROM GAS LINE.**

#### United Technologies Electronic Controls Spark Ignitor (RE-02)

Watch microammeter carefully. Burner must hold in low fire for approximately 10 seconds before modulating up. The reading should be at least 0.5 microamps. If the reading is too low, slowly turn the low-fire adjustment on the modulating valve in or out until satisfactory readings are obtained. When adjusting low fire, there should be a continuous flame along the entire burner length without any blowout spots.

Install manometer at test port on the last tee of the burner manifold, or MR valve test port.

**Slowly** open last manual gas shut-off valve.

Enable the fan and burner. Unit will run for 5 seconds before valve opens and burner lights if all safeties and limits are in normal operating mode.

**NOTE: This is a direct spark ignition burner. Low fire may need to be adjusted first in order to light the burner.**

Adjust high fire pressure reading (from manometer) to match Normal Manifold Pressure firing rate shown on unit rating plate.

**Refer to Valve Adjustment instructions in Section X for setting high and low fire gas pressure settings.**

The high fire setting must be made before adjusting low fire. Adjust the high fire setting according to the Maxitrol Valve Adjustment instructions in Section X. The high fire setting **must not** exceed the pressure stated on the rating plate.

**When adjusting low fire, there should be a continuous flame along the entire burner length without any blowout spots.** Burner must hold in low fire for approximately 10 seconds before modulating up.

Check flame signal with burner cycling through full firing range.

Cycle burner several times to insure smooth light off. Low fire may need to be readjusted.

There should be a continuous spark for ten (10) seconds with the last gas cock turned off and the ignition control (RE-02) should lock out.

Check main gas lines for leaks.

Main flame is now set. Make sure burner modulates and turn thermostat to the desired setting.

## Safety Controls Check All

A. Ignition Control (RE-02) – Close last manual gas valve before main burner. Operate unit in Heat mode. The ignition control must lock out within approximately 15 seconds.

B. High Temperature Limits and Firestats – These limit controls are not adjustable and are checked at the factory. Reset the button(s) to be sure they are ready for operation. Contact factory if these switches fail to reset.

C. Gas Pressure Switches – The low pressure switch will trip out and must be reset before resuming operation when the inlet gas valve is turned off during operation. The high pressure switch may be checked out by reducing the setting of its trip point to unit operating pressure. It should then trip out and shut off the burner. Return the adjustment to its original setting and reset to resume operation.

D. Air Pressure Switches – The high air pressure switch is checked by removing the sensing tube from the entering air side of the burner and gently blow into the switch connection. Switch operation will shut off the burner. Recycle is automatic when the sensing tube is replaced. The low air pressure switch is checked by removing the sensing tube from the leaving air side of the burner. Switch operation will shut off the burner. Recycle is automatic when the sensing tube is replaced. **Do not adjust air flow switches.**

E. Adjustable temperature and limit Controls – The limit controls are checked by adjusting control settings to a lower temperature setting while the unit is operating on high fire and observing cutoff. The controls should be reset to settings shown below:

**Make sure all the safeties and controls are working properly.**

## Suggested Control Settings

(Refer to Digital Control System user manual for default settings)

TS-02	Space Temperature Sensor.....	Customer Discretion
KP-01	Keypad/Display Module.....	Customer Discretion
KP-02	Touchscreen Module.....	Customer Discretion
MP-05	Damper Control Potentiometer ...	Customer Discretion
MP-15	Unit Enable Potentiometer .....	Customer Discretion
PS-04	Low Gas Pressure Switch .....	1.0" W.C.
PS-07	High Gas Pressure Switch .....	125% above burner firing rate
PS-12	Clogged Filter Switch .....	Adjust to field condition
PT-13	Building Pressure Transducer...	Adjust to field condition
FL-02	High Temperature Limit (Manual) .....	185° F

### Cooling is Enabled By The Following:

#### MDT And MRT Standard:

To enable the **cooling**, rotate the “**Temperature Setpoint**” knob (MP-15) clockwise to the desired setpoint below the actual air temperature. The allowable temperature range is 55° to 90°F.

#### MRT-PRO With Smart Room Sensor:

To **enable** the cooling, press the “**Warmer**” or “**Cooler**” button on the face of the remote **MRT-Pro** room sensor (**TS-02**) to the desired room setpoint. Each push of the button changes the temperature setpoint by 1° F. The setpoint can be changed a maximum of  $\pm 10^\circ\text{F}$  from the default of 73°F. **Changing the cooling setpoint also changes the heating setpoint.**

#### MRT Expert or VDT Expert With A BACview (KP-01):

To **enable** the cooling for MRT Expert scroll through the “**Setpoints**” menu in the BACview and enter the desired room **Cooling Occupied and Unoccupied Setpoints**. For VDT Expert enter the desired Cooling Discharge Air Setpoint.

#### MRT-Touch or MDT-Touch with an Equipment Touch (KP-02):

To **enable** the cooling, go to the **Setpoints** screen in the Equipment Touch and enter the desired Cooling Occupied and Night Setback setpoints.

#### Energy Savings Mode:

**Energy Savings Mode 4 can disable the cooling.**

**NOTE: The cooling outputs are protected by an anti-cycle timer which has a 3 minute off/3 minute on delay. A BACview 6, Equipment Touch, or PC is required to change Setpoints. For a more detailed control sequence, see the Digital Control User Manual.**

## SECTION VI - UNIT SHUTDOWN

### A. Extended Shutdown —

1. Disable the heating and cooling for 30 seconds, then disable the fan.
2. Close all manual gas valves.
3. Open the main electrical disconnect switch.

### B. Emergency Shutdown ONLY —

1. Open the main electrical disconnect switch.
2. Close the main manual gas valve.

## SECTION VII - TROUBLE SHOOTING

### Check Safety Shutdown Performace

**WARNING: Fire or explosion hazard. Can cause property damage, severe injury or death. Perform the safety shutdown test any time work is done on a gas system.**

**NOTE: Read steps 1 through 7 before starting, and compare to the safety shutdown or safety lockout tests recommended for the intermittent ignition module. Where different, use the procedure recommended for the module.**

1. Turn off the last manual gas cock.
2. Adjust setpoint above room temperature to call for heat.
3. Watch for ignition spark following prepurge. See ignition module specifications.
4. Time the length of the spark operation. See the ignition module specifications.
5. After the module locks out, open the manual gas cock and make sure no gas is flowing to the main burner.
6. Reset the ignition control relay (RE-02).
7. Operate system through one complete cycle to make sure all controls operate properly.

### United Technologies Electronics Control Operation of the Series 1016-400 Direct Spark Ignition Control (RE-02)

On a call for heat a five second pre-purge is initiated. Upon completion of the pre-purge, the gas valve and 60Hz spark are energized. When flame is detected, the control enters the steady state heating condition. Steady state heating will continue until the call for heat is satisfied.

If ignition is not achieved within 15 seconds, the control shuts off the gas and locks out. If the trial for ignition has been accomplished without ignition, the control shuts off all outputs and enters lockout. Reset is accomplished by cycling the power off for a minimum of 5 seconds. If flame is lost once it has been established, the control will shut off the gas valve within 0.8 seconds and locks out.

If flame is sensed during a purge period when no flame should be present, the control will remain in purge with the gas valve off until the false flame disappears. If the gas valve is found to be powered when it should be off, or not powered when it should be on, the ignition control will enter lockout with all outputs off. Reset is accomplished by cycling the power off for a minimum of 5 seconds.

The Red LED Diagnostics codes are:

- |             |  |
|-------------|--|
| Steady Off: | No power or control hardware fault       |
| Steady On:  | Power applied, control OK                |
| 1 Flash:    | Burner failed to light                   |
| 2 Flashes:  | Flame was established but then went out. |
| 3 Flashes:  | Control hardware fault detected          |

This equipment has been electrically and fire tested prior to shipment. However, during transit control setpoints can change, and wiring can come loose. Do not assume controls are defective until all associated setpoints and wiring are checked.

**If you do not have the optional BACview 6 (KP-01) keypad display or Equipment Touch (KP-02) touchscreen display it will be difficult to troubleshoot any alarm that may occur on the unit. To reset most alarms on the I/O Zone 583 Controller (UC-01) without a BACview 6 keypad or Equipment Touch touchscreen, simply turn the power off and back on at the unit disconnect. If you have a BACview 6 keypad or Equipment Touch touchscreen the alarm can be reset remotely or at the I/O Zone 583 Controller.**

The following is a simplified list of possible problems and typical causes and remedies. However, it does not cover all possibilities, and is intended as a guide only. **You might also need to reference the Digital Control System User Manual for additional troubleshooting and diagnostics.**

**WARNING: Many of the steps listed on the following pages require electrical cabinet and blower access while the unit is powered. High voltage and moving parts are present, and these steps should be performed by qualified service personnel. If any of the controls requiring manual reset were at fault this is an indication of a problem with the system that should be investigated.**

**SECTION VII - TROUBLESHOOTING** *continued*

**Fan and Heat Mode**

Symptom	Cause	Remedy
<p>A. If blower does not operate.</p>	<ol style="list-style-type: none"> <li>1. Low or no voltage.</li> <li>2. Fuse(s) blown.</li> <li>3. Customer interlock not closed or connected.</li> <li>4. Fan is disabled.</li> <li>5. Time clock, night setback thermostat, or field installed controls open.</li> <li>6. Freeze protection tripped. (low discharge temperature)</li> <li>7. Damper motor not operating, its end switch not making, or the damper is binding.</li> <li>8. Overload Protection on motor starter tripped.</li> <li>9. Belts loose or broken.</li> <li>10. Bearings seized.</li> <li>11. Motor may be burned or incorrectly wired.</li> <li>12. Blower motor overheating.</li> <li>13. DO-1 on UC-01 not energized.</li> <li>14. Door switch open.</li> </ol>	<ol style="list-style-type: none"> <li>1. Check power source.</li> <li>2. Check and replace.</li> <li>3. Close or connect customer interlock.</li> <li>4. Enable the fan.</li> <li>5. Check time clock, night setback thermostat and field installed controls for proper settings.</li> <li>6. Reset freeze stat by interrupting power. Check for proper setting and burner operation.</li> <li>7. Check for power at damper motor and that end switch has been wired correctly to the N.O. (normally open) contact. Check that the linkage is clear and not binding.</li> <li>8. Push reset button on starter and check amps.</li> <li>9. Turn power off and check belts.</li> <li>10. Check and replace.</li> <li>11. Turn power off and check motor and wiring.</li> <li>12. Check burner firing rate.</li> <li>13. See Digital Control System User Manual.</li> <li>14. Close door. Check and/or replace.</li> </ol>
<p>B. If there is no voltage at ignition control (RE-02) input terminal and the fan is enabled.</p>	<ol style="list-style-type: none"> <li>1. Heat mode is disabled.</li> <li>2. Auxiliary switch on starter not closed (ST-01).</li> <li>3. Air flow switches open.</li> <li>4. Outside air temperature higher than Heating Economizer Setpoint.</li> <li>5. High temperature limit thermostat open.</li> <li>6. High-low gas pressure switch open. (If applicable)</li> <li>7. Field purge timer open. (If applicable)</li> <li>8. DO-2 on UC-01 not energized.</li> </ol>	<ol style="list-style-type: none"> <li>1. Enable the heating mode.</li> <li>2. Check auxiliary circuit wiring and contact.</li> <li>3. Adjust the air flow and external static pressure to match the rating plate (Do not adjust switch setpoint).</li> <li>4. Check stat for proper setting.</li> <li>5. Reset control and correct problem before restarting.</li> <li>6. Check gas pressure and reset switch.</li> <li>7. Check for power or replace if necessary.</li> <li>8. See Digital Control System User Manual.</li> </ol>
<p>C. If the ignition control (RE-02) goes into safety shutdown (lockout).</p>	<ol style="list-style-type: none"> <li>1. See technical cut sheet on ignition control.</li> </ol>	<ol style="list-style-type: none"> <li>1. Determine the cause of (lockout). Recycle power.</li> </ol>

(Refer to Digital Control System User Manual for additional troubleshooting suggestions)



## SECTION VII - TROUBLESHOOTING *continued*

### Heat Mode *continued*

Symptom	Cause	Remedy
D. If burner does not light after prepurge has timed out (5 seconds) and voltage is present on ignition control input terminals.	<ol style="list-style-type: none"> <li>1. Manual shut-off valve closed.</li> <li>2. Inlet gas pressure lower than required gas pressure</li> <li>3. No gas through main gas regulator with inlet gas pressure ok.</li> <li>4. No gas through main gas solenoids.</li> <li>5. Type of gas (natural - LP) supplied different from factory required type. Note: components may change.</li> <li>6. Flame detection system not sparking or sensing flame. (see spark rod diagram #P-001117)</li> <li>7. No voltage output terminals of ignition control.</li> <li>8. Main gas valve relay open.</li> </ol>	<ol style="list-style-type: none"> <li>1. <b>Slowly</b> open valve.</li> <li>2. Increase gas pressure.</li> <li>3. Clear obstruction in vent orifice/line or replace if defective.</li> <li>4. Check for correct installation and voltage. Correct or replace.</li> <li>5. Replace with factory required type of gas.</li> <li>6. Flame Rod - assure rod is in flame, check wiring and flame rod.</li> <li>7. Check wiring or replace ignition control.</li> <li>8. Check for power, replace if necessary.</li> </ol>
E. Burner will not respond to temperature.	<ol style="list-style-type: none"> <li>1. For DDC System.</li> <li>2. For RTC RE-26.</li> </ol>	<ol style="list-style-type: none"> <li>1. See Digital Control System User manual.</li> <li>2. Refer to following troubleshooting guide for RTC controls.</li> </ol>
F. Mixing Box with Airflow Station dampers not functioning properly. See Sequence of Operation for damper control.	<ol style="list-style-type: none"> <li>1. Defective or misadjusted transducer (PT-15).</li> <li>2. Transducer (PT-15) wired incorrectly.</li> <li>3. Transducer (PT-15) tubing not installed correctly.</li> <li>4. Building Pressure Transducer (PT-13), Damper Control Potentiometer defective or not calibrated.</li> <li>5. Building Pressure Transducer (PT-13), Damper Control Potentiometer not wired correctly.</li> <li>6. Building Pressure Transducer (PT-13), Damper Control Potentiometer not installed correctly.</li> <li>7. Unit Control Module (UC-01) defective.</li> <li>8. Unit Control Module (UC-01) not wired correctly.</li> <li>9. Damper motor defective.</li> <li>10. Dampers binding and/or loose.</li> </ol>	<ol style="list-style-type: none"> <li>1. Check and/or replace. See section on troubleshooting PT-15.</li> <li>2. Check wiring.</li> <li>3. Install correctly. See section on airflow station layout.</li> <li>4. Check and/or replace components. See section on trouble shooting PT-13.</li> <li>5. Check wiring.</li> <li>6. Install correctly. See section on trouble shooting PT-13 and manufacturer's cut sheet.</li> <li>7. Check and/or replace. Contact Factory.</li> <li>8. Check wiring.</li> <li>9. Check and/or replace.</li> <li>10. Check and repair.</li> </ol>

(Refer to Digital Control System User Manual for additional troubleshooting suggestions)

## TROUBLESHOOTING GUIDE FOR AMPLIFIER (RE-26)

The SC-1 signal conditioner provides signal conversion for a high impedance 2-10VDC signal source to drive a 24VDC solenoid. The control should be powered by an isolated 24VAC transformer to drive up to a .5A dc solenoid.

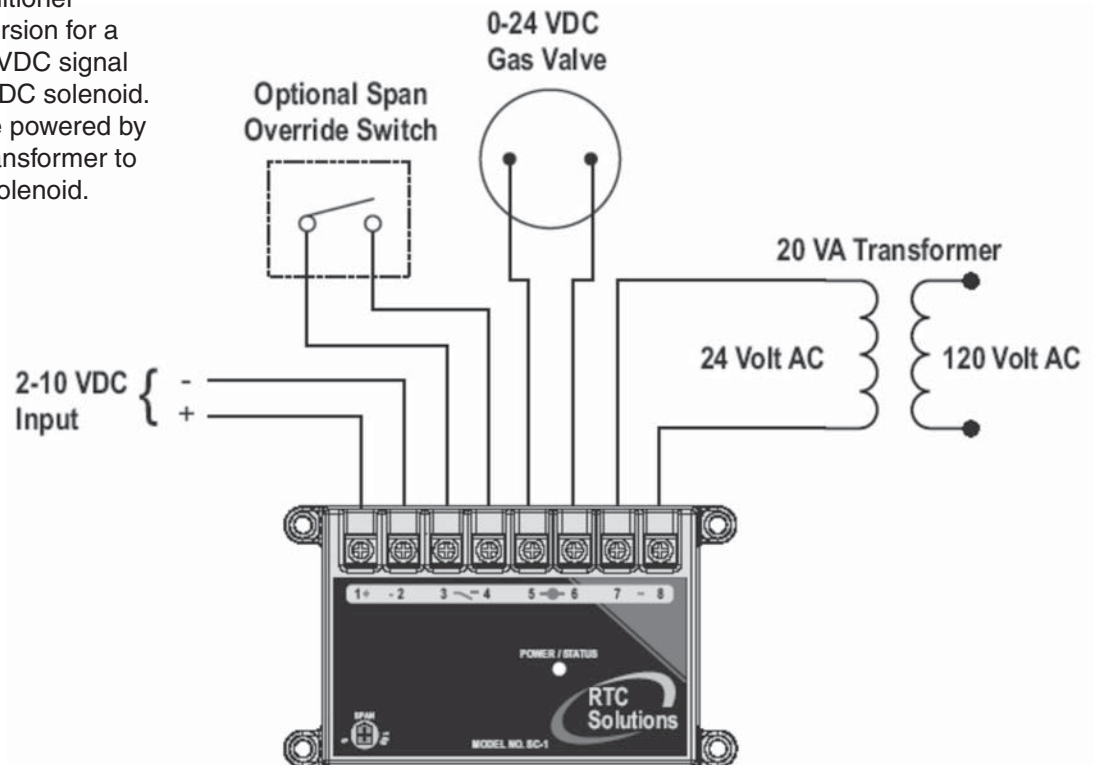

**Span Override Switch** - When terminals 3 & 4 are shorted together the span setting is ignored forcing the ratio to 100%.

**Start Up Delay** - The unit will pause for 10 seconds after power is applied to begin driving the output.

### **Power/Status LED**

A solid green LED indicates power and normal operation.

A slow blinking green LED indicates power but the 10 second start up delay has not completed.

A fast blinking green LED indicates the the inpput signal is out of range or may be reversed.

## TROUBLESHOOTING GUIDE

### Modulating Discharge Temperature (MDT, MDT-EXPERT, or MDT-TOUCH) Controls

Portions reproduced with permission from Maxitrol® Company

Symptom	Possible Cause	Field Test	Remedy
A. No Gas Flow with DO-2 on UC-01 energized.	1. Modulating valve improperly installed.	1. Arrow on side of valve should point in direction of gas flow.	1. Install properly.
B. Continuous Low Fire (Electronics Problem).	1. Short circuit or no voltage to the amplifier (RE-26). 2. Jumper not connected across amplifier (RE-26) terminals 3 & 4. 3. Faulty amplifier (RE-26).  4. No output voltage on UC-01.	1. Check for 24V AC at amplifier (RE-26) terminals 7 & 8. 2. Inspect.  3. Check item B1. Check for 2-10 VDC input signal from (UC-01) at terminals 1 & 2. Check for 0-20 VDC output signal to gas valve at terminals 5 & 6. 4. Check DC Voltage on AO-1.	1. Prove the power source.  2. Correct the wiring.  3. If item B1 checks out and modulating voltages are still not obtained, amplifier (RE-26) may be assumed faulty. Replace.  4. Contact Factory.
C. Continuous Low Fire (Electronics OK).	1. Short circuit or open circuit in Modulator Coil.  2. Plunger missing, jammed or improperly installed.	1. Measure resistance across modulator terminals with connecting wires detached.  2. Inspect. Plunger should be installed to operate freely in solenoid sleeve.	1. Replace modulator head if not approximately 45-55 ohms for M611 Valve and 60-80 ohms for MR212 Valve.  2. Clean or replace plunger if necessary.
D. Incorrect Minimum Fire Erratic or Pulsating Flame.	1. Incorrect by-pass metering valve adjustment. 2. Excessive negative burner pressure.	1. See valve adjustments in Section X.  2. Close main gas supply and measure manifold pressure with blower operating. Reading should be less than 1.5" w.c. negative pressure.	1. Adjust to proper minimum fire.  2. If reading is greater than 1.5" negative pressure, check for clogged filters or other inlet air restrictions. Consult factory for other solutions.
E. Continuous High Fire (Electronics Problem).	1. Open circuit in Outside Air Temperature Sensor (TS-01) or Discharge Air Temperature Sensor (TS-03) circuit or wiring.	1. Check Outside Air Temperature Sensor (TS-01) or Discharge Air Temperature Sensor (TS-03) for open internal circuit. See Thermistor curve.	1. Replace Outside Air Temperature Sensor (TS-01) or Discharge Air Temperature Sensor (TS-03)
F. Continuous High Fire (Electronics OK).	1. Foreign object holding valve open. 2. Plunger jammed.	1. Remove bottom plate and inspect valve and seat. 2. Inspect. Plunger should be smooth and clean and operate freely in solenoid sleeve.	1. Clean seat. Clean valve or replace if necessary.  2. Clean, or if necessary, replace plunger.

(Refer to Digital Control System User Manual for additional troubleshooting suggestions)

## TROUBLESHOOTING GUIDE

**Modulating Discharge Temperature (MDT, MDT-EXPERT, or MDT-TOUCH) Controls** *continued* Portions reproduced with permission from Maxitrol® Company

Symptom	Possible Cause	Field Test	Remedy
G. Incorrect Maximum Fire.	<ol style="list-style-type: none"> <li>1. Inlet pressure too low.</li> <li>2. Incorrect outlet pressure adjustment of Pressure Regulator.</li> </ol>	<ol style="list-style-type: none"> <li>1. Read pressure at inlet to modulating valve using a manometer with unit operating at full fire. Pressure should be equal to the sum of outlet pressure setting plus pressure drop of the valve.</li> <li>2. Read manifold pressure using manometer and compare with the pressure stated on the specification plate.</li> </ol>	<ol style="list-style-type: none"> <li>1. Increase inlet pressure if possible.</li> <li>2. See valve adjustments in Section X.</li> </ol>
H. Incorrect Discharge Air Temperature	<ol style="list-style-type: none"> <li>1. Unit Enable Potentiometer (MP-15) not set correctly.</li> <li>2. Discharge Air Temperature Sensor (TS-03) not reading correctly.</li> <li>3. The Heating Discharge Air Setpoint on VDT-EXPERT Control System is not set correctly.</li> </ol>	<ol style="list-style-type: none"> <li>1. Check setpoint on Unit Enable Potentiometer (MP-15)</li> <li>2. Check Discharge Air Temperature Sensor (TS-03) and wiring. See Thermistor curve.</li> <li>3. Check setpoint with BACview 6, Equipment Touch, or PC.</li> </ol>	<ol style="list-style-type: none"> <li>1. Change to correct setpoint setting.</li> <li>2. If readings are not correct, replace Discharge Air Temperature Sensor (TS-03) or repair wiring.</li> <li>3. Change to correct setpoint. See Digital Control System User Manual.</li> </ol>
I. Burned out Transformer.	<ol style="list-style-type: none"> <li>1. Short circuit in modulator coil.</li> <li>2. Short circuit between amplifier and modulator valve.</li> </ol>	<ol style="list-style-type: none"> <li>1. Measure resistance across modulator terminals with red lead wires disconnected.</li> <li>2. Inspect wiring.</li> </ol>	<ol style="list-style-type: none"> <li>1. Replace modulator head if less than 40 ohms.</li> <li>2. Correct wiring if short is found.</li> </ol>

(Refer to Digital Control System User Manual for additional troubleshooting suggestions)

## TROUBLESHOOTING GUIDE

**Modulating Room Temperature (MRT, MRT-PRO, MRT-EXPERT, or MRT-TOUCH) Controls** Portions reproduced with permission from Maxitrol® Company

Symptom	Possible Cause	Field Test	Remedy
A. No Gas Flow with DO-2 on UC-01 energized.	1. Valve improperly installed.	1. Arrow on side of valve should point in direction of gas flow.	1. Install properly.
B. Continuous Low Fire (Electronics OK).	1. Open circuit in modulator coil. 2. Plunger missing, jammed or improperly installed. 3. Ruptured main or balancing diaphragm.	1. Remove wires connected to amplifier terminals and measure resistance. MR212 (60-80 ohms), M611 (45-55 ohms). 2. Inspect - plunger should be installed to operate freely in solenoid sleeve. 3. Disassemble valve for inspection of internal parts.	1. If proper resistance values are not observed, replace modulator head or repair wiring. 2. Clean or replace plunger if necessary. 3. Replace diaphragm if ruptured.
C. Continuous Low Fire (Electronics Problem).	1. Short circuit or no voltage to the amplifier (RE-26). 2. Jumper not connected across amplifier (RE-26) terminals 3 & 4. 3. Faulty amplifier (RE-26). 4. No output voltage on UC-01.	1. Check for 24V AC at amplifier (RE-26) terminals 7 & 8. 2. Inspect. 3. Check item B1. Check for 2-10 VDC input signal from (UC-01) at terminals 1 & 2. Check for 0-20 VDC output signal to gas valve at terminals 5 & 6. 4. Check DC Voltage on AO-1.	1. Prove the power source. 2. Correct the wiring. 3. If item B1 checks out and modulating voltages are still not obtained, amplifier (RE-26) may be assumed faulty. Replace. 4. Contact Factory.
D. Incorrect Low Fire.	1. Incorrect by-pass metering valve adjustment. 2. Excessive negative burner pressure.	1. See Valve Adjustments Section X. 2. Close main gas supply and measure manifold pressure with blower operating. Should be less than 1.5" w.c. negative pressure.	1. Adjust to proper low fire. 2. If greater than 1.5" negative pressure, check equipment for clogged filters and other inlet air restrictions. For other solutions, consult factory.
E. Continuous Minimum Discharge Air Temperature.	1. Incorrect room temperature.	1a. Check Outside Air Sensor (TS-01), Space Temperature Sensor (TS-02) and Discharge Air Sensor (TS-03) for correct readings. See Thermistor curve. 1b. Check Space Temperature Sensor (TS-02) setpoint. 1c. Check Heating Occupied and/or Unoccupied setpoint.	1a. Replace Sensors if reading is incorrect or correct wiring. 1b. Change to correct setpoint. 1c. Change to correct setpoint.
F. Incorrect Maximum or Minimum Discharge Air Temperature.	1. Maximum or minimum heating discharge temperature setpoint not set correctly.	1. Install a BACview 6, Equipment Touch, or PC.	1. Change to correct setpoints.

(Refer to Digital Control System User Manual for additional troubleshooting suggestions)

**Control circuits external to MRT Controls can cause burner malfunction.**

**Always check manual valve to be certain gas is on, and check limit controls for normal operation.**



## TROUBLESHOOTING GUIDE

Modulating Room Temperature (MRT, MRT-PRO, MRT-EXPERT, or MRT-TOUCH) Controls *continued* Portions reproduced with permission from Maxitrol® Company

Symptom	Possible Cause	Field Test	Remedy
G. Continuous High Fire (Electronics OK).	<ol style="list-style-type: none"> <li>Foreign material holding valve open.</li> <li>Plunger jammed.</li> </ol>	<ol style="list-style-type: none"> <li>Remove bottom plate and inspect valve and seat.</li> <li>Inspect - plunger should be smooth and clean and operate freely in solenoid sleeve.</li> </ol>	<ol style="list-style-type: none"> <li>Clean, replace valve and/or seat if necessary.</li> <li>Clean, or if necessary, replace plunger.</li> </ol>
H. Continuous High Fire (Electronic problem).	<ol style="list-style-type: none"> <li>Open circuit in Outside Air Temperature Sensor (TS-01), Space Temperature Sensor (TS-02) or Discharge Air Temperature Sensor (TS-03)</li> </ol>	<ol style="list-style-type: none"> <li>Measure resistance per Thermistor Curve.</li> </ol>	<ol style="list-style-type: none"> <li>If readings are incorrect, replace Outside Air Temperature Sensor (TS-01), Space Temperature Sensor (TS-02) or Discharge Air Temperature Sensor (TS-03) or repair wiring.</li> </ol>
I. Incorrect High Fire.	<ol style="list-style-type: none"> <li>Inlet pressure too low.</li> <li>Incorrect outlet pressure adjustment.</li> </ol>	<ol style="list-style-type: none"> <li>Read inlet pressure at valve, using a manometer with heater operating at full fire. Pressure should be at least equal to the sum of: outlet pressure setting and pressure drop of the valve plus 1.0" w.c.</li> <li>Read outlet pressure using manometer and compare with the pressure stated on the specification plate.</li> </ol>	<ol style="list-style-type: none"> <li>Increase inlet pressure if possible or change to larger valve. Consult factory about possibility of using special spring to reduce pressure drop on selected installations.</li> <li>See Valve Adjustments -Section X.</li> </ol>
J. Continuous Maximum Discharge Air Temperature.	<ol style="list-style-type: none"> <li>Open circuit in Space Temperature Sensor (TS-02) or Discharge Air Temperature Sensor (TS-03).</li> </ol>	<ol style="list-style-type: none"> <li>Measure resistance per Thermistor Curve.</li> </ol>	<ol style="list-style-type: none"> <li>If readings are incorrect, replace Space Temperature Sensor (TS-02) or Discharge Air Temperature Sensor (TS-03) or repair wiring.</li> </ol>
K. Burned out Transformer. No Voltage to Amplifier.	<ol style="list-style-type: none"> <li>Short in modulator coil circuit.</li> <li>Short circuit between amplifier and modulator valve.</li> </ol>	<ol style="list-style-type: none"> <li>Measure resistance per item B1.</li> <li>Inspect wiring.</li> </ol>	<ol style="list-style-type: none"> <li>If proper resistances are not observed, replace modulator head or repair wiring.</li> <li>Correct wiring if short is found.</li> </ol>
L. Incorrect Space Temperature.	<ol style="list-style-type: none"> <li>Incorrect Maximum Heating Discharge Temperature Setpoint.</li> <li>Incorrect Minimum Heating Discharge Temperature Setpoint.</li> <li>Incorrect space setpoint.</li> <li>Insufficient burner capacity.</li> </ol>	<ol style="list-style-type: none"> <li>Check to see if heater is delivering at Maximum Heating Discharge Temperature Setpoint.</li> <li>Check to see if heater is delivering at Minimum Discharge Setpoint.</li> <li>3a. Check Unit Enable Potentiometer (MP-15) Setpoint.</li> <li>3b. Check Heating Occupied and/or Unoccupied setpoint.</li> <li>4. Check to see if heater is operating at high fire.</li> </ol>	<ol style="list-style-type: none"> <li>If desired temperature is not reached, increase Maximum Heating Discharge Temperature Setpoint.</li> <li>If desired Space Temperature is not reached, increase Minimum Heating Discharge Setpoint.</li> <li>3a. Change to correct setpoint.</li> <li>3b. Change to correct setpoint.</li> <li>4. If desired Space Temperature is not reached with heater at high fire, it may be undersized. Consult Factory.</li> </ol>

(Refer to Digital Control System User Manual for additional troubleshooting suggestions)

**Control circuits external to MRT Controls can cause burner malfunction.**

**Always check manual valve to be certain gas is on, and check limit controls for normal operation.**

## TROUBLESHOOTING GUIDE

### Cooling Mode

Symptom	Cause	Remedy
A. There is no voltage at cooling relays (RE-34) (RE-35) and/or (RE-33) and the fan is enabled.	<ol style="list-style-type: none"> <li>1. Cooling mode is disabled</li> <li>2. Auxiliary switch on starter (ST-01) is not closed.</li> <li>3. Air flow switches open.</li> <li>4. Cooling Changeover and/or Economizer Setpoints not set correctly.</li> <li>5. DO-3 and/or DO-4 are not energized.</li> </ol>	<ol style="list-style-type: none"> <li>1. Enable the cooling mode.</li> <li>2. Check auxiliary circuit wiring and contact.</li> <li>3. Adjust the air flow and external static pressure to match the unit rating plate. <b>DO NOT ADJUST SWITCHES.</b></li> <li>4. Change to correct setpoints. See Digital Control User Manual.</li> <li>5. See Digital Control System User Manual.</li> </ol>
B. Cooling relays (RE-34) (RE-35) and/or (RE-33) are energized and condensing unit or evaporative cooler is not on.	<ol style="list-style-type: none"> <li>1. Cooling relays (RE-34) (RE-35) and/or (RE-33) contacts are not closed.</li> <li>2. Cooling relays (RE-34) (RE-35) and/or (RE-33) contacts are not wired correctly.</li> <li>3. Compressors or evaporative pump not running.</li> </ol>	<ol style="list-style-type: none"> <li>1. Check and/or replace.</li> <li>2. Correct wiring.</li> <li>3. See Troubleshooting Guide for your condensing unit or evaporative cooler.</li> </ol>
C. Incorrect Space Temperature.	<ol style="list-style-type: none"> <li>1. Incorrect Maximum Cooling Discharge Temperature Setpoint.</li> <li>2. Incorrect Minimum Cooling Discharge Temperature Setpoint.</li> <li>3. Unit Enable Potentiometer (MP-15) not set correctly.</li> <li>4. Cooling Occupied and/or Unoccupied setpoints not set correctly.</li> <li>5. Insufficient cooling.</li> <li>6. Condensing section or evaporative cooler is not operating correctly.</li> </ol>	<ol style="list-style-type: none"> <li>1. Decrease Maximum Cooling Discharge Temperature Setpoint. See Digital Control System User Manual.</li> <li>2. Decrease Minimum Cooling Discharge Temperature Setpoint. See Digital Control System User Manual.</li> <li>3. Change to correct setpoints. See Digital Control System User Manual.</li> <li>4. Change to correct setpoint settings. See Digital Control System User Manual.</li> <li>5. If desired Space Temperature is not reached and cooling is at full capacity, it may be undersized.</li> <li>6. See Troubleshooting Guide for your condensing unit or evaporative cooler.</li> </ol>

(Refer to Digital Control System User Manual for additional troubleshooting suggestions)

## TROUBLESHOOTING GUIDE

### To Calibrate the Building Pressure Transducer (PT-13)

1. Disconnect the tubes from the transducer.
2. **Make sure the Low and High fittings are clean and clear (do not insert any sharp objects into the pressure fittings). Make sure the tubing is also clean and clear of any debris.**
3. Connect the High and Low ports on the transducer together with a short length of tubing. Do not allow any kinks in the tubing.
4. Place the rotary switch into the [+/-] position. The current directional mode will show on the display. Press the NEXT button until -bl shows on the display.
5. Place the rotary switch in the [OUT] position. Press the NEXT button until 0 – 5 shows on the display.
6. Place the rotary switch into the [0] position. The display will show Aut0.
7. Press the NEXT button. The display will show a series of progress bars starting with one bar and ending with four. When the Auto Zero process is complete, the display will show “done” for approximately 4 seconds, then Aut0.
8. The voltage at Voltage Out and Gnd/4-20mA Out should now be 2.5 VDC.
9. Return the rotary switch to the [R1] position.
10. Reinstall the tubes on the transducer. **It is very important that the High tube be placed inside the building, and positioned so that air movement does not affect it. The Low side should be to atmosphere, and positioned so it is not exposed to the weather.**
11. With the use of a BACview 6 (KP-01) or Equipment Touch (KP-02) place the unit in the Building Pressure mode. (See the Digital Control System User Manual).
12. The voltage at Voltage Out and Gnd/4-20mA Out will vary between 0 to 5 VDC. 0 VDC means the building is in a negative pressure and should open the Outside Air/Profile Damper and close the Return Air Damper. 5 VDC means the building is in a positive pressure and should open the Return Air Damper and close the Outside Air/Profile Damper.

PT-13			
Bapi P/N	Mestex P/N	Range	Rotary Switch Position
ZPS-LR-EZ-NT-IN	68.0330.82	± 0.1 IN WC	R1



### To calibrate the Flow Station Pressure Transducer (PT-15)

1. Note the current rotary switch position (R1, R2, or R3) on the flow station pressure transducer (PT-15). You will need to return the rotary switch to this position after completing the following calibration steps.
2. Disconnect the tubes from the transducer.
3. **Make sure the Low and High fittings are clean and clear (do not insert any sharp objects into the pressure fittings). Make sure the static pressure sensing pitot tubes and all tubing is also clean and clear of any debris.**
4. Connect the High and Low ports together with a short length of tubing. Do not allow any kinks in the tubing.
5. Place the rotary switch into the [+/-] position. The current directional mode will show on the display. Press the NEXT button until -Unl shows on the display.
6. Place the rotary switch in the [OUT] position. Press the NEXT button until 0 – 5 shows on the display.
7. Place the rotary switch into the [0] position. The display will show Aut0.
8. Press the NEXT button. The display will show a series of progress bars starting with one bar and ending with four. When the Auto Zero process is complete, the display will show “done” for approximately 4 seconds, then Aut0.
9. The voltage at Voltage Out and Gnd/4-20mA Out should be 0 VDC.
10. Return the rotary switch to the position you noted in the first step of this procedure.
11. Reinstall the tubes on the transducer. It is very important that the Low and High tubes from the Flow Station are installed on the transducer correctly (see drawing #C000643 on page 7).
12. With the use of a BACview 6 (KP-01) or Equipment Touch (KP-02) place the unit in the Calibration mode. (See the Digital Control System User Manual). You can also short across the TS-01 and TS-03 terminals on UC-01 for ten (10) seconds. This will open the Return Air damper and close the Outside Air damper. The unit will calibrate for 5 minutes. **IMPORTANT:** Be sure there is no blockage in the return air duct.
13. The voltage at Voltage Out and Gnd/4-20mA Out should be at least 2 VDC. If the voltage is less than 2 VDC contact the factory.

PT-15			
Bapi P/N	Mestex P/N	Range	Rotary Switch Position
ZPS-LR-EZ-NT-IN	68.0330.82	0 – 0.1 IN WC	R1
		0 – 0.25 IN WC	R2
		0 – 0.5 IN WC	R3

## TROUBLESHOOTING GUIDE

### Checking The Burner Velocity Pressure

**PS-10 & PS-11 air switches are factory calibrated. Do not adjust.**

Check the velocity pressure by disconnecting both pressure sensing tubes from one of the high airflow switch. Connect one end of your manometer to each sensing tube and start the fan. The permissible pressure range should be marked on the switches. If it's close to the high or low trip points of the airflow switches, you could have a problem: High pressure switch open means too much velocity; low pressure switch open means not enough velocity.

Jumper the switch from which you've disconnected the sensing tubes and get the burner running in high fire. Your differential pressure should have dropped. If it is near the low switch trip point you need more air.

Some adjustments can be made by repositioning the burner profile plates. If the high switch is open, you can open the profile plates. If the low switch is open you can close the profile plates. Remember to keep the distance between the burner and profile plates the same opening on both the top and bottom of the burner when making these adjustments.

Depending on the motor amps you may want to change the speed of the fan if the unit has adjustable sheaves.

Don't forget to remove the jumper and reconnect the sensing tubes to the switch.

Call factory with any questions.

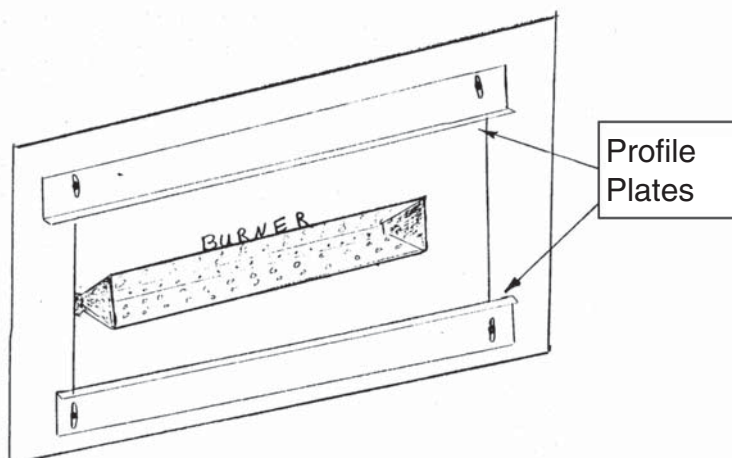

### MULTIPLEXED VOLTAGE CHART

RESISTOR VALUE	RESISTOR ID	SWITCH CLOSED	OHMS IN CIRCUIT	VOLTS DC
1000	RS1	RS1,2,3,4	0	0
2000	RS2	RS2,3,4	1000	0.30
4020	RS3	RS1,3,4	2000	0.55
8060	RS4	RS3,4	3000	0.76
<b>MULTIPLEXED VOLTAGE VALUES</b>		RS1,2,4	4020	0.95
		RS2,4	5020	1.10
		RS1,4	6020	1.24
		RS4	7020	1.36
		RS1,2,3	8060	1.47
		RS2,3	9060	1.57
		RS1,3	10060	1.65
		RS3	11060	1.73
		RS1,2	12080	1.80
		RS2	13080	1.87
		RS1	14080	1.92
		NONE	15080	1.98
		UNPLUGGED	NA	3.30

IN-3	JUMPER	RS-04	MIXED AIR TEMP
	RE-56	RS-03	SAFETY CKT STATUS
	RE-09	RS-02	FLAME FAILURE
	SW-72	RS-01	100% OA or 100% OUTPUT
IN-4	RE-27	RS-04	BURNER STATUS
	RE-65	RS-03	FAN STATUS
	RE-12	RS-02	CLOGGED FILTER
	SW-09	RS-01	AUXILIARY UNIT ENABLE



## SECTION VIII - MAINTENANCE SCHEDULE AND LUBRICATION REQUIREMENTS

**WARNING: Failure to comply with the general safety information may result in extensive property damage, severe personal injury or death.**

Periodic maintenance is essential to the efficient operation and extended service life of this equipment. Failure to provide maintenance as recommended may void the equipment warranty.

### A. Maintenance Schedule

1. Daily
  - a. Check gauges, monitors, instruments and equipment settings.
2. After 8 hours of operation
  - a. Check that fan belts are tight and sheaves are aligned. The fan belts can be checked every 30 days after the first 60 days of new belt run-in. **CAUTION:** Do not overtighten belts.
  - b. Check set screws and bolts on the fan, bearings, couplings, and burner assembly.
  - c. Check gas pressure at regulator.
3. After 48 hours of operation, check bearings for any unusual vibration or excessive temperature.
4. Monthly
  - a. Check all valves, piping and connections for leaks.
  - b. Check the flame signal and safety lockout (RE-02).
  - c. Check the fuel pressure in the fuel supply line to each heater.
  - d. Check the burner manifold pressure at full fire and low fire. At low fire setting, be sure there is a continuous flame along the entire burner length without any blowout spots.
  - e. Clean the flame sensor.
  - f. Inspect filters. Clean or replace as necessary.
  - g. Inspect the main fan bearings, lubricate if necessary. See Section VIII on bearing maintenance.
  - h. Check all dampers, damper actuators and linkages. Adjust and tighten if necessary.
  - i. Ensure that there are no obstruction blocking the air supply to the heater or the air discharge from the heater.
  - j. Inspect the area and make sure that no combustible or hazardous material has been stored within the clearances as shown on the unit nameplate.
  - k. Check and clear all air sensing tubes and fittings. **CAUTION:** Remove tubes from switches, transducers, and flow station before using compressed air to blow through tubing.
  - l. Test ignition spark. There should be a continuous spark for 10 seconds with last gas cock turned off.
5. Quarterly
  - a. Complete the monthly maintenance schedule.
  - b. Inspect all drives for proper belt tension and wear.
  - c. Check the alignment of the sheaves and adjust if necessary.
  - d. Inspect all bearings set screws for tightness and lubricate bearings if necessary.
  - e. Check the flame and spark rod wiring and connections.
  - f. Check the flame and spark rods. Replace if necessary.
  - g. Inspect the burner carefully. Clean and adjust if necessary.
  - h. Check voltages and amp draw on main fan motor.
  - i. Check the operation of all safety controls individually.
  - j. Check the operation of the automatic gas shut off valves and check them for leakage at the pressure test ports provided.
  - k. On vertical units inspect burner clean out and drain if necessary.
6. Off Season or Yearly
  - a. Complete the monthly and quarterly maintenance schedule.
  - b. Inspect all fan wheels and housings. Clean if necessary.
  - c. Check that all fan wheels, sheaves, and couplings are securely set on the shaft.
  - d. Inspect all bearings and alignment. Adjust if necessary.
  - e. Inspect all V-belts, sheaves, and coupling inserts. Replace if necessary.
  - f. Inspect all electrical components, connections and terminals. Clean and tighten where necessary.
  - g. Test ignition spark. Adjust gap if necessary.
  - h. Clean ignition electrodes and check for cracks.
  - i. Test flame safeguard relay and replace components if necessary.
  - j. Inspect all regulators, relief valves, motorized valves, solenoid valves, vent valves, manual shut off valves and safety shut off valves. Check their operation and clean as necessary.
  - k. Ensure all vents to the atmosphere are clean and free from obstruction.
  - l. Inspect and clean all drip legs in the fuel line.
  - m. Lubricate fan motor as directed by motor manufacturer.
  - n. Inspect fan motor wiring for loose connections.
  - o. Lightly oil all door latches.
  - p. Check that cabinet is weathertight, replace door gaskets and recaulk as necessary.
  - q. Check all nuts and bolts for tightness.

**NOTE: Keep screened air intakes clear of obstructions at all times.**

## B. Lubrication Instructions

Item	Manufacturer	Bearing Type
All 3 phase fan motors (1 HP to 100 HP) ODP, TEFC <i>Recommendation: See following note.</i>	US., Baldor or equal	Single row ball bearings
All 1 phase motors (Fractional HP) ODP, TEFC or TEAO <i>Recommendation: See following note.</i>	Century, G.E., or equal	Bronze sleeve bearings
Fractional HP single phase, ODP or TEFC <i>Recommendation: See following note.</i>	Century, G.E. or equal	Bronze sleeve bearings
Fan shaft bearings <i>Recommendation: See following note.</i>	Fafnir or equal	Self-aligning single row or double row ball bearings, resilient mounted
Dampers <i>Recommendation: See following note.</i>	Factory or equal	Sleeve

1. Blower Motors – Some motors require lubrication while others do not. Those that require lubrication can be identified by the presence of grease plugs in the motor casing at each end. Motors that do not have grease plugs cannot be greased and are lubricated for the life of the motor bearing.

Lubrication of motors should be done while the motor is warm and at a standstill. Remove and clean all grease plugs and insert a grease fitting in the upper hole in the motor casing at each end. (Viewed as if motor were sitting horizontally on its base). There may be one or two plugs in each end casing of the motor. Add a small amount of a clean, good grade ball bearing grease, such as Exxon Polyrex EM or equal, with a low pressure grease gun. Run the motor five minutes before removing the grease fittings and replacing the plugs.

**CAUTION: An excess of grease will overheat the bearings.**

**NOTE: On totally enclosed fan cooled (TEFC) motors, the rear end fan housing must be removed to expose the grease plugs.**

2. Pillow Block Bearings – Pillow block bearings are used on supply blower(s). Bearings have been pre-lubricated with a number 2 lithium base grease. Relubrication should be done with a similar grease using a low pressure grease gun. Wipe all grease fittings clean before adding grease. Grease should be added slowly, in small amounts at frequent intervals while the shaft is being manually rotated.

A slight showing of grease at the seals with accompanying normal bearing temperature indicates proper lubrication. Normal temperature can range from “cool” to “hot to the touch” depending on size, speed and surrounding conditions. Excessive bearing temperature indicates faulty lubrication. An insufficient amount of grease is suggested by a bearing showing no grease at the seals, and a higher than normal temperature and noise level. Excessive leakage of grease at the seals, and a high operating temperature suggest too much grease.

Frequency of Lubrication – Frequency of lubrication depends upon operating conditions. The bearing operating temperature is the best index for determining a relubrication schedule. The following chart gives the frequency of relubrication based upon continuous operation for various operating temperatures and can be used as a satisfactory guide for determining when all ball and roller bearings should be relubricated.

Speed	Temperature	Cleanliness	Interval
100 RPM	Up to 125°F	Clean	6 months
500 RPM	Up to 150°F	Clean	2 months
1000 RPM	Up to 210°F	Clean	2 weeks
1500 RPM	Over 150°F	Clean	weekly
Any Speed	Up to 150°F	Dirty	1 week to 1 month
Any Speed	Over 150°F	Dirty	daily to 1 week
Any Speed	Any Temp.	Very Dirty	daily to 1 week
Any Speed	Any Temp.	Extreme Conditions	daily to 1 week

### Browning Bearing Set Screw Torque Values

Model#	Shaft Size	Torque (in-lbs)
<b>Set Screw</b>		
VPS-212	3/4	66 - 85
VPS-214	7/8	66 - 85
VPS-116	1	66 - 85
VF2S-116	1	66 - 85
VPS-219	1 3/16	66 - 85
VF4S-219	1 3/16	66 - 85
VPS-220	1 1/4	126 - 164
VPS-223	1 7/16	126 - 164
VPS-323	1 7/16	126 - 164
VF4S-227	1 11/16	126 - 164
VPS-327	1 11/16	228 - 296
VPS-231	1 15/16	228 - 296
VF4S-231	1 15/16	228 - 296
VPS-331	1 15/16	228 - 296
VPS-235	2 3/16	228 - 296
VF4S-235	2 3/16	228 - 296
VPS-236	2 1/4	228 - 296
VPS-239	2 7/16	228 - 296
VF4S-243	2 11/16	348 - 452
VPS-343	2 11/16	348 - 452
VPS-347	2 15/16	348 - 452
<b>BOA Concentric</b>		
VPB-231	1 15/16	220 - 240
VPB-331	1 15/16	220 - 240
<b>Spherical Roller</b>		
SPB 1000 NE	1 3/16	290 - 380
SPB 1000 NE	1 7/16	290 - 380
SPB 1000 NE	1 11/16	290 - 380
SPB 1000 NE	1 15/16	290 - 380
SPB 1000 NE	2 3/16	290 - 380
SPB 1000 NE	2 7/16	620 - 930
SPB 1000 NE	2 11/16	620 - 930
SPB 1000 NE	2 15/16	620 - 930
<b>Sealmaster SleeveLoc</b>		
SPB 2115 C2	1 15/16	65

**When replacing bearings refer to the manufacturers installation instructions included with the bearing.**

#### Typical Procedure For Changing The Shaft And Bearings

1. Remove protective shaft coating.
2. Remove the drive side sheave.
3. Disconnect the grease lines from the existing bearings.
4. Identify the total shim thickness at each bearing and mark the bearing mount for future reference.
5. Remove mounting bolts for bearings and remove any shims.
6. Loosen bearing and blower wheel shaft setscrews.

7. Remove the shaft from the unit by sliding the bearings and blower wheels along the shaft as the shaft is extracted. Unless a blower wheel is damaged, it should be unnecessary to remove the blower wheel from the blower housing.
8. Slide the new shaft through the first blower wheel hub.
9. Once the shaft is completely through the first blower wheel, slide a bearing onto this end of the shaft.
10. Slide the shaft through the next blower wheel hub and add another bearing. Continue this procedure until the shaft is through all of the blower wheels.
11. Place a bearing on each end of the shaft.
12. Replace the old shims with new.
13. Bolt the bearings in place and reattach the grease lines. (When installing a SleeveLoc bearing see note at bottom of page).
14. Adjust the shaft so the blower hub keyways are in the middle of the shaft keyways.
15. Adjust the shaft so it protrudes past the non-drive end bearing, the blower sheave keyway mates with the shaft keyway, and the drive side sheave can be aligned with the motor sheave. Ideally, the blower sheave should be as close to the drive side bearing as possible, the motor sheave should be as close to the motor housing as possible, and the belts should be straight.
16. Be sure the shaft does not rub on or interfere with the closing of the access door.
17. Align all bearing setscrews, so that the same set screw on each bearing is pointed in the same direction as the other bearings' setscrews.
18. Place a drop of "BLUE" Loctite on the bearing setscrews and tighten all of the setscrews. Follow the mounting instruction's procedure on the inside of the bearing box, for the proper tightening and torque values.
19. Align the blower hubs' keyway with those in the shaft. Be sure the clearance between the blower wheel and blower housing is the same on each side.
20. Rotate the shaft by hand to insure free operation. Correct any rubbing of the blowers on the housings.
21. Place a drop of "BLUE" Loctite on the blower setscrews and tighten all of the setscrews.
22. Align the blower and motor sheaves using a laser or straight edge and tighten the blower sheave to the shaft.
23. Replace the belts and tighten the motor base adjustment for the proper belt tension. Over tightening the belt tension will severely reduce belt and bearing life. Belt deflection should be approximately 1/64 inch of the belt span.

24. Monitor for excessive heat or vibration during operation.
25. All bearings are pre-lubricated and should not require greasing. Refer to the bearing manufacturer's instructions or the unit manufacturer's instructions for proper bearing maintenance.

**Note: Drive side SleeveLock bearing installation (SPB-2115-C2).**

1. **Mount all the bearings and leave all the bolts and setscrews loose**
2. **Tighten setscrews on SleeveLock bearing to the tightening pattern as described in the installation sheet that comes with the bearing to a final 65 inch lbs while rotating the shaft. Check to make sure the insert of the bearing is centered in the bearing housing and then bolt bearing down.**
3. **Tighten down the bolts and setscrews on the remaining bearings per installation sheet starting from the end bearing back toward's the SleeveLock while rotating the shaft.**

3. Dampers – Dampers should be inspected monthly (**daily in icy weather**) for securely fastened linkages, and smooth operation. If dampers are binding or excessively noisy, then lubrication may be required. Place one drop of #20 wt. machine oil, silicone spray, graphite or equal on each blade bearing, and linkage ball joint. Do not over lubricate, and wipe any excess from the area. Be sure to note that dampers over 49 inches long have intermediate bearings which require lubrication.

**C. Air Filters**

All filter banks should be equipped with a manometer or differential pressure switch to indicate when the filters are dirty. Filters should be replaced when the differential pressure across them reaches the manufacturer's recommended final value. Dirty filter elements should be replaced with a clean element of the same type and size. In addition, the factory not only suggests, but insists, that air filters be **checked every 30 days** and replaced with new filters (throw-away type) or cleaned (washable type) as required. Cleanable filters should be given new application of filter coating after washing to maintain optimum filter performance.

The frequency of cleaning and replacing air filters applies twelve months of the year, **where blowers are used for ventilation and heating.**

**D. Belt Tensions and Adjustments**

Belt tension is adjusted during the initial run-in and test periods at the factory. However, the belts are run as slack as possible to prevent excessive damage to the bearings, yet tight enough to prevent slippage.

It is necessary, therefore, to tighten all belts during the first few months of operation, and to **check for proper tension weekly during the first 60 days**, after which 30-day check intervals are sufficient.

**NOTE: Turn off all power to the equipment before checking belt tensions.**

**CAUTION: Do not attempt to tighten any belt or belts by changing the pitch of an adjustable pulley, as this will change the speed of a driven pulley, causing the unit to be rendered OUT OF AIR BALANCE. Do not overtighten belts.**

**Suggested Belt Tension Method**

1. Check tension frequently during the first 24-48 hours of run-in operation. Ideal tension is the lowest tension at which the belt will not slip under peak load conditions. Over tensioning shortens belt and bearing life.
2. To properly tension a conventional V-belt drive use the following procedure:
  - a. Measure the span length.
  - b. At the center of the span, apply a force perpendicular to the span to deflect the belt 1/64 inch for every inch of span length. For example, for a 40 inch span, apply a force that will deflect the belt 40/64 or 5/8 of an inch.
  - c. Compare the force you have applied with the values given in the table below. If the force is between the values for normal tension and 1-1/2 times normal tension, the belt tension should be satisfactory. If the belt tension is not within this range, it can be adjusted by loosening the motor mounting bolts, and adjusting the position of the motor along its base.

**B Section**

small pulley diameter range in Inches	Belt Manufacturer & Type Belt	Pounds Force for Normal Tension	Pounds Force for 1½ times Normal Tension
3.4-4.2	Gates Hi-Power	4.4	6.6
4.4-4.6	Gates Hi-Power	4.9	7.4
5.8-8.6	Gates Hi-Power	5.8	8.7

Note: For recommendation of other types of belts, consult respective manufacturers.

**E. Optional Coils And Related Items**

1. Coils – Coil surfaces must be kept clean of dirt and lint in order to operate at rated efficiency. Coils should be inspected on a regular basis and cleaned as required.

**CAUTION: Solutions used to clean coils must not be corrosive to metals or materials used in the manufacturer of this equipment. If cleaning solutions are applied through means of high pressure spray, care must be taken to avoid damaging the coil fins.**

2. Condensate Drain Pan – Periodically flush the condensate pan and drain system with a water hose.

#### **F. Gaskets**

Gaskets are used on doors, inspection covers, some filter racks, and some outdoor air dampers. Inspect gaskets periodically and repair or replace as required.

#### **G. Caulking**

Inspect cabinet and add caulking as required.

#### **H. Casing**

Periodic cleaning of the casing is recommended to remove dirt, grease and corrosive substances that may injure finish. Rusted or corroded areas should be cleaned and painted.

#### **I. Support**

Inspect the entire support structure to be sure everything is firmly in place.

#### **J. Heater**

1. At least a yearly inspection is recommended for heating installations and more frequently for process applications in year-round operation. Your own experience is the best guide in determining frequency of inspection, but as a minimum the following procedure should be followed:
  - a. Shut the system down totally, disconnecting or locking out power supply so there can be no accidental start-up during inspection.
  - b. Inspect the burner carefully, including upstream and downstream sides of mixing plates as well as burner body face. Note that complete burner assembly may have to be removed for proper inspection and cleaning. Any accumulation of scale or foreign material on either side of the mixing plates should be removed with a wire brush. Check visually that no holes in the mixing plates are blocked. If any burner ports are plugged (even partially) clear them with a piece of wire. See Maintenance of Gas Ports.

If any mixing plates are loose or missing fasteners, tighten/replace as necessary. Always use zinc plated or stainless fasteners. The mixing plates on the burner may display “hairline” cracks.

These cracks are normal, and caused by thermal stresses occurring during combustion.

The presence of these “hairline” cracks in no significant way affects the combustion efficiency or performance of the heater. Should a large opening develop, it may cause difficulties in cross ignition of flame across the face of the burner. If this does occur, the specific mixing plate or plates involved **must** be replaced.

- c. Put system back into operation and view burner while cycling through full firing range. This will give a visual check for blocked burner ports.

2. Inspect the flame rod and ignition electrode for dirt and moisture. Wipe off if necessary. Examine for any evidence of premature arcing. If in doubt, check continuity of flame rod to be sure it is not grounding out. Replace if required.

The porcelain on the ignition electrode must be intact - not cracked. The spark gap should be 1/8 of an inch on Mestek burners.

3. Replace all access panels which have been removed and operate the unit for a test period. Check for normal response and function of all controls.
4. Check all gas piping for possible leaks using a soap bubble solution.
5. Inspect the support means to be sure that everything is firmly anchored in place.

**WARNING: Do not enlarge burner ports or performance may be drastically affected.**



## SECTION IX - MESTEK LINE BURNERS

### Inspection and Maintenance of Gas Ports

Conduct initial inspection within the first month after commissioning. Visually check the gas ports of new burner assemblies for any piping scale or debris. Use Pin Vise with drill bit to remove.

Annual inspections are normally adequate once the initial piping debris is removed. The operating conditions of the burner will determine how frequently maintenance is actually required.

Use of an electric drill motor is not suggested unless both Pin Vise and Drill can be chucked up in a vari-speed drill unit. Use caution, because it is easy to snap the bits off in a port when using a drill motor. Removal of broken bits from the gas ports is difficult.

Alternate drill size which may be used is a 5/64" (for #45).

### P001117 - Mestek Line Burners

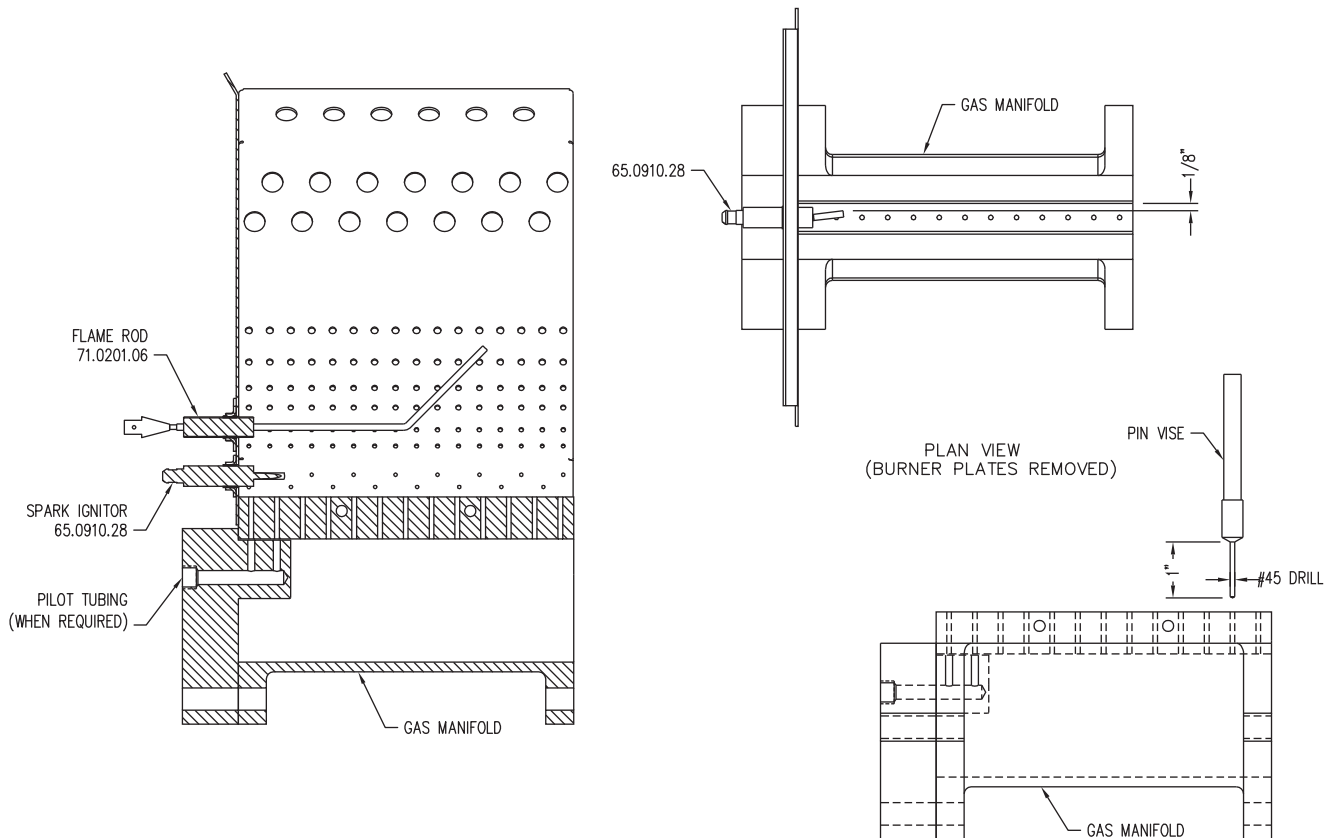



## SECTION X - MANIFOLD AND VALVE ADJUSTMENTS

The I/O Zone 583 Controller (UC-01) must be calling for the burner to be enabled. The DO-2 light will be on and Burner Enable Relay (RE-28) needs to be energized. This will put power to the Burner Relay (RE-02). **If the outside air temperature is above the Heating Economizer 65°F Setpoint the burner will be disabled.** You will need to disconnect the plug where the Outside Air Temperature Sensor (TS-01) and Discharge Air Temperature Sensor (TS-03) are wired to the I/O Zone 583 Controller (UC-01), see High Fire and Low Fire Adjustment in following section. Reconnect the plug if you are getting close to the Freezestat lockout time, approximately 3 minutes. To reset the Freezestat alarm simply turn the power off and back on at the disconnect switch.

**NOTE: A BACview6, Equipment Touch, or PC is required to change settings. See the Digital Control System User Manual for a more detailed sequence of operation.**

Prior to setting high and low fire you should have your test equipment installed and be familiar with the gas valve (VG-07) and its adjustment, see High Fire and Low Fire Adjustment in following section. For High Fire Setpoint refer to rating plate on unit for Normal Manifold Pressure in inches of water column. The typical high fire flame should be blue and approximately 12 to 18 inches long with short orange to yellow tips. After high fire has been set, low fire may need to be re-adjusted. Cycle the burner several times to be sure it lights off reliably. Low fire is a visual setting.

**CAUTION: There should be a continuous flame along the entire burner length without any blow-out spots.**

### HIGH AND LOW FIRE MANIFOLD ADJUSTMENT FOR MAXITROL VALVES WITH DDC

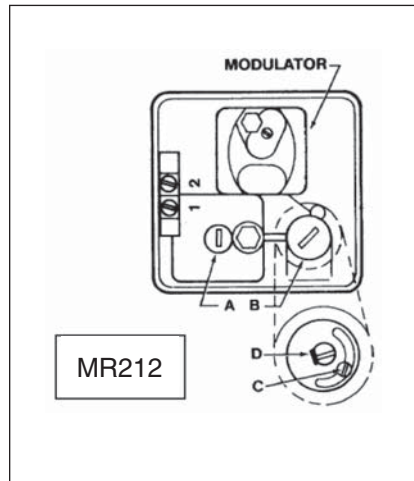

(MR212)

#### High Fire Manifold Adjustments

Note: Low fire may need to be set first to get the burner to light off properly.

1. Disconnect the plug where the Temperature Sensors (TS-01 and TS-03) are wired to the unit control module (UC-01). A minimum of 15vdc is required at terminals #5 and #6 on electric relay (RE-26). This causes the valve to call for continuous high fire. **Caution: The unit will shut down on freezestat after approximately 3 minutes.**
2. Remove seal cap (A) and turn regulator pressure adjusting screw to obtain normal manifold pressure (clockwise rotation increases pressure).

#### Low Fire or Bypass Adjustments

1. Disconnect wire from (RE-26) terminal #8. This causes valve to call for continuous low fire.
2. Remove cap (B) and loosen lock screw (C). Turn (D) to desired low fire adjustment. (Clockwise rotation reduces minimum flow rate.)
3. Tighten screw (C), replace cap (B), and reconnect wire to (RE-26) terminal #8.
4. Reconnect the plug back into the jack on the unit control module (UC-01).

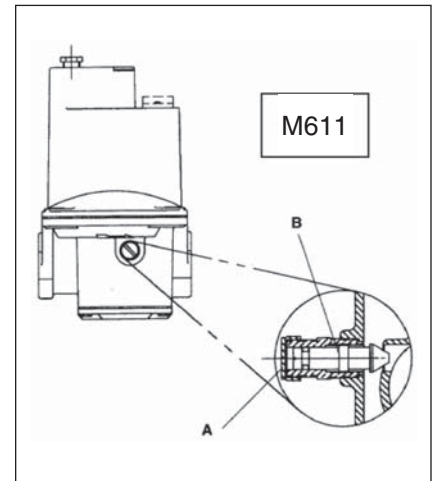

(M611)

#### High Fire Manifold Adjustments

Note: Low fire may need to be set first to get the burner to light off properly.

1. Disconnect the plug where the Temperature Sensors (TS-01 and TS-03) are wired to the unit control module (UC-01). A minimum of 15vdc is required at terminals #5 and #6 on electric relay (RE-26). This causes the valve to call for continuous high fire. **Caution: The unit will shutdown on freezestat after approximately 3 minutes.**
2. Adjust the gas pressure regulator (GP-05) to obtain the normal manifold pressure.

#### Low Fire or Bypass Adjustments

1. Disconnect wire from (RE-26) terminal #8. This causes valve to call for continuous low fire.
2. Remove cap (A) and turn adjusting screw (B) to desired low fire adjustment. (Clockwise rotation reduces minimum flow rate.)
3. Replace cap (A) and reconnect wire to (RE-26) terminal #8.
4. Reconnect the plug back into the jack on the unit control module (UC-01).

## CIRCUIT ANALYSIS – MAXITROL GAS VALVES

Connect a DC volt meter (capable of reading 0-24V DC) on the Modulator (M611) or Modulator-Regulator (MR212) Valve terminals.

The operation of the Valve with regard to voltage is as follows: from 0 volts to approximately 5 volts, the modulating valve should be on bypass flow with the heater operating on low or minimum fire. From approximately 5 volts to 15 volts DC, the valve should be performing its modulating function, and the heater should be firing at a modulated flow rate between low and high fire, depending upon the voltage. Above approximately 15 volts DC, the Valve should be delivering full flow to the heater and the unit should be on full fire. If the DC voltage is obtained on the Valve terminals, but the heater does not respond as described, the problem can be isolated to the valve itself or to the gas control manifold of the heater.

If the proper voltages are not obtained the problem can be isolated to the electronics and/or electronic relay (RE-26). See the Trouble Shooting Section and the Digital Control System User Manual.

See the Thermistor Output Curve in the following section.

## SECTION XI - THERMISTOR OUTPUT CURVE

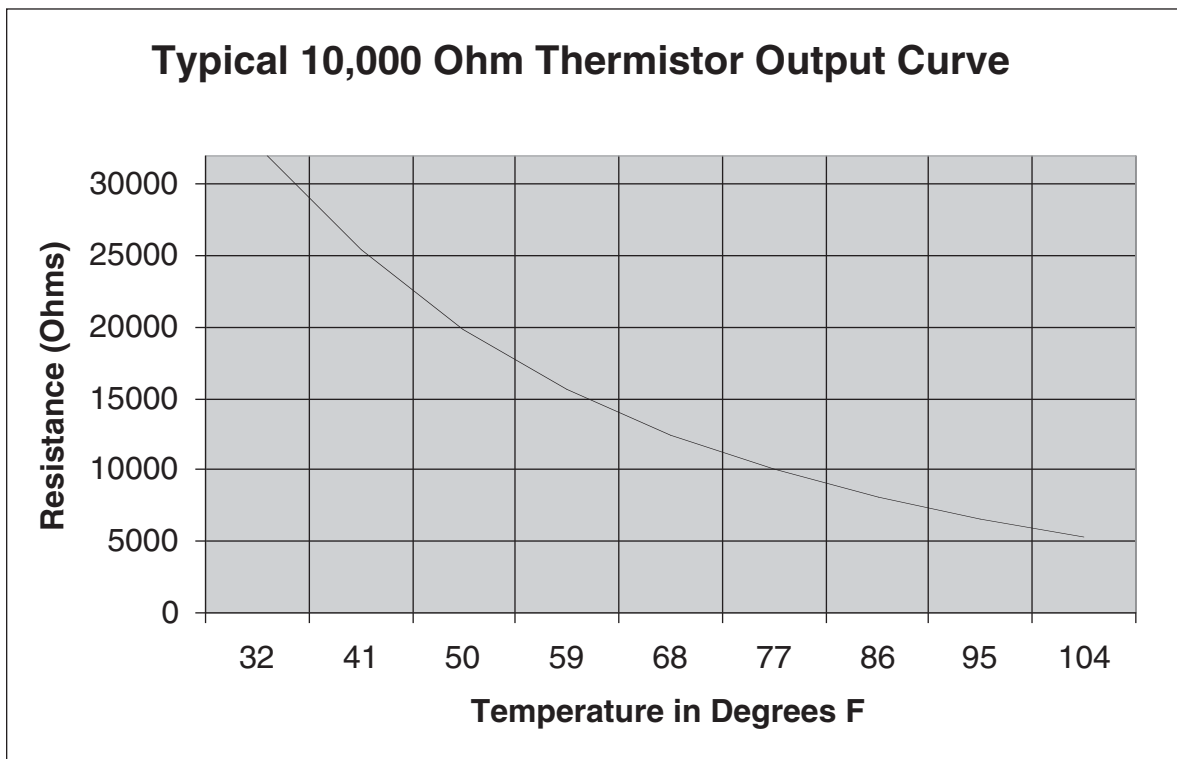

## SECTION XII - REPLACEMENT PARTS

Replacement parts may be ordered from the factory. All warranty parts will be shipped freight allowed from factory for normal ground service. Warranty parts must be returned prepaid within **30 days**. Credit will be issued if part is complete, defective and returned on time.

When parts are ordered, MODEL NUMBER, SERIAL NUMBER, FACTORY ORDER (F.O.) and PART NUMBERS are required. Belts, filters, and fuses are not covered under warranty.

Dealer/Contractor Name: \_\_\_\_\_

Address: \_\_\_\_\_

City: \_\_\_\_\_

State: \_\_\_\_\_ Zip: \_\_\_\_\_ Ph: \_\_\_\_\_

## SECTION XIII - RECIRCULATION

**WARNING: On Heaters, which recirculate room air, outside ventilation air must be provided in accordance with the information shown on the heater nameplate.**

Recirculation of room air may be hazardous in the presence of:

- flammable solids, liquids and gases
- explosive materials such as grain dust, coal dust, gunpowder, etc.
- substances such as refrigerants or aerosols which may become toxic when exposed to heat or flame

Recirculation is not recommended in uninsulated buildings where outside temperatures fall below 32°F (0°C).

Excessive recirculation or insufficient ventilation air, which results in inadequate dilution of combustion products generated by the heater, may create hazardous concentration of carbon monoxide, nitrogen dioxide, and other combustion products in the heated space.

If gas fork trucks or other fossil fuel powered equipment are utilized in the conditioned area, additional ventilation requirements for the facility must be addressed separately.

The heater inlet shall be located in accordance with applicable building code provisions for ventilation air.

Field constructed intake accessories should be properly designed to minimize the entry of snow and rain.

All ventilation air to the heater shall be ducted directly from the outdoors.

If in doubt regarding the application, consult the heater manufacturer.

ETL labeled heaters must be equipped with a control system and an air measuring station provided by the heater manufacturer and installed on the return air damper or duct.



# Applied Air

4830 Transport Drive, Dallas, TX 75247

Phone: 214-638-6010

[www.appliedair.com](http://www.appliedair.com)