

# Energy Recovery Module

Technical Guide for:

- **ERM** Total Energy Recovery Module



Applied Air

Keeps You

# Comfortable



Applied Air

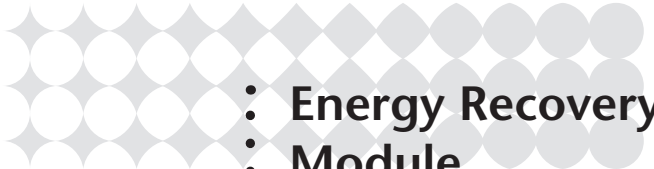

**: Energy Recovery  
: Module  
: Technical Guide**



**Applied Air**

In the business of 100% Outside Air solutions, efficient and low-cost operation is essential. Applied Air keeps you comfortable for less.

Since 1975, Applied Air has been providing cost-effective, reliable outside air solutions. Our proven 100% Outside Air Systems add conditioned clean air to your space. The optional Indirect Fired Heating section provides tempered air without the products of combustion in the airstream.

This Technical Guide will help you choose an Applied Air Energy Recovery System to provide efficient, cost-effective cooling, heating and ventilation for your facility. The Guide covers:

- Technical Specifications — Configure the right system components (e.g., motors, drive, options, etc.) to meet your needs.
- Installation Information — Plan details of on-site installation (dimensions, wiring, etc.).

If you have questions, please contact Applied Air's Customer Service Department at 214-638-6010. We'll be glad to help.

**Applied Air**

**Keeps You**

**Comfortable**



# Applied Air

<b>Principle of Operation</b> .....	4
<b>Features</b> .....	5
<b>ARI Certification</b> .....	6
<b>Unit Selection Procedure</b> .....	7
<b>HVAC System Capacity Reduction</b> .....	8
<b>Technical Data</b> .....	9
<b>ARI Certified Ratings</b> .....	9
<b>Air Delivery Table – ERM-40 Exhaust Section</b> .....	10
<b>Dimensions</b> .....	11
<b>Unit Weights</b> .....	11
<b>Typical Wiring</b> .....	12
<b>Amp Draw Table</b> .....	13
<b>Guide Specifications</b> .....	14

# General

## Principle of Operation

Applied Air's ERM Series is an energy recovery unit. It is provided as a add on module that can be used with either split systems or packaged rooftop DOAS systems.

ERM modules include a rotary heat exchanger that provides sensible and latent energy exchange between the entering and exhaust air streams of a building. This allows a substantial amount of the energy that is normally lost in the exhaust air stream to be returned to the entering air.

In the heating mode, the wheel rotates to provide a constant transfer of heat from the warmer exhaust airstream to the colder intake air stream. During the cooling season, the process is reversed and water vapor is also removed from the outside air and released into the exhaust air stream.

The ERM heat exchanger contains parallel layers of a polymeric material impregnated with silica gel, a desiccant. The wheel is located in the entering (intake) air and exhaust air streams of the ventilation equipment. As the wheel rotates through each air stream, the wheel surface captures sensible and latent energy.

Ideal applications are those with high occupancy loads or high ventilation requirements. Geographical locations with cold winter and hot summer temperatures offer great opportunities for energy recovery. High humid climates also offer excellent opportunities for summertime energy recovery.

With ARI-certified sensible and latent efficiencies in the 60 to 70% range, the energy savings can be substantial.

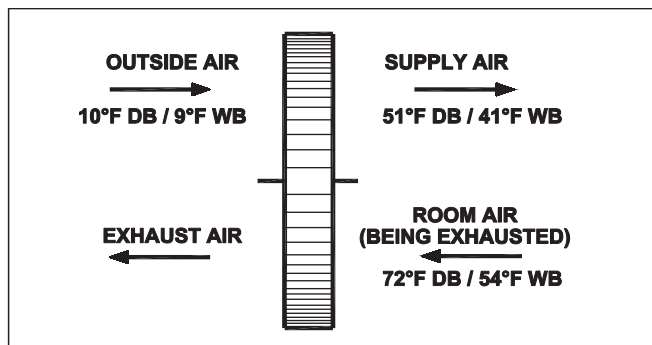

TYPICAL PERFORMANCE- WINTER

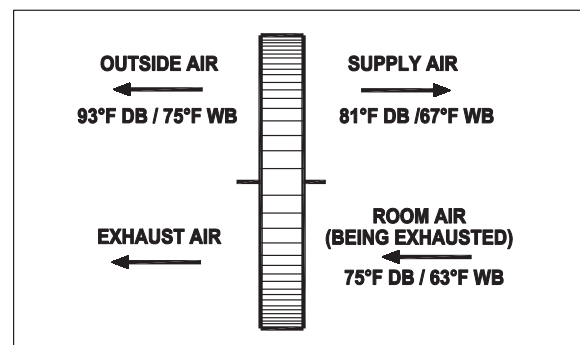

TYPICAL PERFORMANCE- SUMMER

# Features

## Features

### Low Maintenance

- Removable side panels enable easy access to the enthalpy wheel, blower(s), motor and drive components.
- The wheel cassette slides out easily for inspection and maintenance.
- Wheel sections are easily removed, without tools, for periodic cleaning.
- Filters are easily accessible.
- No need for condensate drains, as moisture is transferred entirely in the vapor phase.
- Light weight polymer wheel contributes to low shaft and bearing loads, resulting in reliable, long-life operation.

### No Condensation

- During both summer and winter operation, the ERM wheel transfers moisture entirely in the vapor phase. This eliminates wet surfaces that retain dust and promote fungal growth. It also eliminates the need for a condensation pan and drain to carry water away.

### Self Cleaning

- Because it is constantly rotating, the wheel is always being cleaned by the counter-flowing air streams. Since the wheel is always dry, dust and other particles impinging on the surface during one half cycle are automatically removed during the next half cycle. This cleaning process occurs with every wheel revolution.

### Fully Tested Blower Assemblies

- Exhaust blowers are housed within a sheet metal frame to ensure reliable performance.
- Exhaust blower motor is mounted on an adjustable motor mount that provides an easy method of adjusting belt tension.
- Exhaust blower(s) are equipped with adjustable motor sheave pulley.
- The blower pulley and the motor pulley are aligned by a high precision laser alignment system.

### Filtration

- Module is supplied with an aluminum mist eliminator filters for the intake air.
- Exhaust air is filtered with nominal two inch thick pleated filters.

### Fully Tested Control System

- Control system is fully wired.
- Control system is independently fused.
- Furnished with color-coded wires.

### ARI-Certified Energy Recovery Wheel

- The performance of the enthalpy wheel is certified by ARI to Standard 1060 to provide the assurance of proper energy savings.
- For further details on the parameters that are certified by ARI, see the following section.

# Features

## ARI Certification

Selecting an ARI-certified product offers one the assurance that the chosen product will perform as indicated in the ARI directory. The energy recovery wheel utilized in ERM module is ARI-certified to Standard 1060 for the following parameters:

- Airflow
- Air Pressure drop
- Sensible Effectiveness at 100% and 75% of rated airflow for heating and cooling
- Latent Effectiveness at 100% and 75% of rated airflow for heating and cooling
- Total Effectiveness at 100% and 75% of rated airflow for heating and cooling
- Exhaust Air Transfer at +1.0, 0.0 and -1.0 inches w.c. pressure differential between the two airstreams
- Outdoor Air Correction Factor at +1.0, 0.0 and -1.0 inches w.c. pressure differential between the two airstreams

With reference to the schematic shown below, these parameters can be defined as:

**Effectiveness** – The measured energy recovery effectiveness (whether sensible, latent, or total) unadjusted to account for that portion of the psychrometric change in the leaving supply air (“2”) that is the result of leakage of entering exhaust air (“3”) rather than the exchange of heat or moisture between air streams.

**Net Effectiveness** – The measured energy recovery effectiveness (whether sensible, latent, or total) adjusted to account for that portion of the psychrometric change in the leaving supply air (“2”) that is the result of leakage of entering exhaust air (“3”) rather than the exchange of heat or moisture between air streams.

**Exhaust Air Transfer Ratio, EATR** – The tracer gas concentration difference between the leaving supply air (“2”) and entering (outdoor) air stream (“1”), divided by the tracer gas concentration in the entering exhaust (return) air stream (“3”) at 100% rated airflow, expressed as a percentage.

**Outdoor Air Correction Factor, OACF** – The entering supply (outdoor) airflow (“1”) divided by the measured (gross) leaving supply airflow (“2”).

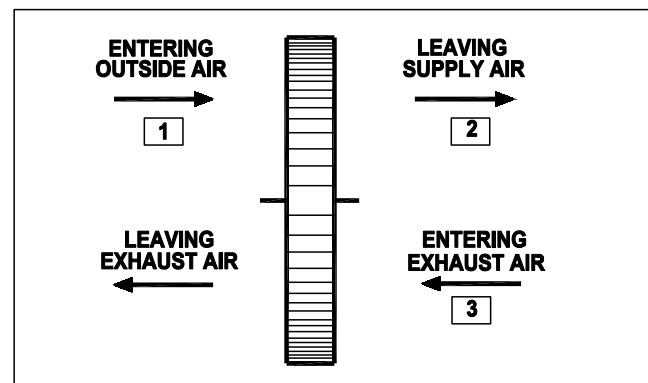

FORMULA LOCATIONS

# Unit Selection

## Selection Procedure and Example

### Selection Procedure

#### Given:

- Outdoor airflow rate at standard conditions of 70 degrees F at sea level.
- Exhaust airflow rate at standard conditions of 70 degrees F at sea level.
- Outdoor air dry bulb temperature, DB, in degrees F and wet bulb temperature, WB, in degrees F at the winter and summer design conditions.
- Indoor air dry bulb temperature, DB, in degrees F and wet bulb temperature, WB, in degrees F at the winter and summer design conditions.

#### Procedure:

1. Select ERM Model size from Performance Table on page 9.
2. Determine Sensible Effectiveness (SE) and Latent Total Effectiveness (LTE) at the given airflows using ARI Certified Ratings tables on page 9.

#### Summer Operation:

3. Calculate the supply air Dry Bulb (DB) temperature leaving the energy recovery wheel at the summer design conditions:  
$$DB_{SL} = DB_{OA} - ((DB_{OA} - DB_{RA}) * SE)$$

Where:  
DB<sub>SL</sub> = Lvg Supply Air DB Temperature  
DB<sub>OA</sub> = Outside Air DB Temperature  
DB<sub>RA</sub> = Return Air DB Temperature  
SE = Sensible Effectiveness
4. Using a psychrometric chart or electronic psychrometric calculator, find the humidity ratio corresponding to the given dry bulb and wet bulb temperatures for the entering supply and exhaust airflows.
5. Calculate the supply humidity ratio leaving the energy recovery wheel at the summer design conditions:

$$W_{SL} = W_{OA} - ((W_{OA} - W_{RA}) * LTE)$$

#### Where:

- W<sub>SL</sub> = Lvg Supply Air Humidity Ratio  
W<sub>OA</sub> = Outside Air Humidity Ratio  
W<sub>RA</sub> = Return Air Humidity Ratio  
LTE = Latent Total Effectiveness

6. Using a psychrometric chart or electronic psychrometric calculator, find the leaving wet bulb temperature for the supply airflow corresponding to the dry bulb temperature calculated in Step 3 and humidity ratio calculated in Step 5.

#### Winter Operation:

- Repeat steps 3 through 6 (A low temperature psychrometric chart is generally required).
7. Using the given supply airflow and the given static pressure drop across energy wheel, find the supply air blower HP required in the Air Delivery Tables in Air Handler Tech Guide. Using the given exhaust airflow and the given external static pressure, find the exhaust air blower HP required in the Air Delivery Tables on page 10.

### EXAMPLE:

#### Given:

- Outdoor airflow rate = 6,600 CFM.
- Exhaust airflow rate = 6,600 CFM.
- Summer Operation:  
Outdoor air = 99 DB/ 75 WB  
Indoor air = 75 DB/ 63 WB
- Winter Operation:  
Outdoor air = 13 DB/ 12 WB  
Indoor air = 72 DB/ 54 WB

#### Procedure:

1. From ERM Performance Table on page 9, select model with wheel size 5874 C.
2. From ARI Certified Ratings on page 9:  
SE = 68% and LTE = 63%.
3. Summer Operation:  
$$DB_{SL} = 99 - ((99 - 75) * 0.68) = 82.7^{\circ}F$$
4. At 99/75, W<sub>OA</sub> = 0.0141; at 75/63, W<sub>RA</sub> = 0.0096
5. 
$$W_{SL} = 0.0141 - ((0.0141 - 0.0096) * 0.63)$$
  
W<sub>SL</sub> = 0.0113
6. WB<sub>SL</sub> = 67.9

#### Note:

As an alternative to the manual calculation procedure described above, contact factory for computer print out from application software. The software also shows annual energy savings calculations and system capacity saved for both heating and cooling applications.

## HVAC System Capacity Reduction

A significant benefit of enthalpy energy recovery is the ability to use it to reduce the size and cost of the chiller and boiler in a central system and that of the cooling load in a DX packaged unit. While it is optional to take advantage of the benefits in the

central system, it is mandatory in the DX system to achieve proper control of humidity. If this is not done, the system becomes over-sized and could result in excessive moisture and occupant discomfort.

The following example shows the power of enthalpy in reducing the size of the heating and cooling loads.

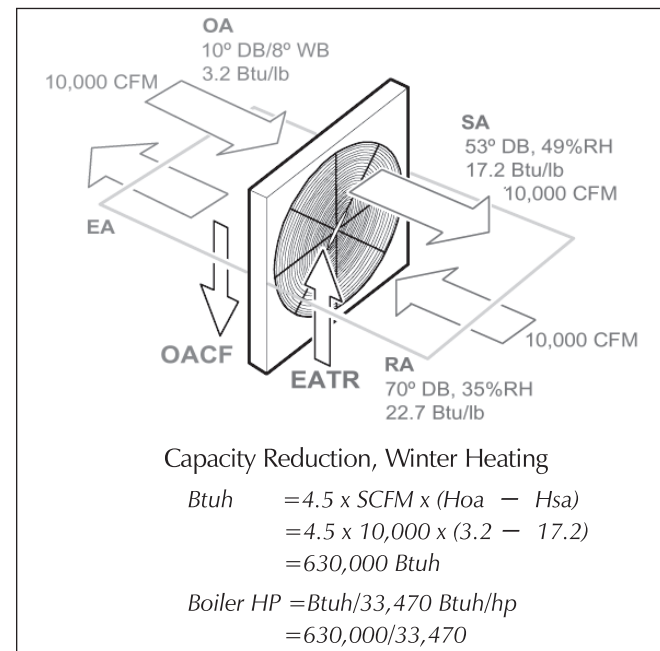
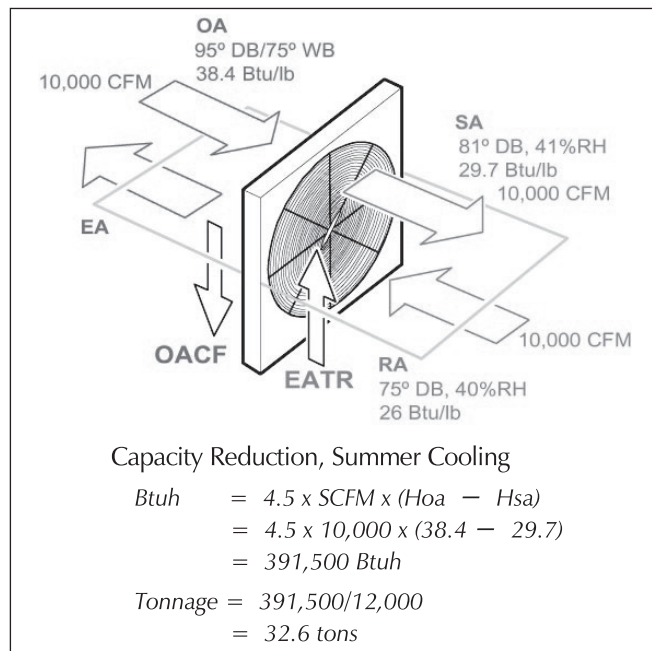



# Performance

## Technical Data

		1,500 - 5,000 CFM	5,001 - 9,500 CFM
Exhaust Air Blower	Wheel Diameter x Wheel Width (Inches)	10 X 10	10 X 10
	Qty of Blowers	One	Two
	Motor Speed (RPM)	1,725	1,725
	Motor Sheave	Adjustable	Adjustable
	Bearing Type	Ball	Ball
	Motor Service Factor	1.15	1.15
Wheel Electrical Data	Motor HP	1/4	1/4
	Voltages Available	200-230/460	200-230/460
Wheel Data	Wheel Depth (Inches)	3	3
	Construction / Media Type	Segmented Pies / Polymeric	Segmented Pies / Polymeric

## ARI Certified Ratings

Thermal Ratings at 0.00 inches w.c. Pressure Differential

Parameter	Operating Condition	5856 C Energy Wheel			5874 C Energy Wheel		
		Sensible	Latent	Total	Sensible	Latent	Total
Total Effectiveness	100% Airflow Heating	75%	69%	73%	68%	60%	65%
	75% Airflow Heating	79%	74%	77%	73%	67%	71%
	100% Airflow Cooling	75%	69%	71%	68%	60%	63%
	75% Airflow Cooling	79%	74%	76%	73%	67%	70%
Net Effectiveness	100% Airflow Heating	75%	69%	73%	68%	60%	65%
	100% Airflow Cooling	75%	69%	71%	68%	60%	63%
Enthalpy Wheel ARI Rating Data							
		5856 C Energy Wheel			5874 C Energy Wheel		
Nominal Airflow (CFM)		5,600 @ 1.00" w.c. delta P			6,600 @ 0.95" w.c. delta P		
Parameter	Operating Condition						
EATR	delta P = -1.00" w.c.	5.00%			4.60%		
	delta P = 0.00" w.c.	2.40%			1.90%		
	delta P = +1.00" w.c.	1.30%			0.90%		
OACF	delta P = -1.00" w.c.	1.00%			0.99%		
	delta P = 0.00" w.c.	1.05%			1.05%		
	delta P = +1.00" w.c.	1.09%			1.09%		

# Performance

## Air Delivery Table - ERM-40 Exhaust Section

SCFM	Energy Wheel		Total Static Pressure							
	Size	$\Delta P$	0.50	0.75	1.00	1.25	1.50	1.75	2.00	
1500	5856C	0.27"	1/2	1/2	3/4	-	-	-	-	
2000		0.35"	3/4	3/4	3/4	1	1	1-1/2	-	
2500		0.43"	1	1	1-1/2	1-1/2	1-1/2	1-1/2	2	
3000		0.51"	1-1/2	1-1/2	2	2	2	2	3	
3500		0.59"	-	2	3	3	3	3	3	
4000		0.67"	-	3	3	3	5	5	5	
4500		0.75"	-	5	5	5	5	5	5	
5000		0.83"	-	-	5	7-1/2	7-1/2	7-1/2	7-1/2	
5500		5874C	0.60"	-	3	3	3	5	5	5
6000			0.65"	-	3	3	5	5	5	5
6500	0.70"		-	5	5	5	5	5	5	
7000	0.75"		-	5	5	5	5	7-1/2	7-1/2	
7500	0.80"		-	-	5	7-1/2	7-1/2	7-1/2	7-1/2	
8000	0.86"		-	-	7-1/2	7-1/2	7-1/2	7-1/2	7-1/2	
8500	0.91"		-	-	7-1/2	7-1/2	7-1/2	10	10	
9000	0.96"		-	-	7-1/2	10	10	10	10	
9500	1.01"		-	-	10	10	10	10	-	

**NOTES:**

1. Add Energy Wheel  $\Delta P$  for supply CFM to Total Static Pressure calculations for air handler.
2. Add Energy Wheel  $\Delta P$  for exhaust CFM to exhaust ductwork static pressure losses to obtain Total Static Pressure for exhaust section.
3. Drive losses are included in above data.

# Dimensional Data & Unit Weight

C000700

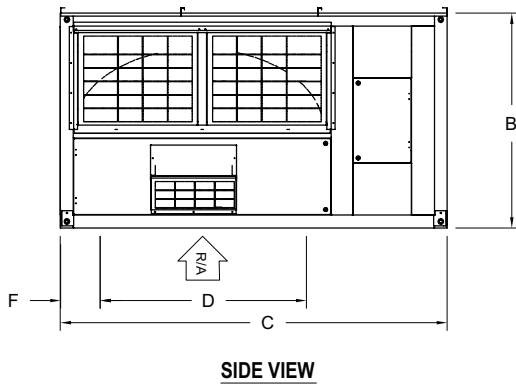
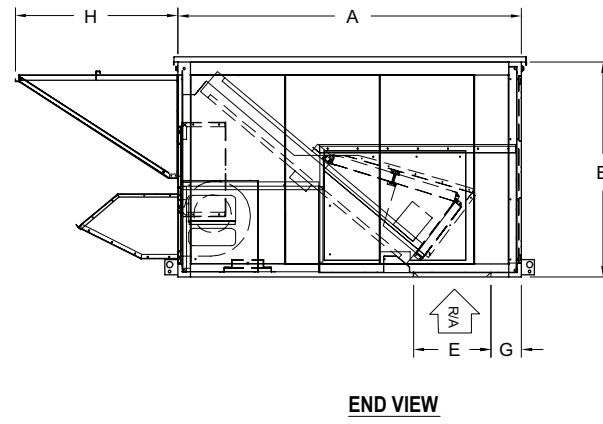
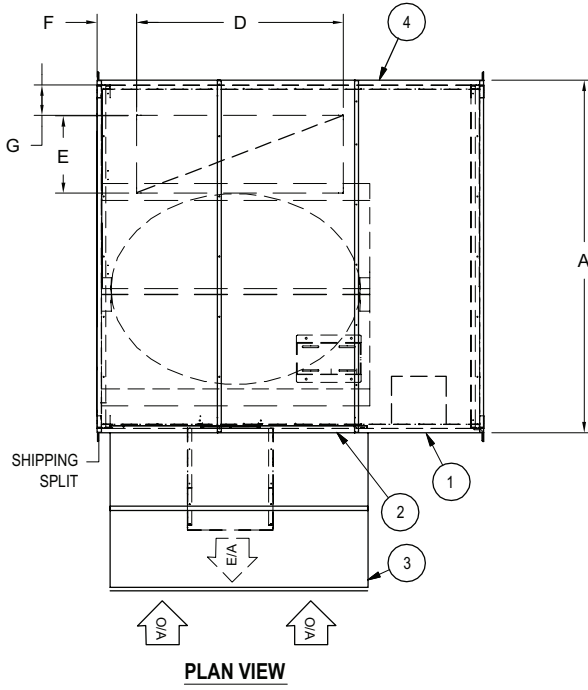

### EQUIPMENT DESCRIPTION

1. ENERGY RECOVERY MODULE (ERV) SECTION CONTROL ENCLOSURE.
2. POWERED RETURN AIR BLOWER MOTOR ACCESS THIS SIDE.
3. INLET AIR HOOD SHIPPED LOOSE FOR FIELD MOUNTING BY OTHERS, WITH (2) 27.5 X 40 CLEANABLE FILTERS.
4. HINGED ACCESS DOOR TO R/A FLAT BANK FILTER RACK, WITH 30% PLEATED FILTERS, (9) 15 x 20 x 2.

Cabinet Size	CFM Range	Shipping Weight (lbs)	Dimensions							
			A	B	C	D	E	F	G	H
40	1500 to 5000	1435	82	50	90	48	18	9-1/4	7-1/8	38
	5001 to 9500	1500								

# Typical Wiring

C000701

CAUTION: OPEN & LOCK  
OUT MAIN DISCONNECT  
SWITCH BEFORE  
SERVICING EQUIPMENT

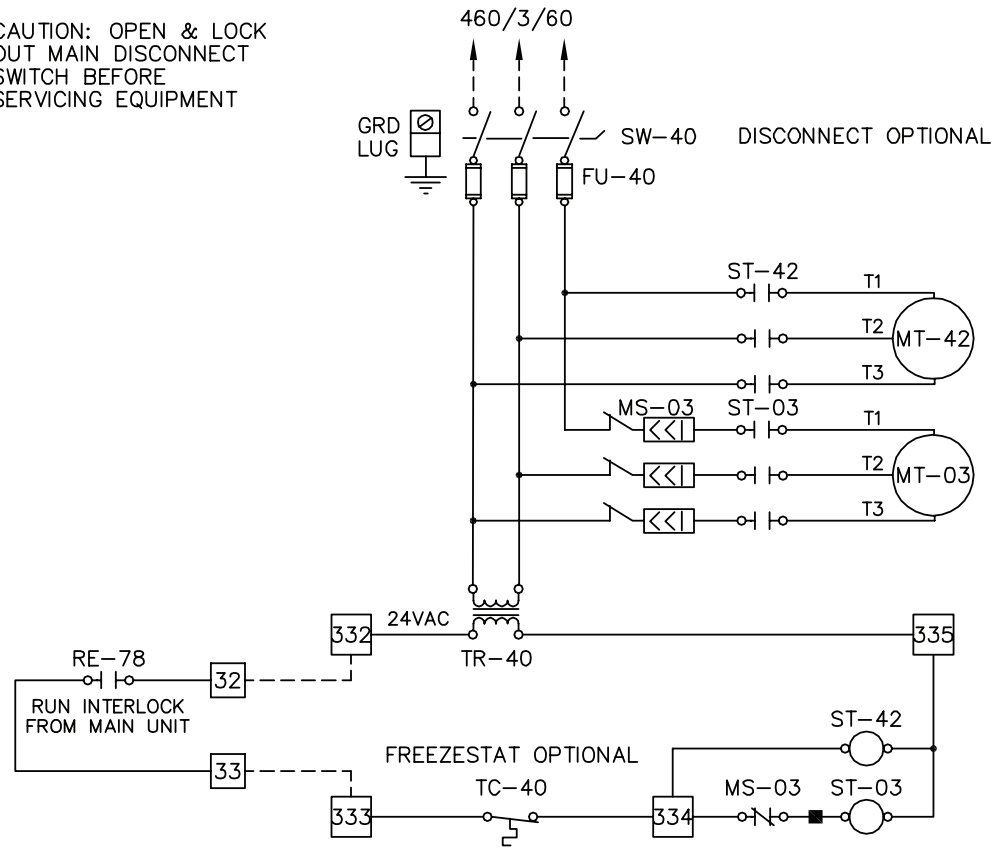

## COMPONENT IDENTIFICATION

- FU-40 MAIN ERV MODULE FUSE
- MS-03 MANUAL MOTOR PROTECTOR, EXHAUST FAN
- MT-03 MOTOR, EXHAUST FAN
- MT-42 MOTOR, DESICCANT WHEEL
  
- RE-78 EXHAUST INTERLOCK RELAY (IN MAIN UNIT)
- ST-03 MOTOR STARTER, EXHAUST FAN
- ST-42 MOTOR CONTACTOR, DESICCANT WHEEL
- SW-40 SERVICE DISCONNECT, ERV MODULE
- TC-40 THERMOSTAT, LOW AMBIENT

## NOTES

- 1) UNIT SHALL BE GROUNDED ACCORDING TO THE LATEST PROVISIONS OF NEC.
  - 2) FOR SEQUENCE OF OPERATION PLEASE SEE USER MANUAL.
  - 3) BECAUSE OF SHIPPING RESTRICTIONS FIELD CONNECTIONS AND/OR WIRING BETWEEN COMPONENTS OR SECTIONS MAY BE REQUIRED
- ⊗ DENOTES WIRE NUT
  - DENOTES JUMPER WIRE
  - ┬— DENOTES WIRE CONNECTION
  - DENOTES CONTROL CABINET TERMINAL BLOCK & WIRE NUMBER  
1 TO 99 - 115 VOLT  
101 TO 399 - 24 VOLT
  - DENOTES WIRING BY OTHERS
  - △ DENOTES COMPONENTS BY OTHERS

# Amp Draw Table

## Item A

SOURCE	AMPS @	MOTOR HORSEPOWER				
		1/2	3/4	1	1-1/2	2
Blower Motor	208V, 3 Ph.	2.4	3.5	4.6	6.6	7.5
	230V, 3 Ph.	2.2	3.2	4.2	6.0	6.8
	460V, 3 Ph.	1.1	1.6	2.1	3.0	3.4
	575V, 3 Ph.	0.9	1.3	1.7	2.4	2.7
SOURCE	AMPS @	MOTOR HORSEPOWER				
		3	5	7-1/2	10	
Blower Motor	208V, 3 Ph.	10.6	16.7	24.2	30.8	
	230V, 3 Ph.	9.6	15.2	22.0	28.0	
	460V, 3 Ph.	4.8	7.6	11.0	14.0	
	575V, 3 Ph.	3.9	6.1	9.0	11.0	

## Item B

SOURCE	AMPS @	CONTROL TRANSFORMER
Control Transformer	208V, 3 Ph.	1.0
	230V, 3 Ph.	1.0
	460V, 3 Ph.	1.0
	575V, 3 Ph.	1.0

## Item C

SOURCE	AMPS @	ENERGY WHEEL DRIVE MOTOR
Control Transformer	208V, 3 Ph.	2.3
	230V, 3 Ph.	2.5
	460V, 3 Ph.	1.2
	575V, 3 Ph.	0.95

Steps to determine total amp draw for heat wheel section:

1. Find exhaust blower motor HP required from Air Delivery Table for exhaust section.
2. Find amp draw for required motor HP in Item A above.
3. Find amp draw for control transformer in Item B above.
4. Find amp draw for required Energy Wheel drive motor in Item C above.
5. Add up amps from step 2, step 3, and step 4.

# ERM Guide Specifications

## Applied Air

Base Bid Applied Air Model ERM \_\_\_\_\_ Energy Recovery Module designed for rooftop outdoor applications. The unit shall be factory fabricated, assembled, wired, and tested prior to shipment in accordance with the specification and equipment schedule. The unit will include all components herein and as shown on the drawings and as indicated on the equipment schedule. Alternate equipment, equal in design, construction, performance and capacity to units(s) specified, must be shown with price deduct/add, if any. Approval of alternate equipment shall be subject to review of shop drawings. The unit shall be capable of delivering \_\_\_\_\_ °F DB/\_\_\_\_\_ °F WB leaving air conditions with \_\_\_\_\_ supply SCFM and \_\_\_\_\_ exhaust SCFM at \_\_\_\_\_ ESP using a \_\_\_\_\_ horsepower (ODP) (TEFC) motor operating on (208) (230) (460)/3/60.

### CASING

The unit shall be constructed from a formed supporting frame and panel type casing of 18 gauge galvanized steel, suitably reinforced to withstand 6" of TSP. All panels shall be factory sealed with caulking between mating panels.

The complete unit shall be weatherproof with up turned and caulked seams on the roof and floor. Factory fabricated roof cap(s) shall be shipped loose for field mounting over standing roof seam(s). All electrical components shall be housed within the unit casing, separate add on enclosures are not acceptable.

The unit shall have an integral heavy gauge formed sheet metal base complete with curb adaptor frame for mounting on a full perimeter roof curb.

The unit will incorporate heavy gauge internal gussets at top and specially designed lifting lugs at base to pull sections together.

Access doors shall be supplied to allow physical entry to all sections requiring inspections and periodic maintenance. Access doors shall have lift off hinges, 1" thick insulation, interior metal liner, captive screws, fasteners, and handles.

### EXHAUST BLOWER SECTION

Each unit shall be supplied with centrifugal forward curved, DWDI fan(s) rated in accordance with AMCA standards. The fan or fans shall be mounted on a heavy duty, turned and ground and polished solid steel shaft designed for a maximum operating speed not to exceed 75% of its first critical speed. The fan bearings are heavy-duty pillow block, self-aligning and pre-lubricated with a minimum L10 bearing life of 40,000 hours.

Drives shall have a capacity 25% greater than the motor horsepower. The motor sheave shall be of the adjustable pitch type.

The fan motor shall be mounted on an adjustable base and wired in flexible conduit to the control panel at the factory.

### ENERGY WHEEL

The energy recovery component shall incorporate a rotary wheel in an insulated cassette frame complete with seals, drive motor, and drive belt.

The total energy recovery wheel shall be coated with silica gel desiccant permanently bonded by a patented and proprietary process without the use of binders or adhesives, which may degrade desiccant performance. The substrate shall be lightweight polymer and shall not degrade nor require additional coatings for application in marine or costal environments. Coated segments shall be washable with detergent or alkaline coil cleaner and water. Desiccant shall not dissolve nor deliquesce in the presence of water or high humidity.

## ERM Guide Specifications

The wheel shall be wound continuously with one flat and one structured layer in an ideal parallel plate geometry providing laminar flow and minimum pressure drop-to-efficiency ratios. The layers shall be effectively captured in stainless steel wheel frames or aluminum and stainless steel segment frames that provide a rigid and self-supporting matrix. Wheel shall be provided with removable energy transfer matrix. Wheel frame construction shall be a welded hub, spoke and rim assembly of stainless, plated and/or coated steel and shall be self-supporting without matrix segments in place. Segments shall be removable without the use of tools to facilitate maintenance and cleaning. Wheel bearings shall be selected to provide an L-10 life in excess of 400,000 hours. Rim shall be continuous rolled stainless steel and the wheel shall be connected to the shaft by means of taper locks.

All diameter and perimeter seals shall be provided as part of the cassette assembly and shall be factory set. Drive belts of stretch urethane shall be provided for wheel rim drive without the need for external tensioners or adjustment.

The energy recovery cassette shall be an Underwriters Laboratories Recognized Component for electrical and fire safety. The wheel drive motor shall be an Underwriters Laboratories Recognized Component and shall be mounted in the cassette frame and supplied with a service connector or junction box. Thermal performance shall be certified by the manufacturer in accordance with ASHRAE Standard 84, Method of Testing Air-to-Air Heat Exchangers and ARI Standard 1060, Rating Air-to-Air Energy Recovery Ventilation Equipment. Cassettes shall be listed in the ARI Certified Products Directory and bear the ARI Certified Product Seal.

### ELECTRICAL CONTROLS

The Energy Recovery Module electrical control enclosure shall be complete with hinged access door. All control components are to be labeled and individually wired to a numbered terminal strip to aid in servicing. All wiring shall be color coded and number tagged at each end to match the control diagram supplied. Full set of drawings, operating and maintenance instructions shall accompany each unit. All wiring between the controls shall be run in flexible conduit. All electrical components shall bear the U.L. label.

### OPTIONAL EQUIPMENT & CONTROLS

1. Disconnect switch
2. Freezestat
3. Perimeter (12") (18") high roof curb.
4. Painted galvanized casing



Applied Air



Efficient  
Fresh Air  
Comfort  
Systems

**Choose Applied Air Systems**

- Heat large spaces or warehouses without products of combustion in the supply air
- Mount units indoor, outdoors, or on the roof
- Low operating and maintenance costs
- Simple, inexpensive installation
- Applied Air, a leader in research, engineering, and customer service since 1975

Applied Air

[www.appliedair.com](http://www.appliedair.com)

4830 Transport Drive Dallas TX 75247

Telephone 214.638.6010

Fax 214.905.0806

 A MESTEK COMPANY