



# Applied Air

## INSTALLATION, OPERATION AND MAINTENANCE MANUAL FOR DFC & DFM DIRECT GAS-FIRED HEATERS WITH DDC CONTROLS

**ATTENTION: READ THIS MANUAL AND ALL LABELS ATTACHED TO THE UNIT CAREFULLY BEFORE ATTEMPTING TO INSTALL, OPERATE OR SERVICE THESE UNITS! CHECK UNIT DATA PLATE FOR TYPE OF GAS AND ELECTRICAL SPECIFICATIONS AND MAKE CERTAIN THAT THESE AGREE WITH THOSE AT POINT OF INSTALLATION. RETAIN FOR FUTURE REFERENCE.**

### FOR YOUR SAFETY

The use and storage of gasoline or other flammable vapors and liquids in open containers in the vicinity of this appliance is hazardous.

### POUR VOTRE SÉCURITÉ

L'utilisation et l'entreposage d'essence ou d'autres liquides ou produits émettant des vapeurs inflammables dans des récipients ouverts à proximité de cet appareil est dangereux.



### FOR YOUR SAFETY

If you smell gas:

1. Open Windows
2. Don't touch electrical switches.
3. Extinguish any open flame.
4. Immediately call your gas supplier.



### POUR VOTRE SÉCURITÉ

Si vous sentez une odeur de gaz :

1. Ouvrez les fenêtres.
2. Ne pas actionner d'interrupteur.
3. Éteindre toute flamme ouverte.
4. Appelez immédiatement votre fournisseur de gaz.

**WARNING: Improper installation, adjustment, alteration, service or maintenance can cause property damage, injury or death. Read the installation, operating and maintenance instructions thoroughly before installing or servicing this equipment.**

**AVERTISSEMENT : Une installation déficiente, de même qu'un mauvais réglage, modification, entretien ou maintenance peuvent occasionner des dommages matériels, corporels voire causer la mort. Lire attentivement les instructions d'installation, d'utilisation et d'entretien avant d'installer ou d'intervenir sur cet appareil.**

### WARNING

Install, operate and maintain unit in accordance with manufacturer's instructions to avoid exposure to fuel substances or substances from incomplete combustion which can cause death or serious illness. The state of California has determined that these substances may cause cancer, birth defects, or other reproductive harm.

### INSTALLER'S RESPONSIBILITY

**Installer Please Note:** This equipment has been test fired and inspected. It has been shipped free from defects from our factory. However, during shipment and installation, problems such as loose wires, leaks or loose fasteners may occur. **It is the installer's responsibility to inspect and correct any problems that may be found.**



**Applied Air**

4830 Transport Drive, Dallas, TX 75247 Phone: 214-638-6010 Fax: 214-905-0806  
www.appliedair.com

## SECTION I - FOREWARD

As is the case with any fine piece of equipment, care must be taken to provide the proper attention to the operation and maintenance details of this machine.

This manual of instructions along with the Digital Control System user manual has been prepared in order for you to become well-acquainted with those details, and in doing so, you will be able to give your Direct Gas-Fired System the care and attention which any piece of equipment needs and deserves.

**It is the customer and installation personnel responsibility to determine if the unit is equipped with all of the safety devices required for the particular application. Safety considerations include the accessibility of the unit to non-service personnel, the provision of electrical lockout switches, maintenance procedures and automatic control sequences. Clearly mark all emergency shutoff devices.**

### Table of Contents

Section I: Foreword, Table of Contents, and Important Notice .....	2
Section II: General Information .....	3
Section III: Installation.....	4
Section IV: Pre-Start Up .....	10
Section V: Unit Start Up.....	12
Section VI: Unit Shut Down.....	14
Section VII: Troubleshooting Guide.....	15
Section VIII: Maintenance Schedule and Lubrication Requirements.....	34
Section IX: Mestek Burner.....	39
Section X: Manifold and Valve Adjustments.....	40
Section XI: Thermistor Curves.....	41
Section XII: Replacement Parts.....	42
Section XIII: Recirculating Units .....	42

### \*IMPORTANCE NOTICE\*

Applied Air assumes no responsibility for loss or damage in transit; therefore, you should protect yourself by following these instructions:

#### Bill Of Lading

Save your bill of lading. It is a contract, and you will need it, provided you have to file a loss or damage claim. Remember, claims are outlawed after nine months.

#### Loss In Transit

Before you sign for this shipment, check against the bill of lading, also the transportation company's delivery ticket. Make sure that you get the exact total of articles listed. Should the delivery ticket show more or less items than are offered, then the carrier's agent must mark the difference on your freight bill before you sign.

#### Visible Damage In Transit

If anything is damaged, accept the shipment only if the carrier's agent places a notation on your freight bill explaining the nature and extent of damage. Upon inspection of article, make claim to the delivering carrier.

#### Concealed Damage In Transit

Sometimes transit damage is not noticed until the goods are unpacked. In such cases, notification to the carrier must be made within fifteen (15) days of receipt of shipment. In such cases, save the packages and packing material, then notify the transportation company at once, and request an inspection. When the inspector calls, have him make out and leave a "concealed" bad order report. He is obliged to give one to you. Insist on it.

#### Disposition Of Damaged Articles

Never return damaged articles to us. They are the property of the transportation company when the claim is filed. They will give you disposition instructions.

#### Packing

We comply with the packing requirements of the transportation companies, and your bill of lading proved that everything was in good condition when shipped. That bill of lading contract requires them to deliver in perfect condition.

## SECTION II - GENERAL INFORMATION

### A. Purpose

The purpose of this manual is to present a guide for proper installation, maintenance, and operation of the Direct Gas-Fired System, and supplement, **but not to replace**, the services of qualified field service personnel to supervise the initial start-up and adjustment of the unit. Persons without previous experience with large commercial and industrial heating equipment should not attempt the initial adjustment and checkout procedure which is essential before such installations may be considered ready for operation. This manual should be made readily available to all operating personnel as an aid in troubleshooting and proper maintenance. Due to the custom nature of this equipment, not all possibilities are addressed in this manual. The customer or installer can obtain information from the local sales representative or by contacting the factory directly.

**WARNING: Failure to comply with general safety information may result in extensive property damage, severe personal injury or death.**

### B. Shipping

Base Direct Gas-Fired units are shipped completely assembled where shipping limitations allow. Optional inlet hoods, filter and/or damper sections, or other large accessories are assembled and shipped mounted and wired whenever possible within limitations of shipping and handling. Any optional accessories shipped separately are shipped as assembled sections. Any wired accessories which have been disassembled for separate shipment require no additional conduit or wire for field reassembly. All wire leads will be tagged for ease of reconnection in the field.

**If the unit and/or accessories cannot be installed immediately, they should be stored in a clean dry environment. If this is not possible and the unit must be stored outdoors, it should be protected from the weather with tarpaulins or plastic coverings. Do not assume that simply covering a**

**unit will keep insects, dust and condensation out of the unit and critical components. Rotate the fan(s) monthly. Prior to beginning installation of a unit that has been in storage for weeks or months, the unit and its components should be closely inspected.**

Shipments are made F.O.B. Dallas, Texas by flat-bed truck. The unit is securely strapped, tied, and blocked to prevent shipping damage. All shipments are checked by an inspector before they are accepted by the carrier. Parts that are shipped unmounted are noted on the bill of lading. These parts, where feasible, are packaged and shipped with the units. Upon receipt of shipment, all units should be checked against the bill of lading to insure all items have been received. All equipment (and any optional accessories) should be checked carefully for physical damage in the presence of the carrier's representative. If parts are missing or damage has occurred, a claim should be filed immediately with the carrier.

All Direct Gas-Fired units are given a complete operations test and control circuit checkout before shipment. Copies of the wiring diagram, piping diagram and bill of material are included with each unit shipped. If correspondence with the factory is necessary, please provide the unit model and serial number.

### C. Optional Factory Service

Periodic service on any piece of mechanical equipment is necessary for efficient operation. A nationwide service support network is available to provide quick and dependable servicing of make-up air, heating, ventilating, or air handling types of equipment. Factory start-up service is also available which includes the presence of a service engineer to supervise the initial start-up and adjustment of the equipment and provide instructions for the owner's maintenance personnel in proper operations and maintenance. Consult factory for quotations on start-up or periodic service.

## SECTION III - INSTALLATION

### FOR CANADIAN INSTALLATIONS ONLY

1. All installations must conform with local building codes, or, in the absence of local codes, with current CAN/CGA-B149-Installation Codes For Gas Burning Appliances and Equipment.
2. All electrical connections must be in accordance with Canadian Electrical Code, Part 1, CSA Standard C22.1.

All electrical connections must conform to the current edition of ANSI/NFPA No. 70 National Electrical Code and applicable local codes; in Canada, to the Canadian Electrical Code, Part 1 CSA Standard C22.1. The following recommendations are not intended to supplant any requirement of federal, state, or local codes having jurisdiction. Authorities having jurisdiction should be consulted before installations are made. Local codes may require additional safety controls and/or interlocks.

All installations in airplane hangers must be in accordance with current ANSI/NFPA No. 409. All installations in public garages must be in accordance with current NFPA No. 88A and NFPA No. 88B.

**CAUTION: Do not install heating system in corrosive or flammable atmospheres! Premature failure of, or severe damage to the unit will result!**

**CAUTION: Heating system must not be installed in locations where air for combustion would contain chlorinated, halogenated or acidic vapors. If located in such an environment, premature failure of the unit will occur!**

### A. Handling the Equipment

As explained previously, the basic unit is designed for shipping in one piece where shipping limitations allow. Some optional accessories may require field mounting.

The Direct Gas-Fired unit has been designed for rigging and handling through the use of special lifting lugs installed on the top and/or sides of each unit. When unloading and setting the unit, use the lifting lugs provided as shown in Drawing #C000539A or move the equipment on rollers. Hooks, jacks, or chains must not be used around the casing, main control panel or exterior mounted controls.

During transit, unloading and setting of the unit, bolts and nuts may have become loosened, particularly in the pillow block ball bearing assemblies in the fan section. It is recommended that all nuts and set screws be tightened. Turn fan shaft by hand to make certain that

blower does not rub against blower housing, and that bearing set screws are tight. If units are not set immediately, cover all openings that might be exposed to the weather.

Open the cover on the electrical control box located on the unit. Inspect all wire terminals and wiring terminations to ensure that all connections are tight.

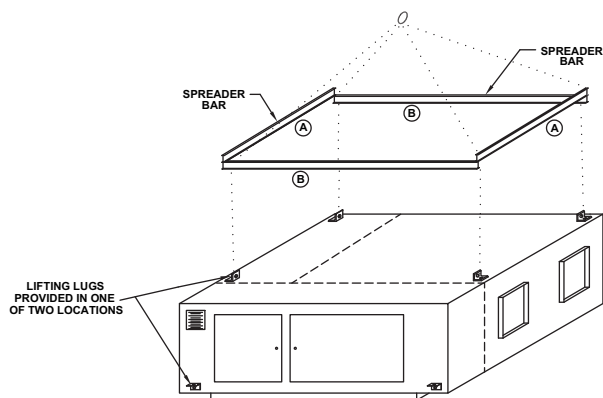
Rotate fans monthly.

**IMPORTANT: Lift and install the modules or sections of a unit separately. Flange connections provided between modules or sections are not structural and damage will occur if any attempt is made to lift modules that have been flanged together.**

**See the specification sheet and submittal drawing for unit or section weight and to determine proper orientation for each section.**

**When unloading sections and/or units or moving equipment to its final location, exercise care to avoid distortion. Lift sections and/or units only by the lifting lugs provided and follow the procedures as outlined below.**

### RIGGING AND MOUNTING DATA - DIRECT FIRED UNITS



A - USE WHEN LIFTING OVER 3,000 LBS.  
B - USE WHEN LIFTING UNDER 3,000 LBS.

08/16/07 C000539A

**WARNING: To insure that a proper unit lift is made, lift unit approximately 24 inches and verify proper center of gravity lift point. To avoid dropping of unit, reposition lifting point if unit is not level. Failure to properly lift unit could result in death or serious injury or possible equipment or property-only damage.**

## B. Locating the Unit

Prior to locating the unit, authorities having jurisdiction should be consulted before installations are made. Approval permits should be checked against the unit received.

On Direct Gas-Fired units, which recirculate room air, outside ventilation air must be provided in accordance with the information shown on the heater nameplate. All ventilation air to the heater must be ducted directly from the outside. See Section XIII.

If in doubt regarding the application of this appliance, consult the factory.

Locate the unit exactly level. Special attention should be given to the duct, electrical, and fuel connection points. Install duct work with adequate flexible connections to isolate vibration from the duct work. All duct work should have taped or caulked seams. Duct work should be properly sized so as not to inhibit airflow. This information should be cross-checked with the position of support beams and stand pipes to insure that clearance dimensions coincide with those of the unit. The minimum clearance to combustible material must be maintained as listed in Table 1.

**Table 1**

Minimum clearance to combustible material, also consult local codes and regulations.

<b>Clearances to Combustible Material</b>		
	<b>Vertical Units</b>	<b>Horizontal Units</b>
Front*	39 inches	39 inches
Rear	6 inches	6 inches
Right	6 inches	6 inches
Left	6 inches	6 inches
Top	12 inches	12 inches
Floor	Zero	6 inches

\*Consider control side as front of unit.

\*\*Optimum clearance for shaft removal would be equivalent to cabinet width.

Make a visual inspection to insure no damage has occurred to the unit during installation.

## C. Curb Mounted Units

Outdoor units can be supplied with an optional roof curb. The curb greatly facilitates installation thereby reducing installation costs. All connections to the unit: duct, piping, electrical power and control wiring can be made through the roof opening. The curb may be shipped prior to unit shipment. All curbs are shipped un-assembled from the factory.

Use extreme caution in handling the curb. Proper handling and positioning will assure a water-tight curb unit installation.

Re-check approval prints prior to installation. Be sure that there are no obstructions to ducting and that proper planning has been exercised in connection of piping and/or electrical services.

The curb assembly may be bolted or welded to either trusses or roof decking; however, connection to roof trusses is recommended. The curb is designed to carry the weight of the unit. Additional support is required for certain applications.

Placement of the curb is critical in squareness and leveling. Shims for leveling must be applied to the curb; application of shims to the unit will tend to destroy the sealing effect after installation. Make sure sealing tape is in place before unit is set. Be careful not to allow gaps where two pieces of sealing tape meet. A bubble level must be used in the leveling process. Measure across diagonals to check for squareness. Allowable tolerance is 1/4" difference between diagonal measurements. Double-check approval prints before setting the unit.

Upon completion of setting the curb, apply roofing material and flashing as required.

## D. Location of Accessories

Where applicable, standard or optional accessories will be placed inside the fan section of the unit for shipment, and must be removed and installed by the mechanical or electrical contractor. The inlet hood(s) must be mounted with a field supplied support. Remotely located discharge or inlet dampers must be equipped with an end switch and interlocked to insure maximum design opening before starting and running circuits may be energized.

Field constructed intake accessories should be properly designed to minimize the entry of rain and snow.

Adequate building relief must be provided, so as to not over-pressurize the building, when the heater is operating at its rated capacity. This can be accomplished by taking into account, through standard engineering methods, the structure's designed infiltration rate, by providing properly sized relief openings, by interlocking a powered exhaust system, or by a combination of these methods.

## E. Electrical Connections

**WARNING: Open all disconnect switches and secure in that position before wiring unit. Failure to do so may result in personal injury or death from electrical shock.**

**WARNING: Controls must be protected from water. Do not allow water to drip on the ignition system.**

**NOTE: Before installing any wiring, check the unit rating plate for supply power rating.**

All electrical connections must conform to the current edition of: ANSI/NFPA No. 70 National Electrical Code and applicable state and local codes; in Canada, to the Canadian Electrical Code, Part 1 CSA Standard C22.1 and applicable provincial and local codes.

Since shipment of unit may require disassembly after factory check and test, reconnection of some electrical devices will be required in the field. Connect electrical wires (supplied in factory furnished conduit) to appropriate terminals. All leads are tagged to facilitate field connections. See wiring diagram provided with equipment. Complete all wiring to any optional accessories as shown on unit bill of material and electrical wiring diagram as required before applying voltage to the unit.

If damper actuators require field wiring, make sure the gasket and cover are securely mounted and assembly is watertight.

Entry location for all field-installed and control wiring is through the control panel.

If optional disconnect is not furnished with heater, the field provided disconnect must be of the proper size and voltage. Refer to unit rating plate for minimum circuit ampacity and voltage. The disconnect must be installed in accordance with Article 430 of the current edition of ANSI/NFPA No. 70 National Electrical Code.

Check the supply voltage before energizing the unit. The maximum voltage variation should not exceed  $\pm 10\%$ . Phase voltage unbalance must not exceed 2%.

**NOTE: Should any original wire supplied with the heater have to be replaced, it must be replaced with wiring material having a temperature rating of at least 105° C.**

**REMARQUE : Dans le cas où un quelconque des câbles livrés avec l'unité devait être remplacé, il doit être remplacé avec des câbles prévus pour résister à une chaleur d'au moins 105° C.**

## F. Field Piping

### Gas Piping

All gas piping must be in accordance with the requirements outlined in the National Fuel Gas Code - ANSI Z223.1. It is required that a ground union be installed adjacent to the manifold for easy servicing. A drip leg and/or filter should be provided upstream of the unit's inlet gas connection. An additional shut-off must be located external of the unit's enclosure. The location of this valve must comply with all local codes. A 1/8 inch N.P.T. plugged tapping, accessible for test gauge connection, must be installed immediately upstream of the gas supply connection to the unit.

**WARNING: To avoid equipment damage or possible personal injury, disconnect gas piping to this unit until a supply line pressure/leak test has been completed. Connecting the unit before completing the pressure/leak test may damage the unit gas valve and result in a fire hazard.**

**DANGER: Never use an open flame to detect gas leaks. Explosive conditions may exist which would result in personal injury or death.**

On vertical units there is a factory installed "Burner Cleanout" pipe located on the opposite end of the gas piping compartment. This is a clean out to drain any condensate that may have collected in the line burner.

**WARNING: DO NOT connect supply gas to this pipe.**

The gas line should be supported so that no strain is placed on the unit. Pipe compounds which are not soluble to liquid petroleum gases should be used on threaded joints.

Refer to the heater's rating plate to determine the minimum gas supply pressure required to achieve maximum gas capacity for the heater.

Une tuyauterie adéquatement dimensionnée doit être posée jusqu'à l'unité. Veuillez noter que la pression de la tuyauterie d'alimentation en gaz doit correspondre à celle spécifiée sur la plaque d'identification, lorsque l'unité fonctionne à plein rendement.

Refer to the heater's rating plate to determine the maximum supply pressure to the heater.

The appliance and its individual shutoff valve must be disconnected from the gas supply piping system during any pressure testing of that system at test pressures in excess of 1/2 PSIG.

The appliance must be isolated from the gas supply piping system by closing its individual manual shutoff valve during any pressure testing of the gas supply piping system at test pressure equal to or less than 1/2 PSIG.

Correctly sized piping must be run to the unit.

### Regulator Venting

**NOTE:** Regulators and devices that have vent limiting orifices installed do not require a vent line.

- a.) Keep the vent line length as short as possible to minimize the restriction and reduce the vent's tendency to cause regulator pulsation .
- b.) Never use pipe sizes smaller than the vent size; smaller pipe sizes restrict the gas flow. If a long gas vent line length must be used, you should increase the pipe one nominal size for every ten feet of run to keep the flow restriction as low as possible.
- c.) Support the vent line to eliminate strain on the regulator diaphragm case.
- d.) Always point outdoor vent lines in the downward position to reduce the possibility of rain, snow, sleet, and other moisture entering the pipe. Install a bug screen in the end on the vent line.
- e.) Do not locate the vent line terminus near windows, fans, or other ventilation equipment.
- f.) Adhere to all applicable codes and regulations.
- g.) If your vent line causes regulator pulsation, consult your local sales representative or the factory.
- h.) We strongly recommend running a separate vent line for each regulator. Headers with various installed devices can cause regulator malfunction.

**CAUTION:** Ensure the vent line is away from ANY potential ignition sources. It is the installer's responsibility to ensure the vent line is exhausting to a safe environment.

**Please note that gas line pressure must be as shown on specification plate when unit is operating at full input. The high-pressure regulator and relief valve should be, if possible, mounted at least 5 to 10 feet upstream from the appliance regulator on the unit (if possible).**

#### ***Building Pressure Transducer Piping (PT-13)***

Pipe the high side to location inside the building that will not be affected by air movement. Pipe the low side to the atmosphere, positioned so it will not be affected by the wind and not exposed to the elements. Be sure that all tubing is clean and clear of any debris before installing tubes on the transducer.

#### ***Flow Station Transducer Piping (PT-15)***

Pipe the high side to the upstream connection and low side to the downstream connection of the Airflow Station as shown in Drawing # C000643 below. Be sure that all tubing is clean and clear of any debris before installing tubes on the transducer.

### Refrigerant Piping

#### Evaporator Coil – Blow Through

The cooling coil section is located in the unit so that the supply air is blown through the evaporative coil(s). A properly piped trap should be installed to control the condensate flow from the unit and also eliminate conditioned air from being blown out the condensate drain. **See Drawing #C000659B.**

Since the condensate is drained by gravity, avoid long runs of drain piping. If a long run of piping cannot be avoided or the piping has water flow restrictions, such as several elbows; add extra height to provide enough hydrostatic head to overcome the frictional losses. Always slope piping down a minimum of 1/8" per foot in the direction of the flow.

On initial start-up, it may be necessary to fill the trap manually or allow the unit to operate only long enough for a small amount of condensate to collect in the drain pan. Then turn off the unit and the trap will automatically fill.

#### **G. Field Wiring and Remote Control Installation**

1. Connect the power lines to the line side of the main disconnect switch.
2. Mount and wire remote control panel, thermostats, temperature sensors, and any other field installed controls as indicated on the unit control wiring diagram.
3. Connect the wires to the appropriate field wiring terminals as indicated on the unit control wiring diagram.
4. Field wiring shall have a temperature rating of at least 105°C. The minimum size of the supply cable circuit shall be sufficient for the maximum ampacity of the heater.

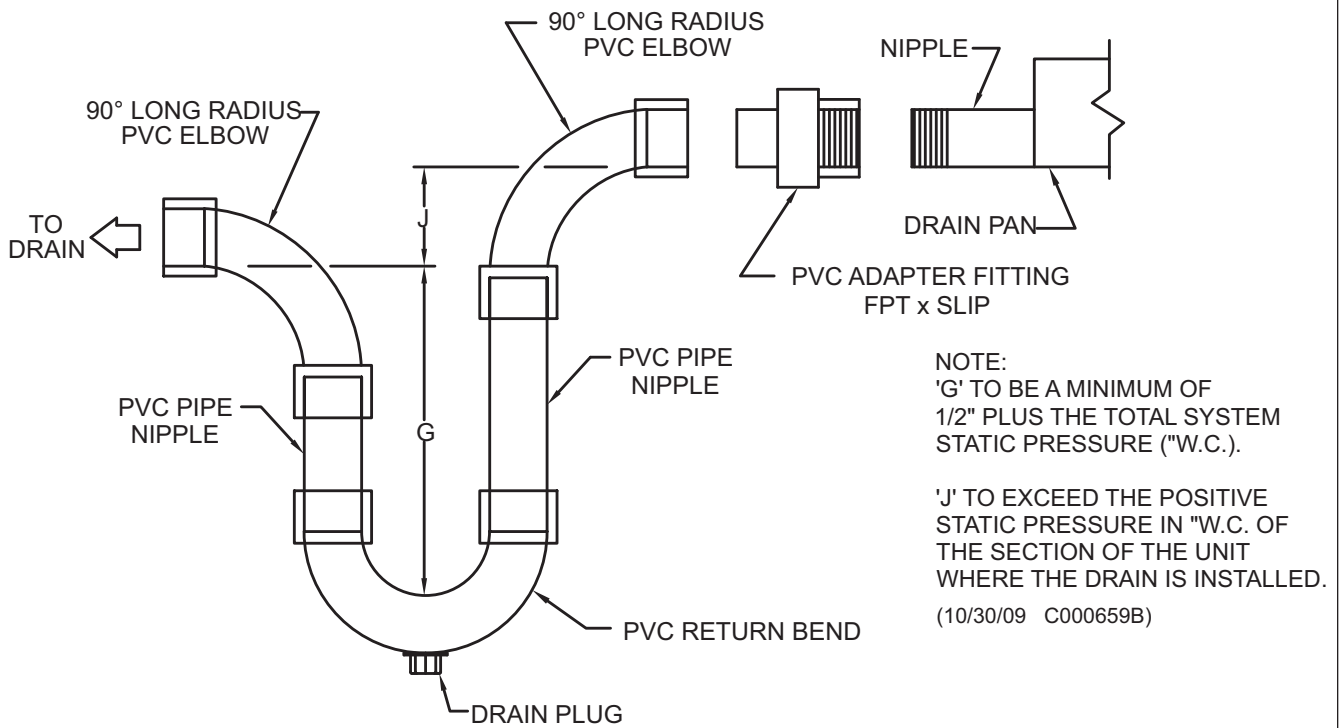
L'installation électrique d'utilisateur aura une température qui évalue d'au moins 105°C. La minimum de source du circuit de câblage sera suffisante pour le ampacity maximum de l'appareil de chauffage.

#### **H. Locating Temperature Controls**

The room or outdoor sensors should be mounted where they will not be subjected to direct impact of the heated air or radiant heat from the sun. It is also recommended that thermostats, especially those with mercury bulb contacts, be mounted on a vibration free surface. The side of building columns away from the heater or interior walls are usually the location best suited for mounting thermostats.

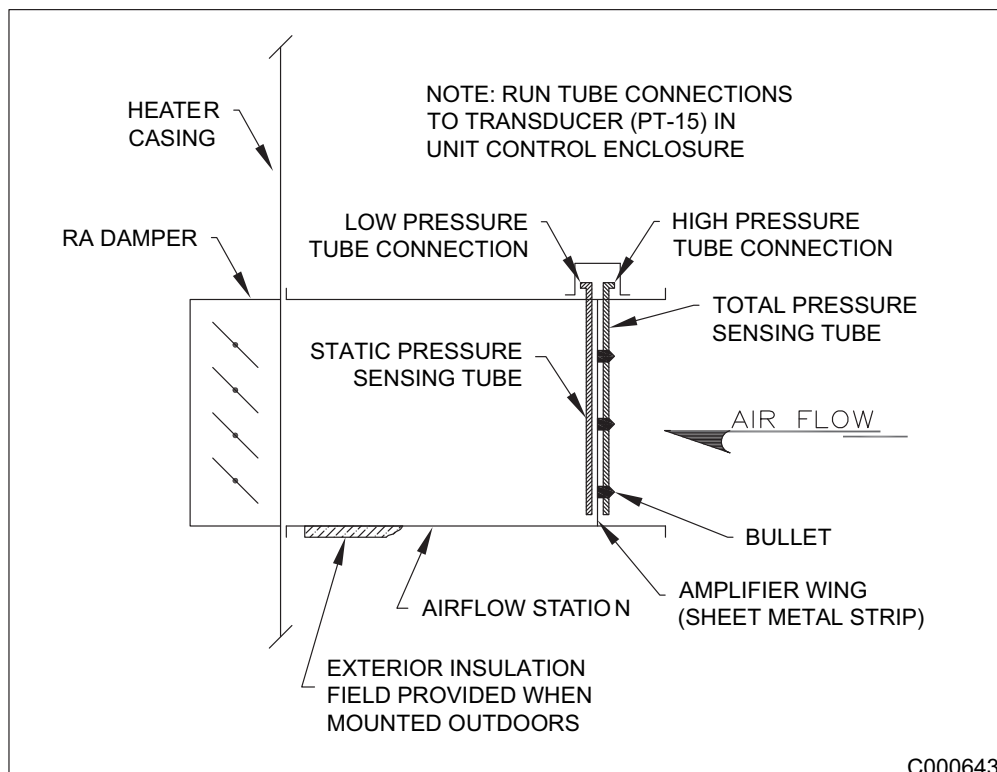
Controls with outdoor sensors require that the outdoor sensor be shielded from direct radiation from the sun. Unit mounted sensors are factory located and mounted.

**SUGGESTED P-TRAP DESIGN FOR CONDENSATE  
DRAIN PANS UNDER A POSITIVE PRESSURE**



10/30/09 C000659B

**AIRFLOW STATION LAYOUT**



C000643

## DIRECTIONS FOR FIELD ASSEMBLING AND WEATHERPROOFING SECTIONS

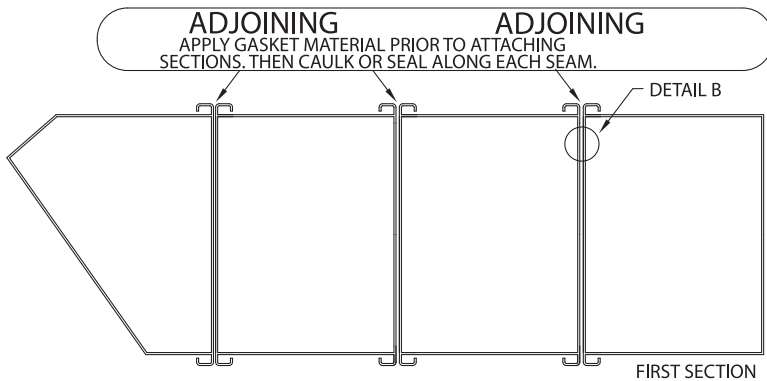
1. Apply gasket material to the end of the first section (blower, discharge, heater, etc). (See Fig. 1.)

**NOTE: One roof cap is attached to a standing seam on each section for shipping purposes only. It will be necessary to remove this PRIOR TO SLIDING SECTIONS TOGETHER. Failure to do so may damage seams, preventing proper seal.**

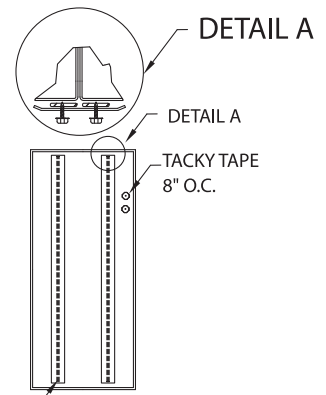
2. Slide adjoining section against the tacky taped first section. If bolt holes are provided, bolt the sections together tightly. If bolt holes are not provided, use furniture clamps to pull sections TIGHTLY together. Sections, whether bolted or not, will be held together and sealed by the standing seams and hugger strips (Fig. 2), which will be attached later.
3. Once the sections are connected, apply caulking or silicone sealant along the standing roof seam (Fig. 3) and side seams where the sections come together. (Fig.1) It is mandatory to seal the roof and side seams along the entire outside of the unit, and it is strongly suggested that the seams also be sealed along the inside of the unit, if possible.

4. Apply caulking material along the top of both sides of the standing roof seam (Fig.4). Place roof cap (Fig. 4) on top of the seam and secure it with two rows of TEK screws (one down each side), spaced approximately 8-10 inches apart down the entire length of the seam.
5. Apply two strips of tacky tape (one down each side) to the back side of each hugger strip (Fig. 2). Secure hugger strip with two rows of TEK screws (one down each side) spaced approximately 8-10 inches apart down the entire length of the seam.
6. After hugger strips are installed, caulk around the edges to complete the seal.
7. Repeat this process for each section as it is attached. The number of sections varies by application.

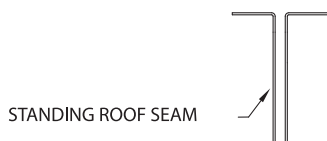
**NOTE: HOOD REQUIRES ADDITIONAL, INSTALLER PROVIDED, SUPPORT.**



**FIGURE 1**

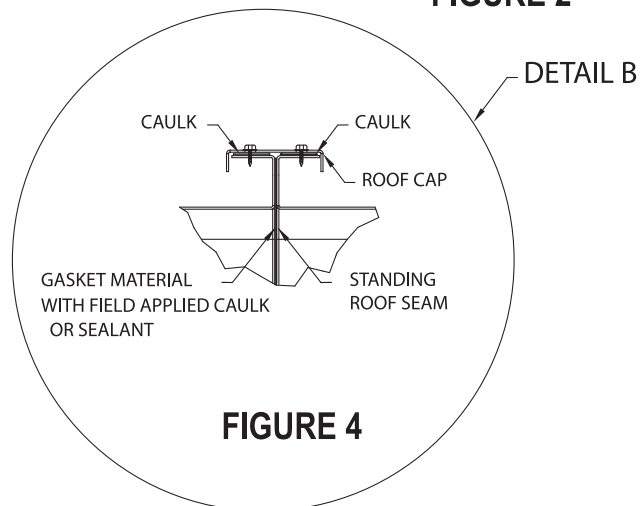


**FIGURE 2**



STANDING ROOF SEAM

**FIGURE 3**



**FIGURE 4**

## SECTION IV - PRE START-UP

***Do not attempt start-up without completely reading and understanding this manual, along with the Digital Control System user manual.***

### **Pre Start-Up**

The owners representative or equipment operator should be present during start-up to receive instructions on care and adjustments of the equipment.

All equipment has been factory tested, adjusted, metered and inspected to meet conditions set at the time the order was placed. Only minimal adjustments should be required. All information in this service manual is typical. All products are semi-custom and changes may occur.

**CAUTION: Line side of disconnect may be energized. Follow proper “lockout/tagout” procedures.**

**NOTE: All servicing and adjustments of the Direct Gas-Fired unit should be performed by a qualified service engineer.**

Perform a visual inspection, internally and externally, to make sure no damage has occurred and that everything is secure. This inspection is very important and should be completed with greatest care given to detail. A good pre-start inspection will insure against possible unit damage on start-up and will save valuable analysis time.

1. Check that the physical condition of the unit exterior is acceptable.
2. Check that the insulation inside of unit is properly secured.
3. Remove all shipping blocks, brackets and bolts from supply fan base with optional isolation base.
4. Check all terminals for loose connections and inspect all wiring terminations to insure that all crimped connections are tight.
5. Inspect all fan and motor bearings and lubricate if necessary.

**CAUTION: DO NOT RUPTURE GREASE SEALS.**

6. Inspect pulleys and belts for tightness, tension and alignment. **Do not overtighten belts.**
7. Check set screws on all bearings, pulleys, fans and couplings for tightness.
8. Check voltage supplied to disconnect switch; the maximum voltage variation should not exceed  $\pm 10\%$ . Phase voltage unbalance must not exceed 2%.
9. Check that all relays are securely plugged into the electronic relay board.

10. Check thermostat(s) for normal operation.
11. Check to ensure all manual reset safety devices have been reset and limits are in the normal operating position.
12. Check that system duct work is installed and free from obstructions.
13. Check that fans turn free in housing.
14. Check that the area around the unit is clear of flammable vapors or containers of flammable liquids.
15. Check that all piping connections, particularly unions, are tight. Check all gas piping for leaks using a soap bubble solution. The most common types of problems found relative to the gas train itself is foreign material within the gas piping. This will interfere with the proper operation of the gas train components and burner. Purge all air from gas lines per gas codes.
16. Check that all accessories requiring field wiring have been properly installed.
17. Check burner for proper location and alignment.
18. Check that filters, filter stops, accessories and ship loose items are installed correctly.
19. Check that vent lines (if applicable) are run to atmosphere on gas regulators and pressure switches for indoor units. Vent lines should terminate outside the building, with a turndown elbow and bug screen. Note that some units will use vent limiters and vent lines are not required. If vent lines are even partially plugged, this will interfere with proper venting of pressure control devices.
20. Check that all manual gas shut-off valves are closed.
21. Check that inlet gas pressure is the same as shown on the rating plate.
22. When failure or malfunction of this heater creates a hazard to other fuel burning equipment, (e.g. when the heater provides make-up air to a boiler room), the heater is to be interlocked to open inlet air dampers or other such devices.
23. Motor overload relay setting should match the motor's nameplate full load amperage.
24. Check that dampers and linkages are free to move, and that linkages are tight.
25. The unit may require that a Return Airflow Station be field installed. Be sure all tubing connections are in the correct location as shown in drawing #C000643.
26. **If inlet duct is attached to the heater, a purge timer must be provided and set to purge 4 times the inlet duct volume.**

**Purge time in seconds =  $\frac{4 \times L \times W \times H \times 60}{\text{SCFM}}$**

**L = duct length in feet, W = duct width in feet, H = duct height in feet, SCFM = rating plate air throughput.**

**Refer to the electrical schematic for the proper circuit placement. Purge timer P/N 65.0711.00.**

This equipment has been electrically and fire tested prior to shipment. However, during transit control setpoints can change, and wiring can come loose. Do not assume controls are defective until all associated setpoints and wiring are checked.

**If you do not have the optional BACview 6 (KP-01) keypad display it will be difficult to troubleshoot any alarm that may occur on the unit. To reset most alarms on the I/O Zone 583 Controller (UC-01) without a BACview 6 keypad display, simply turn the power off and back on at the unit disconnect. If you have a BACview 6 keypad display the alarm can be reset remotely or at the I/O Zone 583 Controller.**

### Suggested Control Settings

(Refer to Digital Control System user manual for default settings)

TS-02	Space Temperature Sensor.....	Customer Discretion
KP-01	Keypad/Display Module.....	Customer Discretion
MP-05	Damper Control Potentiometer ...	Customer Discretion
MP-15	Unit Enable Potentiometer .....	Customer Discretion
PS-04	Low Gas	
	Pressure Switch .....	1.0" W.C.
PS-07	High Gas	
	Pressure Switch .....	125% above burner firing rate
PS-12	Clogged Filter Switch .....	Adjust to field condition
PT-13	Building Pressure Transducer...	Adjust to field condition
FL-02	High Temperature Limit (Manual) .....	185° F

### Suggested Tools and Instruments

Volt/Ohm Meter	Thermometer
Tachometer	Ammeter
Manometer (0-10" W.C.)	Microammeter
Standard Hand Tools	D.C. Volt Meter
Gas Pressure Gauge (0-35 lbs.)	BACview 6

## BEFORE ATTEMPTING TO START THE HEATER, READ THE TYPICAL SEQUENCE OF OPERATION AS SHOWN BELOW:

### Typical Sequence of Operations Note:

This sequence is written for only the burner safety and operating portion of the heater. Other control systems for dampers, mixing boxes, and temperature controls are included in the unit typical sequence of operation and/or wiring diagram:

1. With main supply air fan(s) on, thermostat setpoint calling for heat, and all switches and operating controls in their normal position, the heater will go through a pre-purge sequence. Pre-purge timing is not adjustable and is approximately 10 seconds.
2. With pre-purge timing complete, the pilot solenoid valve and ignition transformer are energized. The pilot flame will be established and sensed by the flame sensor.
3. Ignition transformer is de-energized and pilot valve remains on.
4. Main fuel valve(s) will open. The main burner flame will be established.
5. Once the thermostat is satisfied, the pilot and main fuel valve(s) will be de-energized. Main supply fan(s) will continue to run.

### Check Safety Shutdown Performance

**WARNING: Fire or explosion hazard. Can cause property damage, severe injury or death. Perform the safety shutdown test as part of Start-Up procedure and any time work is performed on the gas system.**

**NOTE: Read steps 1 through 7 before starting, and compare to the safety shutdown or safety lockout tests recommended for the intermittent pilot (IP) ignition module. Where different, use the procedure recommended for the module.**

1. Turn off gas supply.
2. Set thermostat or controller above room temperature to call for heat.
3. Watch for ignition spark following prepurge. See IP module specifications.
4. Time the length of the spark operation. See the IP module specifications.
5. After the module locks out, open the manual gas cock and make sure no gas is flowing to the pilot or main burner.
6. Reset the flame safeguard relay (RE-02).
7. Operate system through one complete cycle to make sure all controls operate properly.

## SECTION V - UNIT START-UP GENERAL

Before attempting to start the heater read and understand the the sequence of operations and electrical schematic, and the Digital Control System user manual.

**WARNING:** During installation, testing, servicing and trouble shooting of this product, it may be necessary to work with live electrical components. Have a qualified licensed electrician or other individual who has been properly trained in handling live electrical components to perform these tasks. Failure to follow all electrical safety precautions when exposed to live electrical components could result in death or serious injury.

Make sure all manual gas valves are closed.

Make sure all doors and service panels have been closed or replaced.

Turn main disconnect switch off. Check the incoming line voltage to match unit rating plate rating. If voltage is over  $\pm 10\%$  of nameplate rating or phase voltage unbalance is over 2%, notify contractor or power company.

### Fans Are Enabled And Disabled By The Following:

#### MDT And MRT Standard:

By rotating the remote “Temperature Setpoint” knob (MP-15).

Clockwise will **enable** the fans.

Counterclockwise will **disable** the fans.

#### MRT-PRO With Smart Room Sensor:

To **enable** the fans and place the unit in the Occupied Mode press the “Manual On” button on the face of the (TS-02) MRT-PRO room sensor. Pressing the “Warmer” button will add 30-minute increments of time for a total of 9-hours of operating time. To **disable** the fans and place unit in the Unoccupied Mode press and hold down the “Manual On” button. Alternately pressing the “Manual On” button will also decrease the amount of operating time until it reaches zero and turns the fan off.

#### MRT Expert or MDT Expert With A BACview (KP-01):

To **enable** the fans go to “Unit Modes” and enter [MANUAL], this mode will enable the fans.

To also **enable** the fans go to “Unit Modes” and enter [AUTO], this mode has four different functions that control the fans and unit operation. They are a Time Clock, Heating and Cooling Night Setbacks, and signal from an external source to an auxiliary digital input.

To disable the fans go to “Unit Modes” and enter [OFF].

**NOTE:** A BACview or PC is required to change Unit Modes. For a more detailed control sequence see the Digital Control System User Manual.

If power supply meets requirements, turn main disconnect switch on and Enable fans. Damper opens (if applicable). Blower fan turns on. See operating modes in Digital Control System user manual.

Disable the fans. Check supply blower for proper rotation.

**NOTE:** To change rotation of the blower, simply interchange any two (2) of the line leads of the motor starter for three (3) phase motors. On single phase motors refer to motor nameplate.

Enable the fans. Check for proper blower rpm. Check that all motor amp draws do not exceed rating plate ratings and overloads are set to motor rating plate amps.

Check all dampers for proper operation, and linkage does not bind, see “Sequence of Operation”, and Digital Control System user manual for damper control modes.

Disable the fans.

**CAUTION:** While performing startup or servicing the unit when the ambient temperature is warm, care must be taken not to damage the optional lube lines on the bearings when the burner is in high fire.

### Setting The Pilot Flame

**NOTE:** Before attempting to light the pilot and main burner you need to review Section X for proper Manifold and Valve Adjustments. A BACview 6 or PC will be required to change setpoints.

Check the gas supply pressure by replacing the plug fitting on the pilot line with a pressure gauge having appropriate range, and opening the manual pilot valve. Check that the pressure reading is within the specified range on the rating plate.

**NOTE:** To adjust gas pressure on supply lines where a regulator has been installed (to reduce the inlet pressure to rating plate maximum pressure), remove dust cap of main gas regulator and turn adjusting screw clockwise to increase pressure or counter-clockwise to decrease pressure.

### **Honeywell Flame Safeguard Control**

A keyboard display module (Honeywell #S7800A1142) is recommended to read the flame signal, and is a good troubleshooting device. A V.O.M. can also be used on the DC voltage test jacks marked “+” and “-” on flame amplifier.

Open pilot and first main gas shut-off valves **slowly**. Last main gas shut-off valve before burner must remain closed at this time. Reset high-low gas pressure switches (if applicable). Check pilot and main gas lines for leaks using soap solution.

### **Heat is Enabled By The Following:**

#### **MDT And MRT Standard:**

To **enable** the heat, rotate the “**Temperature Setpoint**” knob (**MP-15**) clockwise to the desired setpoint above the actual air temperature. The allowable temperature range is 55° to 90°F.

#### **MRT-PRO With Smart Room Sensor:**

To **enable** the heat, press the “**Warmer**” or “**Cooler**” button on the face of the remote **MRT-Pro** room sensor (**TS-02**) to the desired room setpoint. Each push of the button changes the temperature setpoint by 1° F. The setpoint can be changed a maximum of  $\pm 10^\circ\text{F}$  from the default of 65°F. **Changing the heating setpoint also changes the cooling setpoint.**

#### **MRT Expert or MDT Expert With A BACview (KP-01):**

To enable the heat, scroll through the “Setpoints” menu in the BACview and enter the desired room Heating Occupied and Unoccupied Setpoints.

#### **Energy Savings Modes:**

**There are 3 Energy Savings Modes that could disable the burner.**

**NOTE: A BACview or PC is required to change Setpoints. For a more detailed control sequence, see the Digital Control System Users Manual.**

Enable the fans and burner, then reset burner relay (RE-02).

Unit will run for 10 seconds before ignition trial, if all safety and limits are made.

**NOTE: Do not leave the Run/Test switch on the flame safeguard relay (RE-02) in the test position during (PFEP) for more than 60 seconds. This will cause the control program to go into a Burner Status Alarm. This alarm can be reset by recycling power to the unit.**

**CAUTION: You will have approximately three (3) minutes before the unit shuts down on Freezestat (Low Discharge Temperature), if you have disconnected plug wires TS-01 and TS-03. Referred to in Section X.**

**NOTE: 3 OR 4 TRIALS MAY BE NEEDED TO PURGE AIR FROM PILOT LINE. IF BURNER HAS MAIN FLAME ROD OR SCANNER, YOU WILL NEED TO DISABLE TIMER CIRCUIT (RE-75).**

**NOTE: Pilot regulator adjustment may be needed if the adjustment of the needle valve does not yield the required reading. Typical adjustment of the needle valve is 1-1/2 to 2 turns open. Watch D.C. voltmeter carefully. The reading should be steady and between 2.0 to 5.0 volts D.C. If the reading is too low, slowly turn the needle valve in or out until satisfactory readings are obtained.**

When pilot is adjusted, shut the burner off by disabling the fans and heat.

#### **Setting Main Flame**

Reconnect power to main flame sensor (RE-75) if applicable. Install manometer at test port on the last tee of the burner manifold, or MR valve test port. Make sure the Run/Test switch on (RE-02) is in the run position.

**Slowly** open all manual gas shut-off valves.

Enable fan and heat. After “pilot proven”, main gas valve opens and burner lights.

Adjust high fire pressure reading (from manometer) to match Normal Manifold Pressure firing rate shown on unit rating plate. Take care not to damage optional lube lines.

**Refer to Valve Adjustment instructions in Section X for setting high and low fire gas pressure settings.**

The high fire setting must be made before adjusting low fire. Adjust the high fire setting according to the Maxitrol Valve Adjustment instructions in Section X. The high fire setting **must not** exceed the pressure stated on the rating plate.

**When adjusting low fire, there should be a continuous flame along the entire burner length without any blowout spots.** Main burner flame sensor must be activated, if applicable. Burner must hold in low fire for approximately 10 seconds before modulating up.

Check flame signal with burner cycling through full firing range and burner profile damper operation (if applicable).

Cycle pilot and burner several times to insure smooth light off.

There should be a continuous spark for ten (10) seconds with pilot gas supply turned off.

Check pilot and main gas lines for leaks.

Main flame is now set. Make sure burner modulates and turn thermostat to the desired setting.

### **Safety Controls Check All**

A. Flame Safeguard – Close last manual gas valve before main burner. Operate unit in Heat mode. After pilot flame has been established, close manual pilot gas valve. The flame safeguard must trip out within 15 seconds. (See Safety Shutdown Performance on page 10.

B. Firestats – These limit controls are not adjustable and are checked at the factory. Reset the red button(s) to be sure they are ready for operation. Contact factory if these switches fail to reset.

C. Gas Pressure Switches – The low pressure switch will trip out and must be reset before resuming operation when the inlet gas valve is turned off during operation. The high pressure switch may be checked out by reducing the setting of its trip point to unit operating pressure. It should then trip out and shut off the burner. Return the adjustment to its original setting and reset to resume operation.

D. Air Pressure Switches – The high air pressure switch is checked by removing the sensing tube from the entering air side of the burner and gently blow into the switch connection. Switch operation will shut off the burner. Recycle is automatic when the sensing tube is replaced. The low air pressure switch is checked by removing the sensing tube from the leaving air side of the burner. Switch operation will shut off the burner. Recycle is automatic when the sensing tube is replaced.

E. Adjustable Temperature and Limit Controls – The limit controls are checked by adjusting control settings to a lower temperature setting while the unit is operating on high fire and observing cutoff. The controls should be reset to settings shown below:

### **Cooling is Enabled By The Following:**

#### **MDT And MRT Standard:**

To enable the **cooling**, rotate the “**Temperature Setpoint**” knob (MP-15) clockwise to the desired setpoint below the actual air temperature. The allowable temperature range is 55° to 90°F.

#### **MRT-PRO With Smart Room Sensor:**

To **enable** the cooling, press the “**Warmer**” or “**Cooler**” button on the face of the remote **MRT-Pro** room sensor (**TS-02**) to the desired room setpoint. Each push of the button changes the temperature setpoint by 1° F. The setpoint can be changed a maximum of  $\pm 10^\circ\text{F}$  from the default of 73°F. **Changing the cooling setpoint also changes the heating setpoint.**

#### **MRT Expert or MDT Expert With A BACview (KP-01):**

To **enable** the cooling, scroll through the “**Setpoints**” menu in the BACview and enter the desired room **Cooling Occupied and Unoccupied Setpoints.**

#### **Energy Savings Mode:**

**Energy Savings Mode 4 can disable the cooling.**

**NOTE: The cooling outputs are protected by an anti-cycle timer which has a 3 minute off/3 minute on delay. A BACview or PC is required to change Setpoints. For a more detailed control sequence, see the Digital Control User Manual.**

## **SECTION VI - UNIT SHUTDOWN**

### **A. Extended Shutdown —**

1. Disable the heating and cooling for 30 seconds, then disable the fan.
2. Close all manual gas valves.
3. Open the main electrical disconnect switch.
4. If the unit is to remain idle for an extended period, the blower and motor shafts should be rotated by hand to spread the grease over the bearings.

### **B. Emergency Shutdown ONLY —**

1. Open the main electrical disconnect switch.
2. Close the main manual gas valve.

## SECTION VII - TROUBLE SHOOTING

### HONEYWELL RM7897A1002, RM7897C1000 7800 SERIES RELAY MODULES

#### PRINCIPAL TECHNICAL FEATURES

The RM7897 provides all customary flame safeguard functions as well as significant advancements in safety, annunciation, and system diagnostics.

#### Safety Shutdown (Lockout) Occurs if:

1. INITIATE PERIOD
  - a. Purge card is not installed or removed.
  - b. Purge card is bad.
  - c. Configuration jumpers have been changed (after 200 hours) - Fault Code 110.
  - d. AC line power errors occurred, see Operation.
  - e. Four minute INITIATE period has been exceeded.
2. STANDBY PERIOD
  - a. Airflow lockout feature is enabled and the airflow switch does not close after ten seconds or within the specified purge card timing.
  - b. Flame signal is detected after 240 seconds.
  - c. Ignition/pilot valve terminal is energized.
  - d. Main valve terminal is energized.
  - e. Delayed main valve terminal is energized (RM7897C).
  - f. Internal system fault occurred.
  - g. Purge card is removed.
  - h. Purge card is bad.
  - i. Preignition Interlock open.
3. PREPURGE PERIOD
  - a. Airflow lockout feature is enabled and the airflow switch opens.
  - b. Ignition/pilot valve terminal is energized.
  - c. Main valve terminal is energized.
  - d. Delayed main valve terminal is energized (RM7897C).
  - e. Internal system fault occurred.
  - f. Purge card is removed.
  - g. Purge card is bad.
  - h. Flame signal is detected for 30 seconds.
  - i. Preignition interlocks open during stand by.
4. PILOT FLAME ESTABLISHING PERIOD (PFEP)
  - a. Airflow lockout feature is enabled and the airflow switch opens.
  - b. No flame signal at end of PFEP.
  - c. Ignition/pilot valve/intermittent pilot valve terminal is not energized.
  - d. Main valve terminal is energized (RM7897A).
  - e. Delayed (second stage) main valve terminal is energized (RM7897C).
  - f. Internal system fault occurred.
  - g. Purge card is removed.
  - h. Purge card is bad.
5. MAIN FLAME ESTABLISHING PERIOD (MFEP) (RM7897A, terminal 21)
  - a. Airflow lockout feature is enabled and the airflow switch opens.
  - b. Ignition terminal is energized.
  - c. Ignition/pilot valve terminal is not energized.
  - d. Main valve terminal is not energized.
  - e. Delayed main valve terminal is energized.
  - f. Loss of flame signal
  - g. Internal system fault occurred.
  - h. Purge card is removed.
  - i. Purge card is bad.
6. RUN PERIOD
  - a. No flame present (JR2 removed).
  - b. Airflow lockout feature is enabled and the airflow switch opens.
  - c. Interrupted pilot valve terminal is energized (RM7897A, terminal 21).
  - d. Main valve terminal is not energized.
  - e. Delayed main valve terminal is not energized (RM7897C).
  - f. Internal system fault occurred.
  - g. Purge card is removed.
  - h. Purge card is bad.
  - i. Ignition terminal is energized.

#### OPERATION

##### Sequence of Operation

The RM7897A has the operating sequences listed below; see Fig. 5 and 6. The RM7897A LED provide positive visual indication of the program sequence: POWER, PILOT, FLAME, MAIN and ALARM.

##### Initiate

The RM7897A Relay Module enters the INITIATE sequence when the relay module is powered. The RM7897A can also enter the INITIATE sequence if the relay module verifies voltage fluctuations of +10/-15% or frequency fluctuations of  $\pm 10\%$  during any part of the operating sequence. The INITIATE sequence lasts for ten seconds unless the voltage or frequency tolerances are not met. When not met, a hold condition is initiated and displayed on the optional KDM for at least five seconds; when met, the INITIATE sequence restarts. If the condition is not corrected and the hold condition exists for four minutes, the RM7897A locks out.

## SECTION VII - TROUBLE SHOOTING *continued*

Causes for hold conditions in the INITIATE sequence:

1. AC line dropout detection.
2. AC line noise that can prevent a sufficient reading of the line voltage inputs.
3. Low line voltage brownouts.

The INITIATE sequence also delays the burner motor starter from being energized and de-energized from an intermittent AC line input or control input.

### Standby

The RM7897A is ready to start an operating sequence when the operating control input determines a call for heat is present. The burner switch, limits, operating limit control and all microcomputer-monitored circuits must be in the correct state for the relay module to continue into the PREPURGE sequence.

### Normal Start-Up Prepurge

The RM7897A Relay Module provides PREPURGE timing selectable from two seconds to thirty minutes with power applied and the operating control indicating a call for heat.

1. The Airflow Interlock, burner switch, Run/Test switch and all microcomputer-monitored circuits must also be in the correct operating state.
2. The motor output, terminal 4, is powered to start the PREPURGE sequence.
3. The Airflow Interlock input closes ten seconds into PREPURGE or within the specified purge card timing; otherwise, a recycle to the beginning of PREPURGE or lockout occurs, depending on how the Airflow Switch selectable jumper (JR3) is configured.

### Ignition Trials

1. Pilot Flame Establishing Period (PFEP):
  - a. When the PFEP begins:
    - (1) The pilot valve and ignition transformer, terminal 21 is energized. The RM7897A has an intermittent pilot valve, terminal 8 and interrupted pilot valve, terminal 21.
    - (2) Flame must be proven by the end of the ten second PFEP (four seconds if Configuration Jumper JR1 is clipped) to allow the sequence to continue. If a flame is not proven by the end of PFEP, a safety shutdown occurs.
    - (3) The pre-ignition interlock is ignored throughout the trial for ignition state.

2. Main Flame Establishing Period (MFEP):
  - a. After PFEP, and with the presence of flame, the main fuel valve, terminal 9, is powered. If a flameout occurs, the relay module locks out or recycles (depending on status of jumper JR2) within 0.8 or 3 seconds, depending on the Flame Failure Response Time (FFRT) of the amplifier.
  - b. The RM7897A (terminal 21) has a ten second MFEP. After the Ignition Trials, the interrupted pilot valve, terminal 8 is de-energized. If a flameout occurs, the relay module locks out or recycles (depending on status of jumper JR2) within 0.8 or 3 seconds, depending on the amplifier FFRT.

### Run

1. The RM7897C has a delayed main valve that is energized once the RUN period is entered.
2. The relay module is now in RUN and remains in RUN until the controller input, terminal 6, opens, indicating that the demand is satisfied or a limit has opened.

### Post Purge

After demand is satisfied or a limit opens, de-energizing terminal 6, the Ignition/Pilot valve, main valve and delayed main valve, terminals 8, 9, and 21 are de-energized. The blower motor, terminal 4, remains powered during the specified programmed time. The Pre-Ignition Interlock closes within the first five seconds of Post Purge.

### Run/Test Switch

The Run/Test Switch is located on the top side of the relay module, see Fig. 4. The Run/Test Switch allows the burner sequence to be altered as follows:

1. In the measured PREPURGE sequence, the Run/Test Switch, placed in the TEST position, causes the PREPURGE timing to stop.
2. In the Pilot Flame Establishing Period, the Run/Test Switch, placed in the TEST position, stops the timer during the first eight seconds of a ten-second PFEP selection or during the first three seconds of a four-second PFEP selection. It allows for pilot turn-down test and other burner adjustments. This activates a fifteen-second flameout timer that permits pilot flame adjustment without nuisance safety shutdowns. The Run/Test Switch is ignored during PFEP for the C relay module if terminals 8 and 9 or 9 and 21 are jumpered.

**IMPORTANT: When the relay module is switched to the TEST mode, it stops and holds at the next Run/Test Switch point in the operating sequence. Make sure that the Run/Test Switch is in the RUN position before leaving the installation.**

## SECTION VII - TROUBLE SHOOTING *continued*

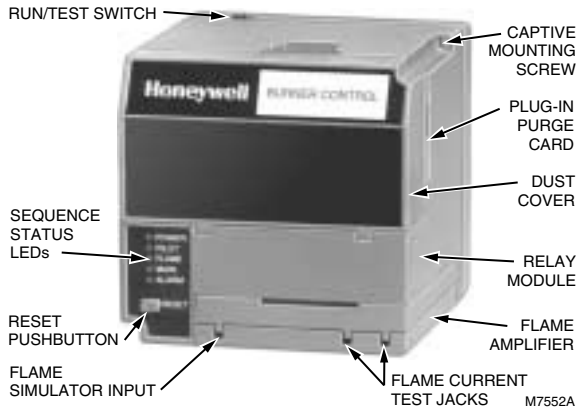
### SETTINGS AND ADJUSTMENTS

#### Selectable Site-Configurable Jumpers

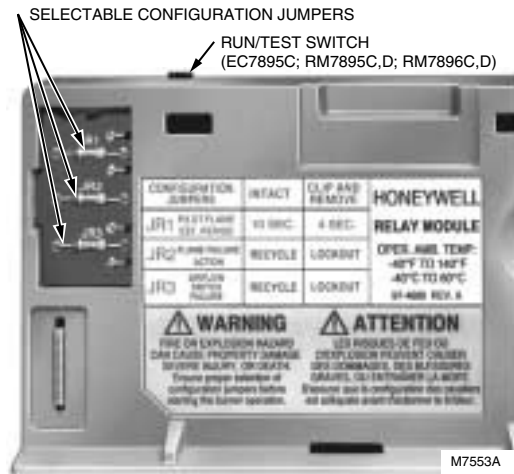
The relay module has three site-configurable jumper options, see Fig. 6 and Table 7. If necessary, clip the site-configurable jumpers with side cutters and remove the resistors from the relay module.

**SERVICE NOTE:** Clipping and removing a site-configurable jumper enhances the level of safety.

**Figure 5 - Sequence Status LEDs**



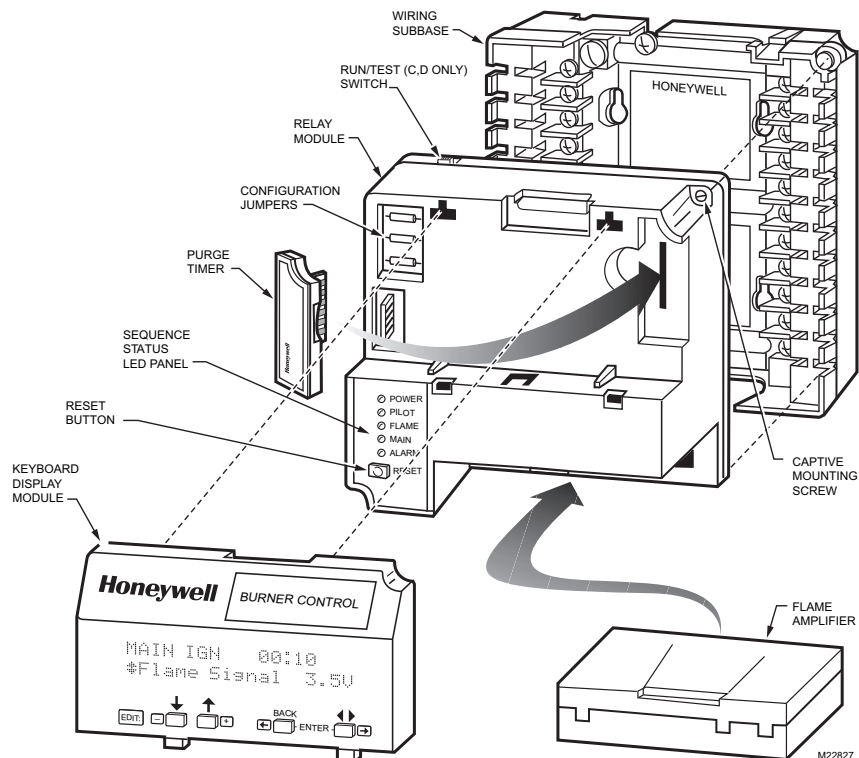
**Figure 6 - Selectable Site-Configurable Jumpers**



**Table 7 - Site-Configurable Jumper Options**

Jumper Number	Description	Intact	Clipped
JR1*	Pilot Flame Establishing Period (PFEP)	10 Seconds	4 Seconds
JR2	Flame Failure Action	Recycle	Lockout
JR3	Airflow Switch (ILK) Failure	Recycle	Lockout

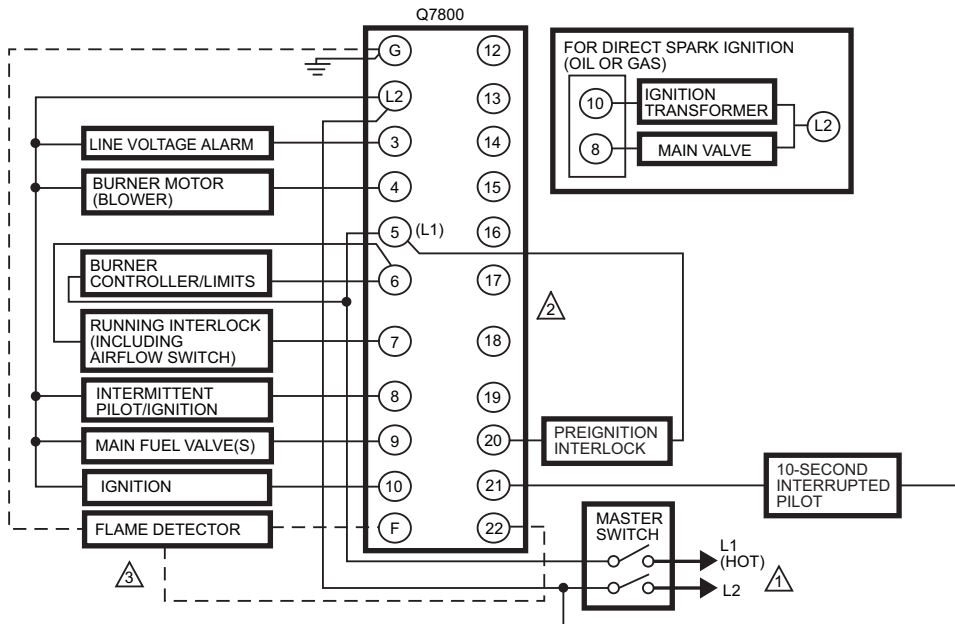
**IMPORTANT:** Clipping and removing a jumper after 200 hours of operation causes a nonresettable Fault 110. The relay module must then be replaced.



**Figure 4 - RM7897A,C Relay Module Exploded View**

## SECTION VII - TROUBLE SHOOTING *continued*

### Figure 2 - Wiring Subbase and Sequence Chart for RM7897A



	INITIATE (INITIAL POWERUP ONLY)	STANDBY	00 TIMED PREPURGE	00 PFEP 10 SEC. 4 SEC. IF JR1 CLIPPED	10 MFEP	20 RUN	00 POSTPURGE	STANDBY	
LED DISPLAY	● POWER	● POWER	● POWER	● POWER	● POWER	● POWER	● POWER	● POWER	
	○ PILOT	○ PILOT	○ PILOT	● PILOT	● PILOT	● PILOT	○ PILOT	○ PILOT	
	○ FLAME	○ FLAME	○ FLAME	● FLAME	● FLAME	● FLAME	○ FLAME	○ FLAME	
	○ MAIN	○ MAIN	○ MAIN	○ MAIN	● MAIN	● MAIN	○ MAIN	○ MAIN	
	○ ALARM	○ ALARM	○ ALARM	○ ALARM	○ ALARM	○ ALARM	○ ALARM	○ ALARM	
BURNER			BURNER/BLOWER MOTOR (5)						
			(10) IGN.						
			INTERMITTENT PILOT (8)						
			INTERRUPTED PILOT (21)						
			MAIN VALVE (9)						
OPERATING CONTROLS AND INTERLOCKS			LIMITS AND BURNER CONTROLLER CLOSED (L1) TO (6)						
			RUNNING INTERLOCKS CLOSED (6) TO (7)						
			PREIGNITION INTERLOCK CLOSED (5) TO (20)				PII		
FLAME SIGNAL			SAFE START CHECK		FLAME PROVING		SSC		

⚠ 1 120 VAC, 50/60 HZ POWER SUPPLY. PROVIDE DISCONNECT MEANS AND OVERLOAD PROTECTION AS REQUIRED.

⚠ 2 DO NOT CONNECT ANY WIRES TO UNUSED TERMINALS.

⚠ 3 SEE FLAME DETECTOR SPECIFICATIONS FOR CORRECT WIRING.

⚠ 4 PROGRAMMED ON SETUP USING S7800A1142 DISPLAY.

⚠ 5 PURGE TIME DEPENDS ON WHICH ST7800 IS INSTALLED.

M22728B

## SECTION VII - TROUBLE SHOOTING *continued*

The POWER LED provides fault identification when the Relay Module locks out on an alarm. Fault identification is a series of fast- and slow-blinking LED lights. The fast blinks identify the tens portion of the fault code (three fast blinks is 30), while the slow blinks identify the units portion of the fault code (two slow blinks is 2). Three fast blinks followed by two slow blinks would be fault code 32. This identifies a running interlock on during STANDBY. (See following Table for Blinking Fault Code List.)

The LED code repeats as long as the fault exists. To clear the fault, press the RESET button.

**Blinking Fault Codes and Recommended Troubleshooting**

Fault Code	System Failure	Recommended Troubleshooting
Code 1-1 *Low AC Line Voltage*	Low AC Line detected.	<ol style="list-style-type: none"> <li>1. Check the relay module and display module connections.</li> <li>2. Reset and sequence the Relay Module.</li> <li>3. Check the 7800 power supply and make sure that frequency and voltage meet specifications.</li> <li>4. Check the backup power supply, as appropriate.</li> </ol>
Code 1-2 *AC Quality Problem*	Excessive noise or device running on slow, fast, or AC line dropout detected.	
Code 2-1 *Unexpected Flame Signal*	Flame sensed when no flame is expected during STANDBY or PURGE.	<ol style="list-style-type: none"> <li>1. Check that flame is not present in the combustion chamber; correct any errors.</li> <li>2. Make sure that the flame amplifier and flame detector are compatible.</li> <li>3. Check the wiring and correct any errors.</li> <li>4. Remove the flame amplifier and inspect its connections. Reseat the amplifier.</li> <li>5. Reset and sequence the relay module.</li> <li>6. If the code reappears, replace the flame amplifier and/or the flame detector.</li> <li>7. If the fault persists, replace the relay module.</li> </ol>
Code 2-2 *Flame Signal Absent*	No-flame time present at the end of the Pilot Flame Establishing Period; lost during the Main Flame Establishing Period or during RUN.	<ol style="list-style-type: none"> <li>1. Measure the flame signal. If one exists, verify that it meets specifications.</li> <li>2. Make sure that the flame amplifier and flame detector are compatible.</li> <li>3. Inspect the main fuel valve(s) and valve connection(s).</li> <li>4. Verify that the fuel pressure is sufficient to supply fuel to the combustion chamber. Inspect the connections to the fuel pressure switches. Make sure they are functioning properly.</li> <li>5. Inspect the Airflow Switch and make sure that it is functioning properly.</li> <li>6. Check the flame detector sighting position; reset and recycle. Measure the flame signal strength. Verify that it meets specifications. If not, refer to the flame detector and/or flame amplifier checkout procedures in the installation instructions.</li> <li>7. Replace the flame amplifier and/or the flame detector, if necessary.</li> <li>8. If the fault persists, replace the relay module.</li> </ol>
Code 2-3 *Flame Signal Overrange*	Flame signal value is too high to be valid.	<ol style="list-style-type: none"> <li>1. Make sure the flame detector and flame amplifier are compatible.</li> <li>2. Remove the flame amplifier and inspect its connections. Reset the flame amplifier.</li> <li>3. Reset and sequence the relay module.</li> <li>4. Check the flame detector sighting position; reset and recycle. Measure flame strength. Verify that it meets specifications. If not, refer to the flame detector and/or flame amplifier checkout procedures in the installation instructions.</li> <li>5. If the code reappears, replace the flame amplifier and/or the flame detector.</li> <li>6. If the fault persists, replace the relay module.</li> </ol>
Code 3-1 *Running/ Interlock Switch Problem*	Running or Lockout Interlock fault during Prepurge.	<ol style="list-style-type: none"> <li>1. Check wiring; correct any errors.</li> <li>2. Inspect the fan; make sure there is no air intake blockage and that it is supplying air.</li> <li>3. Make sure the Lockout Interlock switches are functioning properly and the contacts are free from contaminants.</li> <li>4. Reset and sequence the relay module to Prepurge (place the TEST/RUN Switch in the TEST position, if available). Measure the voltage between terminal 7 and G (ground); 120 Vac should be present. Switch TEST/RUN back to RUN.</li> <li>5. If steps 1 through 4 are correct and the fault persists, replace the relay module.</li> </ol>

### Blinking Fault Codes and Recommended Troubleshooting

Fault Code	System Failure	Recommended Troubleshooting
Code 3-2 *Running/ Interlock On During Standby*	Lockout Interlock powered at improper point in sequence or On in Standby.	<ol style="list-style-type: none"> <li>1. Check wiring to make sure that the Lockout Interlocks are connected properly between terminals 6 and 7. Correct any errors.</li> <li>2. Reset and sequence the relay module.</li> <li>3. If the fault persists, measure the voltage between terminal 6 and G (ground), then between terminal 7 and G. If there is 120 Vac at terminal 6 when the controller is off, the controller switch may be bad or is jumpered.</li> <li>4. If steps 1 through 3 are correct and there is 120 Vac at terminal 7 when the controller is closed and the fault persists, check for a welded or jumpered Running Interlock or Airflow Switch. Correct any errors.</li> <li>5. If steps 1 through 4 are correct and the fault persists, replace the relay module.</li> </ol>
Code 3-3 *VPS in Improper State*	VPS (Valve Proving Switch) in wrong state during VPS Test.	<ol style="list-style-type: none"> <li>1. Check wiring, making sure upstream valve is connected to terminal 9 and downstream valve is connected to terminal 17.</li> <li>2. Conduct Valve Seat leakage test using a manometer.</li> <li>3. Reset and sequence the relay module; if fault repeats, test VPS (connected to terminal 16) is functioning properly; replace if necessary.</li> <li>4. Reset and sequence the relay module.</li> <li>5. If fault persists, replace the relay module.</li> </ol>
Code 4-1 *Purge Card Problem*	No purge card or the purge card timing has changed from the original configuration.	<ol style="list-style-type: none"> <li>1. Make sure the purge card is seated properly.</li> <li>2. Inspect the purge card and the connector on the relay module for any damage or contaminants.</li> <li>3. Reset and sequence the relay module.</li> <li>4. If the fault code reappears, replace the purge card.</li> <li>5. Reset and sequence the relay module.</li> <li>6. If the fault code persists, replace the relay module.</li> </ol>
Code 4-2 *Wiring Problem/ Internal Fault*	Pilot (ignition) valve terminal, main valve, ignition or Main Valve 2 was on when it should be off.	<p><b>⚠ WARNING</b>  <b>Electrical Shock Hazard; Fire or Explosion Hazard.</b>  <b>Can cause severe injury, death or property damage.</b>  Remove system power and turn off power supply.</p> <ol style="list-style-type: none"> <li>1. Remove system power and turn off fuel supply.</li> <li>2. Check wiring; correct any errors.</li> <li>3. inspect Pilot Fuel Valve(s), both places, and connections.</li> <li>4. Reset and sequence the relay module.</li> <li>5. If the fault persists, replace the relay module.</li> </ol>
Code 4-3 *Flame Amplifier Problem*	Flame not sensed, or sensed when it should be on or off.	<ol style="list-style-type: none"> <li>1. Check wiring; correct any errors.</li> <li>2. Make sure the flame amplifier and flame detector are compatible.</li> <li>3. Remove the flame amplifier and inspect the connections. Reseat the amplifier.</li> <li>4. Reset and sequence the relay module.</li> <li>5. If the code reappears, replace the flame amplifier and/or the flame detector.</li> <li>6. If the fault persists, replace the relay module.</li> </ol>
Code 4-4 *Configuration Jumper Problem*	The configuration jumpers differ from the sample taken at startup.	<ol style="list-style-type: none"> <li>1. Inspect the jumper connections. Make sure the clipped jumpers were completely removed.</li> <li>2. Reset and sequence the relay module.</li> <li>3. If the fault persists, replace the relay module.</li> </ol>
Code 5-1 *Preignition Interlock*	Preignition Interlock fault.	<ol style="list-style-type: none"> <li>1. Check wiring and correct any errors.</li> <li>2. Check Preignition Interlock switches to assure proper functioning.</li> <li>3. Check fuel valve operation.</li> <li>4. Reset and sequence the relay module; monitor the Preignition Interlock status.</li> <li>5. If the fault persists, replace the relay module.</li> </ol>
Code 5-2 *High Fire Sw. or Low Fire Sw.*	Either High Fire Switch or Low Fire Switch failure.	<ol style="list-style-type: none"> <li>1. Check wiring and correct any errors.</li> <li>2. Reset and sequence the relay module.</li> <li>3. Use manual motor potentiometer to drive the motor open and closed. Verify at motor switch that the end switches are operating properly. Use RUN/TEST switch if manual potentiometer is not available.</li> <li>4. Reset and sequence the relay module.</li> <li>5. If the fault persists, replace the relay module.</li> </ol>

### Blinking Fault Codes and Recommended Troubleshooting

Fault Code	System Failure	Recommended Troubleshooting
Code 5-3 *Man-Open Sw.; Start Sw. or Control On*	Man-Open Switch, Start Switch or Control On in the wrong operational state.	<ol style="list-style-type: none"> <li>1. Check wiring and correct any errors.</li> <li>2. Make sure that the Manual Open Valve Switch, Start Switch and Control are operating properly.</li> <li>3. Stat Switch held iOni too long.</li> <li>4. Reset and sequence the relay module.</li> <li>5. Reset and sequence the relay module. If the fault persists, replace the relay module (RM7838A1014; RM7838B1013 or RM7838C1004 only).</li> </ol>
Code 6-1 *Internal Faults*	Relay Module self-test failure.	<ol style="list-style-type: none"> <li>1. Reset and sequence the relay module.</li> <li>2. If fault reappears, remove power from the device, reapply power, then reset and sequence the relay module.</li> <li>3. If the fault persists, replace the relay module.</li> </ol>
Code 6-2 *Internal Faults*	Relay Module Self-Test failure.	<ol style="list-style-type: none"> <li>1. Reset and sequence the relay module.</li> <li>2. If fault reappears, remove power from the device, reapply power, then reset and sequence the relay module.</li> <li>3. If fault does not repeat on the next cycle, check for electrical noise being copied into the relay module through the external loads or possibly an electrical grounding issue.</li> <li>4. If the fault persists, replace the relay module.</li> </ol>
Code 6-3 *Device Specific*	Fault with special OEM input circuits.	<ol style="list-style-type: none"> <li>1. Check wiring and operation of special OEM inputs.</li> <li>2. Reset and sequence the relay module.</li> <li>3. If fault reappears, remove power from the device, reapply power, then reset and sequence the relay module.</li> <li>4. If the fault does not repeat on the next cycle, check for electrical noise being copied into the relay module through the external loads or possibly an electrical grounding issue.</li> <li>5. If the fault persists, replace the relay module.</li> </ol>
Code 6-4 *Accessory Fault*	Unused at this time.	—
Code 7-7 *Unused*	Unused at this time.	—

The following is a simplified list of possible problems and typical causes and remedies. However, it does not cover all possibilities, and is intended as a guide only. **You might also need to reference the Digital Control System User Manual for additional troubleshooting and diagnostics.**

**WARNING:** Many of the steps listed on the following pages require electrical cabinet and blower access while the unit is powered. High voltage and moving parts are present, and these steps should be performed by qualified service personnel. If any of the controls requiring manual reset were at fault this is an indication of a problem with the system that should be investigated.

## SECTION VII - TROUBLESHOOTING *continued*

### Fan and Heat Mode

Symptom	Cause	Remedy
A. Blower does not operate.	<ol style="list-style-type: none"> <li>1. Low or no voltage.</li> <li>2. Circuit breaker open.</li> <li>3. Customer interlock not closed or connected.</li> <li>4. Fan is disabled.</li> <li>5. Time clock, night setback thermostat, or field installed controls open.</li> <li>6. Freeze protection tripped. (low discharge temperature)</li>   <li>7. DO-1 on UC-01 not energized.</li>   <li>8. RE-57 contacts open.</li>   <li>9. Damper motor not operating, its end switch not making, or the damper is binding.</li>   <li>10. Overload Protection on motor starter tripped.</li> <li>11. Belts loose or broken.</li> <li>12. Bearings seized.</li> <li>13. Motor may be burned or incorrectly wired.</li> <li>14. Motor overheating.</li> </ol>	<ol style="list-style-type: none"> <li>1. Check power source.</li> <li>2. Check and replace.</li> <li>3. Close or connect customer interlock.</li> <li>4. Enable the fan.</li> <li>5. Check time clock, night setback thermostat and field installed controls for proper settings.</li> <li>6. Reset freeze stat by interrupting power. Check for proper setpoint and burner operation.</li> <li>7. See Digital Control System User Manual.</li> <li>8. Check power source and/or replace.</li> <li>9. Check for power at damper motor and that end switch has been wired correctly to the N.O. (normally open) contact. Check that the linkage is clear and not binding.</li> <li>10. Push reset button on starter and check amps.</li> <li>11. Turn off power and check belts.</li> <li>12. Check and/or replace.</li> <li>13. Turn off power and check motor and wiring.</li> <li>14. Check burner firing rate.</li> </ol>
B. No voltage at flame safeguard relay (RE-02) input terminal and the fan is enabled.	<ol style="list-style-type: none"> <li>1. Heat mode is disabled.</li> <li>2. Auxiliary switch on starter not closed (ST-01).</li> <li>3. Air flow switches open.</li>   <li>4. Outside air temperature higher than Heating Economizer Setpoint.</li> <li>5. DO-2 or RE-28 not energized.</li>   <li>6. RE-27, 56, or 65 contacts open.</li> <li>7. High temperature limit thermostat open.</li>   <li>8. High-low gas pressure switch open (if applicable).</li> <li>9. Field supplied purge timer open (if applicable).</li> </ol>	<ol style="list-style-type: none"> <li>1. Enable the heating mode.</li> <li>2. Check auxiliary circuit wiring and contact.</li> <li>3. Adjust the air flow and external static pressure to match the rating plate (Do not adjust switch setpoint).</li> <li>4. Check setpoint for proper setting.</li>   <li>5. See Digital Control System User Manual.</li> <li>6. See Multiplexed Voltage Value Chart.</li> <li>7. Reset control and correct problem before restarting.</li>   <li>8. Check gas pressure and reset switch.</li> <li>9. Check for power, replace if necessary.</li> </ol>
C. Flame safeguard relay (RE-02) goes into safety shutdown (lockout).	<ol style="list-style-type: none"> <li>1. See technical cut sheet on flame safeguard relay.</li> </ol>	<ol style="list-style-type: none"> <li>1. Determine the cause of (lockout). Push reset button on flame safeguard relay.</li> </ol>

(Refer to Digital Control System User Manual for additional troubleshooting suggestions)

## SECTION VII - TROUBLESHOOTING *continued*

### Heat Mode *continued*

Symptom	Cause	Remedy
D. Pilot does not light after prepurge has timed out (10 seconds) and voltage is present on flame safeguard output terminals.	<ol style="list-style-type: none"> <li>1. Manual pilot shut-off valve closed.</li> <li>2. Inlet gas pressure lower than required gas pressure</li> <li>3. No gas through pilot regulator with inlet gas pressure ok.</li> <li>4. No gas through pilot solenoid.</li> <li>5. Type of gas (natural - LP) supplied different from factory required type. Note: components may change.</li> <li>6. Flame detection system not sparking or sensing pilot flame. (See spark rod diagram in Section IX.)</li> <li>7. No voltage on secondary side of ignition transformer.</li> </ol>	<ol style="list-style-type: none"> <li>1. <b>Slowly</b> open valve.</li> <li>2. Increase gas pressure.</li> <li>3. Clear obstruction in vent orifice/line or replace if defective.</li> <li>4. Check for correct installation and voltage. Correct or replace.</li> <li>5. Replace with factory required type of gas.</li> <li>6a. UV Sensor - clean lens and sight tube and check wiring and spark plug.</li> <li>6b. Flame Rod - assure rod is in flame, check wiring and flame rod.</li> <li>7. Check wiring or replace transformer if correct.</li> </ol>
E. Pilot does not light after prepurge has timed out and there is no voltage at flame safeguard relay output terminals.	<ol style="list-style-type: none"> <li>1. Flame safeguard relay Run/ Test switch in Test position or functioning problem.</li> </ol>	<ol style="list-style-type: none"> <li>1. Place in run position (see technical cut sheet on flame safeguard relay).</li> </ol>
F. No heat with pilot ok and voltage is present at flame safeguard relay output terminals.	<ol style="list-style-type: none"> <li>1. Manual gas shut-off valve closed.</li> <li>2. No gas on outlet side of regulators with inlet pressure ok.</li> <li>3. No gas on outlet side of valve or actuator with inlet pressure ok.</li> <li>4. Main flame rod or scanner not sensing main burner.</li> <li>5. RE-75 energized</li> </ol>	<ol style="list-style-type: none"> <li>1. Disable the fan and heat. <b>Slowly</b> open all manual gas shut-off valves before restarting.</li> <li>2. Clear obstruction in vent orifice/line or replace if defective.</li> <li>3. Enable the fan and heat. After 10 seconds of prepurge, pilot will light. Then after 10 seconds main valve light will come on. Check to see if all gas valves have opened. If not, check voltage at gas valve. If voltage is found to be correct, replace gas valve or actuator (see Section X on Maxitrol troubleshooting Guide for modulating valve).</li> <li>4a. Check burner for low fire adjustment.</li> <li>4b. UV Sensor - clean lens and sight tube and check wiring.</li> <li>4c. Flame Rod - be sure flame rod is in main flame, check wiring and flame rod.</li> <li>5. Check for power and/or replace.</li> </ol>

(Refer to Digital Control System User Manual for additional troubleshooting suggestions)

## SECTION VII - TROUBLESHOOTING *continued*

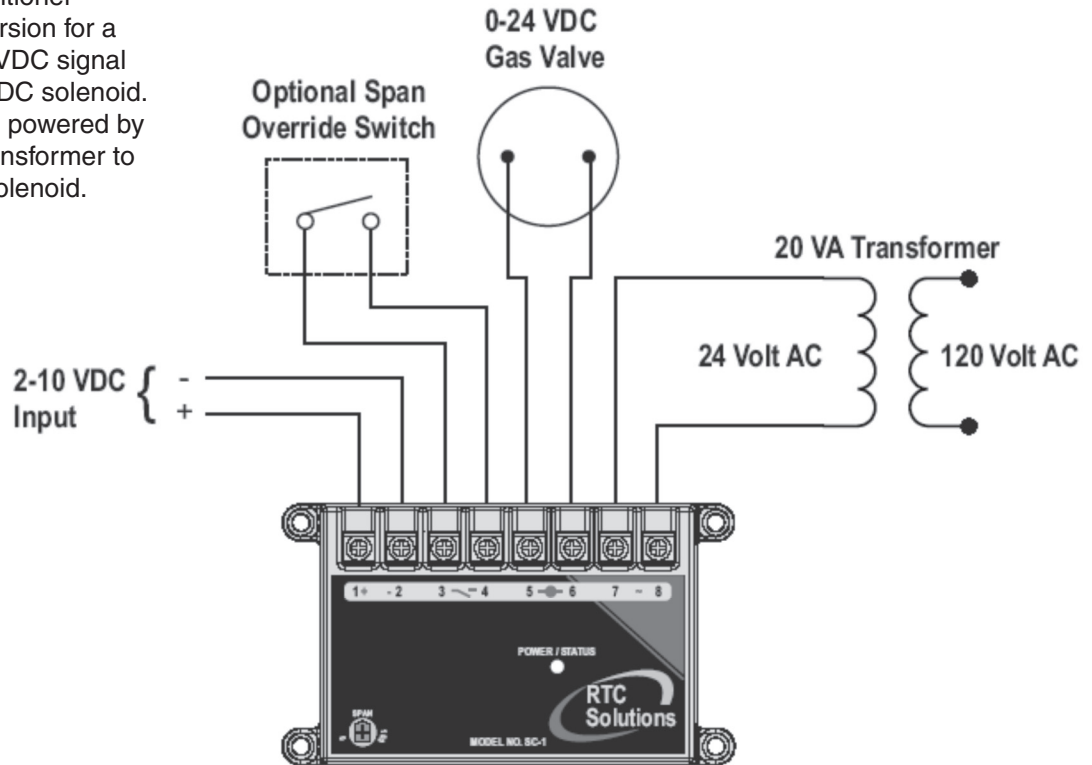
### Heat Mode *continued*

Symptom	Cause	Remedy
G. No heat with pilot ok and no voltage is present at flame safeguard relay output terminals.	1. Flame safeguard relay Run/ Test switch in Test position or functioning problem.	1. Place in Run position (see technical cut sheet on flame safeguard relay).
H. Burner will not respond to temperature.	1. For DDC System. 2. For RTC RE-26.	1. See Digital Control System User manual. 2. Refer to following troubleshooting guide for RTC controls.
I. Mixing Box with Airflow Station dampers not functioning properly. See Sequence of Operation for damper control.	1. Defective or misadjusted transducer (PT-15). 2. Transducer (PT-15) wired incorrectly. 3. Transducer (PT-15) not installed correctly. 4. Unit Control Module (UC-01) defective. 5. Unit Control Module (UC-01) not wired correctly. 6. Damper motor defective. 7. Dampers binding and/or loose.	1. Check and/or replace. See section on troubleshooting PT-15. 2. Check wiring. 3. Install correctly. See section on troubleshooting PT-15. 4. Check and/or replace. Contact Factory. 5. Check wiring. 6. Check and/or replace. 7. Check and repair.
J. Return air/outside air or discharge air/profile damper operation not functioning properly (see sequence of operation for damper control).	1. Building Pressure Transducer (PT-13), Damper Control Potentiometer, or null switch defective or not calibrated. 2. Building Pressure Transducer (PT-13), Damper Control Potentiometer, or null switch not wired correctly. 3. Building Pressure Transducer (PT-13), Damper Control Potentiometer, or null switch not installed correctly. 4. Unit Control Module (UC-01) defective. 5. Unit Control Module (UC-01) not wired correctly. 6. Two position switch defective. 7. Damper motor defective. 8. Dampers binding and/or loose.	1. Check and/or replace components. See section on trouble shooting PT-13. 2. Check wiring. 3. Install correctly. See section on trouble shooting PT-13 and manufacturer's cut sheet. 4. Check and/or replace. Contact Factory. 5. Check wiring. 6. Check and/or replace. 7. Check and/or replace. 8. Check and repair.
K. Burner will not come on in low speed.	1. Low air flow switch open. 2. Profile damper and/or motor not closing.	1. Check to make sure velocity is correct. 2. Check and/or replace.
L. Flame length too long in low speed.	1. High fire set incorrectly. 2. Profile damper not operating correctly and/or damper motor defective.	1. See Section X for Manifold and Valve Adjustments. 2. Check and/or replace.

(Refer to Digital Control System User Manual for additional troubleshooting suggestions)

## TROUBLESHOOTING GUIDE FOR AMPLIFIER (RE-26)

The SC-1 signal conditioner provides signal conversion for a high impedance 2-10VDC signal source to drive a 24VDC solenoid. The control should be powered by an isolated 24VAC transformer to drive up to a .5A dc solenoid.



*Span Override Switch* - When terminals 3 & 4 are shorted together the span setting is ignored forcing the ratio to 100%.

*Start Up Delay* - The unit will pause for 10 seconds after power is applied to begin driving the output.

### *Power/Status LED*

A solid green LED indicates power and normal operation.

A slow blinking green LED indicates power but the 10 second start up delay has not completed.

A fast blinking green LED indicates the the input signal is out of range or may be reversed.

## TROUBLESHOOTING GUIDE

### Modulating Discharge Temperature (MDT or MDT EXPERT) Controls

Portions reproduced with permission from Maxitrol® Company

Symptom	Possible Cause	Field Test	Remedy
A. No Gas Flow with DO-2 on UC-01 energized.	1. Modulating valve improperly installed.	1. Arrow on side of valve should point in direction of gas flow.	1. Install properly.
B. Continuous Low Fire (Electronics Problem).	1. Short circuit or no voltage to the amplifier (RE-26). 2. Faulty amplifier (RE-26).  3. No output voltage on UC-10. 4. Jumper not connected across amplifier (RE-26) terminals 3 & 4.	1. Check for 24V AC at amplifier (RE-26) terminals 7 & 8. 2. Check item B1. Check for 0-10 VDC input signal from (UC-01) at terminals 1 & 2. Check for 0-20 VAC output signal to gas valve at terminals 5 & 6. 3. Check DC Voltage on AO-1. 4. Inspect.	1. Prove the power source.  2. If item B1 checks out and modulating voltages are still not obtained, amplifier (RE-26) may be assumed faulty. Replace.  3. Contact Factory. 4. Correct the wiring.
C. Continuous Low Fire (Electronics OK).	1. Short circuit or open circuit in Modulator Coil.  2. Plunger missing, jammed or improperly installed.	1. Measure resistance across modulator terminals 5 & 6 with connecting wires detached.  2. Inspect. Plunger should be installed to operate freely in solenoid sleeve.	1. Replace modulator head if not approximately 45-55 ohms for M611 Valve and 60-80 ohms for MR212 Valve. 2. Clean or replace plunger if necessary.
D. Incorrect Minimum Fire Erratic or Pulsating Flame.	1. Incorrect by-pass metering valve adjustment. 2. Excessive negative burner pressure.	1. See valve adjustments in Section X.  2. Close main gas supply and measure manifold pressure with blower operating. Reading should be less than 1.5" w.c. negative pressure.	1. Adjust to proper minimum fire.  2. If reading is greater than 1.5" negative pressure, check for clogged filters or other inlet air restrictions. Consult factory for other solutions.
E. Continuous High Fire (Electronics Problem).	1. Open circuit in Outside Air Temperature Sensor (TS-01) or Discharge Air Temperature Sensor (TS-03) circuit or wiring.	1. Check Outside Air Temperature Sensor (TS-01) or Discharge Air Temperature Sensor (TS-03) for open internal circuit. See Thermistor curve.	1. Replace Outside Air Temperature Sensor (TS-01) or Discharge Air Temperature Sensor (TS-03)
F. Continuous High Fire (Electronics OK).	1. Foreign object holding valve open. 2. Plunger jammed.	1. Remove bottom plate and inspect valve and seat. 2. Inspect. Plunger should be smooth and clean and operate freely in solenoid sleeve.	1. Clean seat. Clean valve or replace if necessary. 2. Clean, or if necessary, replace plunger.

(Refer to Digital Control System User Manual for additional troubleshooting suggestions)

## TROUBLESHOOTING GUIDE

Modulating Discharge Temperature (MDT or MDT EXPERT) Controls *continued*

Portions reproduced with permission from Maxitrol® Company

Symptom	Possible Cause	Field Test	Remedy
G. Incorrect Maximum Fire.	<ol style="list-style-type: none"> <li>1. Inlet pressure too low.</li> <li>2. Incorrect outlet pressure adjustment of Pressure Regulator.</li> </ol>	<ol style="list-style-type: none"> <li>1. Read pressure at inlet to modulating valve using a manometer with unit operating at full fire. Pressure should be equal to the sum of outlet pressure setting plus pressure drop of the valve.</li> <li>2. Read manifold pressure using manometer and compare with the pressure stated on the specification plate.</li> </ol>	<ol style="list-style-type: none"> <li>1. Increase inlet pressure if possible.</li> <li>2. See valve adjustments in Section X.</li> </ol>
H. Incorrect Discharge Air Temperature	<ol style="list-style-type: none"> <li>1. Unit Enable Potentiometer (MP-15) not set correctly.</li> <li>2. Discharge Air Temperature Sensor (TS-03) not reading correctly.</li> <li>3. The Heating Discharge Air Setpoint on MDT-EXPERT Control System is not set correctly.</li> </ol>	<ol style="list-style-type: none"> <li>1. Check setpoint on Unit Enable Potentiometer (MP-15)</li> <li>2. Check Discharge Air Temperature Sensor (TS-03) and wiring. See Thermistor curve.</li> <li>3. Check setpoint with BACview or PC.</li> </ol>	<ol style="list-style-type: none"> <li>1. Change to correct setpoint setting.</li> <li>2. If readings are not correct, replace Discharge Air Temperature Sensor (TS-03) or repair wiring.</li> <li>3. Change to correct setpoint. See Digital Control System User Manual.</li> </ol>
I. Burned out Transformer.	<ol style="list-style-type: none"> <li>1. Short circuit in modulator coil.</li> <li>2. Short circuit between amplifier and modulator valve.</li> </ol>	<ol style="list-style-type: none"> <li>1. Measure resistance across modulator terminals with red lead wires disconnected.</li> <li>2. Inspect wiring.</li> </ol>	<ol style="list-style-type: none"> <li>1. Replace modulator head if less than 40 ohms.</li> <li>2. Correct wiring if short is found.</li> </ol>

(Refer to Digital Control System User Manual for additional troubleshooting suggestions)

## TROUBLESHOOTING GUIDE

### Modulating Room Temperature (MRT, MRT-PRO or MRT-EXPERT) Controls

Portions reproduced with permission from Maxitrol® Company

Symptom	Possible Cause	Field Test	Remedy
A. No Gas Flow with DO-2 on UC-01 energized.	1. Valve improperly installed.	1. Arrow on side of valve should point in direction of gas flow.	1. Install properly.
B. Continuous Low Fire (Electronics OK).	1. Open circuit in modulator coil. 2. Plunger missing, jammed or improperly installed. 3. Ruptured main or balancing diaphragm.	1. Remove wires connected to amplifier terminals 5 & 6 and measure resistance. MR212 (60-80 ohms), M611 (45-55 ohms). 2. Inspect - plunger should be installed to operate freely in solenoid sleeve. 3. Disassemble valve for inspection of internal parts.	1. If proper resistance values are not observed, replace modulator head or repair wiring. 2. Clean or replace plunger if necessary. 3. Replace diaphragm if ruptured.
C. Continuous Low Fire (Electronics Problem).	1. No voltage to the amplifier. 2. Short in modulator coil circuit.  3. Faulty amplifier (RE-26).  4. No output voltage on UC-01.	1. Check for 24V AC at amplifier terminals 7 & 8. 2. Measure resistance per item B1.  3. Check for 0 – 10 VDC input signal from Unit Control Module (UC-01) at terminals 1 & 2. Check for 0 – 20 VDC output signal to gas valve at terminals 5 & 6. 4. Check voltage on AO-1.	1. Provide 24V AC to amplifier. 2. If proper resistance values are not observed, replace the modulator head or repair wiring. 3. If power source and modulator coil check out (items 5 & 6) but proper modulating voltages cannot be obtained, then amplifier may be assumed at fault. Install replacement amplifier. 4. Consult factory.
D. Incorrect Low Fire.	1. Incorrect by-pass metering valve adjustment. 2. Excessive negative burner pressure.	1. See Valve Adjustments Section X. 2. Close main gas supply and measure manifold pressure with blower operating. Should be less than 1.5" w.c. negative pressure.	1. Adjust to proper low fire. 2. If greater than 1.5" negative pressure, check equipment for clogged filters and other inlet air restrictions. For other solutions, consult factory.
E. Continuous Minimum Discharge Air Temperature.	1. Incorrect room temperature.	1a. Check Outside Air Sensor (TS-01), Space Temperature Sensor (TS-02) and Discharge Air Sensor (TS-03) for correct readings. See Thermistor curve. 1b. Check Space Temperature Sensor (TS-02) and/or Unit Enabled Potentiometer (MP-15) setpoint. 1c. Check Heating Occupied and/or Unoccupied setpoint.	1a. Replace Sensors if reading is incorrect or correct wiring. 1b. Change to correct setpoint. 1c. Change to correct setpoint.
F. Incorrect Maximum or Minimum Discharge Air Temperature.	1. Maximum or minimum heating discharge temperature setpoint not set correctly.	1. Install a BACview 6 or PC.	1. Change to correct setpoints.

(Refer to Digital Control System User Manual for additional troubleshooting suggestions)

**Control circuits external to MRT Controls can cause burner malfunction.**

**Always check manual valve to be certain gas is on, and check limit controls for normal operation.**

## TROUBLESHOOTING GUIDE

Modulating Room Temperature (MRT, MRT-PRO or MRT-EXPERT) Controls *continued*

Portions reproduced with permission from Maxitrol® Company

Symptom	Possible Cause	Field Test	Remedy
G. Continuous High Fire (Electronics Problem).	<ol style="list-style-type: none"> <li>Foreign material holding valve open.</li> <li>Plunger jammed.</li> </ol>	<ol style="list-style-type: none"> <li>Remove bottom plate and inspect valve and seat.</li> <li>Inspect - plunger should be smooth and clean and operate freely in solenoid sleeve.</li> </ol>	<ol style="list-style-type: none"> <li>Clean, replace valve and/or seat if necessary.</li> <li>Clean, or if necessary, replace plunger.</li> </ol>
H. Continuous High Fire (Electronics OK).	<ol style="list-style-type: none"> <li>Open circuit in Outside Air Temperature Sensor (TS-01) or Discharge Air Temperature Sensor (TS-03)</li> </ol>	<ol style="list-style-type: none"> <li>Measure resistance per Thermistor Curve.</li> </ol>	<ol style="list-style-type: none"> <li>If readings are incorrect, replace Outside Air Temperature Sensor (TS-01) or Discharge Air Temperature Sensor (TS-03) or repair wiring.</li> </ol>
I. Incorrect High Fire.	<ol style="list-style-type: none"> <li>Inlet pressure too low.</li> <li>Incorrect outlet pressure adjustment.</li> </ol>	<ol style="list-style-type: none"> <li>Read inlet pressure at valve, using a manometer with heater operating at full fire. Pressure should be at least equal to the sum of: outlet pressure setting and pressure drop of the valve plus 1.0" w.c.</li> <li>Read outlet pressure using manometer and compare with the pressure stated on the specification plate.</li> </ol>	<ol style="list-style-type: none"> <li>Increase inlet pressure if possible or change to larger valve. Consult factory about possibility of using special spring to reduce pressure drop on selected installations.</li> <li>See Valve Adjustments -Section X.</li> </ol>
J. Continuous Maximum Discharge Air Temperature.	<ol style="list-style-type: none"> <li>Open circuit in Discharge Air Temperature Sensor (TS-03).</li> <li>Incorrect Maximum Heating Discharge Temperature Setpoint.</li> </ol>	<ol style="list-style-type: none"> <li>Measure resistance per Thermistor Curve.</li> <li>Check to see if heater is delivering at Maximum Heating Temperature Discharge Setpoint.</li> </ol>	<ol style="list-style-type: none"> <li>If readings are incorrect, replace Discharge Air Temperature Sensor (TS-03) or repair wiring.</li> <li>If desired temperature is not reached, increase Maximum Heating Discharge Temperature Setpoint.</li> </ol>
K. Burned out Transformer. No Voltage to Amplifier.	<ol style="list-style-type: none"> <li>Short in modulator coil circuit.</li> </ol>	<ol style="list-style-type: none"> <li>Measure resistance per item B1.</li> </ol>	<ol style="list-style-type: none"> <li>If proper resistances are not observed, replace modulator head or repair wiring.</li> </ol>
L. Incorrect Space Temperature.	<ol style="list-style-type: none"> <li>Incorrect Minimum Heating Discharge Temperature Setpoint.</li> <li>Incorrect space setpoint.</li> <li>Insufficient burner capacity.</li> </ol>	<ol style="list-style-type: none"> <li>Check to see if heater is delivering at Minimum Discharge Setpoint.</li> <li>2a. Check Unit Enable Potentiometer (MP-15) Setpoint.</li> <li>2b. Check Heating Occupied and/or Unoccupied setpoint.</li> <li>3. Check to see if heater is operating at high fire.</li> </ol>	<ol style="list-style-type: none"> <li>If desired Space Temperature is not reached, increase Minimum Heating Discharge Setpoint.</li> <li>2a. Change to correct setpoint.</li> <li>2b. Change to correct setpoint.</li> <li>3. If desired Space Temperature is not reached with heater at high fire, it may be undersized. Consult Factory.</li> </ol>

(Refer to Digital Control System User Manual for additional troubleshooting suggestions)

**Control circuits external to MRT Controls can cause burner malfunction.**

**Always check manual valve to be certain gas is on, and check limit controls for normal operation.**

## TROUBLESHOOTING GUIDE

### Cooling Mode

Symptom	Cause	Remedy
A. There is no voltage at cooling relays (RE-34) (RE-35) and/or (RE-33) and the fan is enabled.	<ol style="list-style-type: none"> <li>1. Cooling mode is disabled</li> <li>2. Auxiliary switch on starter (ST-01) is not closed.</li> <li>3. Air flow switches open.</li> <li>4. Cooling Changeover and/or Economizer Setpoints not set correctly.</li> <li>5. DO-3 and/or DO-4 are not energized.</li> </ol>	<ol style="list-style-type: none"> <li>1. Enable the cooling mode.</li> <li>2. Check auxiliary circuit wiring and contact.</li> <li>3. Adjust the air flow and external static pressure to match the unit rating plate. <b>DO NOT ADJUST SWITCHES.</b></li> <li>4. Change to correct setpoints. See Digital Control User Manual.</li> <li>5. See Digital Control System User Manual.</li> </ol>
B. Cooling relays (RE-34) (RE-35) and/or (RE-33) are energized and condensing unit or evaporative cooler is not on.	<ol style="list-style-type: none"> <li>1. Cooling relays (RE-34) (RE-35) and/or (RE-33) contacts are not closed.</li> <li>2. Cooling relays (RE-34) (RE-35) and/or (RE-33) contacts are not wired correctly.</li> <li>3. Compressors or evaporative pump not running.</li> </ol>	<ol style="list-style-type: none"> <li>1. Check and/or replace.</li> <li>2. Correct wiring.</li> <li>3. See Troubleshooting Guide for your condensing unit or evaporative cooler.</li> </ol>
C. Incorrect Space Temperature.	<ol style="list-style-type: none"> <li>1. Incorrect Maximum Cooling Discharge Temperature Setpoint.</li> <li>2. Incorrect Minimum Cooling Discharge Temperature Setpoint.</li> <li>3. Unit Enable Potentiometer (MP-15) not set correctly.</li> <li>4. Cooling Occupied and/or Unoccupied setpoints not set correctly.</li> <li>5. Insufficient cooling.</li> <li>6. Condensing section or evaporative cooler is not operating correctly.</li> </ol>	<ol style="list-style-type: none"> <li>1. Decrease Maximum Cooling Discharge Temperature Setpoint. See Digital Control System User Manual.</li> <li>2. Decrease Minimum Cooling Discharge Temperature Setpoint. See Digital Control System User Manual.</li> <li>3. Change to correct setpoints. See Digital Control System User Manual.</li> <li>4. Change to correct setpoint settings. See Digital Control System User Manual.</li> <li>5. If desired Space Temperature is not reached and cooling is at full capacity, it may be undersized.</li> <li>6. See Troubleshooting Guide for your condensing unit or evaporative cooler.</li> </ol>

(Refer to Digital Control System User Manual for additional troubleshooting suggestions)

## TROUBLESHOOTING GUIDE

### To Calibrate the Building Pressure Transducer (PT-13)

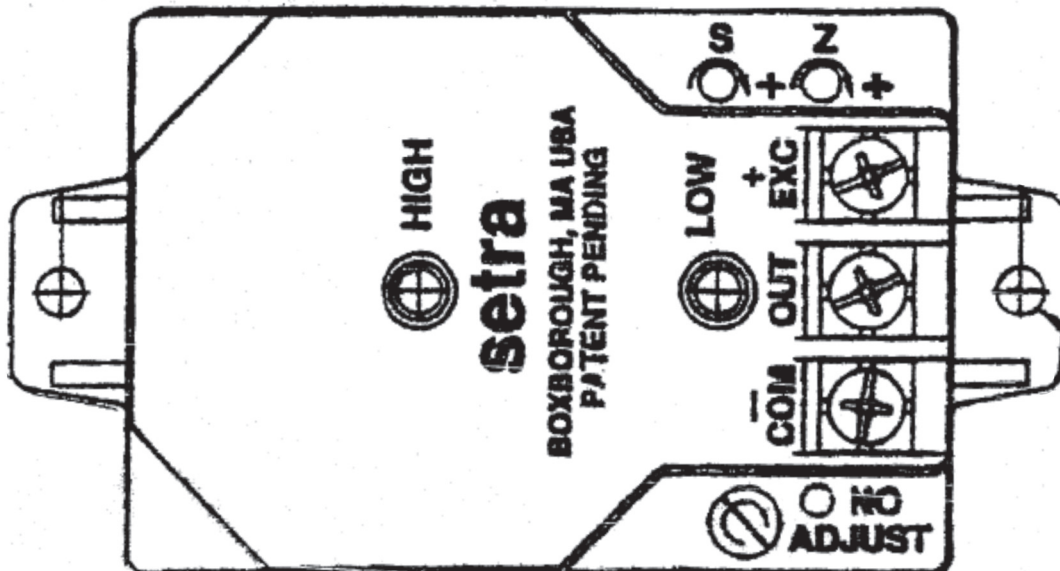
1. Remove the tubes at the Low and High pressure fittings.
2. The voltage at –COM and OUT should be 2.5 VDC. If not adjust Z (do not adjust S).
3. **Make sure the Low and High fittings are clean and clear (do not insert any sharp objects into the pressure fittings). Make sure the tubing is also clean, clear of any debris and then reinstall the tubes on the transducer. It is very important that the High tube be placed inside the building, and positioned so that air movement does not affect it. The Low side should be to atmosphere, and positioned so it is not exposed to the weather.**
4. With the use of a BACview 6 (KP-01) place the unit in the Building Pressure mode. (See the Digital Control System User Manual).
5. The voltage at –COM and OUT will vary between 0 to 5 VDC. 0 VDC means the building is in a negative pressure and should open the Outside Air/Profile and close the Return Air damper. 5 VDC means the building is in a positive pressure and should open the Return Air Damper and close the Outside Air/Profile Damper.

PT-13		
SETRA P/N	MESTEX P/N	RANGE
26510R1WBABT1C	68.0330.69	± .1 IN WC

### To calibrate the Flow Station Pressure Transducer (PT-15)

1. Remove the tubes at the Low and High pressure fittings.
2. The voltage at –COM and OUT should be 0 VDC. If not adjust Z (do not adjust S).
3. **Make sure the Low and High fittings are clean (do not insert any sharp objects into the pressure fittings) make sure the static pressure sensing pitot tubes and all tubing is also clean, clear of any debris and then reinstall the tubes on the transducer. It is very important that the Low and High tubes from the Flow Station are installed on the transducer correctly (see drawing #C000643 on page 8).**
4. With the use of a BACview 6 (KP-01) place the unit in the Calibration Mode (see the Digital Control System User Manual). You can also short across the TS-01 and TS-03 terminals on UC-01 for ten (10) seconds. This will open the Return Air damper and close the Outside Air damper. The unit will calibrate for 5 minutes. **IMPORTANT: Be sure there is no blockage in the return air duct.**
5. The voltage at –COM and OUT should be at least 2 VDC. If the voltage is less than 2 VDC contact the factory.

PT-15		
SETRA P/N	MESTEX P/N	RANGE
26510R1WDABT1C	68.0330.66	0 - 0.1 IN WC
2651R25WDABT1C	68.0330.67	0 - .25 IN WC
26510R5WDABT1C	68.0330.68	0 - .5 IN WC



## TROUBLESHOOTING GUIDE

### Checking The Burner Velocity Pressure

**PS-10 & PS-11 air switches are factory calibrated. Do not adjust.**

The permissible pressure range should be marked on the switches. If it's close to the high or low trip points of the airflow switches, you could have nuisance burner shutdowns. High Velocity Switch open means too much velocity and Low Velocity Switch open means not enough velocity across the burner profile plates.

Check the velocity pressure by disconnecting both pressure sensing tubes from the High Velocity Switch. Connect your manometer to each sensing tube so you can measure the differential pressure and then enable the fan.

**CAUTION: Be sure to turn the power and gas off to the unit before you access the burner. Follow proper "lockout/tagout" procedures.**

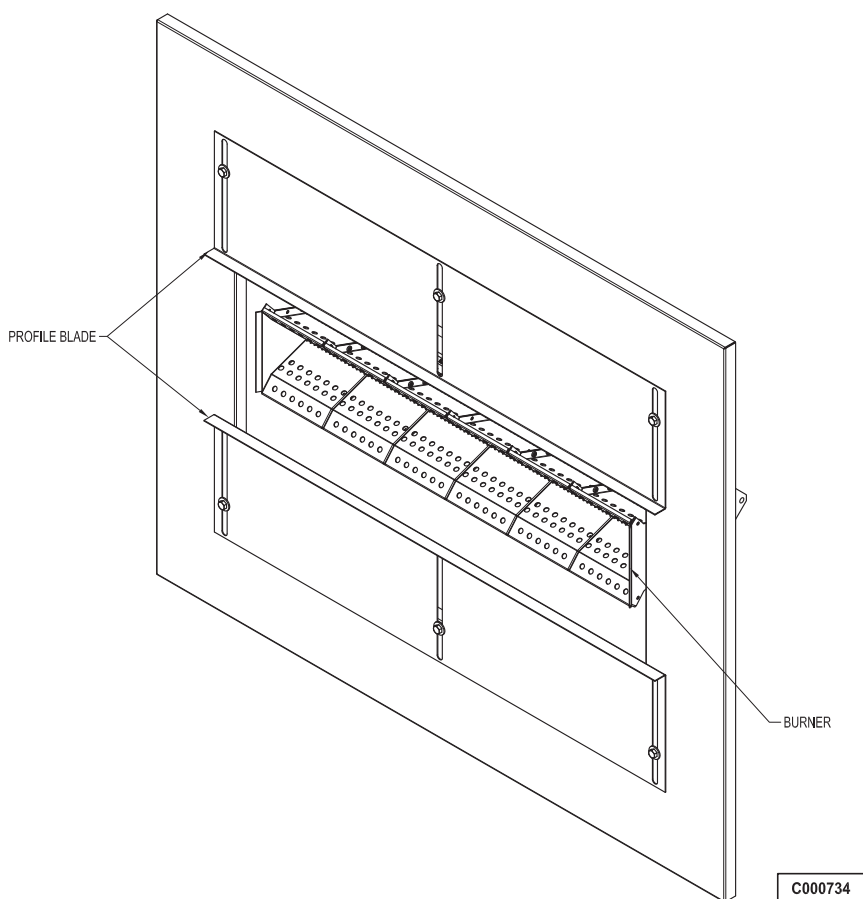
Some adjustments can be made by repositioning the burner profile plates. If the velocity will allow the High Velocity Switch to open, you can open the profile plates. If the velocity will allow the Low Velocity Switch to open, you can close the profile plates. **REMEMBER** to keep the opening between the burner and profile plates the same on both top and bottom of the burner when making these adjustments.

Depending on the motor amps, you may want to change the speed of the fan if the unit has adjustable sheaves.

Enable the burner and get it running in high fire – See Section X in this manual. Your differential pressure should now be lower. If it is near the Low Velocity Switch trip point, you need to increase the velocity. The ideal velocity is in the middle of the High Velocity Switch and Low Velocity Switch trip points.

**Don't forget to remove any jumpers and reconnect the sensing tubes to the switch.**

Call the factory if you have any questions.



## MULTIPLEXED VOLTAGE CHART

RESISTOR VALUE	RESISTOR ID	SWITCH CLOSED	OHMS IN CIRCUIT	VOLTS DC
1000	RS1	RS1,2,3,4	0	0
2000	RS2	RS2,3,4	1000	0.30
4020	RS3	RS1,3,4	2000	0.55
8060	RS4	RS3,4	3000	0.76
<b>MULTIPLEXED VOLTAGE VALUES</b>		RS1,2,4	4020	0.95
		RS2,4	5020	1.10
		RS1,4	6020	1.24
		RS4	7020	1.36
		RS1,2,3	8060	1.47
		RS2,3	9060	1.57
		RS1,3	10060	1.65
		RS3	11060	1.73
		RS1,2	12080	1.80
		RS2	13080	1.87
		RS1	14080	1.92
		NONE	15080	1.98
		UNPLUGGED	NA	3.30

IN-3	JUMPER	RS-04	MIXED AIR TEMP	= 1.36
TO	RE-56	RS-03	SAFETY CKT STATUS	= 1.73
GND	RE-09	RS-02	FLAME FAILURE	= 1.87
	SW-72	RS-01	100% OA or 100% OUTPUT	= 1.92
IN-4	RE-27	RS-04	BURNER STATUS	= 1.36
TO	RE-65	RS-03	FAN STATUS	= 1.73
GND	RE-12	RS-02	CLOGGED FILTER	= 1.87
	SW-09	RS-01	AUXILIARY UNIT ENABLE	= 1.92

### CHECK ALL TERMINAL CONNECTIONS FOR TIGHTNESS

The DC voltage is to be checked at the UC-01 board

#### **With the Fan Enabled:**

When the fan status relay (RE-65) is energized, the contacts will close and the VDC at IN-4 & GND will be 1.73.

#### **With the Fan and Burner Enabled:**

When the safety circuit relay (RE-56) is energized, the contacts will close and the VDC at IN-3 & GND will be 1.73. When the burner status relay (RE-27) is energized, the contacts will close and the VDC at IN-4 & GND will be 0.76.

## SECTION VIII - MAINTENANCE SCHEDULE AND LUBRICATION REQUIREMENTS

**WARNING: Failure to comply with the general safety information may result in extensive property damage, severe personal injury or death.**

Periodic maintenance is essential to the efficient operation and extended service life of this equipment. Failure to provide maintenance as recommended may void the equipment warranty.

### A. Maintenance Schedule

1. Daily
  - a. Check gauges, monitors, instruments and equipment settings.
2. After 8 hours of operation
  - a. Check that fan belts are tight and sheaves are aligned. The fan belts can be checked every 30 days after the first 60 days of new belt run-in. **CAUTION: Do not overtighten belts.**
  - b. Check set screws and bolts on the fan, bearings, couplings, and burner assembly.
  - c. Check gas pressure at regulator.
3. After 48 hours of operation, check bearings for any unusual vibration or excessive temperature.
4. Monthly
  - a. Check all valves, piping and connections for leaks.
  - b. Check the flame signal.
  - c. Check the fuel pressure in the fuel supply line to each heater.
  - d. Check the burner manifold pressure at full fire. **Care must be taken not to damage optional lube lines.** At low fire setting, be sure there is a continuous flame along the entire burner length without any blowout spots.
  - e. Clean the flame sensor(s) or UV sight tube(s).
  - f. Inspect filters. Clean or replace as necessary.
  - g. Inspect the main fan bearings, lubricate if necessary. See Section VIII on bearing maintenance.
  - h. Check all dampers, damper actuators and linkages. Adjust and tighten if necessary.
  - i. Ensure that there are no obstruction blocking the air supply to the heater or the air discharge from the heater.
  - j. Inspect the area and make sure that no combustible or hazardous material has been stored within the clearances as shown on the unit nameplate.
  - k. Check and clear all air sensing tubes and fittings. **CAUTION: Remove tubes from switches, transducers, and flow station before using compressed air to blow through tubing.**
  - l. Test ignition spark. There should be a continuous spark for 10 seconds with pilot gas turned off.
5. Quarterly
  - a. Complete the monthly maintenance schedule.
  - b. Inspect all drives for proper belt tension and wear.
  - c. Check the alignment of the sheaves and adjust if necessary.
  - d. Inspect all bearings set screws for tightness and lubricate bearings if necessary.
  - e. Check the pilot electrical system. Adjust if necessary.
  - f. Check the pilot assembly. Clean and adjust if necessary.
  - g. Inspect the burner carefully. Clean and adjust if necessary.
  - h. Check voltages and amp draw on main fan motor.
  - i. Check the operation of all safety controls individually.
  - j. Check the operation of the automatic gas shut off valves and check them for leakage at the pressure test ports provided.
  - k. On vertical units inspect burner clean out and drain if necessary.
  - l. **Check that the battery in (UC-01) has 3 VDC. Do not remove or replace battery with the power turned off to the control.**
6. Off Season or Yearly
  - a. Complete the monthly and quarterly maintenance schedule.
  - b. Inspect all fan wheels and housings. Clean if necessary.
  - c. Check that all fan wheels, sheaves, and couplings are securely set on the shaft.
  - d. Inspect all bearings and alignment. Adjust if necessary.
  - e. Inspect all V-belts, sheaves, and coupling inserts. Replace if necessary.
  - f. Inspect all electrical components, connections and terminals. Clean and tighten where necessary.
  - g. Test ignition spark. Adjust gap if necessary.
  - h. Clean ignition electrodes and check for cracks.
  - i. Test flame safeguard relay and replace components if necessary.
  - j. Inspect all regulators, relief valves, motorized valves, solenoid valves, vent valves, manual shut off valves and safety shut off valves. Check their operation and clean as necessary.
  - k. Ensure all vents to the atmosphere are clean and free from obstruction.
  - l. Inspect and clean all drip legs in the fuel line.
  - m. Lubricate fan motor as directed by motor manufacturer.
  - n. Inspect fan motor wiring for loose connections.
  - o. Lightly oil all door latches.
  - p. Check that cabinet is weathertight, replace door gaskets and recaulk as necessary.

**NOTE: Keep screened air intakes clear of obstructions at all times.**

**B. Lubrication Instructions**

Item	Manufacturer	Bearing Type
All 3 phase fan motors (1 HP to 100 HP) ODP, TEFC	US., Baldor or equal	Single row ball bearings
<i>Recommendation: See following note.</i>		
All 1 phase motors (Fractional HP) ODP, TEFC or TEAO	Century, G.E., or equal	Bronze sleeve bearings
<i>Recommendation: See following note.</i>		
Fractional HP single phase, ODP or TEFC	Century, G.E. or equal	Bronze sleeve bearings
<i>Recommendation: See following note.</i>		
Fan shaft bearings	Fafnir or equal	Self-aligning single row or double row ball bearings, resilient mounted
<i>Recommendation: See following note.</i>		
Dampers	Factory or equal	Sleeve
<i>Recommendation: See following note.</i>		

1. Blower Motors – Some motors require lubrication while others do not. Those that require lubrication can be identified by the presence of grease plugs in the motor casing at each end. Motors that do not have grease plugs cannot be greased and are lubricated for the life of the motor bearing.

Lubrication of motors should be done while the motor is warm and at a standstill. Remove and clean all grease plugs and insert a grease fitting in the upper hole in the motor casing at each end. (Viewed as if motor were sitting horizontally on its base). There may be one or two plugs in each end casing of the motor. Add a small amount of a clean, good grade ball bearing grease, such as Exxon Polyrex EM or equal, with a low pressure grease gun. Run the motor five minutes before removing the grease fittings and replacing the plugs.

**CAUTION: An excess of grease will overheat the bearings.**

**NOTE: On totally enclosed fan cooled (TEFC) motors, the rear end fan housing must be removed to expose the grease plugs.**

2. Pillow Block Bearings – Pillow block bearings are used on supply blower(s). Bearings have been pre-lubricated with high-quality lithium-complex base grease with an EP additive. The grease is a lithium-complex base mineral oil, NLGI Grade 2 consistency, with a base oil viscosity of ISO VG220. Re-lubrication should be done with lithium-complex thickened grease with a comparable NLGI consistency and base oil type and viscosity. Wipe all grease fittings clean before adding grease. Grease should be added slowly, in small amounts at frequent intervals while the shaft is being manually rotated.

A slight showing of grease at the seals with accompanying normal bearing temperature indicates proper lubrication. Normal temperature can range from “cool” to “hot to the touch” depending on size, speed and surrounding conditions. Excessive bearing temperature indicates faulty lubrication. An insufficient amount of grease is suggested by a bearing showing no grease at the seals, and a higher than normal temperature and noise level. Excessive leakage of grease at the seals, and a high operating temperature suggest too much grease.

Frequency of Lubrication – Frequency of lubrication depends upon operating conditions. The bearing operating temperature is the best index for determining a relubrication schedule. The following chart gives the frequency of relubrication based upon continuous operation for various operating temperatures and can be used as a satisfactory guide for determining when all ball and roller bearings should be relubricated.

Speed	Temperature	Cleanliness	Interval
100 RPM	Up to 125°F	Clean	4 to 10 months
500 RPM	Up to 150°F	Clean	1 to 4 months
1000 RPM	Up to 210°F	Clean	2 weeks
1500 RPM	Over 150°F	Clean	weekly
Any Speed	Up to 150°F	Dirty	1 week to 1 month
Any Speed	Over 150°F	Dirty	daily to 1 week
Any Speed	Any Temp.	Very Dirty	daily to 1 week
Any Speed	Any Temp.	Extreme Conditions	daily to 1 week

Roller Bearings			
100 RPM	Up to 125°F	Clean	1 – 4 months
500 RPM	Up to 150°F	Clean	1 week to 1 month

## Browning Bearing Set Screw Torque Values

Model#	Shaft Size	Torque (in-lbs)
<b>Set Screw</b>		
VPS-212	3/4	66 - 85
VPS-214	7/8	66 - 85
VPS-116	1	66 - 85
VF2S-116	1	66 - 85
VPS-219	1 3/16	66 - 85
VF4S-219	1 3/16	66 - 85
VPS-220	1 1/4	126 - 164
VPS-223	1 7/16	126 - 164
VPS-323	1 7/16	126 - 164
VF4S-227	1 11/16	126 - 164
VPS-327	1 11/16	228 - 296
VPS-231	1 15/16	228 - 296
VF4S-231	1 15/16	228 - 296
VPS-331	1 15/16	228 - 296
VPS-235	2 3/16	228 - 296
VF4S-235	2 3/16	228 - 296
VPS-236	2 1/4	228 - 296
VPS-239	2 7/16	228 - 296
VF4S-243	2 11/16	348 - 452
VPS-343	2 11/16	348 - 452
VPS-347	2 15/16	348 - 452
<b>BOA Concentric</b>		
VPB-231	1 15/16	220 - 240
VPB-331	1 15/16	220 - 240
<b>Spherical Roller</b>		
USFB5000	1 3/16	165
USFB5000	1 7/16	165
USFB5000	1 11/16	165
USFB5000	1 15/16	295
USFB5000	2 3/16	295
USFB5000	2 7/16	295
USFB5000	2 11/16	655
USFB5000	2 15/16	655
<b>Sealmaster SleeveLoc</b>		
USRB5000A 115C	1 15/16	30

**When replacing bearings refer to the manufacturer's installation instructions included with the bearing.**

### Typical Procedure For Changing The Shaft And Bearings

1. Remove protective shaft coating.
2. Remove the drive side sheave.
3. Disconnect the grease lines from the existing bearings.
4. Remove mounting bolts for bearings and remove any shims.
5. Identify the total shim thickness at each bearing and mark the bearing mount for future reference.
6. Loosen bearing and blower wheel shaft setscrews.
7. Remove the shaft from the unit by sliding the bearings and blower wheel(s) along the shaft as the shaft is extracted. Unless a blower wheel is damaged, it should be unnecessary to remove the blower wheel from the blower housing.

8. Slide the new shaft through the first blower wheel hub.
9. Once the shaft is completely through the first blower wheel, slide a bearing onto this end of the shaft by pushing on the inner ring. Do not use a hammer.
10. Slide the shaft through the next blower wheel hub and add another bearing. Continue this procedure until the shaft is through all of the blower wheels.
11. Place a bearing on each end of the shaft.
12. Replace the shims as required.
13. Install bearing mounting bolts (do not tighten) and check alignment.
14. Tighten the bearing bolts to recommended torque shown below and reattach grease lines. (When installing USRB5000A 115C bearing, see note of following page).
- 15.

<b>ASTM A307 Recommended Tightening Torque</b>		
Bolt Size	TPI	ft lbs
1/4	20	4
5/16	18	7
3/8	16	13
7/16	14	21
1/2	13	32
9/16	12	46
5/8	11	64

16. Adjust the shaft so the blower hub keyways are in the middle of the shaft keyways.
17. Adjust the shaft so it protrudes past the non-drive end bearing, the blower sheave keyway mates with the shaft keyway and the drive side sheave can be aligned with the motor sheave. Ideally, the blower sheave should be as close to the drive side bearing as possible, the motor sheave should be as close to the motor housing as possible, and the belts should be straight.
18. Be sure the shaft does not rub on or interfere with the closing of the access door.
19. Align all bearing setscrews, so that the same setscrew on each bearing is pointed in the same direction as the other bearings' setscrews.
20. Check shaft for freedom of rotation by rotating shaft by hand in both directions.
21. Place a drop of "BLUE" Loctite on the bearing setscrews and tighten all of the setscrews. Follow the mounting instructions procedure on the inside of the bearing box or accompanying instructions for proper tightening and torque values.
22. Align the blower hubs' keyway with those in the shaft. Be sure the clearance between the blower wheel and blower housing is the same on each side.
23. Rotate the shaft by hand to insure free operation. Correct any rubbing of the blowers on the housings.

24. Place a drop of "BLUE" Loctite on the blower setscrews and tighten all of the setscrews.
25. Align the blower and motor sheaves using a laser or straight edge and tighten the blower sheave to the shaft.
26. Replace the belts and tighten the motor base adjustment for the proper belt tension. Over tightening the belt tension will severely reduce belt and bearing life. Belt deflection should be approximately 1/64 inch for every inch of span length.
27. Monitor for excessive heat or vibration during operation.
28. All bearings are pre-lubricated and should not initially require greasing. See previous section for bearing maintenance instructions.

**Note: Drive side Sleevlock bearing installation (USRB5000A 115C)**

**WARNING: Do not apply grease, oil, or anti-seize compound to the tapered surface, bore, or shafting. If any of these substances are applied, equipment failure and personal injury may result.**

1. Mount all the bearings and leave all of the bolts and setscrews loose.
2. Tighten setscrews on the bearing to the tightening pattern as described in the installation sheet that comes with the bearing to a final 30 inch lbs torque while rotating the shaft. Check to make sure the insert of the bearing is centered in the bearing housing and then bolt bearing down.
3. Tighten down the bolts and setscrews on the remaining bearings per installation sheet starting from the non-drive end bearing back towards the Sleevlock while rotating the shaft.

3. Dampers – Dampers should be inspected monthly (**daily in icy or snowy weather**) for securely fastened linkages, and smooth operation. If dampers are binding or excessively noisy, then lubrication may be required. Place one drop of #20 wt. machine oil on each blade bearing, and linkage ball joint. Do not over lubricate, and wipe any excess from the area. Be sure to note that dampers over 49 inches long have intermediate bearings which require lubrication. On outdoor models with factory supplied discharge dampers, you will need to remove to top cover to access the damper bushings. Replace cover and caulk as necessary.

**C. Air Filters**

All filter banks should be equipped with a manometer or differential pressure switch to indicate when the filters are dirty. Filters should be replaced when the differential pressure across them reaches the manufacturer's recommended final value. Dirty filter elements should be replaced with a clean element of

the same type and size. In addition, the factory not only suggests, but insists, that air filters be **checked every 30 days (daily in icy or snowy weather)** and replaced with new filters (throw-away type) or cleaned (washable type) as required. Cleanable filters should be given new application of filter coating after washing to maintain optimum filter performance.

The frequency of cleaning and replacing air filters applies twelve months of the year, **where blowers are used for ventilation and heating.**

**D. Belt Tensions and Adjustments**

Belt tension is adjusted during the initial run-in and test periods at the factory. However, the belts are run as slack as possible to prevent excessive damage to the bearings, yet tight enough to prevent slippage.

It is necessary, therefore, to tighten all belts during the first few months of operation, and to **check for proper tension weekly during the first 60 days**, after which 30-day check intervals are sufficient.

**NOTE: Turn off all power to the equipment before checking belt tensions.**

**CAUTION: Do not attempt to tighten any belt or belts by changing the pitch of an adjustable pulley, as this will change the speed of a driven pulley, causing the unit to be rendered OUT OF AIR BALANCE. Do not overtighten belts.**

**Suggested Belt Tension Method is with the use of a Belt Tension Checker**

1. Check tension frequently during the first 24-48 hours of run-in operation. Ideal tension is the lowest tension at which the belt will not slip under peak load conditions. Over tensioning shortens belt and bearing life.

**Alternate Belt Tension Method**

2. To properly tension a conventional V-belt drive use the following procedure:
  - a. Measure the span length.
  - b. At the center of the span, apply a force perpendicular to the span to deflect the belt 1/64 inch for every inch of span length. For example, for a 40 inch span, apply a force that will deflect the belt 40/64 or 5/8 of an inch.
  - c. Compare the force you have applied with the values given in the table below. If the force is between the values for normal tension and 1-1/2 times normal tension, the belt tension should be satisfactory. If the belt tension is not within this range, it can be adjusted by loosening the motor mounting bolts, and adjusting the position of the motor along its base.

## B Section

small pulley diameter range in Inches	Belt Manufacturer & Type Belt	Pounds Force for Normal Tension	Pounds Force for 1½ times Normal Tension
3.4-4.2	Gates Hi-Power	4.4	6.6
4.4-4.6	Gates Hi-Power	4.9	7.4
5.8-8.6	Gates Hi-Power	5.8	8.7

Note: For recommendation of other types of belts, consult respective manufacturers.

## E. Optional Coils And Related Items

1. Coils – Coil surfaces must be kept clean of dirt and lint in order to operate at rated efficiency. Coils should be inspected on a regular basis and cleaned as required.

**CAUTION: Solutions used to clean coils must not be corrosive to metals or materials used in the manufacturer of this equipment. If cleaning solutions are applied through means of high pressure spray, care must be taken to avoid damaging the coil fins. Always follow the manufacturer’s warnings and directions for the coil cleaner you are using.**

2. Condensate Drain Pan – Periodically flush the condensate pan and drain system with a water hose.

## F. Gaskets

Gaskets are used on doors, inspection covers, some filter racks, and some outdoor air dampers. Inspect gaskets periodically and repair or replace as required.

## G. Caulking

Inspect unit and add caulking as required.

## H. Casing

Periodic cleaning of the casing is recommended to remove dirt, grease and any corrosive substances that may harm the finish. Rusted or corroded spots should be cleaned and repainted.

## I. Support Means

Inspect the entire unit and burner support means to be sure everything is firmly in place.

## J. Heater

1. At least a yearly inspection is recommended for heating installations and more frequently for process applications in year-round operation. Your own experience is the best guide in determining frequency of inspection, but as a minimum the following procedure should be followed:

- a. Shut the system down totally, disconnecting or locking out power supply so there can be no accidental start-up during inspection.
- b. Inspect the burner carefully, including upstream and downstream sides of mixing plates as well as burner body face. Note that complete burner assembly may have to be removed for proper inspection and cleaning. Any accumulation of scale or foreign material on either side of the mixing plates should be removed with a wire brush. Check visually that no holes in the mixing plates are blocked. If any burner ports are plugged (even partially) clear them with a piece of wire. See Maintenance of Gas Ports.

**WARNING: Do not enlarge burner ports or performance may be drastically affected.**

If any mixing plates are loose or missing fasteners, tighten/replace as necessary. Always use zinc plated or stainless fasteners. The mixing plates on the burner may display “hairline” cracks. These cracks are normal, and caused by thermal stresses occurring during combustion. The presence of these “hairline” cracks in no significant way affects the combustion efficiency or performance of the heater. Should a large opening develop, it may cause difficulties in cross ignition of flame across the face of the burner. If this does occur, the specific mixing plate or plates involved **must** be replaced.

- c. Put system back into operation and view burner while cycling through full firing range. This will give a visual check for blocked burner ports.

2. Inspect the flame rod and ignition electrode for dirt and moisture. Wipe off if necessary. Examine for any evidence of premature arcing. If in doubt, check continuity of flame rod to be sure it is not grounding out. Replace if required.

The porcelain on the ignition electrode must be intact - not cracked. The spark gap should be 1/8 of an inch on Mestek burners.

3. Replace all access panels which have been removed and operate the unit for a test period. Check for normal response and function of all controls.
4. Check all gas piping for possible leaks using a soap bubble solution.
5. Inspect the support means to be sure that everything is firmly anchored in place.

## SECTION IX - MESTEK LINE BURNERS

### Inspection and Maintenance of Gas Ports

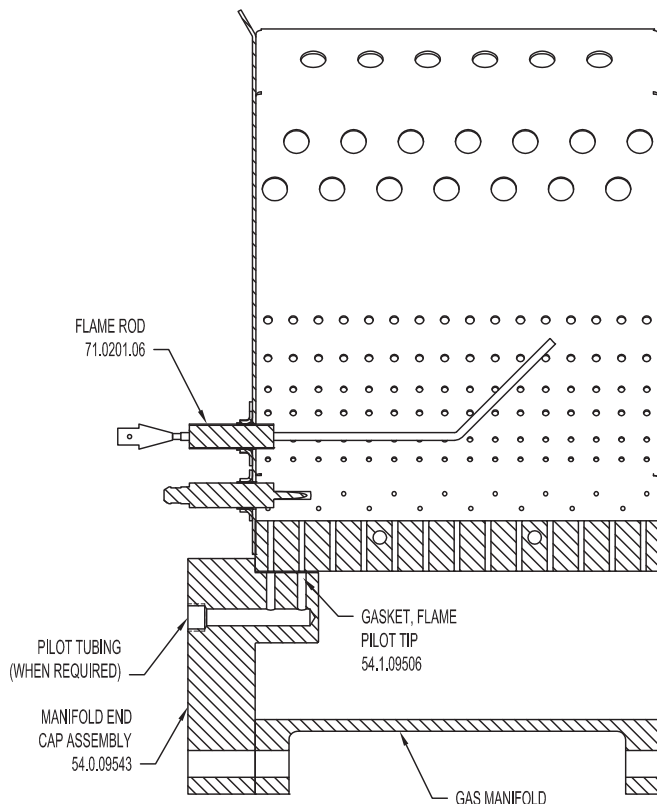
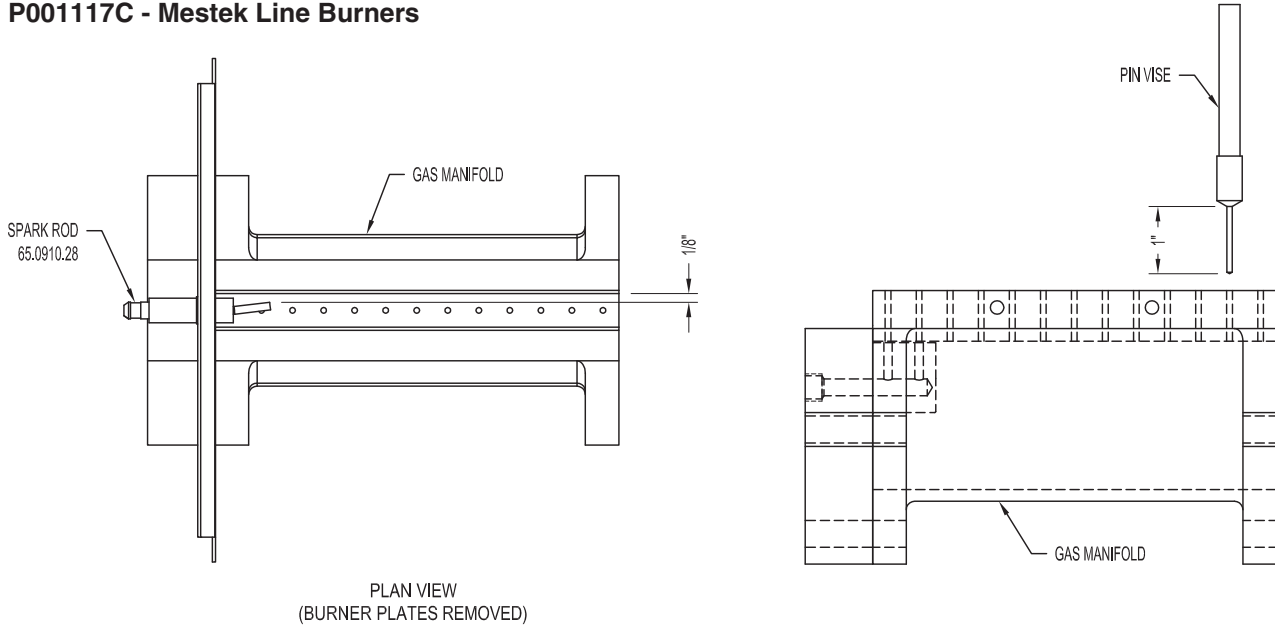
Conduct initial inspection within the first month after commissioning. Visually check the gas ports of new burner assemblies for any piping scale or debris. Use Pin Vise with drill bit to remove.

Annual inspections are normally adequate once the initial piping debris is removed. The operating conditions of the burner will determine how frequently maintenance is actually required.

Use of an electric drill motor is not suggested unless both Pin Vise and Drill can be chucked up in a vari-speed drill unit. Use caution, because it is easy to snap the bits off in a port when using a drill motor. Removal of broken bits from the gas ports is difficult.

Alternate drill size which may be used is a 5/64" (for #45).

### P00117C - Mestek Line Burners



## SECTION X - MANIFOLD AND VALVE ADJUSTMENTS

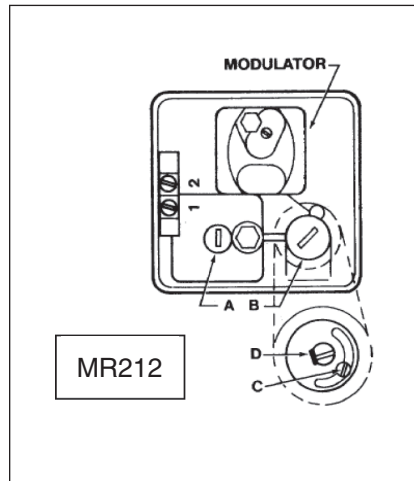
The I/O Zone 583 Controller (UC-01) must be calling for the burner to be enabled. The DO-2 light will be on and Burner Enable Relay (RE-28) needs to be energized. This will put power to the Burner Relay (RE-02). **If the outside air temperature is above the Heating Economizer 65°F Setpoint the burner will be disabled.** You will need to disconnect the plug where the Outside Air Temperature Sensor (TS-01) and Discharge Air Temperature Sensor (TS-03) are wired to the I/O Zone 583 Controller (UC-01), see High Fire and Low Fire Adjustment in following section. Reconnect the plug if you are getting close to the Freezestat lockout time, approximately 3 minutes. To reset the Freezestat alarm simply turn the power off and back on at the disconnect switch.

**NOTE: A BACview or PC is required to change settings. See the Digital Control System User Manual for a more detailed sequence of operation.**

Prior to setting high and low fire you should have your test equipment installed and be familiar with the gas valve (VG-07) and its adjustment, see High Fire and Low Fire Adjustment in following section. For High Fire Setpoint refer to rating plate on unit for Normal Manifold Pressure in inches of water column. The typical high fire flame should be blue and approximately 12 to 18 inches long with short orange to yellow tips. After high fire has been set, low fire may need to be re-adjusted. Cycle the burner several times to be sure it lights off reliably. Low fire is a visual setting.

**CAUTION: There should be a continuous flame along the entire burner length without any blow-out spots.**

### HIGH AND LOW FIRE MANIFOLD ADJUSTMENT FOR MAXITROL VALVES WITH DDC



(MR212)

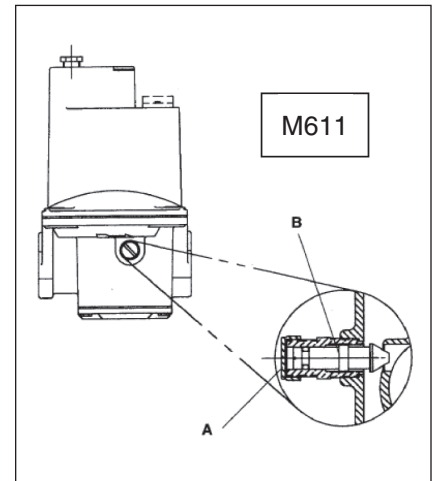
#### High Fire Manifold Adjustments

Note: Low fire may need to be set first to get the burner to light off properly.

1. Disconnect the plug where the Temperature Sensors (TS-01 and TS-03) are wired to the unit control module (UC-01). A minimum of 15vdc is required at terminals #5 and #6 on electric relay (RE-26). This causes the valve to call for continuous high fire. **Caution: The unit will shut down on freezestat after approximately 3 minutes.**
2. Remove seal cap (A) and turn regulator pressure adjusting screw to obtain normal manifold pressure (clockwise rotation increases pressure).

#### Low Fire or Bypass Adjustments

1. Disconnect wire from (RE-26) terminal #8. This causes valve to call for continuous low fire.
2. Remove cap (B) and loosen lock screw (C). Turn (D) to desired low fire adjustment. (Clockwise rotation reduces minimum flow rate.)
3. Tighten screw (C), replace cap (B), and reconnect wire to (RE-26) terminal #8.
4. Reconnect the plug back into the jack on the unit control module (UC-01).



(M611)

#### High Fire Manifold Adjustments

Note: Low fire may need to be set first to get the burner to light off properly.

1. Disconnect the plug where the Temperature Sensors (TS-01 and TS-03) are wired to the unit control module (UC-01). A minimum of 15vdc is required at terminals #5 and #6 on electric relay (RE-26). This causes the valve to call for continuous high fire. **Caution: The unit will shutdown on freezestat after approximately 3 minutes.**
2. Adjust the gas pressure regulator (GP-05) to obtain the normal manifold pressure.

#### Low Fire or Bypass Adjustments

1. Disconnect wire from (RE-26) terminal #8. This causes valve to call for continuous low fire.
2. Remove cap (A) and turn adjusting screw (B) to desired low fire adjustment. (Clockwise rotation reduces minimum flow rate.)
3. Replace cap (A) and reconnect wire to (RE-26) terminal #8.
4. Reconnect the plug back into the jack on the unit control module (UC-01).

## CIRCUIT ANALYSIS – MAXITROL GAS VALVES

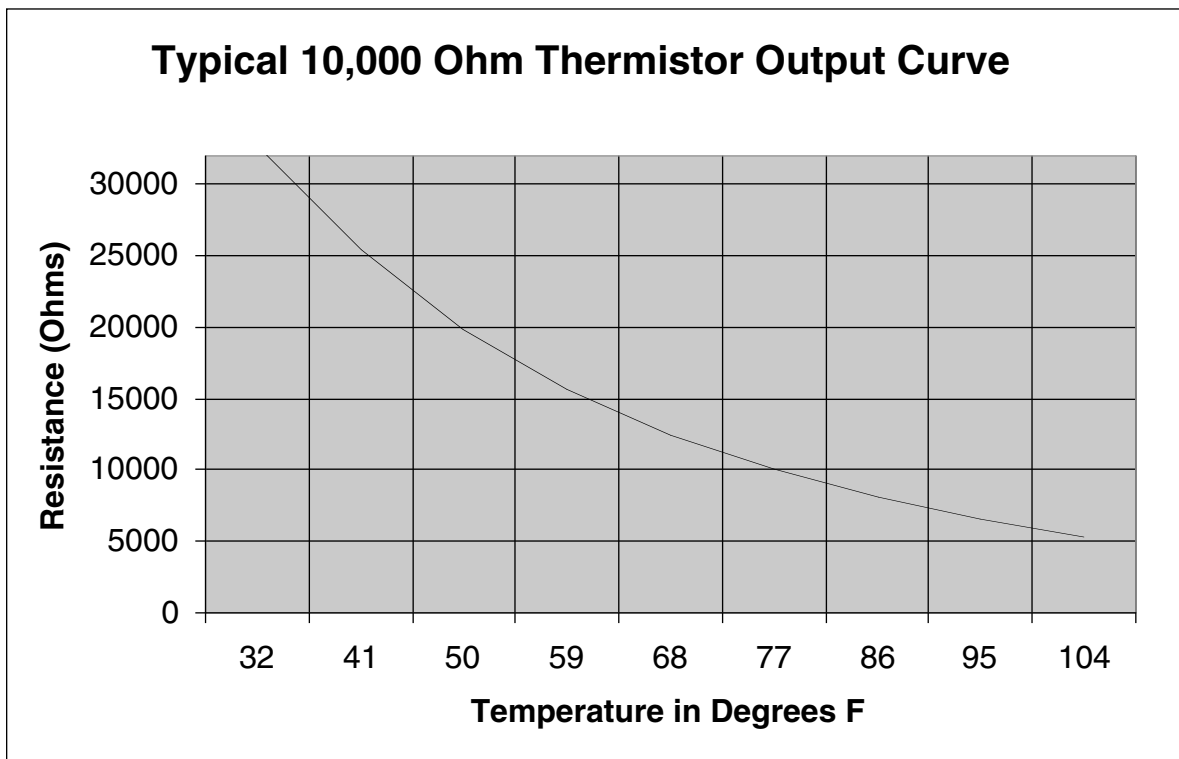
Connect a DC volt meter (capable of reading 0-24V DC) on the Modulator (M611) or Modulator-Regulator (MR212) Valve terminals.

The operation of the Valve with regard to voltage is as follows: from 0 volts to approximately 5 volts, the modulating valve should be on bypass flow with the heater operating on low or minimum fire. From approximately 5 volts to 15 volts DC, the valve should be performing its modulating function, and the heater should be firing at a modulated flow rate between low and high fire, depending upon the voltage. Above approximately 15 volts DC, the Valve should be delivering full flow to the heater and the unit should be on full fire. If the DC voltage is obtained on the Valve terminals, but the heater does not respond as described, the problem can be isolated to the valve itself or to the gas control manifold of the heater.

If the proper voltages are not obtained the problem can be isolated to the electronics and/or electronic relay (RE-26). See the Trouble Shooting Section and the Digital Control System User Manual.

See the Thermistor Output Curve in the following section.

## SECTION XI - THERMISTOR OUTPUT CURVE



## SECTION XII - REPLACEMENT PARTS

Replacement parts may be ordered from the factory. All warranty parts will be shipped freight allowed from factory for normal ground service. Warranty parts must be returned prepaid within **30 days**. Credit will be issued if part is complete, defective and returned on time.

When parts are ordered, MODEL NUMBER, SERIAL NUMBER, FACTORY ORDER (F.O.) and PART NUMBERS are required. Belts, filters, and fuses are not covered under warranty.

Dealer/Contractor Name: \_\_\_\_\_

Address: \_\_\_\_\_

City: \_\_\_\_\_

State: \_\_\_\_\_ Zip: \_\_\_\_\_ Ph: \_\_\_\_\_

## SECTION XIII - RECIRCULATION

**WARNING: On Heaters, which recirculate room air, outside ventilation air must be provided in accordance with the information shown on the heater nameplate.**

Recirculation of room air may be hazardous in the presence of:

- flammable solids, liquids and gases
- explosive materials such as grain dust, coal dust, gunpowder, etc.
- substances such as refrigerants or aerosols which may become toxic when exposed to heat or flame

Recirculation is not recommended in uninsulated buildings where outside temperatures fall below 32°F (0°C).

Excessive recirculation or insufficient ventilation air, which results in inadequate dilution of combustion products generated by the heater, may create hazardous concentration of carbon monoxide, nitrogen dioxide, and other combustion products in the heated space.

If gas fork trucks or other fossil fuel powered equipment are utilized in the conditioned area, additional ventilation requirements for the facility must be addressed separately.

The heater inlet shall be located in accordance with applicable building code provisions for ventilation air.

Field constructed intake accessories should be properly designed to minimize the entry of snow and rain.

All ventilation air to the heater shall be ducted directly from the outdoors.

If in doubt regarding the application, consult the heater manufacturer.

ETL labeled recirculation heaters must be equipped with a control system and an air measuring station provided by the heater manufacturer and installed on the return air damper or duct.





# Applied Air

4830 Transport Drive, Dallas, TX 75247  
Phone: 214-638-6010 Fax: 214-905-0806  
[www.appliedair.com](http://www.appliedair.com)