

KIC Air Curtains Technical Guide



FOR WIND STOPPING, INSECT CONTROL, AND ENVIRONMENTAL SEPARATION IN COMMERCIAL AND INDUSTRIAL APPLICATIONS



TABLE OF CONTENTS

Introduction2
Model Description2
Selection3
Performance4-7
Dimensions8-11
Electrical12-14
Specifications14-15
Schedule15

Introduction

King has long been a leader in providing innovative solutions for difficult HVAC problems. King KIC Air Curtains can offer protection against cold or hot outside air, outside wind, airborne insects, and airborne particles and contaminants. This technical guide will help you size, select and specify the proper KIC model to satisfy your project's door protection requirements.

Model Description

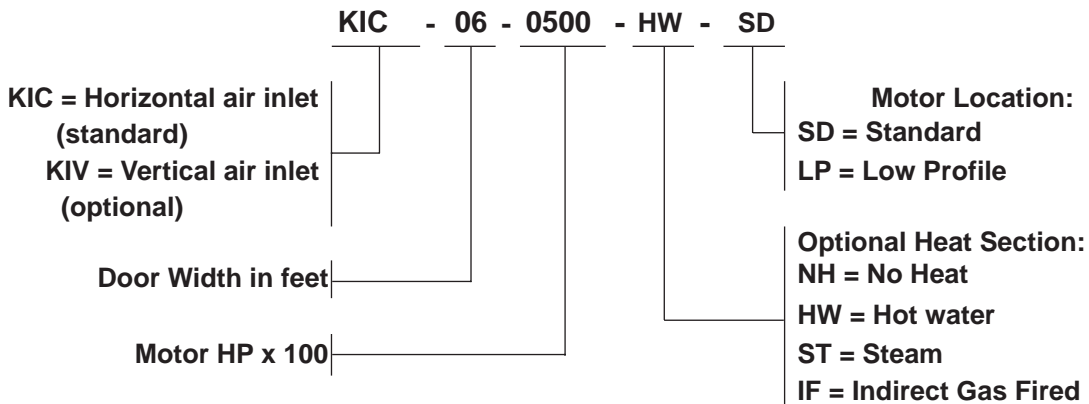

SELECTION

Selection Procedure and Example

Given:

- Door width and door height in feet.
- Design wind velocity in mph.
- If applicable, type of optional heating source: steam coil, hot water coil, indirect fired gas furnace.
- Electrical service characteristics in volts/phase/hertz.

Procedure:

1. Select KIC model size and airflow in cfm from Selection Table below. In many instances, more than one airflow selection will be applicable.
2. Determine the external static pressure requirement as the sum of the static pressure losses of any optional accessories, including filters, steam coil or hot water coil from page 5, or indirect-fired gas furnace from page 6.
3. Using the CFM of step 1 and the external static pressure calculated in Step 2, look up the required motor horsepower from the Fan Performance table on page 7.
4. Referring to the drawing on page 8, choose whether the standard or low profile motor location is desired.

5. Construct the model number using the description shown at the bottom of page 2.

Example:

Given:

- Door width = 14 feet; Door height = 15 feet.
- Design velocity = 9 mph.
- Steam heat with 5 psig pressure.
- Electrical Service = 230volt/3 phase/60 Hz.

Procedure:

1. From Selection Table, the proper selection is a size 14 air curtain with airflow of 19,188 cfm, suitable for door heights of 12 to 17 feet in an 8-10 mph wind.
2. From Steam and Hot Water coil data table on page 5, Coil static pressure drop = 0.52 inches w.c.
3. From Motor HP table on page 7 for a KIC-14 delivering 19,188 cfm with an external static pressure drop of 0.52 inches w.c.: Two each 7.5 HP motors are required.
4. The standard motor location is chosen.
5. The full model number is thus:
KIC - 14 – 1500 – ST – SD.

Selection Table

Size	Airflow Rate (CFM)	Door Height in Feet at 8-10 mph wind	Door Height in Feet at 12-15 mph wind
04	2,775	Under 10	Under 10
	3,177	10-11	
	3,496	12-17	10-11
	4,002		12-17
	4,405		12-17
5,043	18-20	12-17	
05	4,208	Under 12	Under 10
	4,631		10-11
	5,301	12-17	12-17
	5,835		12-17
	6,679		12-17
7,919	18-20	18-20	
06	4,347	Under 10	Under 10
	4,784		10-11
	5,477	10-17	10-11
	6,028		12-17
	6,900		12-17
8,181	18-20	18-20	
9,365		18-20	
07	5,610	Under 10	Under 10
	6,422		10-11
	7,069	10-17	12-17
	8,091		12-17
	9,594		12-17
10,982	18-20	18-20	
12,087		18-20	
08	6,354	Under 10	Under 10
	6,993		10-11
	8,005	10-17	12-17
	9,491		12-17
	10,864		12-17
11,958	18-20	18-20	
09	8,164	Under 12	Under 10
	9,346		10-11
	11,080	12-17	12-17
	12,684		12-17
	13,961		12-17
10	9,123	Under 12	Under 10
	10,816		10-11
	12,381	12-20	12-17
	13,628		18-20
	15,600		18-20
12	9,568	Under 10	Under 10
	10,954	10-11	
	12,056	12-17	10-11
	13,800		12-17
	16,362		12-17
18,730	18-20	18-20	
14	12,844	Under 12	Under 10
	14,138		10-11
	16,182	12-17	12-17
	19,188		12-17
	21,964		12-17
24,174	18-20	18-20	
16	12,708	Under 10	Under 10
	13,986		10-11
	16,010	10-17	12-17
	18,982		12-17
	21,728		12-17
23,916	17-20	18-20	

PERFORMANCE

AMCA Certified Ratings

Size	Model	Airflow Rate (CFM)	Outlet Velocity (FPM)	Power Rating (watts)	Outlet Velocity Uniformity (%)
04	04-0050	2,775	1,930	537	94.4
	04-0075	3,177	2,210	762	94.4
	04-0100	3,496	2,432	989	94.4
	04-0150	4,002	2,784	1,472	94.4
	04-0200	4,405	3,064	1,860	94.4
	04-0300	5,043	3,508	2,746	94.4
05	05-0075	4,208	2,376	762	90.0
	05-0100	4,631	2,615	989	90.0
	05-0150	5,301	2,994	1,472	90.0
	05-0200	5,835	3,295	1,860	90.0
	05-0300	6,679	3,772	2,746	90.0
	05-0500	7,919	4,472	4,571	90.0
06	06-0075	4,347	2,066	762	91.4
	06-0100	4,784	2,274	989	91.4
	06-0150	5,477	2,603	1,472	91.4
	06-0200	6,028	2,865	1,860	91.4
	06-0300	6,900	3,279	2,746	91.4
	06-0500	8,181	3,888	4,571	91.4
07	07-0100	5,610	2,355	989	90.0
	07-0150	6,422	2,696	1,472	90.0
	07-0200	7,069	2,968	1,860	90.0
	07-0300	8,091	3,397	2,746	90.0
	07-0500	9,594	4,028	4,571	90.0
	07-0750	10,982	4,611	6,749	90.0
08	07-1000	12,087	5,074	8,715	90.0
	08-0150	6,354	2,270	1,472	91.4
	08-0200	6,993	2,499	1,860	91.4
	08-0300	8,005	2,860	2,746	91.4
	08-0500	9,491	3,391	4,571	91.4
	08-0750	10,864	3,882	6,749	91.4
08-1000	11,958	4,273	8,715	91.4	

Size	Model	Airflow Rate (CFM)	Outlet Velocity (FPM)	Power Rating (watts)	Outlet Velocity Uniformity (%)
09	09-0200	8,164	2,728	1,860	90.0
	09-0300	9,346	3,123	2,746	90.0
	09-0500	11,080	3,702	4,571	90.0
	09-0750	12,684	4,238	6,749	90.0
	09-1000	13,961	4,664	8,715	90.0
	10	10-0300	9,123	2,654	2,746
10-0500		10,816	3,146	4,571	91.4
10-0750		12,381	3,602	6,749	91.4
10-1000		13,628	3,965	8,715	91.4
10-1500		15,600	4,538	12,440	91.4
12		12-0200	9,568	2,274	1,860
	12-0300	10,954	2,603	2,746	91.4
	12-0500	12,056	2,865	4,571	91.4
	12-0750	13,800	3,279	6,749	91.4
	12-1000	16,362	3,888	8,715	91.4
	12-1500	18,730	4,451	12,440	91.4
14	14-0300	12,844	2,696	2,944	90.0
	14-0400	14,138	2,968	3,720	90.0
	14-0600	16,182	3,397	5,492	90.0
	14-1000	19,188	4,028	9,142	90.0
	14-1500	21,964	4,611	13,498	90.0
	14-2000	24,174	5,074	17,430	90.0
16	16-0300	12,708	2,270	2,944	91.4
	16-0400	13,986	2,499	3,720	91.4
	16-0600	16,010	2,860	5,492	91.4
	16-1000	18,982	3,391	9,142	91.4
	16-1500	21,728	3,882	13,498	91.4
	16-2000	23,916	4,273	17,430	91.4

Velocity Projection (model KIC-6)

Velocity (FPM)	Distance from nozzle (inches)
6070	4
2765	36
1685	120
1375	204

NOTES:

1. The AMCA Certified Ratings Seal applies to airflow rate, average outlet velocity, outlet velocity uniformity, velocity projection and power rating at free delivery only.
2. The AMCA Certified Ratings data shown above applies only to base (unheated) KIC and KIV units at free delivery (External static pressure = 0.0" inches W.C.).
3. Performance data at all other operating conditions obtained from the correction factors shown herein are only an approximation and shall not be considered as part of the AMCA Certified Ratings.

PERFORMANCE

Steam and Hot Water Coils

Size	CFM	Steam Coil *		Hot Water Coil **		Static Pressure Loss (Inches w.c.)
		Heat Transfer (MBH)	Delta T (Degrees F)	Heat Transfer (MBH)	Delta T (Degrees F)	
04	2,775	179	59	123	41	0.13
	3,177	194	56	135	39	0.17
	3,496	204	53	143	37	0.20
	4,002	220	50	157	36	0.26
	4,405	231	48	167	34	0.31
	5,043	248	45	181	33	0.39
05	4,208	250	54	192	42	0.14
	4,631	264	52	204	40	0.16
	5,301	283	49	223	38	0.21
	5,835	298	46	237	37	0.25
	6,679	319	43	259	35	0.31
	7,919	347	40	288	33	0.42
06	4,347	276	58	196	41	0.15
	4,784	291	56	209	40	0.17
	5,477	314	52	228	38	0.22
	6,028	330	50	242	37	0.26
	6,900	355	47	264	35	0.33
	8,181	387	43	294	33	0.45
	9,365	413	40	319	31	0.57
07	5,610	337	55	244	40	0.18
	6,422	363	52	267	38	0.23
	7,069	382	49	283	37	0.27
	8,091	410	46	309	35	0.35
	9,594	447	42	343	32	0.47
	10,982	477	39	372	31	0.60
	12,087	500	38	394	30	0.71
08	6,354	390	56	284	41	0.17
	6,993	411	54	302	39	0.20
	8,005	442	50	329	37	0.25
	9,491	483	46	366	35	0.34
	10,864	518	43	398	33	0.44
	11,958	543	41	422	32	0.52
09	8,164	461	51	343	38	0.23
	9,346	496	48	374	36	0.30
	11,080	541	44	415	34	0.40
	12,684	579	41	449	32	0.51
	13,961	606	39	471	31	0.60
10	9,123	523	52	390	39	0.22
	10,816	573	48	434	37	0.30
	12,381	614	45	465	34	0.38
	13,628	645	43	494	33	0.45
	15,600	687	40	529	31	0.57
12	9,568	567	54	407	39	0.19
	10,954	610	51	444	37	0.25
	12,056	642	48	472	36	0.29
	13,800	688	45	514	34	0.37
	16,362	749	42	571	32	0.50
	18,730	800	39	619	30	0.64
14	12,844	708	50	521	37	0.26
	14,138	745	48	554	36	0.30
	16,182	798	45	603	34	0.39
	19,188	869	41	669	32	0.52
	21,964	927	38	725	30	0.66
	24,174	970	36	768	29	0.79
16	12,708	763	55	557	40	0.18
	13,986	805	52	592	39	0.22
	16,010	865	49	646	37	0.28
	18,982	945	45	718	34	0.37
	21,728	1,011	42	780	33	0.48
	23,916	1,060	40	827	31	0.56

*Steam coil performance based on 2 row, 6 fpi coil at 5 psi and 60 degree EAT.

**HW coil performance based on 2 row, 6 fpi coil at 200 EWT/180 LWT and 60 degree EAT.

For steam or HW coil performance at other conditions, consult factory.

PERFORMANCE

Indirect Fired Heaters

Size	CFM	Heater Size	#of Heaters	Output, MBH	Delta T (degrees F)	Static Pressure loss (inches w.c.)
04	2,776	QVED-200	1	160	53	0.28
	3,177				46	0.35
	3,496				42	0.43
	4,002				37	0.53
	4,405				33	0.69
5,043	29	0.90				
05	4,208	QVED-350	1	280	61	0.20
	4,631				56	0.28
	5,301				49	0.35
	5,835				44	0.41
	6,679				39	0.53
7,919	33	0.78				
06	4,347	QVED-350	1	280	59	0.22
	4,784				54	0.30
	5,477				47	0.38
	6,028				43	0.45
	6,900				37	0.60
8,183	32	0.80				
9,365	28	1.05				
07	5,610	QVED-400	1	320	53	0.30
	6,422				46	0.39
	7,069				42	0.48
	8,091				36	0.61
	9,594				31	0.89
10,982	27	1.13				
08	6,634	QVED-250	2	400	56	0.27
	6,993				53	0.29
	8,405				44	0.39
	9,491				39	0.50
	10,864				34	0.65
09	8,164	QVED-300	2	480	54	0.29
	9,346				47	0.35
	11,080				40	0.50
	12,684				35	0.64
	13,961				32	0.80
10	9,123	QVED-350	2	560	57	0.28
	10,816				48	0.36
	12,381				42	0.49
	13,628				38	0.58
	15,600				33	0.72
12	9,568	QVED-400	2	640	62	0.20
	10,954				54	0.29
	12,056				49	0.34
	13,800				43	0.45
	16,362				36	0.62
18,730	31	0.81				
14	12,844	QVED-300	3	720	52	0.29
	14,138				47	0.38
	16,182				41	0.46
	19,188				35	0.64
	21,964				30	0.86
24,174	27	1.10				
16	12,708	QVED-350	3	840	61	0.22
	13,986				55	0.28
	16,018				48	0.33
	18,982				41	0.49
	21,728				36	0.61
23,916	32	0.73				

PERFORMANCE

Motor HP

Size	CFM	Motor HP at External Static Pressure (Inches W.C.)													
		0.00	0.20	0.25	0.30	0.40	0.50	0.60	0.70	0.75	0.80	0.90	1.00	1.25	1.50
04	2,775	0.50	0.75	0.75	0.75										
	3,177	0.75	1.0	1.0	1.0										
	3,496	1.0	1.5	1.5	1.5	1.5	1.5	1.5	1.5	1.5					
	4,002	1.5	2.0	2.0	2.0	2.0	2.0	2.0	2.0	3.0	3.0				
	4,405	2.0	3.0	3.0	3.0	3.0	3.0	3.0	3.0	3.0	3.0	3.0	3.0		
	5,043	3.0	3.0	3.0	5.0	5.0	5.0	5.0	5.0	5.0	5.0	5.0	5.0	5.0	5.0
05	4,208	0.75	1.0	1.5	1.5										
	4,631	1.0	1.5	1.5	1.5	1.5									
	5,301	1.5	2.0	2.0	2.0	2.0	3.0								
	5,835	2.0	3.0	3.0	3.0	3.0	3.0	3.0							
	6,679	3.0	5.0	5.0	5.0	5.0	5.0	5.0	5.0	5.0	5.0	5.0			
	7,919	5.0	7.5	7.5	7.5	7.5	7.5	7.5	7.5	7.5	7.5	7.5	7.5	7.5	7.5
06	4,347	0.75	1.0	1.5	1.5	1.5									
	4,784	1.0	1.5	1.5	1.5	2.0	2.0								
	5,477	1.5	2.0	2.0	2.0	2.0	3.0	3.0	3.0						
	6,028	2.0	3.0	3.0	3.0	3.0	3.0	3.0	3.0	5.0	5.0				
	6,900	3.0	5.0	5.0	5.0	5.0	5.0	5.0	5.0	5.0	5.0	5.0			
	8,181	5.0	5.0	7.5	7.5	7.5	7.5	7.5	7.5	7.5	7.5	7.5	7.5	7.5	10.0
	9,365	7.5	10.0	10.0	10.0	10.0	10.0	10.0	10.0	10.0	10.0	10.0	10.0	10.0	10.0
07	5,610	1.0	1.5	1.5	1.5										
	6,422	1.5	2.0	2.0	2.0	3.0									
	7,069	2.0	3.0	3.0	3.0	3.0									
	8,091	3.0	5.0	5.0	5.0	5.0	5.0	5.0							
	9,594	5.0	7.5	7.5	7.5	7.5	7.5	7.5	7.5	7.5	7.5	7.5	7.5		
	10,982	7.5	10.0	10.0	10.0	10.0	10.0	10.0	10.0	10.0	10.0	10.0	10.0	15.0	
	12,087	10.0	15.0	15.0	15.0	15.0	15.0	15.0	15.0	15.0	15.0	15.0	15.0	15.0	15.0
08	6,354	1.5	2.0	2.0	2.0	2.0	3.0	3.0							
	6,993	2.0	3.0	3.0	3.0	3.0	3.0	3.0	5.0	5.0					
	8,005	3.0	5.0	5.0	5.0	5.0	5.0	5.0	5.0	5.0	5.0				
	9,491	5.0	5.0	7.5	7.5	7.5	7.5	7.5	7.5	7.5	7.5	7.5	7.5		
	10,864	7.5	7.5	7.5	7.5	10.0	10.0	10.0	10.0	10.0	10.0	10.0	10.0	10.0	15.0
	11,958	10.0	10.0	10.0	10.0	10.0	15.0	15.0	15.0	15.0	15.0	15.0	15.0	15.0	15.0
09	8,164	2.0	3.0	3.0	3.0	3.0	3.0								
	9,346	3.0	5.0	5.0	5.0	5.0	5.0	5.0							
	11,080	5.0	7.5	7.5	7.5	7.5	7.5	7.5	7.5	7.5	7.5	7.5			
	12,684	7.5	10.0	10.0	10.0	10.0	10.0	10.0	10.0	10.0	10.0	10.0	10.0		
	13,961	10.0	15.0	15.0	15.0	15.0	15.0	15.0	15.0	15.0	15.0	15.0	15.0	15.0	
10	9,123	3.0	5.0	5.0	5.0	5.0	5.0	5.0							
	10,816	5.0	7.5	7.5	7.5	7.5	7.5	7.5	7.5	7.5	7.5				
	12,381	7.5	10.0	10.0	10.0	10.0	10.0	10.0	10.0	10.0	10.0	15.0			
	13,628	10.0	10.0	15.0	15.0	15.0	15.0	15.0	15.0	15.0	15.0	15.0	15.0	15.0	
	15,600	15.0	15.0	15.0	20.0	20.0	20.0	20.0	20.0	20.0	20.0	20.0	20.0	20.0	20.0
12	9,568	2.0	3.0	3.0	3.0	3.0	3.0								
	10,954	3.0	5.0	5.0	5.0	5.0	5.0	5.0	5.0	5.0					
	12,056	5.0	5.0	5.0	7.5	7.5	7.5	7.5	7.5	7.5	7.5	7.5			
	13,800	7.5	7.5	7.5	7.5	10.0	10.0	10.0	10.0	10.0	10.0	10.0	10.0		
	16,362	10.0	15.0	15.0	15.0	15.0	15.0	15.0	15.0	15.0	15.0	15.0	15.0	15.0	20.0
	18,730	15.0	20.0	20.0	20.0	20.0	20.0	20.0	20.0	20.0	20.0	20.0	20.0	20.0	25.0
14	12,844	(2) 1.5	(2) 2.0	(2) 2.0	(2) 2.0	(2) 3.0									
	14,138	(2) 2.0	(2) 3.0	(2) 3.0	(2) 3.0	(2) 3.0									
	16,182	(2) 3.0	(2) 5.0	(2) 5.0	(2) 5.0	(2) 5.0	(2) 5.0	(2) 5.0	(2) 5.0						
	19,188	(2) 5.0	(2) 7.5	(2) 7.5	(2) 7.5	(2) 7.5	(2) 7.5	(2) 7.5	(2) 7.5	(2) 7.5	(2) 7.5	(2) 7.5	(2) 7.5		
	21,964	(2) 7.5	(2) 10.0	(2) 10.0	(2) 10.0	(2) 10.0	(2) 10.0	(2) 10.0	(2) 10.0	(2) 10.0	(2) 10.0	(2) 10.0	(2) 10.0	(2) 15.0	
	24,174	(2) 10.0	(2) 15.0	(2) 15.0	(2) 15.0	(2) 15.0	(2) 15.0	(2) 15.0	(2) 15.0	(2) 15.0	(2) 15.0	(2) 15.0	(2) 15.0	(2) 15.0	
16	12,708	(2) 1.5	(2) 2.0	(2) 2.0	(2) 2.0	(2) 2.0	(2) 3.0								
	13,986	(2) 2.0	(2) 3.0	(2) 3.0	(2) 3.0	(2) 3.0	(2) 3.0	(2) 3.0	(2) 5.0						
	16,010	(2) 3.0	(2) 5.0	(2) 5.0	(2) 5.0	(2) 5.0	(2) 5.0	(2) 5.0	(2) 5.0	(2) 5.0	(2) 5.0	(2) 5.0			
	18,982	(2) 5.0	(2) 5.0	(2) 7.5	(2) 7.5	(2) 7.5	(2) 7.5	(2) 7.5	(2) 7.5	(2) 7.5	(2) 7.5	(2) 7.5	(2) 7.5		
	21,728	(2) 7.5	(2) 7.5	(2) 7.5	(2) 7.5	(2) 10.0	(2) 10.0	(2) 10.0	(2) 10.0	(2) 10.0	(2) 10.0	(2) 10.0	(2) 10.0	(2) 10.0	(2) 15.0
	23,916	(2) 10.0	(2) 10.0	(2) 10.0	(2) 10.0	(2) 10.0	(2) 15.0	(2) 15.0	(2) 15.0	(2) 15.0	(2) 15.0	(2) 15.0	(2) 15.0	(2) 15.0	(2) 15.0

Note: If applicable, add 0.25 inches W.C. for filter static pressure loss.

DIMENSIONS

Air Curtain with Optional Heating Coil

C000617A

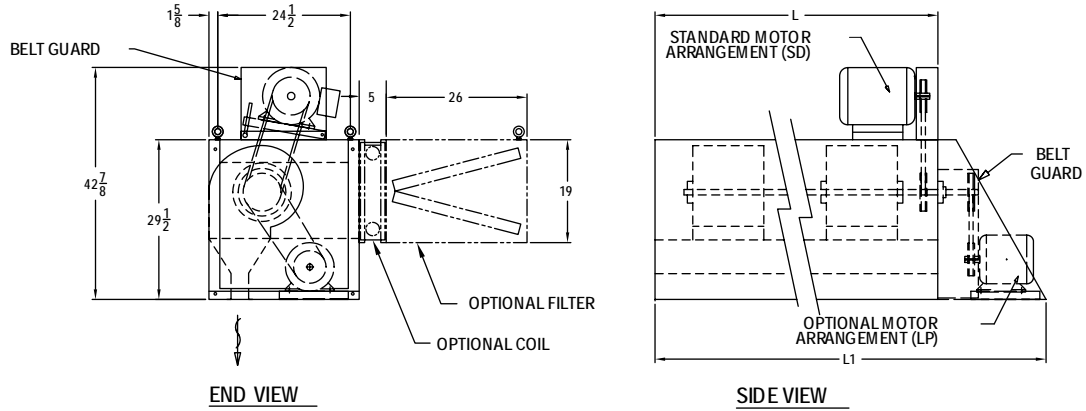

SIZE	L	L1	QTY BLOWERS
04	52	68	2
05	64	80	3
06	76	92	3
07	86	102	4
08	101	117	4
09	108	130	5
10	124	146	5
12	152	174	6
14	172	216	8
16	202	246	8

NOTES: 1. UNIT WITH HORIZONTAL AIR INLET (MODEL KIC) SHOWN;
UNIT WITH TOP VERTICAL AIR INLET (MODEL KIV) OPTIONAL.
2. ALL DIMENSIONS IN INCHES.

Weights

Size	Base Unit	Heating Coil	Filter Section	Gas Heater Section
04	375	67	115	232
05	480	79	135	389
06	530	92	160	389
07	615	102	170	403
08	660	118	190	526
09	750	125	200	624
10	792	141	225	778
12	1056	174	320	806
14	1224	194	340	936
16	1320	226	380	1167

Note: All weights in pounds.

DIMENSIONS

Air Curtain with Single Indirect-Fired Furnace

C000618A

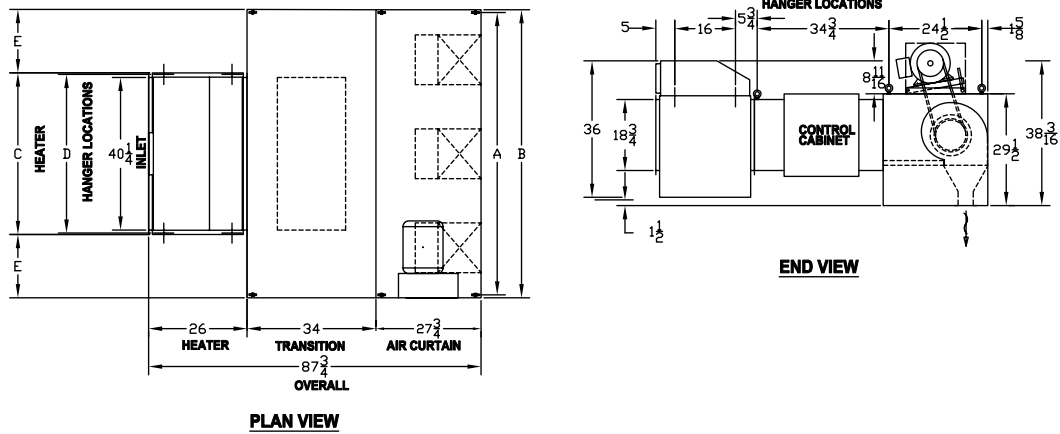

SIZE	HEATER MODEL	QTY	A	B	C	D	E	QTY BLOWERS
04	QVED-200	1	50 $\frac{3}{4}$	52	26 $\frac{1}{8}$	25 $\frac{3}{8}$	13 $\frac{5}{16}$	2
05	QVED-350	1	62 $\frac{3}{4}$	64	42 $\frac{5}{8}$	41 $\frac{7}{8}$	11 $\frac{1}{16}$	3
06	QVED-350	1	74 $\frac{3}{4}$	76	42 $\frac{5}{8}$	41 $\frac{7}{8}$	17 $\frac{1}{16}$	3
07	QVED-400	1	84 $\frac{3}{4}$	86	48 $\frac{1}{8}$	47 $\frac{3}{8}$	19 $\frac{5}{16}$	4

- NOTES: 1. ALL DIMENSIONS IN INCHES.
 2. ABOVE DRAWING ILLUSTRATES NUMBER OF BLOWERS PROVIDED FOR KIC-5;
 REFER TO ABOVE TABLE FOR QUANTITY OF BLOWERS PROVIDED IN OTHER MODELS

DIMENSIONS

Air Curtain with Single Indirect-Fired Furnace

C000619A

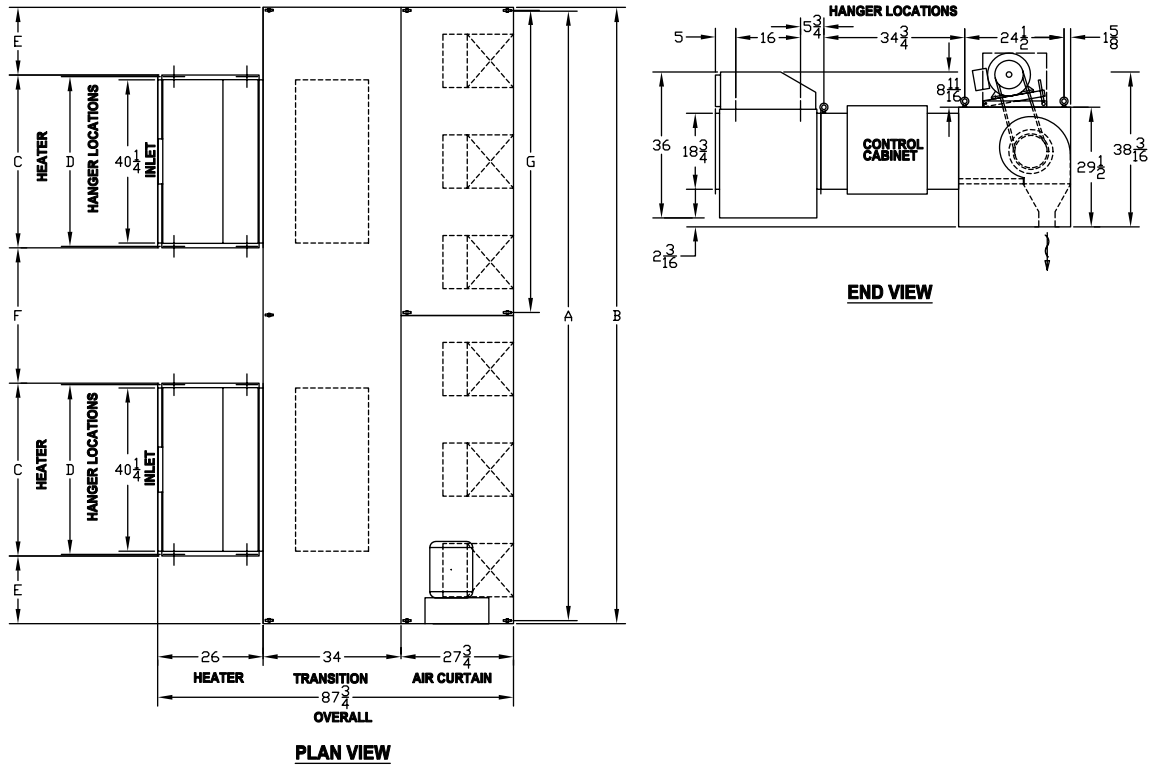

SIZE	HEATER MODEL	QTY	A	B	C	D	E	F	G	QTY BLOWERS
08	QVED-250	2	99 $\frac{3}{4}$	101	31 $\frac{5}{8}$	30 $\frac{7}{8}$	9 $\frac{13}{16}$	19 $\frac{5}{8}$	-	4
09	QVED-300	2	106 $\frac{3}{4}$	108	37 $\frac{1}{8}$	36 $\frac{3}{8}$	8 $\frac{13}{16}$	17 $\frac{5}{8}$	-	5
10	QVED-350	2	122 $\frac{3}{4}$	124	42 $\frac{5}{8}$	41 $\frac{7}{8}$	10 $\frac{1}{16}$	20 $\frac{1}{8}$	-	5
12	QVED-400	2	150 $\frac{3}{4}$	152	48 $\frac{1}{8}$	47 $\frac{3}{8}$	14 $\frac{5}{16}$	28 $\frac{5}{8}$	74 $\frac{3}{4}$	6

NOTES: 1. ALL DIMENSIONS IN INCHES.
 2. ABOVE DRAWING ILLUSTRATES NUMBER OF BLOWERS PROVIDED FOR KIC-12;
 REFER TO ABOVE TABLE FOR QUANTITY OF BLOWERS PROVIDED IN OTHER MODELS.

DIMENSIONS

Air Curtain with Single Indirect-Fired Furnace

C000620

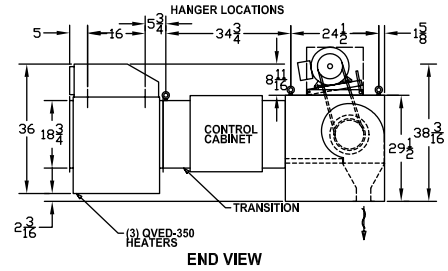
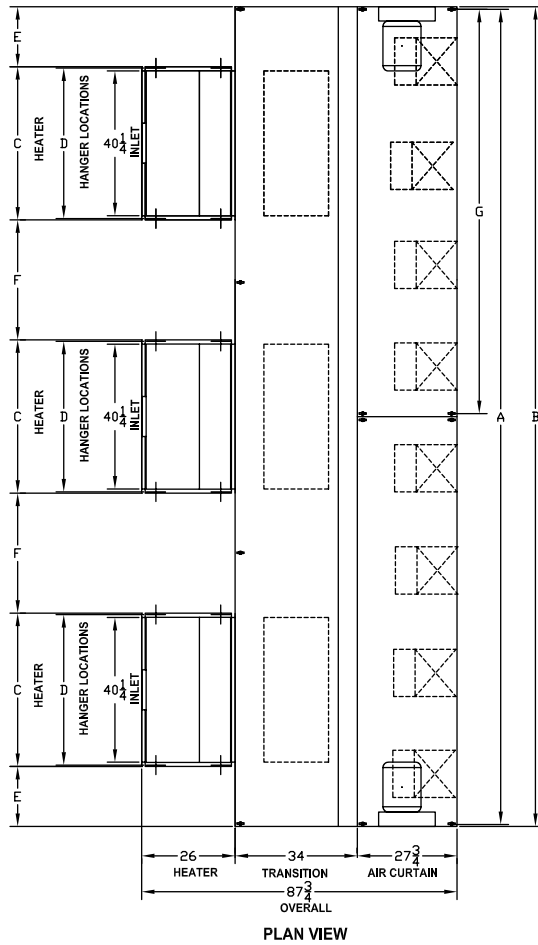

SIZE	HEATER MODEL	QTY	A	B	C	D	E	F	G	QTY BLOWERS
14	QVED-300	3	170 ³ / ₄	172	37 ¹ / ₈	36 ³ / ₈	10 ⁹ / ₁₆	20 ⁷ / ₈	84 ³ / ₄	8
16	QVED-350	3	200 ³ / ₄	202	42 ⁵ / ₈	41 ⁷ / ₈	12 ¹ / ₁₆	25 ¹ / ₈	99 ³ / ₄	8

NOTE: ALL DIMENSIONS IN INCHES.

ELECTRICAL

Wiring Diagram

C000623

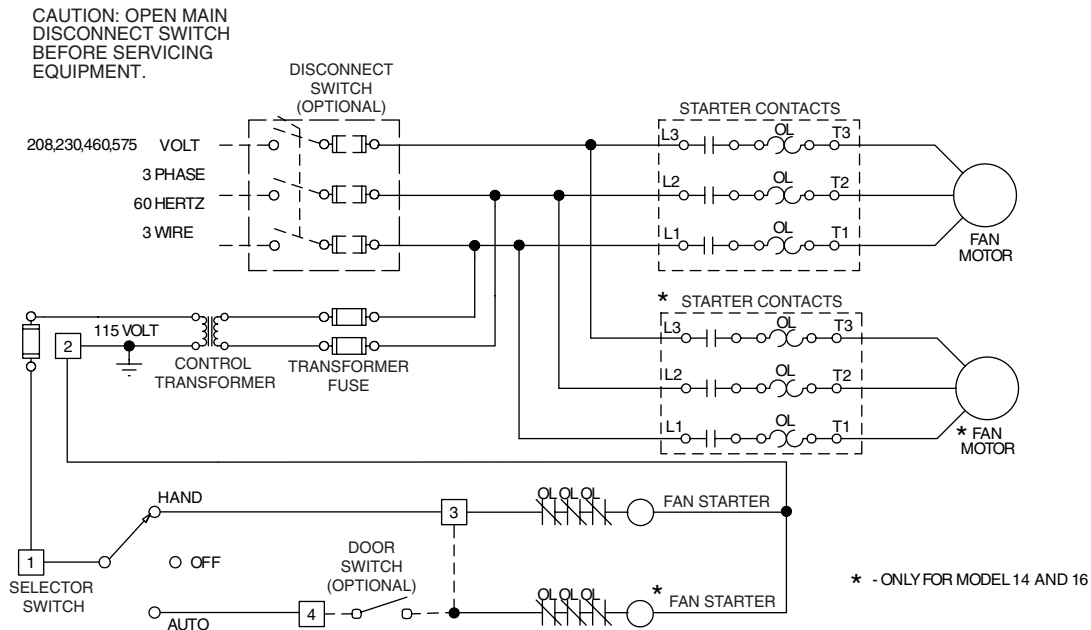

Controls

KIC Air Curtains without optional gas heating are shipped as standard without controls. Motor(s) for such units are mounted on adjustable bases with leads for easy field connections.

A factory-wired control panel is available as an option, complete with NEMA 1 enclosure, magnetic motor starter, overload relay heaters, disconnect switch, 120-volt transformer, terminal strip, and a Hand-Off-Auto switch.

For automatic control with the Hand-Off-Auto switch, two additional options are available: a room thermostat or a door switch. Each of these options must be mounted and wired by others. In the case of a door switch, the air curtain would be wired so that it runs when the door is open.

The Hand-Off-Auto switch is mounted on the face of the control panel. When in the "Hand" position, the air curtain runs regardless of the position of the door switch or room thermostat. When in the "Automatic" position, the air curtain will cycle on and off at the control of the door switch or room thermostat.

ELECTRICAL

Wiring Diagram for Unit Gas Furnaces

C000622

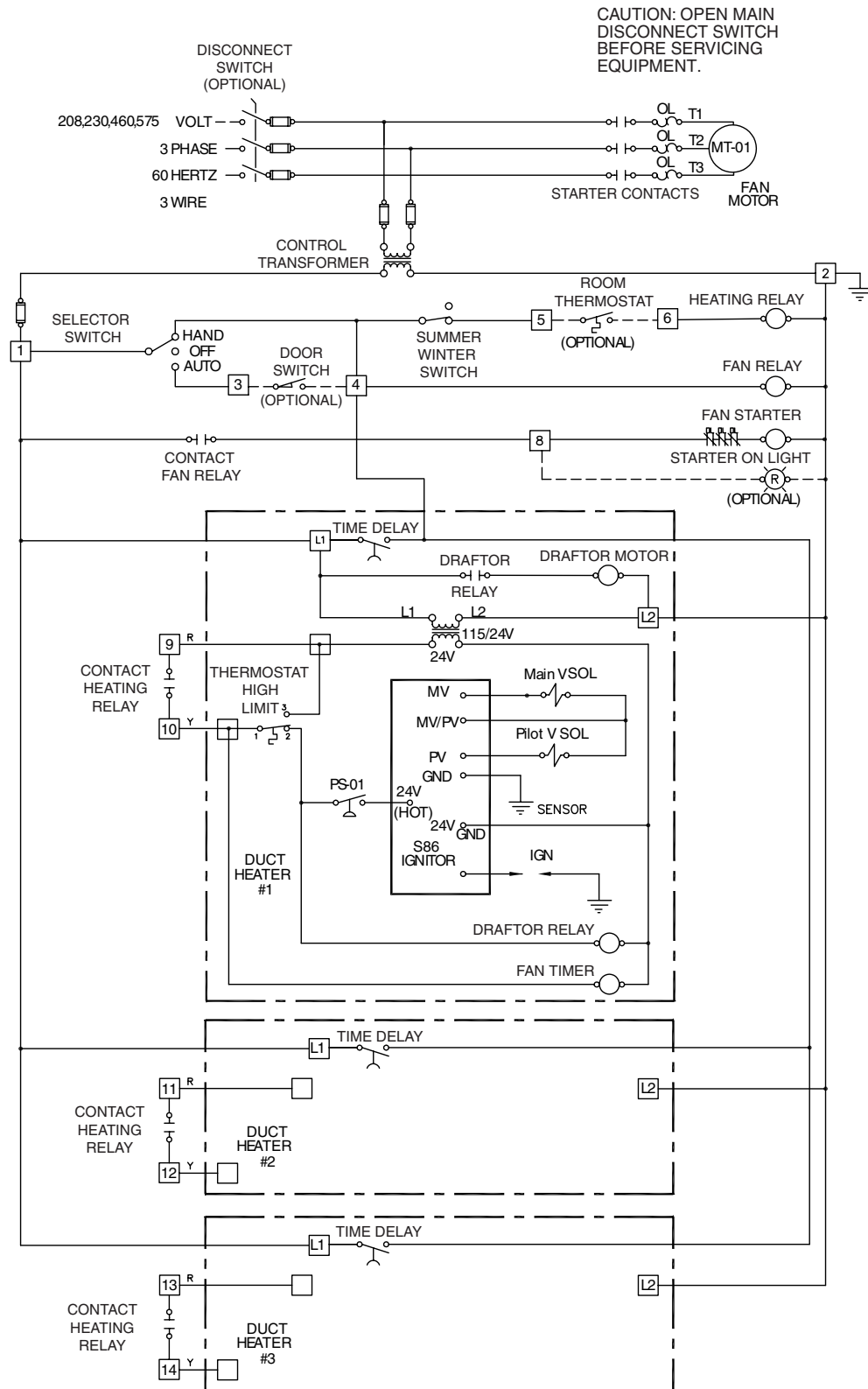

ELECTRICAL

Amp Draw Table

ITEM	SOURCE	ELECTRICAL SERVICE	MOTOR AMPS AT GIVEN MOTOR HORSEPOWER											
			1/2	3/4	1	1 1/2	2	3	5	7 1/2	10	15	20	25
A	Blower Motor	208V 3 Ph	2.4	3.5	4.6	6.6	7.5	10.6	16.7	24.2	30.8	46.2	59.4	74.8
		230V 3 Ph	2.2	3.2	4.2	6.0	6.8	9.6	15.2	22.0	28.0	42.0	54.0	68.0
		460V 3 Ph	1.1	1.6	2.1	3.0	3.4	4.8	7.6	11.0	14.0	21.0	27.0	34.0
		575V 3 Ph	0.9	1.3	1.7	2.4	2.7	3.9	6.1	9.0	11.0	17.0	22.0	27.0
B	Control Transformer	ELECTRICAL SERVICE	CONTROL CIRCUIT AMPS											
			W/O GAS HEATER(S)						WITH GAS HEATER(S)					
		208V 3 Ph	0.5						7.2					
		230V 3 Ph	0.4						6.5					
		460V 3 Ph	0.2						3.3					
	575V 3 Ph	0.2						2.6						

NOTES:

1. Above motor amps are based on 2002 edition of NEC.
2. Control circuit amps are based on standard controls.

Steps to size optional disconnect switch:

1. Using the required blower motor HP and the given electrical service, look up the blower motor amp draw from Item A in the above chart.
2. Look up the control circuit amps for the unit gas heater configuration from Item B in above chart.
3. Add Blower Motor amps from Step 1 to Control Circuit amps of Step 2, then multiply result by 1.25 to get required size of optional disconnect switch.

Specification

General

Furnish King model KIC air curtain(s) with performance as shown on the schedule. Air curtains shall be suited for blanketing the door widths listed on the schedule, and include a minimum overlap of two inches on both sides of the door to sweep the outer edges of the door opening.

Performance at free airflow delivery shall be certified in accordance with AMCA Standard 211.

Fan and Motor Assembly

Provide belt drive motors so that velocity can be maintained through the use of adjustable sheaves. Baffles in the discharge chamber used to adjust velocity while increasing pressure drop are not acceptable. One motor shall be used for air curtains up to twelve feet long; longer air curtains shall have a maximum of two motors.

Motors are to be mounted outside of the airstream (on top of the casing)(on end for low profile), thus eliminating the need for air diverters. Motors shall be open drip-proof (totally enclosed fan-cooled) type and be easily accessible for maintenance without any disassembly of the air curtains.

Blowers shall be centrifugal forward curved type, complete with housings. Blowers shall be tested in accordance with standards set forth in AMCA Standard 210. Blower wheels and housings are to be constructed of painted cold rolled steel. Wheels are to be statically and dynamically balanced. Blower speeds shall not exceed 1,500 rpm.

Casing

Unit shall be constructed with 14 gauge galvanized steel frame, and have sufficient rigidity such that the deflection across its entire length shall not exceed 1/4 inch. Casings are to be built with 16 gauge, galvanized steel. Casings shall have means of attaching hangers, and be equipped with removable panels for access to bearings, couplings and other internal components.

An inlet screen is to be furnished on front of the unit for direct air intake. Multiple inlet screens on top of the unit shall be provided for the purpose of air recirculation.

SPECIFICATION AND SCHEDULE

Specification, cont.

Plenum/Discharge

Provide a tapered plenum at least ten inches long on the discharge of the blowers. A discharge nozzle at least four inches wide shall be included to distribute the outlet air. The outlet air velocity pattern shall have a uniformity of better than 90% over the entire length of the air curtain. Uniformity from the discharge nozzle shall be accomplished without the use of air diverters. Discharge nozzles shall be field adjustable to plus or minus fifteen degrees with no objects, dampers, or grilles included to add turbulence or create a pressure drop in the airstream.

The unit design shall allow for the addition of heating sections or filters without altering the base unit.

Optional Accessories

A. Provide a factory-wired control panel that includes the following items:

- NEMA 1 enclosure (NEMA 12 enclosure)
- Magnetic motor starter
- Overload relay heaters
- Disconnect switch
- 120 volt transformer
- Terminal strip
- Hand-Off-Auto switch in cover

Control panels to be remote mounted (unit-mounted)(unit-mounted and wired to motor). (Control panel shall be U.L. listed).

B. Provide steam or hot water heating coil constructed of two rows of minimum 0.020 inch thick wall copper tubing mechanically expanded into minimum 0.006 inch thick, full collar aluminum fins spaced at six fins per inch. Coil face velocity shall not exceed 1,200 fpm. Coils are to be rated at 125 psig operating pressure and tested at 400 psig.

C. Provide AGA-certified indirect-fired furnaces of the capacities as indicated on the schedule. Unit shall include a transition section between the furnace outlet and air curtain inlet. The duct furnaces shall include a single stage (two stage) gas valve. The heat exchanger is to be constructed of aluminized steel (409 stainless steel). Provide unit for induced draft fans. Duct furnaces are to be provided with automatic spark ignition. Fuel supply to be natural gas (propane).

D. Filter section with disposable filters.

E. High efficiency motors.

F. Painted galvanized casing.

G. Door switch.

H. On-off room thermostat.

I. Vibration hangers

Schedule

From Example on page 3:

Model No.	Airflow (cfm)	External Static Pressure (inches w.c.)	Motor HP	Steam Pressure (psig)	Heat Transfer, MBTUH	Delta T (Degrees F)	Electrical Volts/phase/HZ	Tag
KIC-14-1500-ST-SD	19,188	0.52	2@7.5	5	869	41	230/3/60	DAC-1



King certifies that the air curtains shown herein are licensed to bear the AMCA seal. The ratings shown are based on tests and procedures performed in accordance with AMCA Publication 211 and comply with the requirements of the AMCA Certified Ratings Program.



4830 Transport Drive, Dallas, TX 75247
Tel. (214) 638-6010 Fax (214) 905-0806
www.ljwing.com