

# INSTALLATION, OPERATION AND MAINTENANCE MANUAL

## AIR CURTAINS

**ATTENTION: READ THIS MANUAL AND ALL LABELS ATTACHED TO THE UNIT CAREFULLY BEFORE ATTEMPTING TO INSTALL, OPERATE OR SERVICE THESE UNITS! CHECK UNIT DATA PLATE FOR ELECTRICAL SPECIFICATIONS AND VERIFY AGREEMENT WITH POINT OF INSTALLATION. RECORD THE UNIT MODEL AND SERIAL No.(s) IN THE SPACE PROVIDED. RETAIN FOR FUTURE REFERENCE.**

Model No. \_\_\_\_\_ Serial No. \_\_\_\_\_

### SAVE THIS MANUAL

#### FOR YOUR SAFETY

The use and storage of gasoline or other flammable vapors and liquids in open containers in the vicinity of this appliance is hazardous.

#### FOR YOUR SAFETY

If you smell gas:

1. Open windows.
2. Don't touch electrical switches.
3. Extinguish any open flame.
4. Immediately contact your gas supplier.

**WARNING: Improper installation, adjustment, alteration, service, or maintenance can cause property damage, injury, or death. Read the installation, operating, and maintenance instruction thoroughly before installing or servicing this equipment.**

#### WARNING

**Install, operate, and maintain unit in accordance with the manufacturer's instructions to avoid exposure to fuel substances, or substances from incomplete combustion, which can cause death or serious illness. The state of California has determined that these substances may cause cancer, birth defects, or other reproductive harm.**

#### INSTALLER'S RESPONSIBILITY

**Installer Please Note:** This equipment has been tested and inspected. It has been shipped free from defects from our factory. However, shipment and installation problems such as loose wires, leaks, or loose fasteners may occur. **It is the installer's responsibility to inspect and correct any problem that may be found.**

ATTENTION: READ CAREFULLY BEFORE ATTEMPTING TO INSTALL, OPERATE OR SERVICE THIS EQUIPMENT. RETAIN FOR FUTURE REFERENCE.

**POST AND MAINTAIN THESE INSTRUCTIONS IN LEGIBLE CONDITION.**



## SECTION I – FORWARD

As in the case with any fine piece of equipment, care must be taken to provide the proper attention to the operation and maintenance detail of this machine.

This manual of instructions has been prepared in order for you to become well-acquainted with those details, and in doing so, you will be able to give your Air Curtain the care and attention which any piece of equipment needs and deserves

### Table of Contents

Section I: Forward and Table of Contents .....	2
Section II: General Information .....	3
Section III: Installation .....	4
Section IV: Pre-Start Up .....	6
Section V: Unit Start Up .....	7
Section VI: Unit Shut Down .....	9
Section VII: Troubleshooting .....	10
Section VIII: Maintenance & Lubrication .....	12
Section IX: Replacement Parts .....	15
Section X: Start-Up Form .....	16

### IMPORTANT NOTICE

The manufacturer assumes no responsibility for loss or damage in transit; therefore, you should protect yourself by following these instructions. Failure to do so is your responsibility.

#### **BILL OF LADING**

Save your bill of lading. It is a contract, and you will need it, provided you have to file a loss or damage claim. Remember, claims are outlawed after nine months.

#### **LOSS IN TRANSIT**

Before you sign for this equipment, check against the bill of lading, and the transportation company's delivery ticket. Make sure that you get the exact total of articles listed. Should the delivery ticket show more or less items than you are offered, then the carrier's agent must mark the difference on your freight bill before you sign.

#### **VISIBLE DAMAGE IN TRANSIT**

If something is damaged, accept the shipment only if the carrier's agent places a notation on your freight bill explaining the nature and extent of damage. Upon inspection of article, make claim to the delivering carrier.

#### **CONCEALED DAMAGE IN TRANSIT**

Sometimes transit damage is not noticed until the goods are unpacked. In such cases, notification to the carrier must be made within fifteen (15) days of receipt of shipment. In such cases, save the packages and packing material, then notify the transportation company at once, and request an inspection. Request that the inspector make out and leave a "concealed" bad order report. The inspector is obliged to give one to you. Insist on it.

#### **DISPOSITION OF DAMAGED ARTICLES**

Never return damaged article to the factory. They are the property of the transportation company when the claim is filed. They will give you disposition instructions.

#### **PACKING**

We comply with the packing requirements of the transportation companies, and your bill of lading proved that everything was in good condition when shipped. That bill of lading contract requires them to deliver in perfect condition.

## SECTION II – GENERAL INFORMATION

### A. Purpose

The purpose of this manual is to present a guide for proper installation, maintenance, and operation of the Air Curtain, and supplement, but not to replace, the services of qualified field service personnel to supervise the initial start-up and adjustment of the unit. Persons without previous experience with large commercial and industrial HVAC equipment should not attempt the initial adjustment and checkout procedure, which is essential before such installations may be considered ready for operation. This manual should be made readily available to all operating personnel as an aid in trouble shooting and proper maintenance. Due to the custom nature of this equipment, not all possibilities are addressed in this manual. The customer or installer can obtain information from the local sales representative or the factory.

### B. Shipping

Base Air Curtain units are shipped completely assembled where shipping limitations allow. Optional filter sections and/or gas fired heating sections are assembled and shipped mounted and wired whenever possible within limitations of shipping and handling. Some optional accessories shipped separately may require field assembly. Any wired accessories, which have been disassembled for separate shipment, require no additional conduit or wire for field reassembly. All wire leads will be tagged for ease of reconnection in the field.

If the Air Curtain and/or accessories cannot be installed immediately, they should be stored in a clean dry environment. If this is not possible, and the Air Curtain must be stored outdoors, it should be protected from the weather with tarpaulins or plastic coverings. Do not assume that simply covering a unit will keep insects, dust, and condensation out of the unit and critical components. Rotate the fans monthly.

Shipments are made F.O.B. Dallas, Texas by truck. The unit is securely strapped, tied, and blocked to prevent shipping damage. All shipments are checked by an inspector before they are accepted by the carrier. Parts that are shipped un-mounted are noted on the bill of lading. These parts, where feasible, are packaged and shipped with the units. Upon receipt of shipment, all units should be checked against the bill of lading to insure all items have been received. All equipment (and any optional accessories) should be checked carefully for physical damage in the presence of the carrier's representative. If parts are missing or damage has occurred, you should request an inspection, and a claim should be filed immediately with the carrier.

Air Curtain units are given a complete operations test and control circuit (if ordered) checkout before shipment. Copies of the wiring diagram and bill of material are included with each unit shipped. If correspondence with the factory is necessary, please provide the unit model and serial number.

### C. Optional Factory Service

Periodic service on any piece of mechanical equipment is necessary for efficient operation. A nationwide service support network is available to provide quick and dependable servicing of HVAC equipment. The factory also offers start-up service, which includes the presence of a service engineer to supervise the initial start-up and adjustment of the equipment and provide instructions for the owner's maintenance personnel in proper operations and maintenance. Consult factory for quotations on periodic or start-up service.

Figure 1

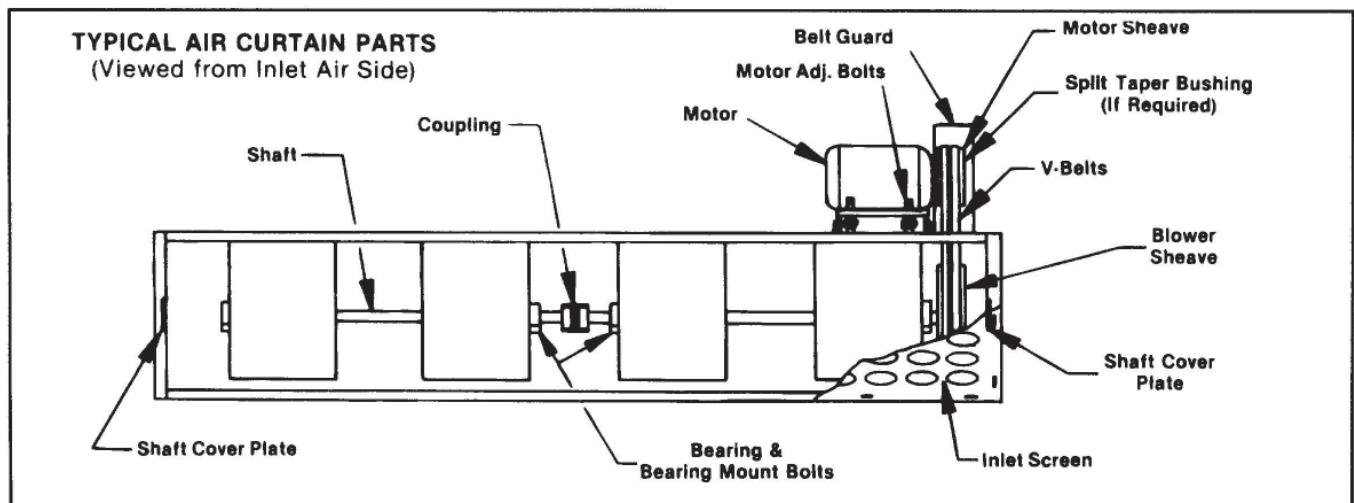

## SECTION III – INSTALLATION

Prior to beginning installation of a unit that has been in storage for weeks or months, the unit and its components should be closely inspected.

### FOR CANADIAN INSTALLATIONS ONLY

1. All installations with gas heaters must conform with local building codes, or in the absence of local codes, with current CAN/CGA-B149-Installation Codes for Gas Burning Appliances and Equipment.
2. All electrical connections must be in accordance with Canadian Electrical Code, Part 1, CSA Standard C22.1

All electrical connections must conform to the current edition of ANSI/NFPA No. 70 National Electrical Code and applicable local codes: in Canada, to the Canadian Electrical Code, Part 1 CSA Standard C22.1. The following recommendations are not intended to supplant any requirement of federal, state, or local codes having jurisdiction. Authorities having jurisdiction should be consulted before installations are made. Local codes may require additional safety controls and/or interlocks.

All installations in airplane hangers must be in accordance with current ANSI/NFPA No. 409. All installations in public garages must be in accordance with current NFPA No 88A and NFPA No. 88B.

**CAUTION: Do not install gas fired heating system in corrosive or flammable atmospheres! Premature failure of, or severe damage to, the unit will result!**

**CAUTION: Gas fired heating system must not be installed in locations where air for combustion would contain chlorinated, halogenated or acidic vapors. If located in such an environment, premature failure of the unit will occur!**

### A. Handling the Equipment

The Air Curtain is designed to be lifted by eye bolts located on the top of the unit. See Figure 2.

Make certain that chains or cables used to lift the Air Curtain are safely hooked through the eyebolts and will not loosen while lifting.

The angle of the chains or cables used for lifting should not exceed 60° from the vertical center line. It may be necessary to use a spreader bar to accomplish this, depending on the length of the chains.

Figure 2

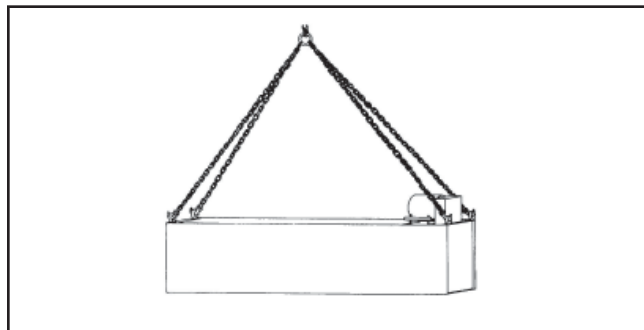

If a forklift is used to raise the Air Curtain, be careful not to scratch the finish, or bend and damage the metal structure of the unit.

**WARNING: Be aware of a weight imbalance due to the weight of the motor(s), and control panel, if mounted.**

### B. Locating the Unit

Prior to locating the unit, authorities having jurisdiction should be consulted before installations are made. Approval permits should be checked against the unit received. **For any Air Curtain with optional gas heating section; refer to furnace manufacturer's IOM manual for specific instructions regarding installation, piping, and venting.**

Locate the unit exactly level. The Air Curtains are designed to be mounted by end flanges and no additional support is required. They may be attached to a wall, suspended from overhead, or supported beneath the end flanges. Brackets or suspension rods (to be supplied by the installer) must be located so that no obstacle lies within the nozzle airstream, throughout its adjustment of 20° either side of vertical. If the nozzle airstream does strike an obstruction, such as top edge of the doorway or a structural beam, its efficiency will be destroyed.

When an Air Curtain must be mounted with its nozzles lower edge above the top of the actual doorway, a 3/8" minimum space must be provided between the wall and the back surface of the unit for every inch in height of the nozzle above the doorway top.

Different types of doors require different mounting methods for the Air Curtain units. See following diagrams for recommendations.

1. STEEL ROLL DOOR

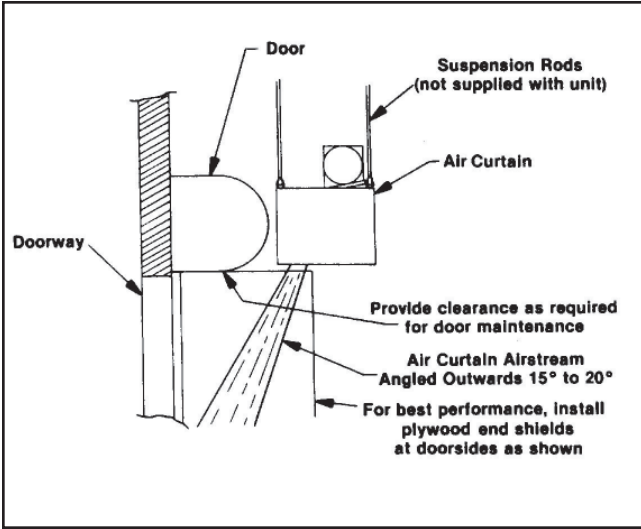

4. "TURN BACK" TRACK DOOR METHOD A

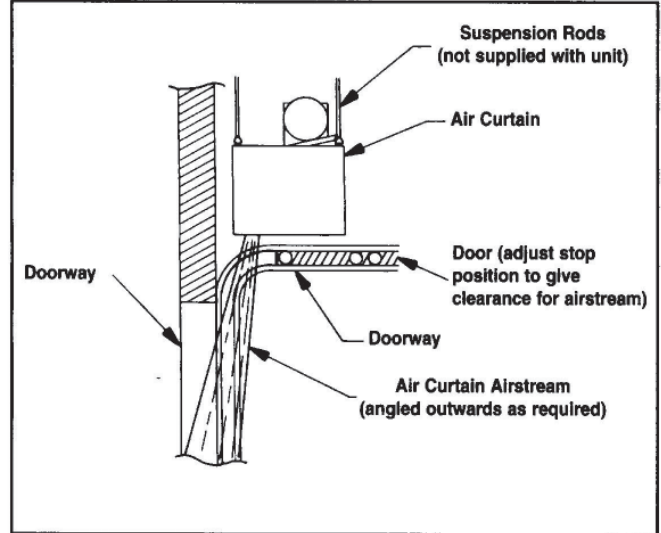

2. HIGH RISE TRACK DOORS

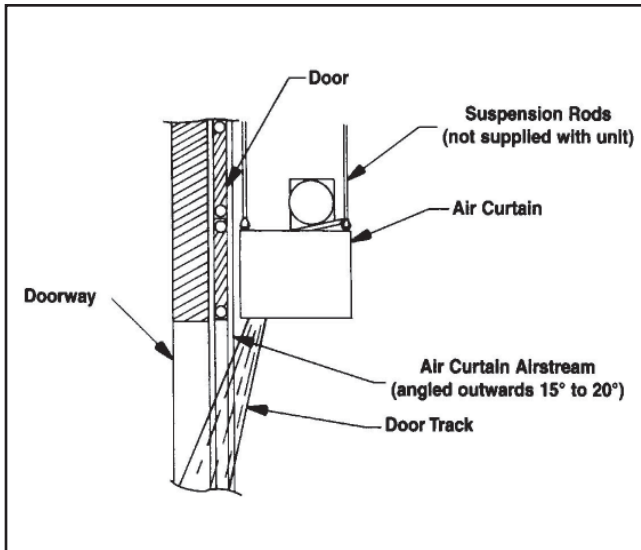

5. "TURN BACK" TRACK DOOR METHOD B

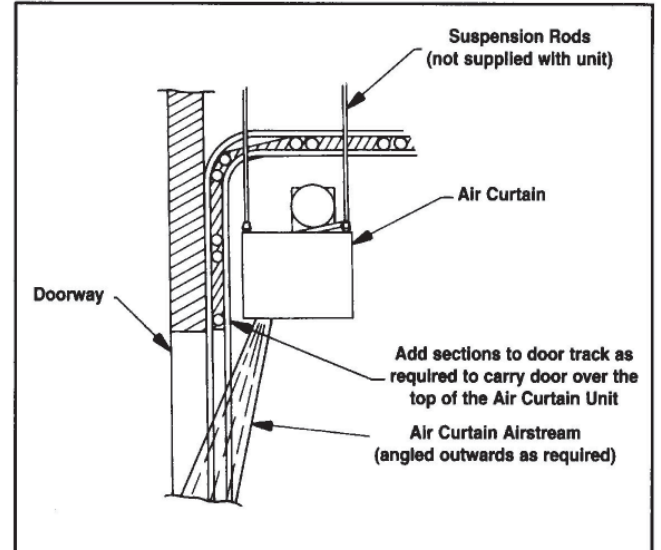

3. SLIDING DOORS

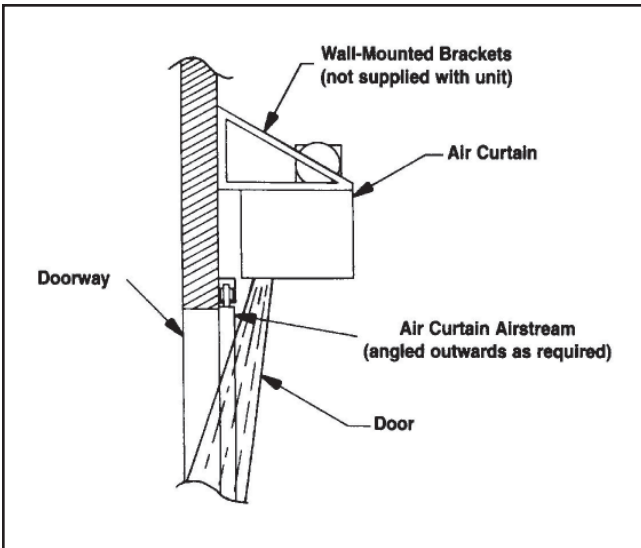

6. STANDARD HINGED DOORS

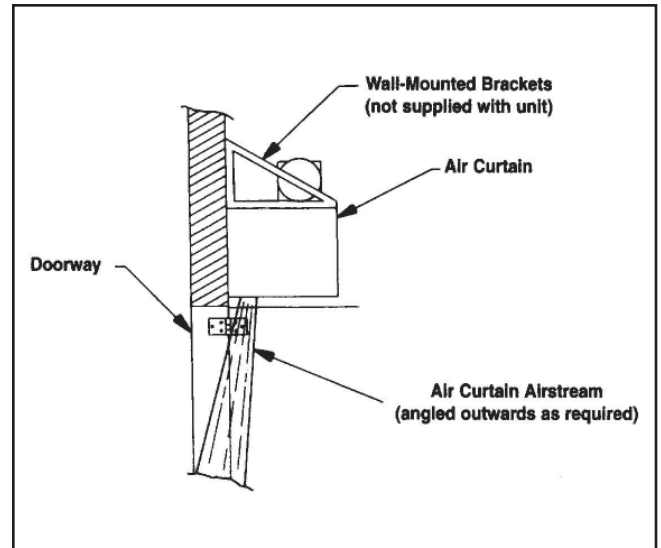

## SECTION IV – PRE START-UP

The following list is submitted in addition to installation requirements and is not intended to supplant regulations or codes having jurisdiction. It is recommended these items be reviewed and completed prior to requesting or initiating equipment start-up.

**Do not attempt start-up without completely reading and understanding this manual. For any Air Curtain with optional gas heating section; refer to furnace manufacturer's IOM manual for specific instructions regarding installation, piping, and venting.**

### A. Owner's Representative

The owner's representative or equipment operator should be present during start-up to receive instructions on care and adjustments of the equipment.

All equipment has been factory tested, adjusted, and inspected to meet conditions set at the time the order was placed. Only minimal adjustments should be required. All information in this manual is typical. All products are semi-custom and changes may occur.

### B. Suggested Tools and Instruments

Volt/Ohm Meter	Thermometer
Tachometer	Ammeter
Manometer (0-10" W.C.)*	Microammeter
Standard Hand Tools	D.C. Volt Meter
Gas Pressure Gauge (0-35lbs.)*	

Note: Items with \* may not be required on units without gas heating section.

### C. Pre Start-Up Inspection

This inspection is extremely important and should be completed with the greatest care given to detail. A good pre start-up inspection will insure against possible unit damage on start-up, and will save valuable analysis time in the event a malfunction should occur on start-up.

1. Check that the physical condition of the unit exterior is acceptable.

2. Check to see that all factory installed temporary pipe covers have been removed.
3. Check supply voltage against unit voltage. If voltage over + 10% of nameplate rating or phase voltage unbalance is over 2%, notify contractor or power company.
4. Check all electrical connections for tightness at all terminals in the main control panel and remote control panel (if applicable).
5. Check that all fuses are installed.
6. If optional steam or hot water coils are supplied, check to see that all piping connections are secure and that face area of coil has not been damaged or blocked.
7. Check blowers, pulley, bearing set screws, and coupling (if applicable) for tightness.
8. Check blower compartment to insure shaft rotates freely and belt tension is correct. **Do not over tighten belts.**
9. Check blower motor to insure that pulleys are secure and motor base is properly adjusted.
10. If optional filter section is supplied, check filters for cleanliness. Make sure throwaway filters are free of moisture. (Note: With blowers operating, wet filters will be sucked into the downstream sections of the unit.)
11. Check all areas for cleanliness.
12. Secure all access doors or panels.

### D. Warranty

Start-up forms are available from the factory. Basic warranty is 12 months from date of shipment without start-up form on file at the factory. With a start-up form, warranty is 12 months from start-up, not to exceed 18 months from date of shipment.

### E. Replacement Parts

Replacement parts must be ordered from the local representative. All warranty parts will be shipped the least expensive way from the factory. Warranty parts must be returned prepaid within 30 days. **Credit will be issued if the part is complete, defective, and returned on time.**

## SECTION V – UNIT START-UP

**Before attempting to start the Air Curtain read and understand the sequence of operation and electrical schematic.**

Make sure all doors and service panels have been closed or replaced.

Turn main disconnect switch off. Check that incoming line voltage matches unit nameplate rating. If voltage is over + 10% of nameplate rating or phase voltage unbalance is over 2%, notify contractor or power company.

Turn main disconnect switch on. Turn Hand-Off-Auto switch to Hand position. Blower motor starts. Turn Hand-Off-Auto switch to Off position. Check blowers for proper rotation.

**NOTE: To change rotation of the blowers, simply interchange any two (2) of the line leads of the motor starter for three (3) phase motors. On single phase motors refer to motor nameplate.**

Turn Hand-Off-Auto switch to Hand position. Check for proper blower rpm. Check that motor amp draw does not exceed nameplate ratings and overloads are set to motor nameplate amps.

**For any Air Curtain with optional gas heating section; refer to furnace manufacturer's IOM manual for specific instructions regarding installation, piping, venting, and burner set up.**

### Adjusting Airflow

Each unit is provided with an adjustable sheave on the blower motor. Each flange of the sheave has a small notch on the O.D. of the flange. This mark is located directly over the keyway on the two adjustable flanges and over only one of the keyways on the non-adjustable (center) flange. To obtain proper adjustments:

1. Loosen setscrews "B" in moving parts of sheave and pull out external key "E". (This key projects a small amount to provide a grip for removing.)
2. Tighten both adjustable flanges to their fully closed position.
3. Locate the file mark over the keyway on the center flange.
4. Open each adjustable flange until its notch is adjacent to the notch on the center flange. Be certain that neither adjustable flange is opened more than one full turn.
5. From the position obtained in Step 4, open each adjustable flange the same number of full or half turns until the desired flange spacing is obtained. **DO NOT OPEN MORE THAN FIVE FULL TURNS FOR "A" BELTS OR SIX FULL TURNS FOR "B" BELTS.**
6. Replace external key "E" and tighten setscrews "B" over key. Wrench Torque: 110 inch/lbs min to 130 inch/lbs max.
7. Put on belts and adjust belt tension. (do not force belts over grooves.) See Maintenance Section for belt installation instructions.
8. Future adjustments should be made by loosening the belt tension and increasing or decreasing the pitch diameter of the sheave by half or full turns as required. Readjust belt tension before starting drive. **Check that motor amp draw does not exceed nameplate ratings and overloads are set to motor nameplate amps.**
9. Two groove sheaves must have both halves adjusted by the same number of turns from the position established in Step 4 to insure the same pitch diameter.
10. Be sure that ALL keys are in place and that all setscrews are torqued properly before starting drive. Check setscrews and belt tension after 24 hours service.

### Adjusting Variable Pitch Key Type Sheave

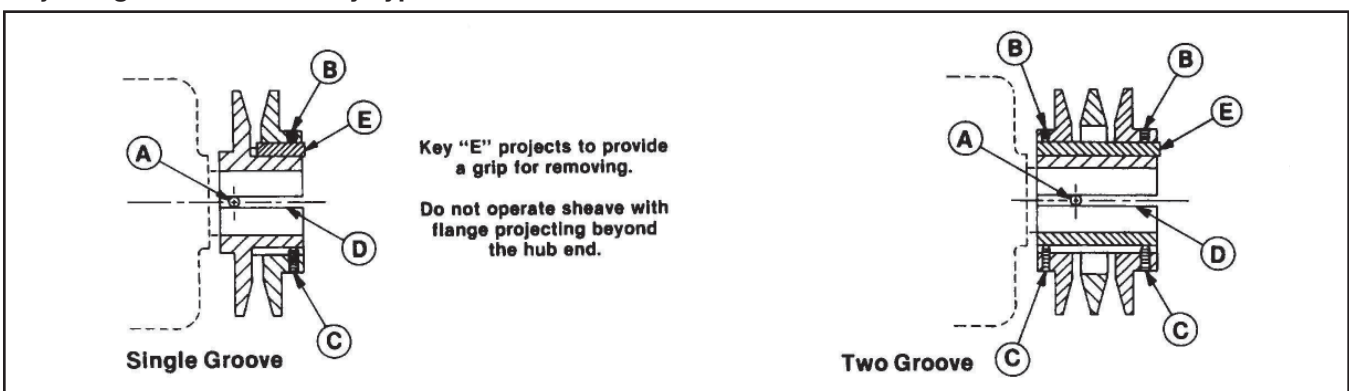

### SHEAVE ALIGNMENT

1. Obtain two straight edges long enough to span the distance between the sheaves.
2. Loosen the set screws on the motor sheave so that the sheave can slide freely on the motor shaft.
3. Hold the two straight edges against the outside of the driven, blower sheave, extending them toward the motor.
4. Slide the motor sheave horizontally on the motor shaft until the straight edges indicate that both sheaves are parallel.

**NOTE:** Motor sheave might be slightly wider than the blower sheave – in this case, the distance between the motor sheave and the straight edge should be the same on both sides of sheave.

### Belt Tension Adjustment

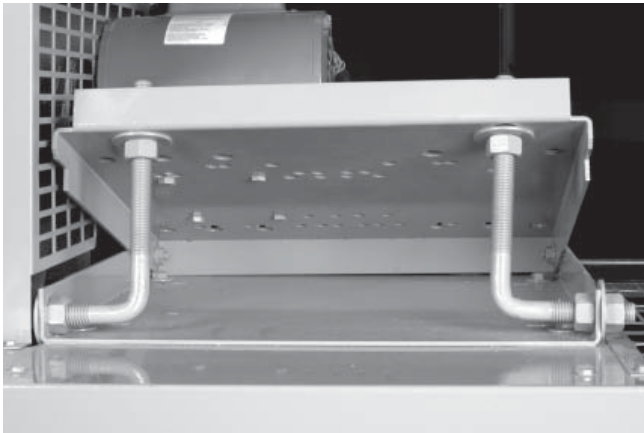

### DEFLECTION BLADE ADJUSTMENT

Under most conditions, the Air Curtain should be adjusted so that on windy days it is set at its maximum outward deflection and on calm days it is angled slightly inward (5 – 15°).

The adjustment of the directional control is accomplished by loosening the two cap screws on each end of the directional control blades. Then the directional control blades can be re-positioned by hand to give the required air deflection to suit the individual application. After the proper air pattern has been achieved, the cap screws can be tightened to lock the blades in place.

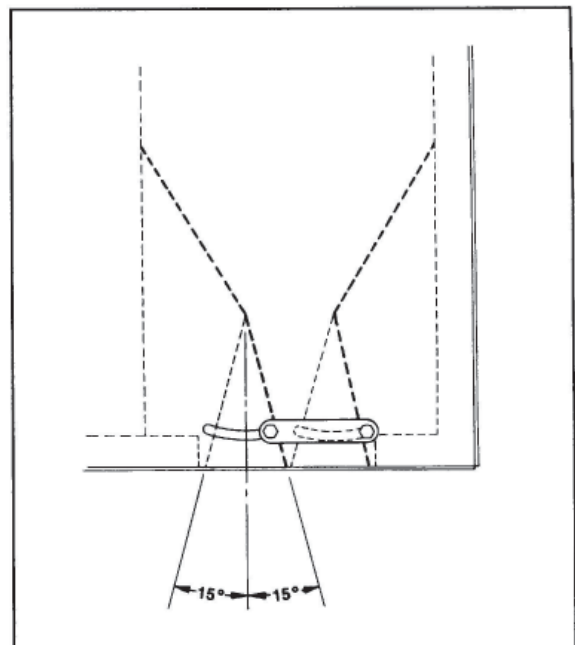



## SECTION VI – UNIT SHUTDOWN

### A. Extended Shutdown

1. Set the “Hand-Off-Auto” switch in the Off position.
2. Close all manual gas valves (if applicable).
3. Open the main electrical disconnect switch.

During any extended down time, all water should be drained from the coil (if applicable). The coil should then be flushed with a glycol solution if the possibility of freezing exists.

Coils **are not** warranted against freezing.

### B. Emergency Shutdown ONLY

1. Open the main electrical disconnect switch.
2. Close all manual gas valves (if applicable).

## SECTION VII – TROUBLESHOOTING

Symptom	Cause	Remedy
A. If blower does not operate	<ol style="list-style-type: none"> <li>1. Low or no voltage</li> <li>2. Fuse(s) blown</li> <li>3. Customer interlock not closed or connected.</li> <li>4. Field installed controls open.</li>   <li>5. Freeze protection tripped.</li>   <li>6. Overload protection on motor starter tripped.</li> <li>7. Belts loose or broken.</li> <li>8. Bearings seized.</li> <li>9. Motor may be burned or incorrectly wired.</li> </ol>	<ol style="list-style-type: none"> <li>1. Check power source</li> <li>2. Check and replace</li> <li>3. Close or connect customer interlock.</li> <li>4. Check field installed controls for proper setting.</li> <li>5. Reset freeze stat. Check for proper setting.</li> <li>6. Push reset button on starter and check amps.</li> <li>7. Turn power off and check belts.</li> <li>8. Check and replace.</li> <li>9. Turn power off and check motor and wiring.</li> </ol>
B. Belts slip (Shiny sheave grooves)	<ol style="list-style-type: none"> <li>1. Not enough tension.</li> <li>2. Overloaded drive</li> </ol>	<ol style="list-style-type: none"> <li>1. Increase tension.</li> <li>2. Redesign drive.</li> </ol>
C. Drive squeals	<ol style="list-style-type: none"> <li>1. Heavy starting load</li> <li>2. Loose belt</li> </ol>	<ol style="list-style-type: none"> <li>1. Increase tension</li> <li>2. Increase tension</li> </ol>
D. Belt(s) turned over	<ol style="list-style-type: none"> <li>1. Broken cord caused by prying on sheave.</li> <li>2. Overloaded drive.</li> <li>3. Impulse loads.</li>   <li>4. Misalignment of pulley shaft.</li> <li>5. Worn sheave grooves.</li> <li>6. Excessive belt tension.</li> </ol>	<ol style="list-style-type: none"> <li>1. Replace set of belts correctly.</li>   <li>2. Redesign drive.</li> <li>3. Use pivoted motor base to apply proper belt tension.</li> <li>4. Realign drive.</li> <li>5. Replace sheaves.</li> <li>6. Check drive design. Check equipment for solid mounting.</li> </ol>
E. Mismatched belts	<ol style="list-style-type: none"> <li>1. New belts installed with old belts.</li>   <li>2. Sheave grooves worn unevenly (gives appearance of mismatched belts).</li> <li>3. Pulley shafts not parallel (gives appearance of mismatched belts).</li> </ol>	<ol style="list-style-type: none"> <li>1. Replace belts in double matched sets only.</li> <li>2. Replace sheaves.</li>   <li>3. Align drives.</li> </ol>

<p>F. Blower operates but system fails to heat air to design temperature.</p>	<ol style="list-style-type: none"> <li>1. Heating relay contacts open.</li> <li>2A. For steam and hot water systems, two position or modulating valve and controller not functioning properly.</li> <li>2B. For gas systems, two position or modulating valve and controller not functioning properly.</li> <li>3. Steam or hot water lines are not open or free flowing.</li> <li>4. Steam pressure or water temperature does not match specification.</li> <li>5. Flow rate for steam, hot water, or gas does not match specification.</li> </ol>	<ol style="list-style-type: none"> <li>1. Check to see that room thermostat is calling for heat.</li> <li>2A. Check and replace.</li> <li>2B. Refer to furnace manufacturer's IOM manual for specific instructions.</li> <li>3. Check all lines and open or correct as necessary.</li> <li>4. Check and correct as necessary.</li> <li>5. Check and correct as necessary.</li> </ol>
---	---	--

A. Freeze protection.

**NOTE: We cannot guarantee coils against freezing, but the likelihood of freezing can be minimized if the installer takes the following precautions.**

For steam or hot water systems:

1. Provide freeze protection controls.

For hot water systems:

1. Use constant water circulation.
2. Use glycol solution.

For steam systems:

1. Provide adequate sizing of condensate return lines, traps and vents to allow for steady flow of condensate from the coil.
2. Do not bush or reduce trapping size.
3. Do not drain steam mains or branch lines through coils. Steam lines should always be drained ahead of control valves.
4. When more than one coil is installed, a separate steam trap must be provided for each.

5. Steam traps should be sized for 3 times the calculated condensate loading at the coil design conditions, based on the pressure differential across the trap, **NOT** the boiler pressure. Traps should be of the type which pass condensate and air at saturated steam temperature. Inverted bucket traps should incorporate thermostatic air vents.
6. In low pressure steam systems (below 15 PSIG), where a non-venting trap is used for condensate removal, a thermostatic air trap should be installed in a 1" air line bypassing the condensate trap to the atmospheric return main. On systems with a vacuum return system, an automatic air vent should be installed in a 1" air line before the condensate trap.
7. Strainers should be installed ahead of traps to prevent dirt and sludge from affecting operation.
8. Proper vacuum breakers should be provided.
9. If condensate must be lifted above coil return level into overhead mains, or if return mains are pressurized, a pump and receiver should be installed between condensate traps and return mains.

## SECTION VIII – MAINTENANCE SCHEDULE AND LUBRICATION REQUIREMENTS

Periodic Maintenance is essential to the efficient operation and extended service life of this equipment. Failure to provide maintenance as recommended may void the equipment warranty.

**For any Air Curtain with optional gas heating section; refer to furnace manufacturer’s IOM manual for specific instructions regarding maintenance schedule.**

### A. Maintenance Schedule

1. After 8 hours of operation
  - a. Check that blower belts are tight and sheaves are aligned. The blower belts should be checked every 30 days after the first 60 days of new belt run-in.
  - b. Check set screws and bolts on the blowers, bearings, coupling, and sheaves.

### CAUTION: Do not overtighten belts

2. Monthly
  - a. Check all valves, piping and connections for leaks.
  - b. Inspect filters. Clean or replace as necessary.
  - c. Inspect the main fan bearings.
  - d. Ensure that there are no obstructions blocking the air supply or the air discharge from the Air Curtain.
  - e. Inspect the area and make sure that no combustible or hazardous material has been stored near the Air Curtain.
3. Quarterly
  - a. Complete the monthly maintenance schedule.
  - b. Check the belt tension for the main blowers and adjust if necessary.
  - c. Check the alignment of the sheaves and adjust if necessary.
  - d. Inspect all bearings, coupling, and set screws for tightness and lubricate bearings if necessary.
  - e. Check voltages and amp draw on main fan motor.
  - f. Check the operation of all safety controls individually.
4. Off Season or Yearly
  - a. Complete the monthly and quarterly maintenance schedule.
  - b. Inspect all blower wheels and housings. Clean if necessary.

- c. Check that all blower wheels, sheaves, and couplings are securely set on the shaft.
- d. Inspect all bearings and alignment. Adjust if necessary.
- e. Inspect all V-belts, sheaves, and coupling inserts. Replace if necessary.
- f. Inspect all electrical components, connections and terminals. Clean and tighten where necessary.
- g. Ensure all vents to the atmosphere are clean and free from obstruction.
- h. Lubricate the blower motor as directed by motor manufacturer.
- i. Inspect blower motor wiring for loose connections.
- j. Lightly oil all door latches.

**NOTE: Keep screened air intakes clear of obstructions at all times.**

### B. Lubrication Instructions

Item	Manufacturer	Bearing Type
All 3 phase blower motors ODP, TEFC	U.S., Baldor or equal	Single row ball bearings

Recommendation: see following note

All 1 phase (Fractional HP) ODP, TEFC	Century, G.E. motors or equal	Bronze sleeve bearings
---------------------------------------	-------------------------------	------------------------

Recommendation: see following note

Fan shaft bearings	Fafnir or equal	Self-aligning single row or double row ball bearings, resilient mounted
--------------------	-----------------	---

Recommendation: see following note

1. Blower Motors – Some motors require lubrication while others do not. Those that require lubrication can be identified by the presence of grease plugs in the motor casing at each end. Motors that do not have grease plugs cannot be greased and are lubricated for the life of the motor bearing.

Lubrication of motors should be done while the motor is warm and at a standstill. Remove and clean all grease plugs and insert a grease fitting in the upper hole in the motor casing at each end. (Viewed as if motor were sitting horizontally on its base). There may be one or two plugs in each end casing of the motor. Add a small amount of a clean, good grade ball bearing grease, such as Exxon Polyrex EM or equal, with a low pressure grease gun. Run the motor five minutes before removing the grease fittings and replacing the plugs.

**CAUTION: An excess of grease will overheat the bearings.**

**NOTE: On totally enclosed fan cooled (TEFC) motors, the rear end fan housings must be removed to expose the grease plugs.**

2. Pillow Block Bearings – Pillow block bearings are used on supply blowers. Bearings have been prelubricated with a number 2 lithium base grease. Relubrication should be done with a similar grease using a low pressure grease gun. Wipe all grease fittings clean before adding grease. Grease should be added slowly, in small amounts at frequent intervals while the shaft is being manually rotated.

A slight showing of grease at the seals with accompanying normal bearing temperature indicates proper lubrication. Normal temperature can range from “cool” to “hot to the touch” depending on size, speed and surrounding conditions. Excessive bearing temperature indicates faulty lubrication. An insufficient amount of grease is suggested by a bearing showing no grease at the seals, and a higher than normal temperature and noise level. Excessive leakage of grease at the seals, and a high operating temperature suggest too much grease.

3. Frequency of Lubrication – Frequency of lubrication depends upon operating conditions. The bearing operating temperature is the best index for determining a relubrication schedule. The following chart gives the frequency of relubrication based upon continuous operation for various operating temperatures and can be used as a satisfactory guide to determine when ball and roller bearings should be relubricated.

Speed	Temperature	Cleanliness	Interval
100 RPM	Up to 125° F	Clean	6 months
500 RPM	Up to 150° F	Clean	2 months
1000 RPM	Up to 210° F	Clean	2 weeks
1500 RPM	Over 150° F	Clean	Weekly
Any Speed	Up to 150° F	Dirty	1 week to 1 month
Any Speed	Over 150° F	Dirty	Daily to 1 week
Any Speed	Any Temp.	Very Dirty	Daily to 1 week
Any Speed	Any Temp.	Extreme Conditions	Daily to 1 week

### C. Air Filters

All filter banks should be equipped with a manometer or differential pressure switch to indicate when the filters are dirty. Filters should be replaced when the differential pressure across them reaches the manufacturer’s recommended final value. Dirty filter elements should be replaced with a clean element of the same type and size. In addition, **the manufacturer not only suggests, but insists, that air filters be checked every 30 days** and replaced with new filters as required.

The frequency of replacing air filters applies twelve months of the year, **where air Curtain is used year round.**

### D. Belt Tension and Adjustment

Belt tension is adjusted during the initial run-in and test periods at the factory. However, they are run as slack as possible to prevent excessive damage to the bearings, yet tight enough to prevent slippage.

It is necessary, therefore, to tighten all belts during the first few months of operation, and to **check for proper tension weekly during the first 60 days**, after which, 30-day check intervals are sufficient.

**NOTE: Turn off all power to the equipment before checking belt tension.**

**CAUTION: Do not attempt to tighten any belt or belts by changing the pitch of an adjustable pulley, as this will change the speed of a driven pulley, causing the unit to be rendered out of air balance.**

1. Suggested Belt Tension Method
  - a. Check tension frequently during the first 24-48 hours of run-in operation. Ideal tension is the lowest tension at which the belt will not slip under peak load conditions. Over tensioning shortens belt and bearing life.
  - b. To properly tension a conventional V-Belt drive, use the following procedure:
    - i. Measure the span length.
    - ii. At the center of the span, apply a force perpendicular to the span to deflect the belt 1/64 inch for every inch of span length. For example, for a 40 inch span, apply a force that will deflect the belt 40/64 or 5/8 of an inch.
    - iii. Compare the force you have applied with the values given in the table below. If the force is between the values for normal tension and 1-1/2 times normal tension, the belt tension should be satisfactory. If the belt tension is not within this range, it can be adjusted by loosening the motor mounting bolts and adjusting the position of the motor.

**NOTE: A new drive can be tightened to two times the minimum value shown to allow for normal drop in tension during the run-in period.**

<b>B Section small pulley diameter range in inches</b>	<b>Belt Manufacturer &amp; Type Belt</b>	<b>Pounds Force for Normal Tension</b>	<b>Pounds Force for 1 1/2 times Normal Tension</b>
3.4	Goodyear	4.9	7.4
	Goodyear Torque-Flex	7.1	10.7
4.4 - 4.6	Gates Hi-Power	4.4	6.6
	Goodyear HY-T	6.5	9.8
5.8 - 8.6	Goodyear	8.2	12.3
	Goodyear Torque-Flex	9.6	14.4
	Gates Hi-Power	5.8	8.7

Note: For recommendation of other types of belts, consult respective manufacturers.

#### **E. Optional Heating Coils**

Heating Coils – Coil surfaces must be kept clean of dirt and lint in order to operate at rated efficiency. Coils should be inspected on a regular basis and cleaned as required.

**CAUTION: Solutions used to clean coils must not be corrosive to metals or materials used in the manufacture of this equipment. If cleaning solutions are applied through means of high pressure spray, care must be taken to avoid damaging the coil fins.**

#### **F. Gaskets**

Gaskets are used on doors, inspection covers, and some filter racks. Inspect gaskets periodically and repair or replace as required.

## SECTION IX – REPLACEMENT PARTS

Replacement parts may be ordered from the factory. All warranty parts will be shipped freight allowed from factory with normal ground service. Warranty parts must be returned prepaid within **30 days**. Credit will be issued if part is complete, defective and returned on time.

When parts are ordered, MODEL NUMBER, SERIAL NUMBER, FACTORY ORDER (F.O.) and PART NUMBERS are required. Belts, filters, and fuses are not covered under warranty.

## SECTION X – AIR CURTAIN START-UP FORM

Serial No. \_\_\_\_\_ Model \_\_\_\_\_ Date \_\_\_\_\_  
 Job Name \_\_\_\_\_  
 Address \_\_\_\_\_  
 Representative \_\_\_\_\_ Contractor \_\_\_\_\_

A Start-Up report should be submitted for each unit on the job. Basic Factory Warranty is 12 months from date of shipment without Start-Up report on file at the factory. With a Start-Up report, Warranty is 12 months from start-up, not to exceed 18 months from date of shipment. In the event that controls are furnished by someone other than Factory, the controls supplier must be represented on the job at the time of start-up.

### GENERAL

- |   |   |
|---|---|
| 1. Inspect the unit exterior and interior for shipping and installation damage <input type="checkbox"/><br>2. Check bill of lading against material received <input type="checkbox"/><br>3. Make certain all packing material has been removed from unit <input type="checkbox"/><br>4. Check all fans for free movement <input type="checkbox"/><br>5. Tighten all electrical terminals <input type="checkbox"/> | 6. Tighten set screws on all pulleys, bearings and fans <input type="checkbox"/><br>7. Make certain all filters are installed <input type="checkbox"/><br>8. Check all controls for proper setting <input type="checkbox"/><br>9. If applicable, check nite set-back and time clock for operation <input type="checkbox"/><br>10. Check belts for proper tension and alignment <input type="checkbox"/> |
|---|---|

### MOTORS

Make sure heating controls are not activated

- |  |  |
|--|--|
| 1. Check rotation of all motors <input type="checkbox"/><br>2. Check fan R.P.M. _____<br>Check fan R.P.M. _____<br>3. Check voltage L1 _____ L2 _____ L3 _____ | 4. Check control voltage _____<br>5. Check amp draw (refer to nameplate)<br>Fan Motor #1 L1 _____ L2 _____ L3 _____<br>Fan Motor #2 L1 _____ L2 _____ L3 _____ |
|--|--|

### STEAM or HOT WATER HEATING SECTION

(If Applicable)

1. Inspect condition of coil

REMARKS: \_\_\_\_\_  
 \_\_\_\_\_  
 \_\_\_\_\_

### GAS HEATING SECTION

(If Applicable)

- |  |   |
|--|---|
| 1. Heater Model No. _____<br>2. Inlet gas pressure _____ in. W.C.<br>3. Check pilot and main burner ignition <input type="checkbox"/><br>4. Check manifold gas pressure _____ in. W.C.<br>5. Cycle heater(s) on high limit <input type="checkbox"/><br>6. Cycle firestat or freezestat (iff applicable) <input type="checkbox"/> | 7. Cycle and check out all other control <input type="checkbox"/><br>8. Check operation of remote panel <input type="checkbox"/><br>9. Check entering air temperature _____ F°<br>10. Check discharge air temperature (high fire) _____ F°<br>11. Cycle by thermostat or operating control <input type="checkbox"/> |
|--|---|

This unit has been checked and started in accordance with the above procedures and is operating satisfactorily.

**Copy and Return To:**  
**4830 Transport Drive, Dallas, TX 75247**  
**Phone: (214) 638-6010 Fax: (214) 905-0806**  
**Attention: Technical Services Department**

Contractor (Purchaser) \_\_\_\_\_  
 Representative \_\_\_\_\_  
 Start-Up Operator \_\_\_\_\_  
 Phone No. \_\_\_\_\_