

INSTALLATION INSTRUCTIONS FOR AIR CONTROL DAMPERS

GENERAL

Upon receipt of the damper(s) at the site, inspect all items; note on Bill of Lading. Unpack all dampers carefully. Immediately note any damage and inform your representative. Do not install; it is easier to repair a damper on the floor than up in the duct.

Do not stack dampers on each other or allow debris to fall on them. Avoid rehandling if possible; install each unit as soon as possible after unpacking.

DAMPER INSTALLATION

Prior to installing the damper, inspect the ductwork and surrounding area for any obstructions that might interfere with the linkage, blade rotation or actuator mounting. Care must be taken not to drop, drag, crush, or apply excessive bending, twisting, racking or skewing loads upon the damper frame, blades, linkage or accessories (see fig. 1 on reverse side). Never use a chain or hook inside the damper frame for lifting, as this could damage blades, seals or frame.

- A. We recommend lubricating moving parts with dry graphite.
- B. Manual dampers should be run through a full-open to full-close cycle by hand to insure proper operation of the damper.
- C. Motorized dampers should be checked by a preliminary attempt to operate with the motor. If binding occurs, disconnect one end of the driving linkage (and note its exact position beforehand) to operate damper manually and check per above. Reconnect linkage and check again.
- D. If an externally mounted operator is being utilized, a 1" diameter hole must be drilled in the duct to accommodate the operator (see fig. 5 on reverse side). Locate drive blade axle. Measure from bottom of damper to center of drive blade axle. Transfer this to wall of duct and drill 1" diameter hole.
- E. Lift panels into duct (or opening) by its frame, not by any blade or hardware. Final position must be square, straight, plumb, and without twist (See fig. 1 on reverse side).
- F. Due to shipping and handling, dampers may arrive at the site slightly racked or twisted. Dampers are to be squared and not twisted prior to installation into square duct or sleeves.
- G. See fig. 2 on reverse side for attachment methods.
- H. Damper should be shimmed in the opening to prevent distortion of the frame by the fasteners holding it in place. Dampers with seals should be caulked to prevent leakage between the frame and duct.
- I. Check the damper for free operation.

MULTIPLE-PANEL DAMPERS

Multiple-panel dampers will be tagged for ease of assembly (see fig. 3 & 4 on reverse side or drawing C24278).

OPERATORS

- A. An extended shaft kit (see fig. 5 on reverse side) is supplied if no operator is specified.
- B. Reference specific installation instructions supplied with damper operator for motorized dampers.
- C. Multi-panel dampers with jackshifting: See separate instructions for installation of jackshifting when not factory installed.

MAINTENANCE

In general this unit must be kept clean and free from foreign matter that may impede normal movement and seating of blades and seals (if applicable). A cleaning schedule should be established and is entirely dependent upon the environment into which the damper is placed. The damper is basically maintenance free with the above exception and regular lubrication and seal inspection as indicated below:

BEARINGS AND LINKAGE PIVOTS: Lubricate with dry graphite as required to provide free movement.

FIGURE 1

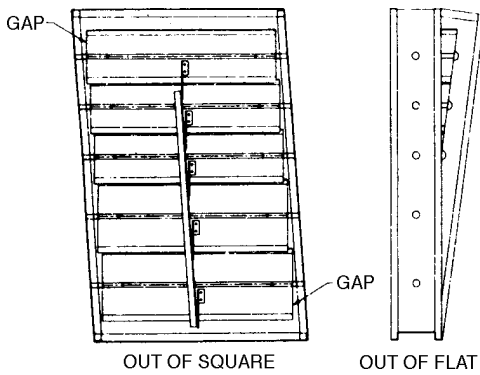

WARNING

Improperly installed dampers and damper panels prevent the blades from sealing properly. Gaps between the blades and frame indicate a damper that has been installed out of square. Gaps between the blades indicate a damper installed out of flat. Out of square installations can cause damage to side seals and will also require excessive actuator torque.

FIGURE 2

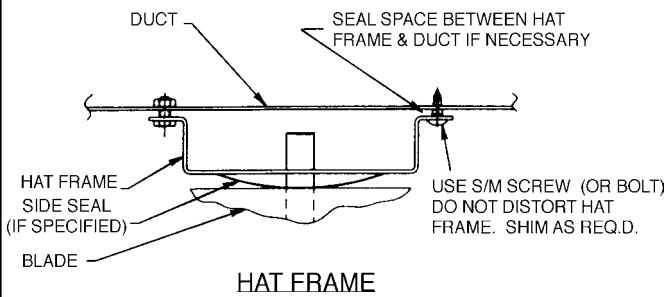
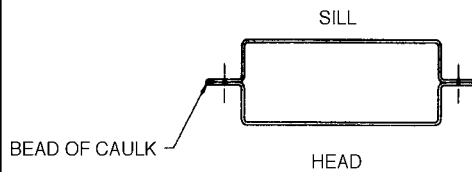
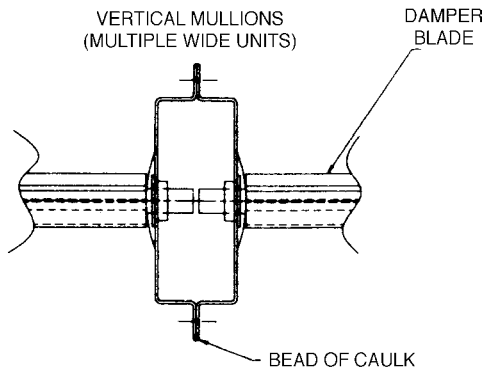

FIGURE 3

HORIZONTAL MULLIONS
(MULTIPLE HIGH UNITS)



VERTICAL MULLIONS
(MULTIPLE WIDE UNITS)



USING 1/4-20 BOLTS, WASHERS AND LOCKNUTS OR #10 SHEET METAL SCREWS, JOIN PANELS TOGETHER.

AWV

american warming
and ventilating

FIGURE 5

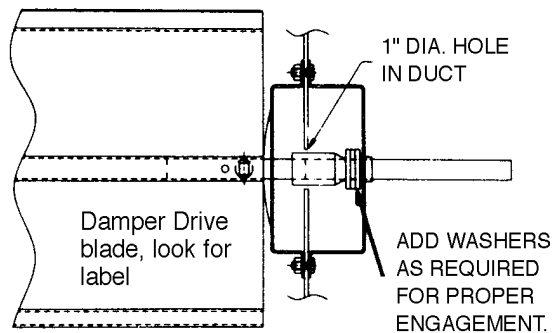
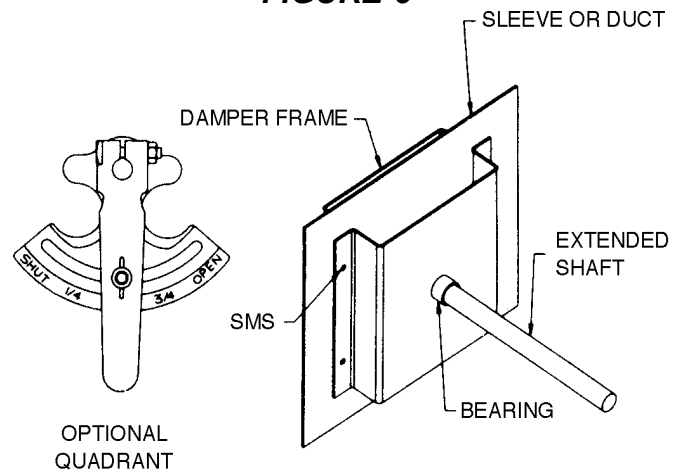

SECTION VIEW

**7301 International Dr.
Holland, OH 43528
Phone: 419-865-5000
Fax: 419-865-1375**